

GEOTECHNICAL EXPLORATION
MARINA COAST WATER DISTRICT
REGIONAL URBAN WATER AUGMENTATION
PROJECT – 100 PERCENT DESIGN
MARINA, CALIFORNIA

SUBMITTED
TO
RMC WATER AND ENVIRONMENT
SAN JOSE, CALIFORNIA

PREPARED
BY
ENGEO INCORPORATED
PROJECT NO. 7496.1.001.01
AUGUST 7, 2007

COPYRIGHT © 2007 BY ENGEO INCORPORATED. THIS DOCUMENT MAY NOT BE REPRODUCED IN WHOLE OR IN PART BY ANY MEANS WHATSOEVER, NOR MAY IT BE QUOTED OR EXCERPTED WITHOUT THE EXPRESS WRITTEN CONSENT OF ENGEO INCORPORATED.

Project No.
7496.1.001.01

August 7, 2007

Ms. Stephanie Hughes
RMC Water and Environment
2290 North First Street, Suite 212
San Jose, California 95131

Subject: Marina Coast Water District
Regional Urban Water Augmentation Project – 100 percent Design
Marina, California

GEOTECHNICAL EXPLORATION

Dear Ms. Hughes:

With your authorization, ENGEO Incorporated conducted a geotechnical exploration the proposed Regional Urban Water Augmentation Recycled Water Pipeline project in Marina, California. The accompanying report contains our exploration data, gathered existing data, and findings with recommendations for design. It is our opinion that the proposed development is feasible from a geotechnical standpoint, provided the recommendations included in this report are followed.

We are pleased to be of service to you on this project. If you have any questions regarding the contents of this report, please contact us.

Very truly yours,

ENGEO INCORPORATED

Douglas Wahl
dw/smc

R. William Rudolph, GE

cc: Mr. Brad Hamada, RMC Water and Environment

TABLE OF CONTENTS

Letter of Transmittal	<u>Page</u>
INTRODUCTION	1
Purpose and Scope.....	1
Site Location and Description.....	2
Proposed Development.....	2
Line E and Ardennes Laterals.....	4
GEOLOGIC CONDITIONS	5
Geologic Setting.....	5
Project Alignment Geology.....	5
Regional Seismicity.....	5
GEOTECHNICAL EXPLORATION	10
Existing Data Review.....	10
Interviews.....	10
Field Exploration.....	10
Laboratory Testing.....	12
Subsurface Soil Conditions.....	12
Test Pits.....	13
Groundwater.....	14
Pavement Coring.....	14
CONCLUSIONS AND DISCUSSION	16
Seismic Hazards.....	16
Ground Rupture.....	16
Ground Shaking.....	17
Liquefaction.....	17
Densification Due to Earthquake Shaking.....	18
Lurching and Lateral Spreading.....	18
Building Code Seismic Information.....	19
Trenching.....	19
Corrosion Potential.....	21
RECOMMENDATIONS	22
General.....	22
Structures.....	22
Grading.....	22
5th Avenue Pump Station Foundations.....	22
Surface Drainage.....	24
Retaining Walls and Basement Walls.....	24
Pipeline Design.....	25

TABLE OF CONTENTS (Continued)

Trench Excavation and Shoring.....27
Pavement Design Recommendations30
LIMITATIONS AND UNIFORMITY OF CONDITIONS31

SELECTED REFERENCES

FIGURES AND TABLE

APPENDIX A – Boring Logs

APPENDIX B – Laboratory Test Data (ENGEO Incorporated)

APPENDIX C – Existing Information

APPENDIX D – Preliminary Trenching Evaluation Letter

DRAFT

INTRODUCTION

Purpose and Scope

The purpose of this geotechnical exploration is to characterize subsurface conditions along the alignment of the proposed trunk pipeline, associated laterals, and at the pump station and water tank locations. The pipeline sections addressed in this report are indicated on Figures 1 and 2. The report also includes conclusions and recommendations regarding geotechnical aspects of pipeline construction including temporary slope stability, pipe bedding and backfill, existing pavement conditions, soil corrosion potential, and foundation design criteria for the proposed structures.

The scope of our work included a review of available literature and reports, as well as geologic maps for the immediate area, gathering existing geotechnical data, exploratory drilling and sampling as well as test pit excavation and observation, destructive pavement coring, laboratory testing of subsurface materials collected from the boreholes, analysis of the geotechnical data, and preparation of this report with recommendations for design and construction. This report addresses the following:

- Physical properties of the soils encountered along the subject pipeline alignment.
- Assessment of geological hazards on the subject pipeline alignment, structure sites, and in the general project area.
- Construction considerations, including trenching.
- Foundation design recommendations.
- Pavement design recommendations.

This report was prepared for the exclusive use of RMC Water and Environment and their design team consultants. In the event that any changes are made in the character, design, or layout of the development, the conclusions and recommendations contained in this report must be reviewed by ENGEO to determine whether modifications to the report are necessary. This document may not be reproduced in whole or in part by any means whatsoever, nor may it be quoted or excerpted without the express written consent of ENGEO Incorporated.

Site Location and Description

This report presents the results of the geotechnical exploration performed by ENGEO Incorporated for the Marina Coast Water District (MCWD) Regional Urban Water Augmentation Project located in the cities of Marina, Seaside, and the former Fort Ord military base. The overall project location is shown on the Vicinity Map, Figure 1. The project has two major components, a recycled water system and a proposed desalination plant. This report is limited to the recycled water distribution system portion of the project.

In order to augment existing urban water supply, the MCWD proposes to construct an urban recycled water distribution system consisting of trunk pipelines, pump stations, and operational storage to meet a demand of approximately 1500 acre-feet per year (AFY). The recycled water source will be the Monterey Regional Water Pollution Control Agency (MRWPCA) Regional Treatment Plant (RTP) located north of Marina. Effluent from the RTP receives tertiary treatment at the Salinas Valley Reclamation Plant (SVRP) where the pipeline is expected to originate.

Proposed Development

Ultimately, the project is expected to include about 121,000 linear feet of trunk and lateral pipelines, approximately 78,000 feet of which is assessed in this geotechnical report. Other

project features will include the 1.5-million-gallon Blackhorse Reservoir and the 5th Avenue Pump Station which are included in this report. The project will also include a 2-million-gallon earthen reservoir and pump station near the existing SVRP. The developments of the earthen reservoir and pump station at the SVRP are not within the scope of our services for this report. In addition a geotechnical investigation was previously conducted for the Blackhorse Reservoir by others and we understand that the previous report will be used as the basis of geotechnical design for that portion of the project (Kleinfelder 2005).

The Recycled Water Pipeline alignment, as shown on the attached Figure 2, Project Alignment, generally runs along existing roadways and MCWD rights-of-way. The trunk pipeline begins at the SVRP and continues along easements in the area known as “Armstrong Ranch” south toward the north terminus of Crescent Avenue. A lateral proceeds west along Beach Road out to Highway 1. The trunk proceeds south on Crescent Avenue to Carmel Avenue with a lateral going off to the west on Reservation Road.

The trunk then proceeds to Vaughn Avenue and goes south to Reindollar Avenue. A lateral extends from Vaughn on Carmel Avenue to the east. The trunk continues east on Reindollar, then turns south on California Avenue, continues on 5th Avenue into the California State University, Monterey Bay (CSUMB) campus and proceeds to 3rd Street. Laterals proceed from 5th Avenue west onto 9th Street and north on 2nd Avenue; however, these laterals are not within our scope. Another set of laterals proceeds east along Abrams Drive from California Avenue until Imjin Road and splits into two sections, one along Imjin to the north and one continuing along Abrams. Portions of the Abrams Drive lateral are within our scope; however, the Imjin Road lateral is not.

The trunk continues from 3rd Street east until it reconnects with 5th Avenue and heads south into unpaved areas of the campus. The trunk then connects with General Jim Moore Boulevard and proceeds south. Laterals extend east at Ardennes Circle heading up to Blackhorse Reservoir and

beyond, and west at Coe Avenue. The trunk pipeline is expected to be 16 to 20 inches in diameter and lateral pipelines are expected to vary from 12 to 4 inches in diameter. Typically the pipelines will have 4 foot minimum cover and trench depth will be approximately 6 to 7 feet below finish grades.

The only areas where the pipeline alignment appears to be located on undeveloped land are in “Armstrong Ranch”, at the north end of the alignment by the SVRP pump station, on CSUMB property between 5th Avenue and General Jim Moore Boulevard, and near Blackhorse Reservoir. At the north end of the alignment, near the SVRP, the ground surface elevations are around 100 feet (msl datum). As the alignment progresses to the south, surface elevations slope downward to a minimum elevation of around 15 feet near the intersection of Beach Road and Highway 1. The elevation rises again as the alignment progresses to the south through the former Fort Ord military base. The highest elevation (about 485 feet) is near the Blackhorse reservoir, located east of the General Jim Moore Boulevard main trunk alignment. The main alignment then descends and is at about elevation 100 feet at the south end of General Jim Moore Boulevard.

Line E and Ardennes Laterals

Subsequent to our completion of the initial phase of work for this project, we were asked to evaluate two additional laterals named the Line E and Ardennes laterals respectively. The Line E lateral originates on West Blanco Road on the eastern side of a research park in north Marina, proceeds south along West Blanco to Reservation Road, turns east and proceeds along Reservation until terminating at the intersection of Reservation Road and Inter-Garrison Road.

The Ardennes Lateral originates near the intersection of Normandy Road and General Jim Moore Boulevard, proceeds east off road behind an existing elementary school, turns southeast going up a hill along a paved walking path, and ends at the Blackhorse Reservoir at the top of the hill.

GEOLOGIC CONDITIONS

Geologic Setting

The regional geology for the project was characterized in a report by Geomatrix Consultants, Inc. titled, “*Feasibility-Level Geologic and Geotechnical Study Carmel River Plan B*,” dated April 2001. According to this report, the geology of the area is characterized by Quaternary beach, alluvial, and dune deposits overlying Tertiary sedimentary rocks and Mesozoic granitic rocks. The Mesozoic granitic rocks are part of the Salinian Block, an elongate, northwest-southeast trending tectonic sliver bounded on the northeast by the San Andreas Fault and on the southwest by the San Gregorio Fault. These basement rocks, along with Paleozoic metamorphic rocks, form the core of the local Santa Cruz Mountains. The overlying Tertiary sequence is locally more than 10,000 meters thick (Clark, 1981). This characterization is consistent with our review of regional geologic maps.

Project Alignment Geology

Review of existing geologic maps shows that the entire proposed alignment is underlain by Older Stabilized Dune Deposits as depicted in Figure 3 (Wagner 2002) consisting of clean to silty sands, which are loose to medium dense in the upper 10 feet or so. The sands have varying moisture content, depending on the surfacing, local hydrology, and the time of year.

Regional Seismicity

The entire project area lies within a region of active faulting and high seismicity associated with the San Andreas Fault system. The San Andreas Fault system comprises a zone of major, northwest-trending active strike-slip faults that includes from east to west, the Calaveras, Hayward, San Andreas, and San Gregorio-Hosgri faults (Figure 4). The San Andreas Fault

system has been the source of numerous moderate- to large-magnitude historical earthquakes that caused strong ground shaking in the project area, including the 1906 San Francisco earthquake and the 1989 Loma Prieta earthquake. Future strong ground shaking from nearby large magnitude earthquakes is a certainty and should be a consideration in the design of the new project facilities and components.

At its closest point relative to the project area (Salinas Valley Reclamation Plant), the San Andreas Fault lies approximately 17 miles to the northeast; however, several other active and potentially active faults occur within the project limits. These include the potentially active King City, Chupines, Navy, and Tularcitos faults, and the active Monterey Bay fault zone. The Monterey Bay fault zone lies offshore along the northwest projection of the Navy Tularcitos and Chupines faults, and is considered active based on offset seafloor sediments of Holocene age (Jennings, 1994). The Navy-Tularcitos and Chupines faults are considered potentially active by the California Division of Mines and Geology, based on documented Pleistocene displacements along all or part of their mapped lengths (Jennings, 1994); however, Rosenberg and Clark (1994) have identified possible evidence of Holocene displacement on the Navy-Tularcitos and Chupines faults. Other nearby active faults include the Palo Colorado fault (part of the San Gregorio - Hosgri fault zone) and the Cypress Point fault, both of which lie about 3 miles from the project area.

Three site locations were chosen to determine distances from active faults in the area. These include the Blackhorse Reservoir, the SVRP Pump Station, and the proposed location for the 5th Avenue Pump Station. The distance from each site location to active faults within 100 kilometers (km) and estimated maximum Moment magnitude^{1,2} events are summarized in Tables 1 through 3.

¹ Moment magnitude is an energy-based scale and provides a physically meaningful measure of the size of a faulting event. Moment magnitude is directly related to average slip and fault rupture area.

Table 1
Regional Faults and Seismicity – Blackhorse Reservoir

Fault Name	Distance (km)	Direction from Site	Maximum Moment Magnitude
Rinconada	5.6	Northeast	7.3
Monterey Bay - Tularcitos	8.1	Southwest	7.1
San Gregorio South	20.3	West	7.1
Zayante-Vergeles	25.9	Northeast	6.8
San Andreas - 1906 Rupture	32.9	Northeast	7.9
San Andreas - Santa Cruz Mnts.	32.9	Northeast	7.2
San Gregorio North	36.6	Northwest	7.3
Sargent	39.8	Northeast	6.8
Southern Calaveras	41.2	Northeast	6.1
Central Calaveras	49.0	Northeast	6.6
Quien Sabe	50.0	Northeast	6.4
Hosgri	54.0	South	7.3
Monte Vista	61.2	North	6.8
San Andreas - Peninsula	63.4	North	7.2
Hayward - South East Extension	71.8	North	6.4
Ortivalita	75.1	Northeast	6.9
Great Valley - 8	78.4	Northeast	6.6
Great Valley - 9	78.8	Northeast	6.6
Great Valley - 10	84.7	East	6.4
Hayward - Total	90.4	North	7.1

² California Division of Mines and Geology, 1996, *Probabilistic Seismic Hazard Assessment for the State of California*, CDMG Open-File Report 96-08.

Table 2
Regional Faults and Seismicity – SVRP Pump Station

Fault Name	Distance (km)	Direction from Site	Maximum Moment Magnitude
Rinconada	3.4	South	7.3
Monterey Bay - Tularcitos	13.6	Southwest	7.1
Zayante-Vergeles	18.7	Northeast	6.8
San Gregorio South	25.3	West	7.1
San Andreas - 1906 Rupture	25.4	Northeast	7.9
San Andreas - Santa Cruz Mnts.	25.5	Northeast	7.2
Sargent	32.2	Northeast	6.8
San Gregorio North	34.7	West	7.3
Southern Calaveras	35.5	Northeast	6.1
Central Calaveras	41.2	Northeast	6.6
Quien Sabe	43.6	Northeast	6.4
Monte Vista	53.3	North	6.8
San Andreas - Peninsula	56.4	North	7.2
Hosgri	61.9	South	7.3
Hayward - South East Extension	63.6	North	6.4
Ortitalita	69.3	Northeast	6.9
Great Valley - 8	72.0	Northeast	6.6
Great Valley - 9	72.7	Northeast	6.6
Great Valley - 10	81.7	East	6.4
Hayward - Total	82.4	North	7.1

Table 3
Regional Faults and Seismicity –5th Avenue Pump Station

Fault Name	Distance (km)	Direction from Site	Maximum Moment Magnitude
Rinconada	4.7	East	7.3
Monterey Bay - Tularcitos	8.4	Southwest	7.1
San Gregorio South	20.4	West	7.1
Zayante-Vergeles	24.5	Northeast	6.8
San Andreas - 1906 Rupture	31.4	Northeast	7.9
San Andreas - Santa Cruz Mnts.	31.4	Northeast	7.2
San Gregorio North	34.0	Northwest	7.3
Sargent	38.2	Northeast	6.8
Southern Calaveras	40.6	Northeast	6.1
Central Calaveras	47.2	Northeast	6.6
Quien Sabe	49.2	Northeast	6.4
Hosgri	57.1	South	7.3
Monte Vista	58.1	North	6.8
San Andreas - Peninsula	60.2	North	7.2
Hayward - South East Extension	69.0	North	6.4
Ortivalita	74.6	Northeast	6.9
Great Valley - 8	77.5	Northeast	6.6
Great Valley - 9	78.1	Northeast	6.6
Great Valley - 10	85.4	East	6.4
Hayward - Total	87.4	North	7.1

GEOTECHNICAL EXPLORATION

Existing Data Review

As part of our investigation, we reviewed the results of previous geotechnical investigations conducted by others at or in the vicinity of the project. A list of the reports we reviewed is presented in Appendix C.

Interviews

Our staff conducted several interviews with people familiar with the area to gather information regarding trenching conditions in the area. These interviews were conducted with representatives of local and regional contractors, local agencies, and people with experience relevant to the project. We issued a preliminary trenching evaluation letter dated October 23, 2006 (ENGEO 2006), containing opinions expressed by others regarding trenching conditions in the area, as well as our own preliminary recommendations regarding trench construction and design for the project. A copy of this letter is included in Appendix D.

Field Exploration

The first sequence of field exploration for this study was conducted in October 2006, and consisted of drilling 20 exploratory boreholes to typical depths of approximately 13.5 to 16.5 feet below the existing ground surface, at the approximate locations shown on Figure 5. Two exceptions were the boring at the intersection of Crescent Avenue and Reservation Road which was drilled to a depth of 31.5 feet, and the boring at the 5th Avenue Pump Station which was drilled to a depth of 26.5 feet. The borings were approximately located by pacing from existing features, and topographic elevations were taken from the tentative plans dated October 20, 2006, provided by Carollo Engineers at the time of our study. The locations were selected based on an

approximate spacing of 2,000 feet between borings and the useful existing information previously collected.

Exploratory test borings were drilled using a truck-mounted, drill rig equipped with 4-inch-diameter solid flight augers. An ENGEO engineer logged the boreholes in the field and collected soil samples using either a 3-inch O.D. California-type split-spoon sampler fitted with 6-inch-long brass liners or a 2-inch O.D. Standard Penetration Test (SPT) split-spoon sampler.

The standard penetration test (SPT) requires a 2-inch-diameter split-spoon sampler advanced by a 140-pound hammer with a 30-inch drop. The penetration of the 2-inch-diameter sampler into the native materials is field recorded as the number of blows needed to drive the sampler 18 inches in 6-inch increments. SPT results on the boring logs are recorded as the number of blows required for the last one foot of penetration. Where the California-type split-spoon sampler was used, the hammer weight and drop were the same as for the SPT and penetration into native materials is recorded in the same manner as for the SPT. No correction factors have been applied to the number of blows; thus, the blow-counts given on the borelogs represent “raw data” for either the SPT or the California-type sampler.

The field logs were used to develop the report borelogs (Appendix A). The logs depict subsurface conditions within the borings for the date of drilling; however, subsurface conditions may vary with time. The boreholes were backfilled with site soil up to the ground surface on the day of the field exploration and patched with cold-mix asphalt concrete or cement grout at the surface as appropriate to match the existing surface treatment. Cold-mix asphalt concrete was later replaced with hot-mix asphalt at a convenient time.

The second sequence of field exploration for this study was conducted on March 6, 2007, and consisted of excavating two test pits. The exploratory test pits were excavated using a backhoe excavator and an ENGEO Engineer logged the test pits in the field in accordance with the

Unified Soil Classification System. The test pits were loosely backfilled during our exploration. The locations of the exploratory test pits are shown on Figure 5.

The boring and test pit logs present specific soil and groundwater conditions at each exploration location and we include the logs in Appendix A. The logs contain the soil/rock type, color, consistency, and visual classification in general accordance with the Unified Soil Classification System.

Laboratory Testing

Representative samples of on-site soils were selected for laboratory testing to determine the following soil characteristics:

Soil Characteristic	Test Method	Report Location
Natural Unit Weights	ASTM D-2216	Table 4 and Appendix A
Moisture Contents	ASTM D-2216	Table 4 and Appendix A
Percent Fines	ASTM D-422	Table 4 and Appendix B

Laboratory data results are presented on the borelogs (Appendix A) with individual laboratory test results shown in Appendix B.

Subsurface Soil Conditions

Subsurface soil conditions are depicted on the borelogs. In general, the subsurface soils encountered were clean to silty sands, with varying moisture from dry to moist and wet in areas where the water table was encountered. Some borings along the alignment encountered a layer of silty sand with fines content on the order of 10 percent directly beneath the pavement section or graded dirt road. This layer extended to depths varying from 4 to 7 feet below grade. This

upper silty layer was found in Borings B-1, B-8, and B-19; however, it does not appear to be consistent along the alignment.

The section of the alignment that runs beneath graded dirt roads on CSUMB property, where Borings B-5 and B-6 were drilled, has a layer of this silty sand with fines content on the order of 10 percent; however, this soil is extremely dry and caused difficulty in drilling because the hole would tend to collapse.

The soils, in general, appear to vary in fines content from approximately 1 percent up to 15 percent passing the No. 200 sieve, but a consistent geospatial pattern is not present. The soils encountered were sands and silty sands or sands with silt to the extent of the depths explored. No clays or clayey sands were encountered. References by others to “more clayey spots” may in fact be referring to areas where silty sands or higher fines content may be present in the upper soil profile.

Test Pits

Two test pits which we excavated on March 6, 2007. Test pit 2-TP1 was initially about 8 feet deep and 4 feet wide with vertical side walls. Approximately 10 minutes after excavation the pit caved to approximately 8 feet wide at the surface and the walls regressed at an angle of approximately 1:1 (horizontal:vertical) before backfilling.

Test pit 2-TP2 was dug to approximately the same initial dimensions as 1-TP1 (4 feet wide, by 8 feet deep) and did not experience significant caving. The sides were left vertical for approximately 30 minutes until backfilling.

Groundwater

Groundwater was not encountered in any borings to the depths explored. Previous field exploration done by LandMarine Geotechnics showed shallow groundwater at approximately 10 feet below the ground surface near the intersection of Reservation Road and Beach Road. This area shows evidence of shallow groundwater and surface water with relatively low surface elevations of approximately 15 to 25 feet above mean sea level. Groundwater throughout the rest of the project alignment according to a hydrologic study of the region (MCWD 2005) is expected to lie well below the proposed trenching excavations, in most cases by 100 feet or more.

The groundwater regionally is characterized as belonging to two aquifers, the 180-Foot Aquifer and the 400-Foot Aquifer with the names referring to the depths where groundwater can be encountered. Both are protected from contamination by clayey aquitards. Locally perched conditions could occur throughout the project alignment and vicinity, however, due to the high hydraulic conductivity of the encountered soils, perched conditions should not persist over a reasonable amount of time (i.e. hours).

Fluctuations in groundwater levels may occur seasonally and over a period of years because of precipitation, perched aquifer zones, changes in drainage patterns, and other various factors. In addition, future irrigation could cause an overall rise in the local groundwater levels and future pumping could result in regional subsidence.

Pavement Coring

In addition to our exploratory borings, we also utilized destructive pavement coring in order to characterize the thicknesses of pavements throughout the project limits. Pavement cores were drilled at 33 locations along the proposed pipeline alignment (Figure 6). The coring process consisted of drilling through the asphalt concrete and through the underlying aggregate base

section to the top of subgrade. The cores did not penetrate beyond the bottom of the pavement section in any case (where the pavement section includes the pavement material and the sub-base).

No samples were retained and the holes were temporarily patched with cold-mix asphalt. Hot-mix asphalt was later used to replace the temporary patches. All cores were taken as close to the shoulder as possible without compromising the integrity of the sampling. The layer thicknesses of both the surface treatment and the base section were recorded.

In general, the newer pavements were more consistent in section thickness and quality, with older pavements, particularly those found within the former Fort Ord, generally being of lower quality and varying thickness. The thickest section was found near the intersection of Crescent Avenue and Reservation Road with up to 9 inches of asphalt and 3 inches of aggregate base. The thinnest section was found on California Avenue just south of Imjin Avenue where 5 inches of asphalt was found with no aggregate base. Typical thicknesses were 3 to 4 inches of asphalt over 4 to 6 inches of aggregate base. Figure 7 presents the results of our pavement coring survey.

CONCLUSIONS AND DISCUSSION

Based on our review of existing geotechnical information, the findings of the subsurface exploration, laboratory test results, and engineering analyses, we conclude that the proposed pipeline and associated structures are feasible from a geotechnical standpoint. The primary geotechnical concerns for the proposed project are caving sands throughout the pipeline alignment and cyclic densification of loose sands beneath structures and the pipeline. In addition, liquefaction is possible near the intersection of Reservation Road and Beach Road due to the shallow groundwater table in this vicinity. Recommendations for mitigation of these concerns are discussed in the Recommendations section of this report. We also discuss conclusions regarding trenching conditions and corrosion in this section.

Seismic Hazards

Potential seismic hazards resulting from a nearby moderate to major earthquake can generally be classified as primary and secondary. The primary effect is ground rupture, also called surface faulting. Secondary seismic hazards include ground shaking, lurch cracking, soil liquefaction, lateral spreading, landslides, tsunamis and seiches. These hazards are discussed in the following sections.

Based on topographic and lithologic information, the risks of regional subsidence or uplift, landslides, lateral spreading, tsunamis or seiches are considered low for the project.

Ground Rupture

The site is not located within a State of California Earthquake Fault Zone for active faults and no known active faults are shown on regional geologic maps covering the site. It is our opinion that the ground rupture hazard for the project is low.

Ground Shaking

The hazard of ground shaking can best be mitigated with quality construction. Seismic design provisions in current building codes generally prescribe minimum lateral forces, applied statically to the structure, combined with the gravity forces of dead and live loads. The code-prescribed lateral forces are generally considered to be substantially smaller than the peak forces that are associated with a major earthquake. Therefore, structures should be designed to: (1) resist minor earthquakes without damage, (2) resist moderate earthquakes without structural damage, but with some nonstructural damage, and (3) resist major earthquakes without collapse, but with some structural as well as nonstructural damage.

Liquefaction

Liquefaction is a phenomenon in which saturated cohesionless soils are subject to a temporary loss of shear strength because of pore pressure build-up under the cyclic shear stresses associated with earthquakes.

Geomatrix Consultants, as part of their report titled *Feasibility-Level Geologic and Geotechnical Study Carmel River Plan B*, evaluated liquefaction risk in the project area. The results of their assessment were reported in the Preliminary Geotechnical Report completed by LandMarine Geotechnics. Most of the project area was classified as having low liquefaction hazard. This is primarily due to the fact that the groundwater level is deep and the potentially susceptible loose sands are limited to the upper 10 to 20 feet; however, there is a portion of the proposed alignment near the intersection of Reservation and Beach Roads where liquefaction potential is characterized as moderate. This is due in large part to the lower elevation and, hence, shallower groundwater in the vicinity. The only area within the project limits where a shallow groundwater table was encountered is in the vicinity of the intersection of Reservation and Beach Roads. The rest of the alignment and structure sites are not susceptible to liquefaction due to the

absence of saturated conditions; however, dry, loose, sand can densify in strong seismic shaking. This type of hazard is discussed in a separate section.

Based on the findings of our exploratory borings and CPTs in the vicinity of Reservation and Beach Roads, combined with laboratory test results on soils recovered from this area, the subsurface soils in this area appear to be susceptible to liquefaction. The potential ground surface settlement due to liquefaction in this vicinity is on the order of 1 inch. Differential movement could be on the order of 0.5 inch in 50 feet.

In summary, the liquefaction hazard along most of the alignment is low. There is a moderate hazard potential near the intersection of Reservation Road and Beach Road. Liquefaction in this area could potentially result in differential movement of the pipeline during a major seismic event.

Densification Due to Earthquake Shaking

Densification of the sandy soils both above and below the groundwater level can cause settlement during an earthquake. The sands encountered along the pipeline alignment and at the sites of the proposed pump station and reservoir range from loose to very dense. We estimate that in general, very strong earthquake shaking will cause up to 1 inch of settlement of the ground surface for the majority of the pipeline. Ground settlement in a large seismic event at the proposed 5th Avenue Pump Station is expected to be on the order of ¾ inch with differential movement on the order of 0.5 inch in 50 feet.

Lurching and Lateral Spreading

Movement of weaker soils on slopes or adjacent to open channels or slopes during strong ground shaking is referred to as lurching, which is often accompanied by the development of ground cracking. Lurching typically occurs in more clayey soils and not in sands due to the tendency of

sands to slough down the affected slope rather than slide or move in a cohesive block. Based on the encountered soils, lurching is unlikely along the project alignment.

Lateral spreading refers to the movement of surficial soils downslope or toward an open face over the top of liquefied zones beneath. This movement is driven by gravity and the sudden loss of strength of the underlying materials causing blocks or masses of soil to displace. Based on the current proposed development concept, we do not anticipate open channels, significant slopes, or open faces within the project limits. On that basis, lateral spreading is unlikely at this site.

Building Code Seismic Information

Based on the subsurface soil conditions encountered and local seismic sources, the 5th Avenue Pump Station may be designed based on Chapter 16 of the 1997 UBC using the following information.

UBC Seismic Factors

Categorization/Coefficient	Design Value
Soil Profile Type (Table 16-J)	S_D
Seismic Zone (Figure 16A-2)	4
Seismic Zone Factor (Table 16-I)	0.4
Seismic Source Type (Table 16-U)	A
Near Source Factor N_a (Table 16-S)	1.6
Near Source Factor N_v (Table 16-T)	1.2
Seismic Coefficient C_a (Table 16-Q)	$0.44 N_a$
Seismic Coefficient C_v (Table 16-R)	$0.64 N_v$

Trenching

Soil conditions along the chosen project alignment appear to be relatively uniform and not favorable for unsupported vertical trench cuts more than approximately 5 feet deep. Review of

the available data indicates that there is no easily discernible pattern to the occurrence of silty soils which are more favorable to trench stand-up time. A good example of this is from the geotechnical investigation we reviewed for General Jim Moore Boulevard where borings drilled at approximately 1,000-foot spacing revealed sands with fines content varying from 3 to 10 percent and moisture contents generally less than 5 percent. At the north end of the alignment an investigation for the Regional Wastewater management system yielded similar results. It is interesting to note that this latter investigation included test pits. The pits encountered essentially the same material type. One pit caved, and one did not.

Recent construction related to the recycled water pipeline encountered varying soil conditions with both dry clean flowing sands and moist relatively silty sands present in these trenches. Figures 8 through 10 present photos taken by others at construction sites in the area during trenching or grading activities.

At this time we can not differentiate different reaches of the project where flowing sand will or will not be encountered. Due to the nature of the sand deposition, there likely are local areas historically dominated by transient dunes where loose, dry, clean sand exists. There are also historic low areas where more silty sands may have accumulated. Also, areas likely exist where grading for the development of the streets and the military base has altered the natural deposition. We attempt to identify areas of varying conditions; however, for construction purposes, conditions likely will vary over short distances and are difficult to characterize. One area that seems to consistently have a layer of problematic dry caving soils is near the locations of Borings B-5 and B-6. These borings found a layer of dry, silty sand, which was prone to caving, even within our small diameter borings. This section of the pipeline alignment appears to lie entirely beneath graded dirt roads with limited existing utility conflicts; however, the exact extents of this layer can not be determined at this time and it may potentially extend beneath adjacent paved roads (i.e. near CSUMB and the north end of General Jim Moore Boulevard) where utility conflicts and asphalt replacement may be more problematic.

As a general guide, the color appears to be indicative of silt and fines content in the encountered soils. Soil with higher silt and fines content (on the order of 10 percent) was generally slightly darker (brown to olive brown) than the cleaner sands which tended to be yellowish brown in color. In addition, soil with brown to olive-brown color tended to have higher moisture content, on the order of 3 to 5 percent higher than the yellowish brown soils encountered. This moisture will aid in stand-up time; however, it should not be counted upon by the contractor for temporary slopes.

Corrosion Potential

An evaluation of possible corrosion impacts to the pipeline was conducted by JDH Corrosion Consultants Inc. Their findings were based upon samples taken from our field exploration and delivered to Serco Labs.

In general, the analysis by JDH found low corrosion potential for soils throughout the project alignment. Soils found in the “Armstrong Ranch” portion of the pipeline alignment tend to be slightly siltier than those along the rest of the alignment and have a slightly higher corrosion potential. Please refer to the JDH report for specific conclusions and recommendations regarding corrosive soils.

RECOMMENDATIONS

General

It is our opinion that the proposed development is feasible from a geotechnical standpoint, provided the recommendations included in this report are followed.

Structures

The project will include a pump station serving the recycled water line near the intersection of 3rd Street and 5th Avenue. Design recommendations for the pump station are presented in the following sections.

Grading. In general, grading for the pump station will consist of minor cuts and fills. Areas where improvement will be constructed or paved should be stripped to remove surface vegetation and organic topsoil or existing paving as applicable. Native soil from these sites may be stockpiled for subsequent use as structural fill or backfill, if needed. Excess over-sized material should be wasted off-site or, if so required by the Project (Landscape) Architect, stockpiled for subsequent use in the construction of landscape features. Trees (and shrubs) designated for removal on the Project Plans should be felled and their stumps and roots should be grubbed. Utility lines, (leach lines, sanitary sewers and storm drains) designated for abandonment on the Project Plans, should be dug out, removed, and the resulting voids backfilled.

5th Avenue Pump Station Foundations. We conclude that a structural mat foundation can be used to support the proposed pump station at 5th Avenue and 3rd Street. A minimum slab thickness of 8 inches is recommended. The perimeter should be thickened to at least 20 inches, and the

minimum backfill height of soil against the slab at the perimeter should be 12 inches. An above-grade waffle mat with voids between the ribs would also be appropriate at the site.

The structural slab should be designed to impose a maximum allowable bearing pressure of 2,500 pounds per square foot (psf) for dead-plus-live loads. This value may be increased by one-third when considering total loads including wind or seismic loads. The subgrade material under the structural mat should be uniform. The top 12 inches of pad subgrade should be moisture conditioned to a moisture content of at least optimum and compacted to 90 percent relative compaction. Where floor coverings are anticipated, we recommend that the concrete be underlain by a tough, vaporproof membrane at least 10 mils thick to minimize moisture condensation under the floor coverings.

Lateral loads can be resisted by a combination of passive pressure acting on the vertical faces of the footings and friction along the bases of the footings. Passive resistance may be calculated using an equivalent fluid weight (triangular distribution) of 350 pounds per cubic foot (pcf). The upper one foot of soil should be ignored unless it is confined by slabs or pavement. Frictional resistance should be computed using a base friction coefficient of 0.40 (0.2 if waterproofing membrane is placed below the mat). These values include a factor of safety of about 1.5. Footings located adjacent to utility trenches should bear below an imaginary 1.5:1 (horizontal:vertical) plane projected upward from the bottom edge of the adjacent trench.

Pump support pads may be designed using an equivalent modulus of elasticity (E_s) of 900,000 psf, and a Poisson's ratio of 0.3.

We should observe mat subgrade prior to placement of reinforcing steel. The excavation for the mat should be free of standing water, debris, and disturbed materials prior to placing concrete. The final foundation plans should be reviewed by the Geotechnical Engineer when they become available to check for conformance with these recommendations.

Surface Drainage. Areas adjacent to the improvements should be positively graded at all times to provide for rapid removal of surface water runoff away from the foundation systems and open trenches and to prevent ponding of water under floors or seepage toward foundation systems or open trenches at any time during or after construction. Excessive water could cause trench slope instability. Care should be exercised to ensure that landscape mounds or walkways will not interfere with this requirement.

As a minimum requirement, finished grades should have slopes of at least 5 percent within 5 feet from exterior walls and at right angles to them to allow surface water to drain positively away from structures. For paved areas, the slope gradient can be reduced to 2 percent. All surface water should be collected and discharged into the storm drain system.

All improvements should be protected against the surface run-off from adjacent uphill property; the Civil Engineer should be consulted on this matter. No water should be allowed to discharge in a concentrated manner over downhill slopes as this could cause erosion.

Retaining Walls and Basement Walls. The native excavated soil can be reused as backfill material behind retaining walls. Import backfill material should be non-expansive, defined as soil having a liquid limit less than 40 and a plasticity index less than 12. Backfill should be placed in layers less than 8 inches thick prior to compaction, and compacted to at least 90 percent relative compaction. Light compaction equipment should be used within 5 feet of the walls. Prior to installation of any basement retaining walls, the site should be open cut at a slope of at least 1.5:1, or temporarily shored.

Walls that are restrained from rotation at the top, such as basement walls, should be designed using at-rest pressures corresponding to an equivalent fluid unit weight of 55 pcf. Where walls

are not restrained from rotation at the top, such as roadside retaining walls, they should be designed using active earth pressures corresponding to an equivalent fluid unit weight of 35 pcf. Passive resistance at the toe of the wall may be calculated using an equivalent fluid unit weight of 350 pcf. Where traffic is expected within a distance equal to the height of the walls, they should be designed for an additional uniform lateral pressure of 100 psf to be applied over the entire height of the wall or 10 feet, whichever is less.

For seismic conditions, the incremental dynamic force along the face of a retaining wall or basement wall should be calculated as follows:

$$\Delta P = 12 \times H^2$$

Where H is the design height of the wall (in feet) and ΔP is the incremental seismic force in pounds per foot of wall. This force has a horizontal direction and should be applied at $0.6 \times H$ from the base of the wall.

The lateral earth pressures recommended are for walls without hydrostatic pressure, that is they are back drained to prevent the buildup of hydrostatic pressure. We expect that all backfill will be native, free-draining sand, which will be acceptable to assume a drained wall.

Pipeline Design

The pipe should be designed to resist loads imposed on overlying soil cover and from vehicle or construction traffic. Soil loads may be calculated using a total unit weight of 110 pounds per cubic foot. Where the pipeline changes direction, thrust will tend to move the pipe. These movements can be resisted by friction between the pipe and the surrounding fill, with restrained joints, and/or with thrust blocks. We recommend that frictional resistance be calculated using a friction coefficient of 0.4 for ductile iron pipe or concrete. Frictional resistance for steel pipe can be calculated using a coefficient of 0.3.

Where hydraulic forces tend to move the pipe in an upward direction, as at vertical curves or vertically bent fittings, movement can be resisted by the weight of the pipe, its contents, and the overlying soils. To determine weight of the overlying soils, use an effective total unit weight of 110 pounds per cubic foot for soil above the water table.

We do not anticipate that the pipeline will be installed below the groundwater table in any section of the alignment. Soils in the vicinity of Reservation and Beach Roads are in an area of known liquefaction hazard due to the shallow groundwater table in this area (approximately 10 feet below grade at the western extreme of the pipeline design reach). In the event that portions of the pipeline are installed below groundwater, portions of the pipeline could become buoyant due to liquefaction. Uplift due to liquefaction could cause some pipeline deflection.

In addition, some limited amount of seismic settlement is likely to occur along the pipeline alignment in a seismic event due to 1) densification of loose, dry to slightly moist, poorly graded dune sands beneath and around the proposed pipeline and 2) liquefaction in the areas described above. Densification/liquefaction of the sands could result in seismically induced settlement of the pipeline up to 1 inch. Differential settlement on the order of 0.5 inch in 50 feet is possible.

It is our understanding that the standard MCWD trenching and backfilling specifications as found on the official website will be used for this project. In addition, native soils will be used for trench back fill as much as possible. We recommend no changes to the Standard Specification Section 02223 and conclude that 95 percent relative compaction within the street zone should be appropriate. Native materials should be suitable backfill material in virtually all areas of the alignment. If import material is used for pipe zone backfill, we recommend it consist of fine- to medium-grained sand or a well-graded mixture of sand and gravel.

Based on the conditions encountered in the test borings we have estimated the range of the modulus of soil reaction E' for checking the load-deflection behavior of flexible pipe. In practice E' values for pipeline design should consider a number of factors including soil type, native soil density, trench backfill type and compaction, pipe size, cover depth, trench width and other factors. The range of E'_n (the modulus of soil reaction for the native soil) is estimated to be between 1,000 and 1,500 psi. These values should be modified for trench width and bedding conditions and other factors, as appropriate.

Trench Excavation and Shoring

It is our opinion that the pipeline construction can be accomplished using sloped open cuts and a hybrid trapezoidal trench backfill section. This may result in conflicts where adjacent utilities exist within the trench influence zone and will result in a larger area of street reconstruction than would vertical trenches. In some areas, particularly where shallow trenches are feasible, trenches may stand open vertically a sufficient amount of time to allow for the use of internal shoring (plywood and speed shores/cribbing). This configuration will likely be unacceptable where utilities are located within the influence zone of the trench. This hybrid trench section is anticipated to be necessary in paved areas, whereas a typical fully sloped back section can be used in unpaved areas, provided utility conflicts are not present.

The Marina Coast Water District's standard specifications for recycled water pipelines prescribe minimum cover of 48 inches above the pipe (including an assumed 12-inch pavement section). This implies a trench depth of 6 to 7 feet to the bottom of pipe bedding. Based on these dimensions and approximately 6 inches of clearance on either side of the pipe, we anticipate that an open cut hybrid trench section with sides sloped at 1.5:1, as prescribed by OSHA for type C soils, can be constructed with a minimum saw cut of approximately 11 feet, edge to edge. This would include an approximately 3 to 4 foot vertical cut from the bottom of the trench to the beginning of the side slopes.

In turn, existing utilities should have at least 1 foot of cover in the temporary cut, meaning that utilities with adequate vertical cover could be unaffected within 2 to 3 feet of the trench walls, and not have to be replaced. This would, of course, be dependent on the soils remaining in place and not sloughing into the excavation, which is possible throughout the alignment. For planning purposes, we anticipate that an 8-foot zone clear of existing utilities centered along the pipeline will be sufficient to avoid significant removal and replacement activity due to disturbance by trenching activity.

In areas where sloped open cuts utilizing internal shoring at the contractor's risk is not feasible, there are several options:

- Sheet piling could be driven utilizing a trench shield as cross bracing. The sheeting could be driven using a vibratory attachment for an excavator and would not require mobilization of large driving equipment. Sheeting would only have to be driven to the depth of the trench bottom. This may prove more cost effective than removal and replacement, and its use should be evaluated by the design team based on the anticipated areas and extent of utility conflicts.
- Remove and replace or relocate selected utilities and use sloped open cuts.
- Selected reaches of trenchless construction, as needed (i.e. bore-and-jack construction).

Trenchless construction will have the same constraints on the bore-and-jack pit in terms of sloughing and temporary slopes as would open cut trenches.

It is recommended that pipeline trench backfilling be done under the observation of a Geotechnical Engineer or their qualified representative. Trenches should be kept open only long enough to properly install the pipe and backfill. All trenches and construction slopes should be backfilled as soon as possible. The design excavation depth should include an additional 6 inches below the pipe invert to account for bedding material requirements. Shoring design

calculations, plans, and specifications should be reviewed by the project Geotechnical Engineer prior to final design and construction.

Trenching conducted during wet weather with significant rainfall will be difficult and the trench walls will tend to collapse if left open. All surface water should be diverted away from the trench and the trench should be covered. Soil stockpiles should also be covered.

It should be noted that where the pipeline trench is planned to enter areas with a high groundwater table, dewatering may be necessary. Dewatering will likely produce relatively high flow rates due to the high permeability of the native soil (on the order of 10^{-1} to 10^{-3} cm/s). In addition, the bottom of deep utility trenches may heave and cause the trench to collapse as a result of the high groundwater level. In some cases, groundwater control systems will need to be installed and operated outside of the limits of the bore-and-jack and trench excavations. The groundwater control system(s) should be designed by an experienced specialty contractor experienced with similar subsurface conditions. In addition, the contractor should evaluate the possible effects of the selected groundwater control method on the stability of the shoring systems.

Care should be exercised where trenches are located adjacent to existing foundation areas. Utility trenches constructed parallel to foundations should be located entirely above a plane extending down from the lower edge of the footing at an angle of 45 degrees.

Utility trenches in areas to be paved in the future should be constructed in accordance with the requirements of the appropriate jurisdictions. Identified jurisdictions that the alignment passes through include the City of Marina, the City of Seaside, the Base Realignment and Closure commission (BRAC), CSUMB, and private owners in the Armstrong Ranch area and the Fitch Park area. Compaction of native trench backfill by jetting should not be allowed at the site. If there appears to be a conflict between City or other jurisdictional requirements and the

recommendations contained in this report, this should be brought to the Marina Coast Water District's attention for resolution prior to submitting bids.

Pavement Design Recommendations

Based on the soil conditions encountered in the exploratory borings, an R-value of 50 may be assumed for the sandy soils encountered along the proposed alignment. The Traffic Index should be determined by the Civil Engineer or appropriate public agency. Actual pavement sections to be used should be based on R-value tests performed on samples of actual subgrade materials recovered at the time of grading.

Pavement materials and construction should conform to the specifications and requirements of the appropriate regulatory and local agencies, and the following minimum requirements.

- Sandy subgrades should be compacted to at least 95 percent relative compaction at or above optimum moisture content.
- All soil should be placed as engineered fill at project specifications during grading. If the site soil is found to be loose, it may have been disturbed by utility installation. All structural subgrade soils should be returned to project compaction and moisture specifications prior to placement of aggregate base.
- Aggregate baserock materials should meet current requirements for Class 2 aggregate baserock in the appropriate jurisdictions (City of Marina, City of Seaside, CalTrans, BRAC, CSUMB, etc.) and should be compacted to at least 95 percent of maximum dry density at optimum water content or higher. The CalTrans specification should be adequate where jurisdictional requirements are unknown.
- Asphalt paving materials should meet current Caltrans specifications for asphalt concrete.

LIMITATIONS AND UNIFORMITY OF CONDITIONS

The professional staff of ENGEO Incorporated strives to perform its services in a proper and professional manner with reasonable care and competence but is not infallible. There are risks of earth movement and property damages inherent in land development. We are unable to eliminate all risks or provide general insurance; therefore, we are unable to guarantee or warrant the results of our work. Our services consist of professional opinions, conclusions, and recommendations that are made in accordance with generally accepted geotechnical engineering principles and practices. This warranty is in lieu of all other warranties, either expressed or implied.

Variations may exist and conditions not observed or described in this report could be encountered during construction. Our conclusions and recommendations are based on the observed conditions. If conditions other than those described in this report are encountered, we should be notified so that additional recommendations, if warranted, can be provided. If ENGEO's scope of services does not include on-site construction observation, or if other persons or entities are retained to provide such services, ENGEO cannot be held responsible for any or all claims arising from or resulting from the performance of such services by other persons or entities, and from any or all claims arising from or resulting from clarifications, adjustments, modifications, discrepancies or other changes necessary to reflect changed field or other conditions.

This report has been prepared for the exclusive use of RMC Water and Environment, Inc, and the Marina Coast Water District, and its agents for the specific application to the Marina Coast Recycled Water Pipeline Project as referenced. In the event that there are any changes in the project design team, nature, design, or location of the project, or if any future modifications are planned, the conclusions and recommendations contained in this report should not be considered valid unless (1) the project changes are reviewed by ENGEO Incorporated, and (2) conclusions

and recommendations presented in this report are modified or verified in writing. Reliance on this report by others must be at their risk, unless we are consulted on its use or limitations. We cannot be responsible for the impacts of any changes in geotechnical standards, practice, or regulations subsequent to the performance of our services without our further consultation. We can neither vouch for the accuracy of information supplied by others, nor accept consequences for un-consulted use of segregated portions of this report.

DRAFT

SELECTED REFERENCES

- Blake, T. F., 1996, EQFAULT, A Computer Program for the Deterministic Prediction of Peak Horizontal Acceleration from Digitized California Faults.
- Clark J.C., Dupre, W.R., and Rosenberg, L. I., 1997, Monterey Quadrangle, USGS, OFR 97-30.
- Clark J.C., Dupre, W.R., and Rosenberg, L. I., 1997, Seaside Quadrangle, USGS, OFR 97-30.
- Dibblee, T.W., 1973, Geologic Map of the Monterey Quadrangle, California, USGS, OFR 74-1021.
- Idriss, I. M., 1994, Procedures for Selecting Earthquake Ground Motions at Rock Sites, National Institute of Standards and Technology, GCR 93-625.
- Ishihara, K., 1985, stability of Natural deposits during Earthquakes; Proceedings of the Eleventh International Conference on Soil Mechanics and Foundation Engineering.
- JDH Inc., 2006; Soil Corrosivity Evaluation & Recommendations for Corrosion Control, Regional Urban Water Augmentation Project, Ph. 2, Marina Coast Water District, prepared for Carollo Engineers, Dated January 3, 2007.
- Kleinfelder, 2005; Geotechnical Investigation Proposed East Garrison, "B" Zone Tanks, "D" Zone Reservoirs, "E" Zone Hydropneumatic Pump Station, and Transmission Mains, Marina Coast Water District, Marina, California, Prepared by Kleinfelder Inc., September 28, 2005.
- MCWD, 2005, Urban Water Management Plan, prepared by Byron Buck and Associates.
- Seed, H. B., K. Tokimatsu, L. F. Harder and R. M. Chung, 1985, Influence of SPT Procedures in Soil Liquefaction Resistance Evaluations, Journal of Geotechnical Engineering, ASCE.
- Tokimatsu, K. and H. B. Seed, 1987, Evaluation of Settlements in Sands due to Earthquake Shaking, Journal of Geotechnical Engineering, American Society of Civil engineers, Vol. 113, No. 8, pp. 861-878.
- Wagner, D., 2002, Geologic Map of the Monterey 30' x 60' Quadrangle and Adjacent Areas, California, California Geologic Survey.

LIST OF FIGURES AND TABLES

Figure 1	Vicinity Map
Figure 2	Project Alignment
Figure 3	Geologic Map
Figure 4	Regional Faulting and Seismicity
Figure 5	Existing Geotechnical Information
Figure 6	Pavement Coring Locations
Figure 7	Boring Locations
Figure 8	Site Photographs (1)
Figure 9	Site Photographs (2)
Figure 10	Site Photographs (3)
Table I	Summary of Laboratory Test Results

COPYRIGHT © 2007 BY ENGeo INCORPORATED. THIS DOCUMENT MAY NOT BE REPRODUCED IN WHOLE OR IN PART BY ANY MEANS WHATSOEVER, NOR MAY IT BE QUOTED OR EXCERPTED WITHOUT THE EXPRESS WRITTEN CONSENT OF ENGeo INCORPORATED.

DRAFT

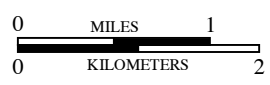

DRAFT

BASE MAP SOURCE: MS STREETS AND TRIPS



VICINITY MAP
MARINA COAST RECYCLING WATER PIPELINE
MARINA, CALIFORNIA

PROJECT NO.:	7496.1.003.01
DATE:	AUGUST 2007
DRAWN BY:	PC
CHECKED BY:	

FIGURE NO.
1

DRAFT

G:\Drawing\Drafting\7496\003\ENX\7496100301-2-Pro\align-0807.dwg 8-07-07 03:34:24 PM



EXPLANATION

- DESIGNED BY OTHERS
- EXISTING RW PIPELINE
- TRANSMISSION MAIN
- LATERALS

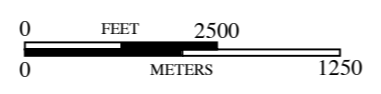

BASE MAP SOURCE: USGS, TERRASERVER, 1998



PROJECT ALIGNMENT
 MARINA COAST RECYCLED WATER PIPELINE
 MARINA, CALIFORNIA

PROJECT NO:	7496.1.003.01
DATE:	AUGUST 2007
DRAWN BY:	PC
CHECKED BY:	

FIGURE NO.
2

DRAFT

G:\Drafting\Drafting\Drawings\7496\003\GEO\749600301-3-GeologicMap-0807.dwg 8-07-07 03:36:01 PM

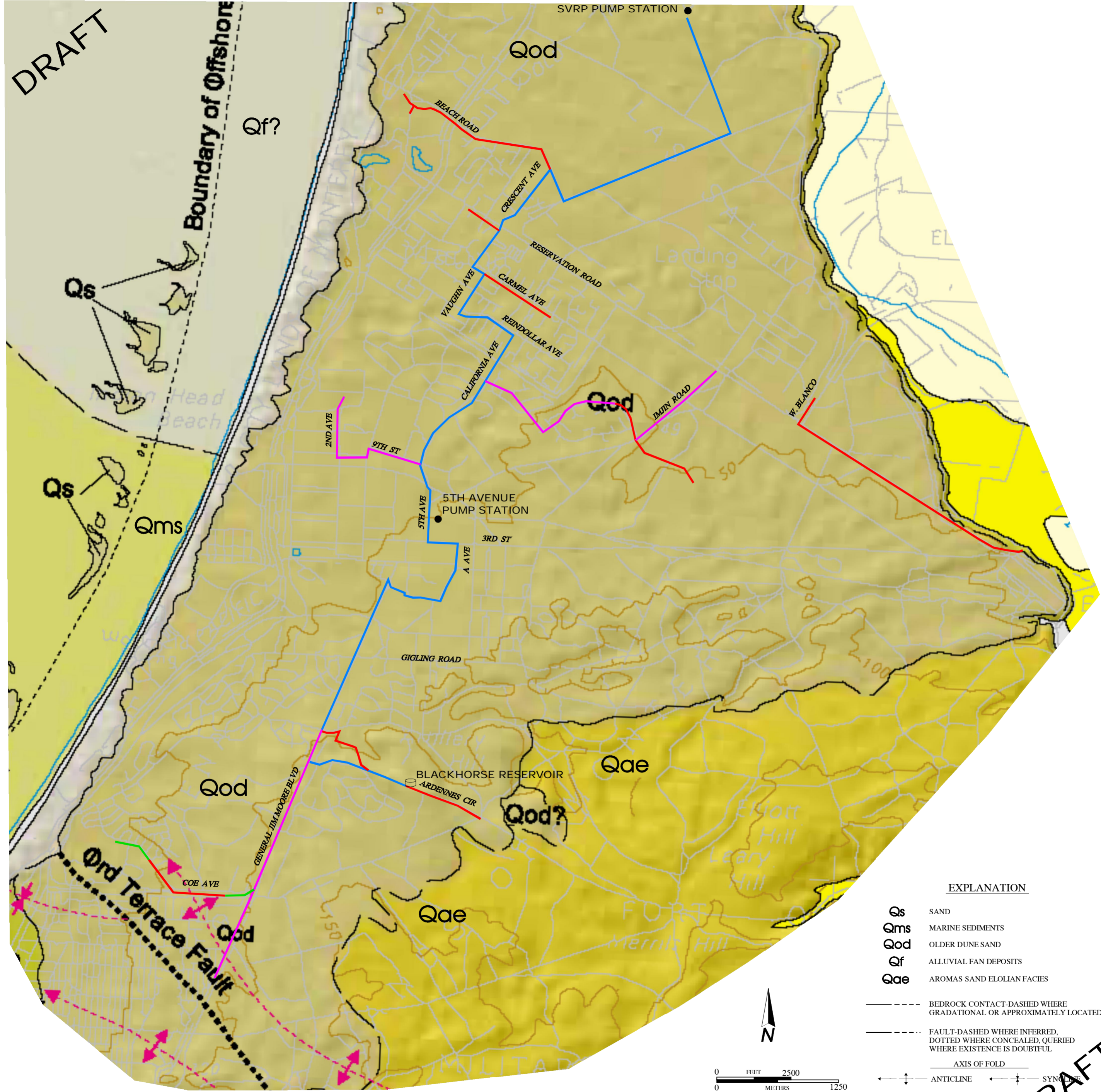

DRAFT

EXPLANATION

- Qs** SAND
- Qms** MARINE SEDIMENTS
- Qod** OLDER DUNE SAND
- Qf** ALLUVIAL FAN DEPOSITS
- Qae** AROMAS SAND ELOLIAN FACIES

- BEDROCK CONTACT-DASHED WHERE GRADATIONAL OR APPROXIMATELY LOCATED
- FAULT-DASHED WHERE INFERRED, DOTTED WHERE CONCEALED, QUERIED WHERE EXISTENCE IS DOUBTFUL

- AXIS OF FOLD
- ↕ ANTICLINE ↔ SYNCLINE

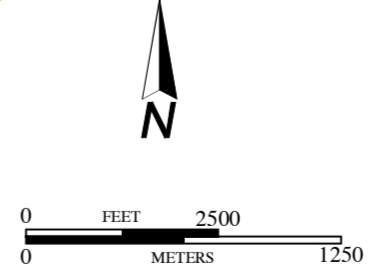

BASE MAP SOURCE: WAGNER, 2002



REGIONAL GEOLOGIC MAP
MARINA COAST RECYCLED WATER PIPELINE
MARINA, CALIFORNIA

PROJECT NO: 7496.003.01
DATE: AUGUST 2007
DRAWN BY: PC CHECKED BY:

FIGURE NO.
3

DRAFT

COPYRIGHT © 2007 BY ENGEO INCORPORATED. THIS DOCUMENT MAY NOT BE REPRODUCED IN WHOLE OR IN PART BY ANY MEANS WHATSOEVER, NOR MAY IT BE QUOTED OR EXCERPTED WITHOUT THE EXPRESS WRITTEN CONSENT OF ENGEO INCORPORATED.

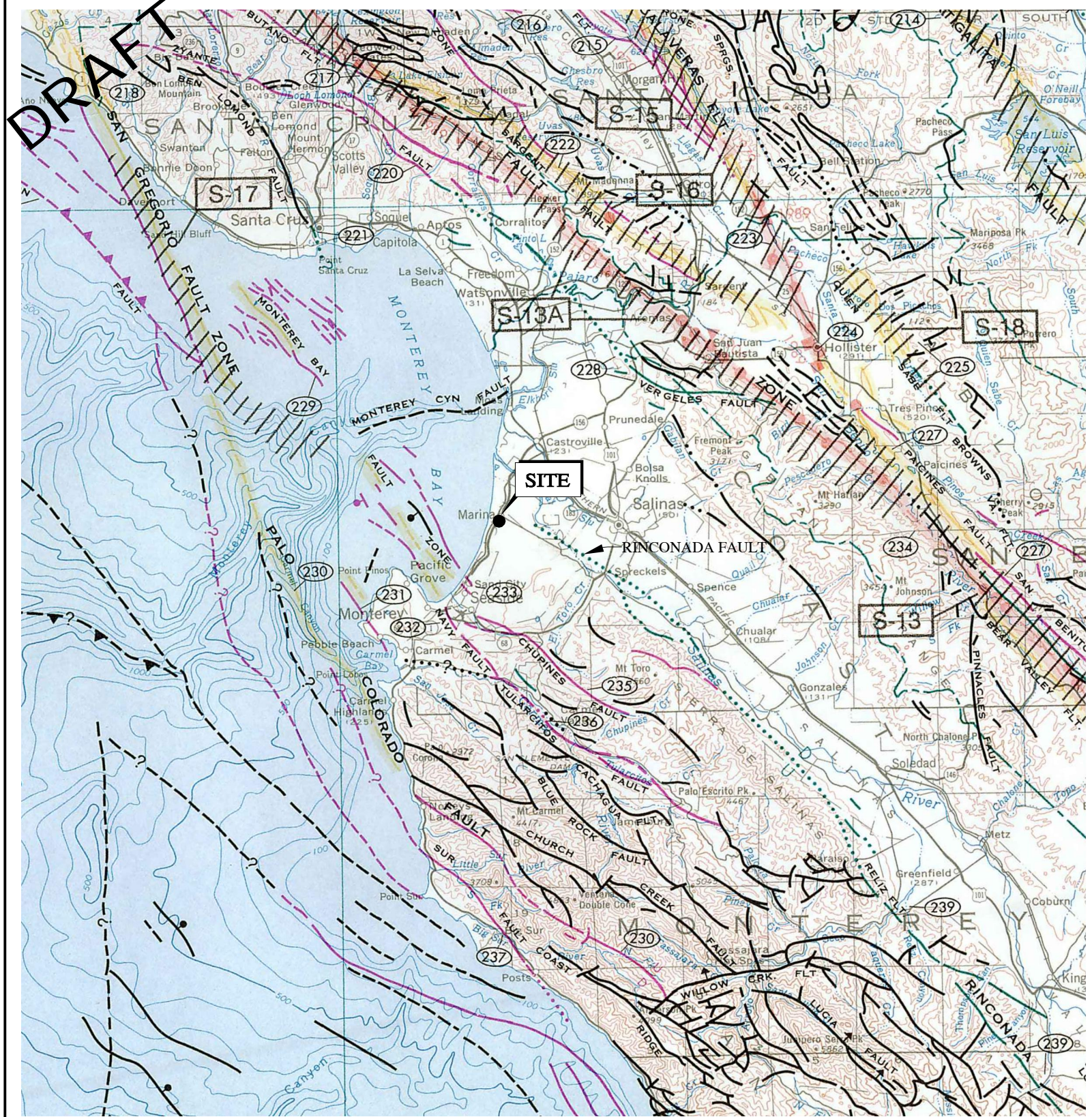

EXPLANATION

Fault traces on land are indicated by solid lines where well located, by dashed lines where approximately located or inferred, and by dotted lines where concealed by younger rocks or by lakes or bays. Fault traces are queried where continuation or existence is uncertain. Concealed faults in the Great Valley are based on maps of selected subsurface horizons, so locations shown are approximate and may indicate structural trend only. All offshore faults based on seismic reflection profile records are shown as solid lines where well defined, dashed where inferred, queried where uncertain.

FAULT CLASSIFICATION COLOR CODE
(Indicating Recency of Movement)

- Fault along which historic (last 200 years) displacement has occurred and is associated with one or more of the following:
 - (a) a recorded earthquake with surface rupture. (Also included are some well-defined surface breaks caused by ground shaking during earthquakes, e.g. extensive ground breakage, not on the White Wolf fault, caused by the Arvin-Tehachapi earthquake of 1952). The date of the associated earthquake is indicated. Where repeated surface ruptures on the same fault have occurred, only the date of the latest movement may be indicated, especially if earlier reports are not well documented as to location of ground breaks.
 - (b) fault creep slippage – slow ground displacement usually without accompanying earthquakes.
 - (c) displaced survey lines.
- Pink band — added to emphasize location of historic fault displacement.

SPECIAL NOTATIONS

- A triangle to the right or left of the date indicates termination point of observed surface displacement.
- Date bracketed by triangles indicates local fault break.
- No triangle by date indicates an intermediate point along fault break.
- Dot on fault indicates location where fault creep slippage has been observed and recorded.
- Square on fault indicates where fault creep slippage has occurred that has been triggered by an earthquake on some other fault. Date of causative earthquake indicated. Squares to right and left of date indicate terminal points between which triggered creep slippage has occurred (creep either continuous or intermittent between these end points).

ADDITIONAL FAULT SYMBOLS

- U = Uplifted side (relative or apparent)
- D = Downthrown side (relative or apparent)
- Bar and ball on downthrown side (used where space is limited).
- Arrows along fault indicate relative or apparent direction of lateral movement.
- Arrow on fault indicates direction of dip.
- Low angle fault (barbs on upper plate). Fault surface generally dips less than 45° but locally may have been subsequently steepened. On offshore faults, barbs simply indicate a reverse fault regardless of steepness of dip.

OTHER SYMBOLS

- Numbers refer to annotations listed in the Appendices of the accompanying report. Annotations include fault name, age of fault movement, and pertinent references including Earthquake Fault Zone maps where a fault has been zoned by the Alquist-Priolo Earthquake Fault Zoning Act. This Act requires the State Geologist to delineate zones to encompass all potentially and recently active faults.
- Cinder cone and other types of volcanoes. Most were active in Pleistocene time, some are Holocene, a few are historic.
- Number in box or circle refers to Table 4 (Recent Volcanic Eruptions) in accompanying report. (Box refers to California, circle to Nevada.)
- (1786 A.D.) = Date of historic volcanic eruption.
- (9,500 B.P.) = Eruption occurrence in years before present (B.P.).
- (0.5 m.y.) = Age of volcanic flow or eruption in million years (m.y.).

Fault segment associated with a significant linear trend of accurately located earthquake epicenters (magnitude 0.2 or greater). Generally aligned along strike slip faults having Quaternary displacement, but not necessarily with historic surface rupture. Lack of seismic activity along any fault is no indication that the fault may not be active in the future (e.g. San Andreas fault north of San Francisco). Epicenter data are derived from closely spaced seismic stations and include either continuing microseismicity or aftershocks associated with relatively large earthquakes.

Aligned seismicity on fault segments are referenced in Appendices C and E.



BASE MAP SOURCE: JENNINGS, 1994



REGIONAL FAULT MAP
MARINA COAST RECYCLED WATER PIPELINE
MARINA, CALIFORNIA

PROJECT NO.:	7496.1.003.01	FIGURE NO.:	4
DATE:	AUGUST 2007		
DRAWN BY:	PC	CHECKED BY:	

DRAFT

DRAFT

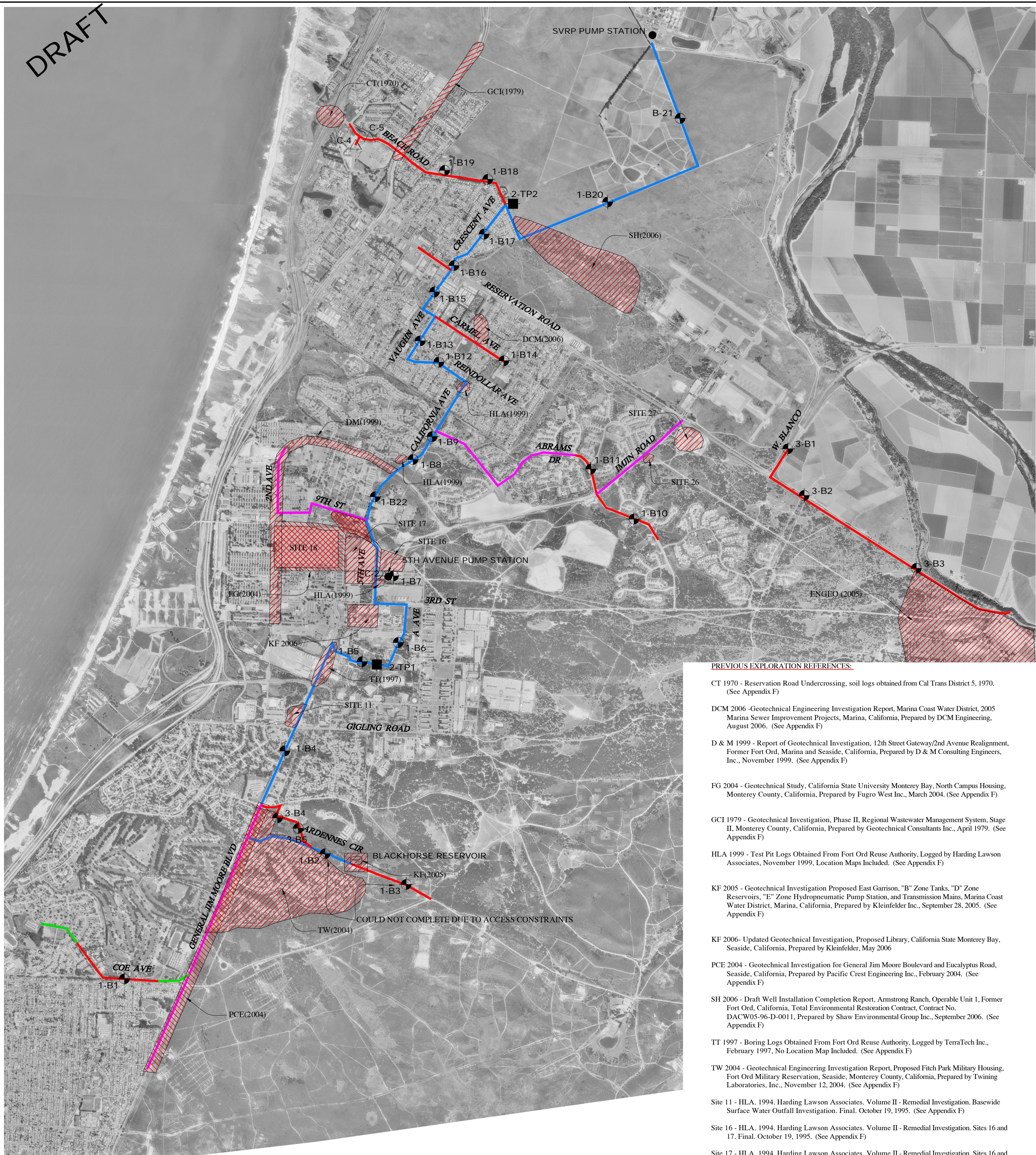

PREVIOUS EXPLORATION REFERENCES:

- CT 1970 - Reservation Road Undercrossing, soil logs obtained from Cal Trans District 5, 1970. (See Appendix F)
- DCM 2006 - Geotechnical Engineering Investigation Report, Marina Coast Water District, 2005 Marina Sewer Improvement Projects, Marina, California, Prepared by DCM Engineering, August 2006. (See Appendix F)
- D & M 1999 - Report of Geotechnical Investigation, 12th Street Gateway/2nd Avenue Realignment, Former Fort Ord, Marina and Seaside, California, Prepared by D & M Consulting Engineers, Inc., November 1999. (See Appendix F)
- FG 2004 - Geotechnical Study, California State University Monterey Bay, North Campus Housing, Monterey County, California, Prepared by Fugro West Inc., March 2004. (See Appendix F)
- GCI 1979 - Geotechnical Investigation, Phase II, Regional Wastewater Management System, Stage II, Monterey County, California, Prepared by Geotechnical Consultants Inc., April 1979. (See Appendix F)
- HLA 1999 - Test Pit Logs Obtained From Fort Ord Reuse Authority, Logged by Harding Lawson Associates, November 1999, Location Maps Included. (See Appendix F)
- KF 2005 - Geotechnical Investigation Proposed East Garrison, "B" Zone Tanks, "D" Zone Reservoirs, "E" Zone Hydropneumatic Pump Station, and Transmission Mains, Marina Coast Water District, Marina, California, Prepared by Kleinfelder Inc., September 28, 2005. (See Appendix F)
- KF 2006 - Updated Geotechnical Investigation, Proposed Library, California State Monterey Bay, Seaside, California, Prepared by Kleinfelder, May 2006
- PCE 2004 - Geotechnical Investigation for General Jim Moore Boulevard and Eucalyptus Road, Seaside, California, Prepared by Pacific Crest Engineering Inc., February 2004. (See Appendix F)
- SH 2006 - Draft Well Installation Completion Report, Armstrong Ranch, Operable Unit 1, Former Fort Ord, California, Total Environmental Restoration Contract, Contract No. DACW05-96-D-0011, Prepared by Shaw Environmental Group Inc., September 2006. (See Appendix F)
- TT 1997 - Boring Logs Obtained From Fort Ord Reuse Authority, Logged by TerraTech Inc., February 1997, No Location Map Included. (See Appendix F)
- TW 2004 - Geotechnical Engineering Investigation Report, Proposed Fitch Park Military Housing, Fort Ord Military Reservation, Seaside, Monterey County, California, Prepared by Twining Laboratories, Inc., November 12, 2004. (See Appendix F)
- Site 11 - HLA, 1994. Harding Lawson Associates. Volume II - Remedial Investigation. Basewide Surface Water Outfall Investigation. Final. October 19, 1995. (See Appendix F)
- Site 16 - HLA, 1994. Harding Lawson Associates. Volume II - Remedial Investigation. Sites 16 and 17. Final. October 19, 1995. (See Appendix F)
- Site 17 - HLA, 1994. Harding Lawson Associates. Volume II - Remedial Investigation. Sites 16 and 17. Final. October 19, 1995. (See Appendix F)
- Site 18 - HLA, 1994. Harding Lawson Associates. Volume IV - Baseline Ecological Risk Assessment. Final. October 19, 1995. (See Appendix F)
- Site 25 - HLA, 1994. Harding Lawson Associates. Volume IV - Baseline Ecological Risk Assessment. Final. October 19, 1995. (See Appendix F)
- Site 26 - HLA, 1994. Harding Lawson Associates. Volume IV - Baseline Ecological Risk Assessment. Final. October 19, 1995. (See Appendix F)
- Site 27 - HLA, 1994. Harding Lawson Associates. Volume IV - Baseline Ecological Risk Assessment. Final. October 19, 1995. (See Appendix F)
- ENGO 2005 - ENGO Incorporated Geotechnical Exploration, East Garrison, Fort Ord, Monterey, California, Project NO. 5866.3.001.01, July 28, 2005

EXPLANATION

- DESIGNED BY OTHERS
- EXISTING RW PIPELINE
- TRANSMISSION MAIN (16-20"Ø)
- LATERALS (4-12"Ø)
- 2-TP2 ■ TEST PIT (ENGO, 2006)- TO BE COMPLETED
- C-5 ▲ CPT (LAND MARINE GEOTECHNICS, 2006)
- 1-B22 ● SOIL BORING
- APPROXIMATE EXTENT OF PREVIOUS EXPLORATION

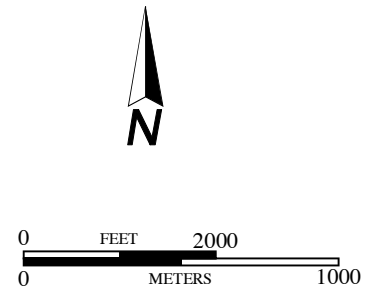

GEOTECHNICAL INVESTIGATION
MARINA COAST RECYCLED WATER PIPELINE
MARINA, CALIFORNIA

PROJECT NO:	7496.1.003.01
DATE:	AUGUST 2007
DRAWN BY:	PC
CHECKED BY:	

FIGURE NO.
5

DRAFT

DRAFT

G:\Drafting\DRAWINGS\DWG\7496\003\GEN\7496100301-5-Pavement\Coral.oc-0807.dwg 8-07-07 03:39:18 PM

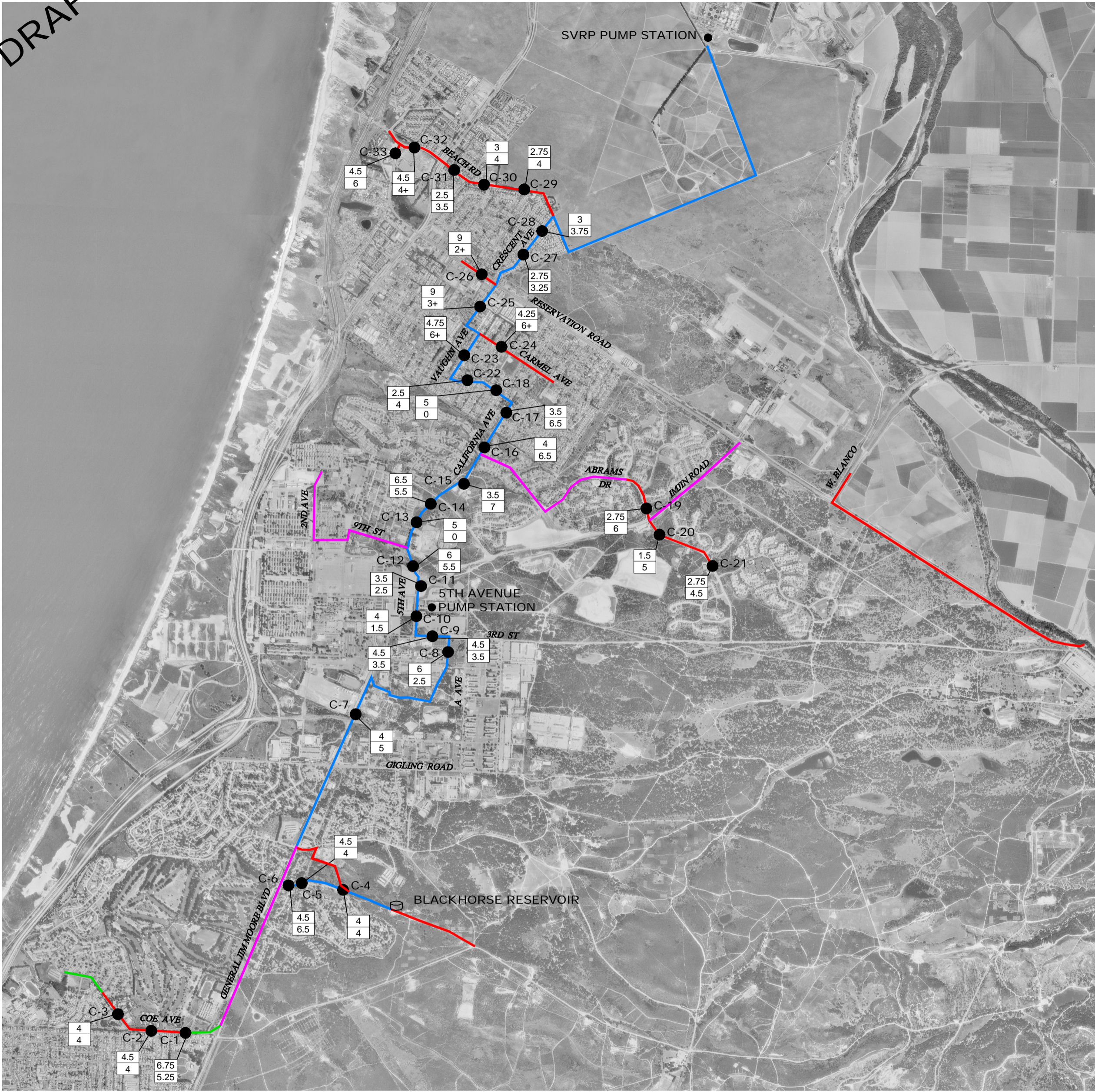

EXPLANATION

- DESIGNED BY OTHERS
- EXISTING RW PIPELINE
- TRANSMISSION MAIN
- LATERALS
- C-33 APPROXIMATE LOCATION OF PAVEMENT CORING
- 6.75 INCHES OF ASPHALT CONCRETE
- 5.85 INCHES OF AGGREGATE BASE

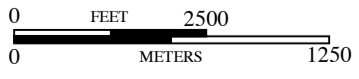

BASE MAP SOURCE: USGS, TERRASERVER, 1998



PAVEMENT CORE LOCATIONS
MARINA COAST RECYCLED WATER PIPELINE
MARINA, CALIFORNIA

PROJECT NO.: 7496.1.003.01	FIGURE NO.
DATE: AUGUST 2007	6
DRAWN BY: PC	

DRAFT

DRAFT

COE AVENUE LOCATIONS

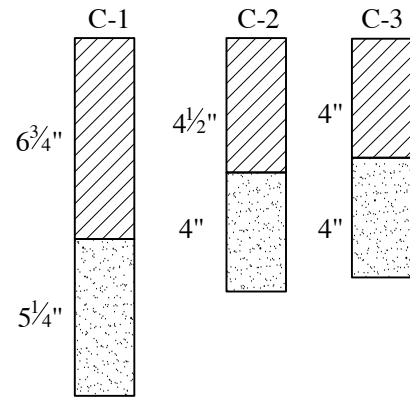

ARDENNES CIRCLE LOCATIONS

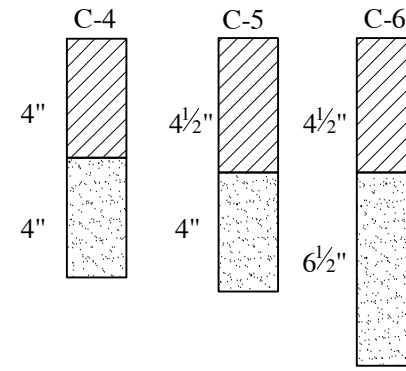

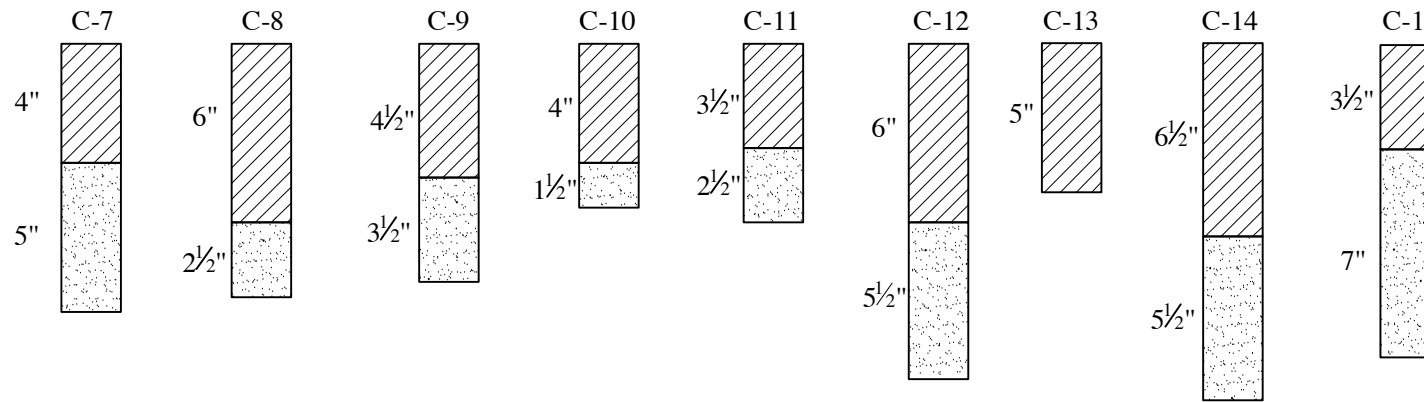

CSUMB SITES

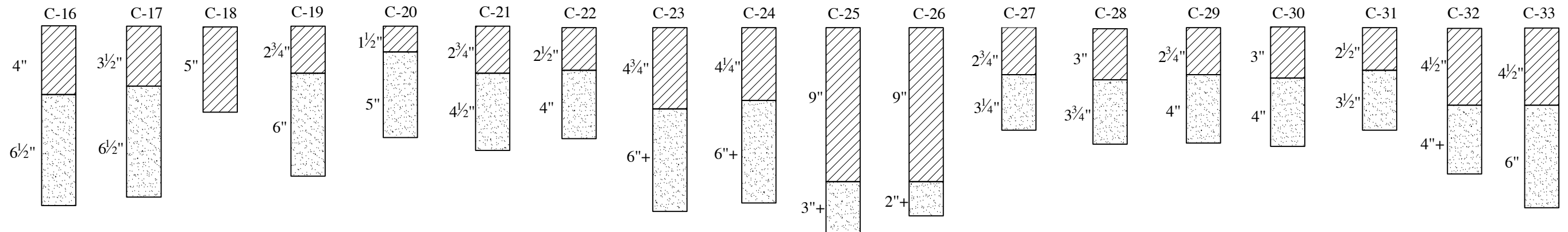

MARINA SITES



EXPLANATION

-  ASPHALT
-  AGGREGATE BASE

DRAFT



RESULTS OF PAVEMENT CORING
MARINA COAST RECYCLED WATER PIPELINE
MARINA, CALIFORNIA

PROJECT NO.: 7496.1.003.01
DATE: AUGUST 2007
DRAWN BY: PC CHECKED BY:

NO SCALE
FIGURE NO.
7

COPYRIGHT © 2007 BY ENGeo INCORPORATED. THIS DOCUMENT MAY NOT BE REPRODUCED IN WHOLE OR IN PART BY ANY MEANS WHATSOEVER, NOR MAY IT BE QUOTED OR EXCERPTED WITHOUT THE EXPRESS WRITTEN CONSENT OF ENGeo INCORPORATED.

DRAFT



CALIFORNIA AVENUE INTERSECTION #1



CALIFORNIA AVENUE INTERSECTION #2



RESERVATION ROAD CONSTRUCTION #1



RESERVATION ROAD CONSTRUCTION #2

DRAFT

PHOTO SOURCE: MARINA COAST WATER DISTRICT



SITE PHOTOGRAPHS
MARINA COAST RECYCLED WATER PIPELINE
MARINA, CALIFORNIA

PROJECT NO.: 7496.1.004.01

DATE: AUGUST 2007

DRAWN BY: PC

CHECKED BY:

FIGURE NO.

8

COPYRIGHT © 2007 BY EN GEO INCORPORATED. THIS DOCUMENT MAY NOT BE REPRODUCED IN WHOLE OR IN PART BY ANY MEANS WHATSOEVER, NOR MAY IT BE QUOTED OR EXCERPTED WITHOUT THE EXPRESS WRITTEN CONSENT OF EN GEO INCORPORATED.

DRAFT



CRESCENT AVENUE CONSTRUCTION #1



CRESCENT AVENUE CONSTRUCTION #2



CRESCENT AVENUE CONSTRUCTION #3



CRESCENT AVENUE CONSTRUCTION #4

DRAFT

PHOTO SOURCE: MARINA COAST WATER DISTRICT



SITE PHOTOGRAPHS
MARINA COAST RECYCLED WATER PIPELINE
MARINA, CALIFORNIA

PROJECT NO.: 7496.1.003.01

DATE: AUGUST 2007

DRAWN BY: PC

CHECKED BY:

FIGURE NO.

9

COPYRIGHT © 2007 BY ENGeo INCORPORATED. THIS DOCUMENT MAY NOT BE REPRODUCED IN WHOLE OR IN PART BY ANY MEANS WHATSOEVER, NOR MAY IT BE QUOTED OR EXCERPTED WITHOUT THE EXPRESS WRITTEN CONSENT OF ENGeo INCORPORATED.

DRAFT



GENERAL JIM MOORE BOULEVARD CONSTRUCTION #1



GENERAL JIM MOORE BOULEVARD CONSTRUCTION #2



GENERAL JIM MOORE BOULEVARD CONSTRUCTION #3

PHOTO SOURCE: MARINA COAST WATER DISTRICT

DRAFT



SITE PHOTOGRAPHS
MARINA COAST RECYCLED WATER PIPELINE
MARINA, CALIFORNIA

PROJECT NO.: 7496.1.003.01

FIGURE NO.

DATE: AUGUST 2007

10

DRAWN BY: PC

CHECKED BY:

TABLE 4
SUMMARY OF LABORATORY TEST RESULTS

Boring	Depth [ft]	N_{field}³ [b/ft]	N₁₍₆₀₎⁴ [b/ft]	Moisture Content [percent]	Dry Density [lb/ft³]	Percent Passing No. 200 Sieve [percent]
1-B1	3.0	32	39	3	104	12
	6.0	24	21	2	102	3
	8.0	28	21	3	102	2
	11.0	55	36	3	103	3
	16.0	46	41	5	103	-
1-B4	3.0	27	33	5	103	16
	6.0	43	37	6	104	4
	8.0	30	22	-	-	-
	10.5	84	55	6	104	3
	16.0	73	38	-	-	-
1-B5	3.0	25	32	3	97	5
	6.0	26	23	3	106	13
	8.0	29	22	6	98	5
	11.0	33	21	6	101	4
	16.0	46	25	7	103	-
1-B6	3.0	81	97	3	111	9
	6.0	40	34	3	107	16
	8.0	45	33	4	104	6
	11.0	28	18	4	99	5
	16.0	47	25	-	-	-
1-B7	2.0	55	76	6	122	10
	6.0	65	54	7	108	4
	8.0	51	37	-	-	-
	11.0	40	25	5	101	3
	16.0	23	12	-	-	-
	21.0	18	8	-	-	-
	26.0	59	24	5	104	3
1-B8	3.0	59	72	2	105	3
	5.5	39	36	2	103	2
	7.5	39	31	3	102	2
	10.5	42	28	2	104	2
	16.0	47	25	3	101	1
1-B9	3.0	47	58	2	106	1

³ Field blowcounts were almost exclusively using the California Modified Sampler

⁴ N₁₍₆₀₎ blowcounts are the field blowcounts corrected for sampler type, drill rod length, type of hammer, overburden, and borehole diameter.

TABLE 4 SUMMARY OF LABORATORY TEST RESULTS						
Boring	Depth [ft]	N _{field} ³ [b/ft]	N ₁₍₆₀₎ ⁴ [b/ft]	Moisture Content [percent]	Dry Density [lb/ft ³]	Percent Passing No. 200 Sieve [percent]
	5.5	35	32	2	106	1
	7.5	48	37	2	106	1
	11.0	60	39	2	103	2
	16.0	42	22	-	-	-
1-B10	3.0	44	52	5	110	10
	5.5	16	14	5	106	11
	7.5	25	19	3	102	1
	13.0	51	30	3	104	2
1-B11	3.0	36	46	2	98	1
	5.5	30	28	2	99	0
	7.5	41	33	2	103	1
	13.0	64	38	-	-	-
1-B12	3.0	17	21	3	101	2
	6.0	32	28	3	104	2
	7.5	45	35	-	-	-
	11.0	72	46	3	103	2
	16.0	79	42	-	-	-
1-B13	3.0	60	74	2	104	1
	5.5	39	35	-	-	-
	8.0	62	47	3	105	2
	11.0	59	38	2	103	1
	16.0	80	42	-	-	-
1-B14	3.0	25	31	4	105	4
	6.0	38	33	2	99	1
	8.0	70	53	-	-	-
	11.0	59	38	2	102	3
	16.0	63	34	-	-	-
1-B15	3.0	42	52	2	102	23
	6.0	58	51	2	101	21
	8.0	55	42	-	-	-
	10.5	73	49	2	103	25
	16.0	76	41	-	-	-
1-B16	3.0	28	36	2	96	0
	6.0	35	31	-	-	-
	8.0	51	39	-	-	-
	11.0	87	56	3	101	1
	16.0	88	47	8	100	0

TABLE 4						
SUMMARY OF LABORATORY TEST RESULTS						
Boring	Depth [ft]	N_{field}³ [b/ft]	N₁₍₆₀₎⁴ [b/ft]	Moisture Content [percent]	Dry Density [lb/ft³]	Percent Passing No. 200 Sieve [percent]
	21.0	55	26	-	-	-
	26.0	86	36	4	105	3
1-B17	3.0	82	92	7	122	13
	5.5	77	65	8	112	26
	8.0	42	30	-	-	-
	11.0	20	12	7	108	24
	16.0	37	19	-	-	-
	3.0	39	48	3	106	26
1-B18	5.5	36	33	1	98	2
	8.0	32	24	-	-	-
	11.0	24	16	1	103	3
	16.0	36	19	-	-	-
	3.0	25	31	4	105	10
1-B19	6.0	6	5	4	99	11
	8.0	33	25	-	-	-
	11.0	26	17	5	111	12
	16.0	57	30	-	-	-
	3.0	10	12	5	106	30
1-B20	6.0	26	22	7	110	31
	8.0	27	20	-	-	-
	11.0	47	29	4	107	24
	16.0	83	43	-	-	-
	3.0	33	40	3	108	36
1-B21	6.0	32	28	3	103	23
	8.0	36	27	-	-	-
	11.0	52	33	4	103	22
	16.0	53	28	-	-	-
	3.0	33	40	3	109	21
1-B22	6.0	35	30	3	105	25
	8.0	35	26	-	-	-
	11.0	41	26	-	-	-
	16.0	28	15	3	102	9
	2-TP1	2.5	-	-	7.1	-
6.0		-	-	4.4	-	3.5
2-TP2	2.5	-	-	9.3	-	4.4
	6.0	-	-	3.2	-	3.5
3-B1	3.0	53	107	5.3	-	8.3

TABLE 4 SUMMARY OF LABORATORY TEST RESULTS						
Boring	Depth [ft]	N _{field} ³ [b/ft]	N ₁₍₆₀₎ ⁴ [b/ft]	Moisture Content [percent]	Dry Density [lb/ft ³]	Percent Passing No. 200 Sieve [percent]
	6.0	8	11	5.7	-	14.3
	11.0	15	16	3.9	-	5.2
3-B2	3.0	11	22	4.4	-	6.0
	6.0	14	20	4.3	-	4.0
	11.0	20	21	4.3	-	5.6
3-B3	3.0	16	32	3.9	-	7.9
	6.0	21	30	5.9	-	9.1
	11.0	34	36	5.2	-	14.8
3-B4	3.0	18	36	1.9	-	16.9
	8.0	13	16	8.6	-	12.1
	11.0	30	32	4.9	-	4.1
3-B5	3.0	15	30	1.9	-	8.7
	6.0	17	24	1.5	-	7.9
	11.0	24	25	3.8	-	3.6

APPENDIX A

ENGEO, INCORPORATED

Boring Logs

DRAFT

KEY TO BORING LOGS

MAJOR TYPES

DESCRIPTION

COARSE-GRAINED SOILS MORE THAN HALF OF MAT'L LARGER THAN #200 SIEVE	GRAVELS MORE THAN HALF COARSE FRACTION IS LARGER THAN NO. 4 SIEVE SIZE	CLEAN GRAVELS WITH LITTLE OR NO FINES		GW - Well graded gravels or gravel-sand mixtures
		GRAVELS WITH OVER 12 % FINES		GP - Poorly graded gravels or gravel-sand mixtures
	SANDS MORE THAN HALF COARSE FRACTION IS SMALLER THAN NO. 4 SIEVE SIZE	CLEAN SANDS WITH LITTLE OR NO FINES		SW - Well graded sands, or gravelly sand mixtures
		SANDS WITH OVER 12 % FINES		SP - Poorly graded sands or gravelly sand mixtures
FINE-GRAINED SOILS MORE THAN HALF OF MAT'L SMALLER THAN #200 SIEVE	SILTS AND CLAYS LIQUID LIMIT 50 % OR LESS		ML - Inorganic silt with low to medium plasticity	
			CL - Inorganic clay with low to medium plasticity	
			OL - Low plasticity organic silts and clays	
	SILTS AND CLAYS LIQUID LIMIT GREATER THAN 50 %		MH - Inorganic silt with high plasticity	
			CH - Inorganic clay with high plasticity	
HIGHLY ORGANIC SOILS		OH - Highly plastic organic silts and clays		
			PT - Peat and other highly organic soils	

GRAIN SIZES

	U.S. STANDARD SERIES SIEVE SIZE				CLEAR SQUARE SIEVE OPENINGS			
	200	40	10	4	3/4 "	3"	12"	
SILTS AND CLAYS	SAND				GRAVEL		COBBLES	BOULDERS
	FINE	MEDIUM	COARSE	FINE	COARSE			

RELATIVE DENSITY

SANDS AND GRAVELS	BLOWS/FOOT (S.P.T.)
VERY LOOSE	0-4
LOOSE	4-10
MEDIUM DENSE	10-30
DENSE	30-50
VERY DENSE	OVER 50

CONSISTENCY

SILTS AND CLAYS	STRENGTH*	BLOWS/FOOT (S.P.T.)
VERY SOFT	0-1/4	0-2
SOFT	1/4-1/2	2-4
MEDIUM STIFF	1/2-1	4-8
STIFF	1-2	8-15
VERY STIFF	2-4	15-30
HARD	OVER 4	OVER 30

MOISTURE CONDITION

DRY	Absence of moisture, dusty, dry to touch
MOIST	Damp but no visible water
WET	Visible freewater
SATURATED	Below the water table

MINOR CONSTITUENT QUANTITIES (BY WEIGHT)

TRACE	Particles are present, but estimated to the less than 5%
SOME	5 to 15%
WITH	15 to 30%
.....Y	30 to 50%

SAMPLER SYMBOLS

	Modified California (3" O.D.) sampler
	California (2.5" O.D.) sampler
	S.P.T. - Split spoon sampler
	Shelby Tube
	Continuous Core
	Bag Samples
	Grab Samples
NR	No Recovery

LINE TYPES

—————	Solid - Layer Break
-----	Dashed - Gradational or approximate layer break

GROUND-WATER SYMBOLS

	Groundwater level during drilling
	Stabilized groundwater level

(S.P.T.) Number of blows of 140 lb. hammer falling 30" to drive a 2-inch O.D. (1-3/8 inch I.D.) sampler

* Unconfined compressive strength in tons/sq. ft., asterisk on log means determined by pocket penetrometer



LOG OF BORING 1-B1

Geotechnical Exploration
Marina Coast R/W 100%
Marina, CA
7496100101

DATE DRILLED: 10/27/2006
HOLE DEPTH (FT): Approx. 16 1/2 ft
HOLE DIAMETER: 4.0 in.
SURF ELEV (FT-MSL): 245 ft.

LOGGED / REVIEWED BY: D. WAHL/B.R.
DRILLING CONTRACTOR: Ram Geotechnical
DRILLING METHOD: Solid Flight Auger
HAMMER TYPE: 140 lb. Rope and Cathead

Depth in Feet	Depth in Meters	Sample Type	DESCRIPTION	Log Symbol	Water Level	Blow Count / Foot	Moisture Content (% dry weight)	Dry Unit Weight (pcf)	Percent Fines - #200
0	0		4" of Asphalt Concrete over 6" of Aggregate Base.						
			SAND with SILT (SW), light tan, dry, dense, fine to medium grained.			32	2.8	104	11.9
5			SAND (SP), light yellowish brown, moist, medium dense to dense, coarse grained.			24	2.0	102	2.6
10						28	2.8	102	2.2
15			Grades fine to medium grained.			55	3.4	103	2.8
16.5			Bottom of boring at approximately 16.5' below ground surface. No groundwater encountered.			46			
20									
25									
30									



LOG OF BORING 1-B4

Geotechnical Exploration
Marina Coast R/W 100%
Marina, CA
7496100101

DATE DRILLED: 10/30/2006
HOLE DEPTH (FT): Approx. 16 ft
HOLE DIAMETER: 4.0 in.
SURF ELEV (FT-MSL): 205 ft.

LOGGED / REVIEWED BY: P.NAJAR/B.R.
DRILLING CONTRACTOR: Ram Geotechnical
DRILLING METHOD: Solid Flight Auger
HAMMER TYPE: 140 lb. Rope and Cathead

Depth in Feet	Depth in Meters	Sample Type	DESCRIPTION	Log Symbol	Water Level	Blow Count / Foot	Moisture Content (% dry weight)	Dry Unit Weight (pcf)	Percent Fines - #200
0	0		4" of Asphalt Concrete over 5" of Aggregate Base.						
			SAND (SP), light brown, slightly moist, medium dense, fine to medium grained, well rounded.			27	4.5	103	16.3
5						43	6.0	104	3.8
10						30			
15						84	5.7	104	2.9
5			Bottom of boring at approximately 16.0' below ground surface. No groundwater encountered.						
20									
25									
30									

LOG OF BORING 1-B5

Geotechnical Exploration
Marina Coast R/W 100%
Marina, CA
7496100101

DATE DRILLED: 10/27/2006
HOLE DEPTH (FT): Approx. 16 1/2 ft.
HOLE DIAMETER: 4.0 in.
SURF ELEV (FT-MSL): 250 ft.

LOGGED / REVIEWED BY: D. WAHL/B.R.
DRILLING CONTRACTOR: Ram Geotechnical
DRILLING METHOD: Solid Flight Auger
HAMMER TYPE: 140 lb. Rope and Cathead

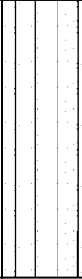
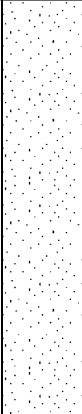
Depth in Feet	Depth in Meters	Sample Type	DESCRIPTION	Log Symbol	Water Level	Blow Count / Foot	Moisture Content (% dry weight)	Dry Unit Weight (pcf)	Percent Finer - #200
0	0		12 to 18 inches of Aggregate Base.						
			SAND with SILT (SW), brown to dark brown, dry to moist, medium dense, fine grained, some rootlets.			25	3.3	97	5.3
5						26	3.2	106	13.2
			SAND (SP), light yellowish brown, moist, medium dense to dense, fine to medium grained.			29	5.7	98	4.9
10						33	5.6	101	4.4
15						46	7.3	103	
			Bottom of boring at approximately 16.5' below ground surface. No groundwater encountered.						

LOG OF BORING 1-B6

Geotechnical Exploration
Marina Coast R/W 100%
MARINA, CA
7496100101

DATE DRILLED: 10/27/2006
HOLE DEPTH (FT): Approx. 16 1/2 ft.
HOLE DIAMETER: 4.0 in.
SURF ELEV (FT-MSL): 245 ft.

LOGGED / REVIEWED BY: D. WAHL/B.R.
DRILLING CONTRACTOR: Ram Geotechnical
DRILLING METHOD: Solid Flight Auger
HAMMER TYPE: 140 lb. Rope and Cathead

Depth in Feet	Depth in Meters	Sample Type	DESCRIPTION	Log Symbol	Water Level	Blow Count / Foot	Moisture Content (% dry weight)	Dry Unit Weight (pcf)	Percent Fines - #200
0	0		12 to 18 inches of Aggregate Base.						
0.5	0.15		SAND with SILT (SW), brown, moist, very dense, fine to medium grained, some organics, some oxidation, some clayey nodules.			50/6"	2.6	111	9.0
1.5	0.45		Light tan brown, slightly moist, dense, very fine grained.			40	3.2	107	15.6
2.5	0.75		SAND (SP), light yellowish brown, moist, medium dense to dense, fine to medium grained.			45	3.5	104	5.5
3.5	1.05					28	3.9	99	5.2
4.5	1.35								
5.5	1.65					47			
Bottom of boring at approximately 16.5' below ground surface. No groundwater encountered.									



LOG OF BORING 1-B7

Geotechnical Exploration
Marina Coast R/W 100%
Marina, CA
7496100101

DATE DRILLED: 10/31/2006
HOLE DEPTH (FT): Approx. 26 1/2 ft.
HOLE DIAMETER: 4.0 in.
SURF ELEV (FT-MSL): 200 ft.

LOGGED / REVIEWED BY: P.NAJAR/B.R.
DRILLING CONTRACTOR: Ram Geotechnical
DRILLING METHOD: Solid Flight Auger
HAMMER TYPE: 140 lb. Rope and Cathead

Depth in Feet	Depth in Meters	Sample Type	DESCRIPTION	Log Symbol	Water Level	Blow Count / Foot	Moisture Content (% dry weight)	Dry Unit Weight (pcf)	Percent Fines - #200
0	0		3" of Asphalt Concrete over 6" of Aggregate Base.						
			SAND (SP), light yellowish-brown damp, very dense, fine to medium grained, well rounded.			55	5.6	122	10.1
5						65	6.5	108	4.3
10						51			
15						40	5.3	101	2.5
20			SAND with SILT (SW), dark brown, very moist, medium dense, fine to medium grained, well rounded.			23			
25			SAND (SP), yellowish-brown, very moist, medium dense, fine to medium grained, well rounded.			18			
30						59	5.0	104	3.1
			Bottom of boring at approximately 26.5' below ground surface. No groundwater encountered.						



LOG OF BORING 1-B8

Geotechnical Exploration
Marina Coast R/W 100%
Marina, CA
7496100101

DATE DRILLED: 10/27/2006
HOLE DEPTH (FT): Approx. 16 1/2 ft.
HOLE DIAMETER: 4.0 in.
SURF ELEV (FT-MSL): 125 ft.

LOGGED / REVIEWED BY: D. WAHL/B.R.
DRILLING CONTRACTOR: Ram Geotechnical
DRILLING METHOD: Solid Flight Auger
HAMMER TYPE: 140 lb. Rope and Cathead

Depth in Feet	Depth in Meters	Sample Type	DESCRIPTION	Log Symbol	Water Level	Blow Count / Foot	Moisture Content (% dry weight)	Dry Unit Weight (pcf)	Percent Passing - #200
0	0		3" of Asphalt Concrete over 6" of Aggregate Base.						
			SAND with SILT (SW), brown to dark brown, moist, dense, gravel to 1" diameter.						
			SAND (SP), light yellowish brown, moist, dense, medium to coarse grained.			59	2.3	105	2.9
1									
5						39	2.2	103	1.9
2			Grades medium grained.						
						39	2.7	102	1.8
10									
3			Grades coarse grained.						
						42	2.2	104	1.5
15									
5						47	2.7	101	1.4
			Bottom of boring at approximately 16.5' below ground surface. No groundwater encountered.						
20	6								
25	8								
30	9								



LOG OF BORING 1-B9

Geotechnical Exploration
Marina Coast R/W 100%
Marina, CA
7496100101

DATE DRILLED: 10/27/2006
HOLE DEPTH (FT): Approx. 16 1/2 ft.
HOLE DIAMETER: 4.0 in.
SURF ELEV (FT-MSL): 130 ft.

LOGGED / REVIEWED BY: D. WAHL/B.R.
DRILLING CONTRACTOR: Ram Geotechnical
DRILLING METHOD: Solid Flight Auger
HAMMER TYPE: 140 lb. Rope and Cathead

Depth in Feet	Depth in Meters	Sample Type	DESCRIPTION	Log Symbol	Water Level	Blow Count / Foot	Moisture Content (% dry weight)	Dry Unit Weight (pcf)	Percent Fines - #200
0	0		3" of Asphalt Concrete over 6" of Aggregate Base.						
			SAND (SP), light yellowish tan, moist, dense, coarse grained.			47	1.6	106	0.9
1									
5						35	1.7	106	0.8
2									
			Grades medium grained.			48	1.9	106	0.9
10	3					60	2.3	103	2.3
4									
15						42			
5									
			Bottom of boring at approximately 16.5' below ground surface. No groundwater encountered.						
20	6								
7									
25									
8									
30	9								



LOG OF BORING 1-B10

Geotechnical Exploration
Marina Coast R/W 100%
Marina, CA
7496100101

DATE DRILLED: 10/27/2006
HOLE DEPTH (FT): Approx. 13 1/2 ft.
HOLE DIAMETER: 4.0 in.
SURF ELEV (FT-MSL): 195 ft.

LOGGED / REVIEWED BY: D. WAHL/B.R.
DRILLING CONTRACTOR: Ram Geotechnical
DRILLING METHOD: Solid Flight Auger
HAMMER TYPE: 140 lb. Rope and Cathead

Depth in Feet	Depth in Meters	Sample Type	DESCRIPTION	Log Symbol	Water Level	Blow Count / Foot	Moisture Content (% dry weight)	Dry Unit Weight (pcf)	Percent Fines - #200
0	0		2" of Asphalt Concrete over 4" of Aggregate Base.						
0	0		SAND (SP), light yellowish tan, moist, dense, coarse grained.						
1	0.3					44	5.2	110	10.1
5	1.5					16	5.2	106	10.5
2	0.6					25	3.1	102	1.1
			Grades medium grained.						
10	3.0								
4	1.2					51	2.9	104	1.8
15	4.5								
5	1.5								
			Bottom of boring at approximately 16.5' below ground surface. No groundwater encountered.						
20	6.0								
7	2.1								
25	7.6								
8	2.4								
30	9.1								



LOG OF BORING 1-B11

Geotechnical Exploration
Marina Coast R/W 100%
Marina, CA
7496100101

DATE DRILLED: 10/27/06
HOLE DEPTH (FT): Approx. 13 1/2 ft.
HOLE DIAMETER: 4.0 in.
SURF ELEV (FT-MSL): 165 ft.

LOGGED / REVIEWED BY: D. WAHL/B.R.
DRILLING CONTRACTOR: Ram Geotechnical
DRILLING METHOD: Solid Flight Auger
HAMMER TYPE: 140 lb. Rope and Cathead

Depth in Feet	Depth in Meters	Sample Type	DESCRIPTION	Log Symbol	Water Level	Blow Count / Foot	Moisture Content (% dry weight)	Dry Unit Weight (pcf)	Percent Fines - #200
0	0		2" of Asphalt Concrete over 8" of Aggregate Base.						
			SAND (SP), light yellowish tan, slightly moist, medium dense, fine grained.						
1						36	2.1	98	1.2
5						30	2.4	99	0.3
2						41	2.4	103	0.6
10	3								
4						64			
15									
5	5								
20	6		Bottom of boring at approximately 16.5' below ground surface. No groundwater encountered.						
7									
25									
8									
30	9								



LOG OF BORING 1-B12

Geotechnical Exploration
Marina Coast R/W 100%
Marina, CA
7496100101

DATE DRILLED: 10/30/2006
HOLE DEPTH (FT): Approx. 16 1/2 ft.
HOLE DIAMETER: 4.0 in.
SURF ELEV (FT-MSL): 120 ft.

LOGGED / REVIEWED BY: P.NAJAR/B.R.
DRILLING CONTRACTOR: Ram Geotechnical
DRILLING METHOD: Solid Flight Auger
HAMMER TYPE: 140 lb. Rope and Cathead

Depth in Feet	Depth in Meters	Sample Type	DESCRIPTION	Log Symbol	Water Level	Blow Count / Foot	Moisture Content (% dry weight)	Dry Unit Weight (pcf)	Percent Fines - #200
0	0		3" of Asphalt Concrete over 4" of Aggregate Base.						
1	0.3		SAND (SP), light yellowish-brown, slightly moist, medium dense, fine to medium grained, well rounded.			17	2.6	101	2.0
5	1.5				32	2.8	104	1.6	
10	3.0				45				
15	4.5				72	2.6	103	1.7	
16.5	5.0		Bottom of boring at approximately 16.5' below ground surface. No groundwater encountered.			79			
20	6.0								
25	7.5								
30	9.0								



LOG OF BORING 1-B13

Geotechnical Exploration
Marina Coast R/W 100%
Marina, CA
7496100101

DATE DRILLED: 10/30/2006
HOLE DEPTH (FT): Approx. 13 1/2 ft.
HOLE DIAMETER: 4.0 in.
SURF ELEV (FT-MSL): 100 ft.

LOGGED / REVIEWED BY: P.NAJAR/B.R
DRILLING CONTRACTOR: Ram Geotechnical
DRILLING METHOD: Solid Flight Auger
HAMMER TYPE: 140 lb. Rope and Cathead

Depth in Feet	Depth in Meters	Sample Type	DESCRIPTION	Log Symbol	Water Level	Blow Count / Foot	Moisture Content (% dry weight)	Dry Unit Weight (pcf)	Percent Fines - #200
0	0		5" of Asphalt Concrete over 6" of Aggregate Base.						
0	0		SAND (SP), light yellowish-brown, slightly moist, very dense, fine to medium grained, well rounded.			60	1.8	104	0.6
1	0.3								
5	1.5					39			
2	0.6		Grades fine to course grained.			62	2.6	105	2.2
3	0.9					59	2.4	103	1.1
4	1.2								
15	4.6					80			
5	1.5		Bottom of boring at approximately 16.5' below ground surface. No groundwater encountered.						
6	1.8								
7	2.1								
25	7.6								
8	2.4								
9	2.7								
30	9.1								



LOG OF BORING 1-B14

Geotechnical Exploration
Marina Coast R/W 100%
Marina, CA
7496100101

DATE DRILLED: 10/30/2006
HOLE DEPTH (FT): Approx. 16 1/2 ft.
HOLE DIAMETER: 4.0 in.
SURF ELEV (FT-MSL): 125 ft.

LOGGED / REVIEWED BY: P.NAJAR/B.R.
DRILLING CONTRACTOR: Ram Geotechnical
DRILLING METHOD: Solid Flight Auger
HAMMER TYPE: 140 lb. Rope and Cathead

Depth in Feet	Depth in Meters	Sample Type	DESCRIPTION	Log Symbol	Water Level	Blow Count / Foot	Moisture Content (% dry weight)	Dry Unit Weight (pcf)	Percent Fines - #200
0	0		5" of Asphalt Concrete over 6" of Aggregate Base.						
			SAND (SP), dark yellowish-brown, slightly moist, medium dense, fine to medium grained, well rounded.			25	4.0	105	4.4
1									
5						38	1.5	99	0.8
2						70			
10	3					59	1.8	102	2.9
15	4					63			
5	5								
			Bottom of boring at approximately 16.5' below ground surface. No groundwater encountered.						
20	6								
25	7								
30	8								
	9								



LOG OF BORING 1-B15

Geotechnical Exploration
Marina Coast R/W 100%
Marina, CA
7496100101

DATE DRILLED: 10/30/2006
HOLE DEPTH (FT): Approx. 16 1/2 ft.
HOLE DIAMETER: 4.0 in.
SURF ELEV (FT-MSL): 75 ft.

LOGGED / REVIEWED BY: P.NAJAR/B.R.
DRILLING CONTRACTOR: Ram Geotechnical
DRILLING METHOD: Solid Flight Auger
HAMMER TYPE: 140 lb. Rope and Cathead

Depth in Feet	Depth in Meters	Sample Type	DESCRIPTION	Log Symbol	Water Level	Blow Count / Foot	Moisture Content (% dry weight)	Dry Unit Weight (pcf)	Percent Fines - #200
0	0		9" Asphalt						
			4" of Aggregate Base.						
			SILTY SAND (SM), pale yellow, moist, dense, fine to medium grained, well rounded sand, some gravel to 1/4" diameter, well rounded gravel.			42	1.9	102	23.1
5						58	1.7	101	21.2
10						55			
15						73	2.4	103	25.2
16.5			Bottom of boring at approximately 16.5' below ground surface. No groundwater encountered.			76			



LOG OF BORING 1-B16

Geotechnical Exploration
Marina Coast R/W 100%
Marina, CA
7496100101

DATE DRILLED: 11/3/2006
HOLE DEPTH (FT): Approx. 31 1/2 ft.
HOLE DIAMETER: 4.0 in.
SURF ELEV (FT-MSL): 70 ft.

LOGGED / REVIEWED BY: P.Najar/B.R.
DRILLING CONTRACTOR: Ram Geotechnical
DRILLING METHOD: Solid Flight Auger
HAMMER TYPE: 140 lb. Rope and Cathead

Depth in Feet	Depth in Meters	Sample Type	DESCRIPTION	Log Symbol	Water Level	Blow Count / Foot	Moisture Content (% dry weight)	Dry Unit Weight (pcf)	Percent Fines - #200
0	0		2" of Asphalt Concrete over 6" of Aggregate Base.						
1	0.3		SAND (SP), light yellowish-brown, damp, dense, fine to medium grained, well rounded sand.			28	1.9	96	0.3
5	1.5				35				
10	3.0				51				
15	4.5				87	2.8	101	1.4	
20	6.0		Grades fine to course grained, moist.			88	7.7	100	0.0
25	7.5				55				
30	9.0				86	4.0	105	2.7	
31.5	9.3		Bottom of boring at approximately 31.5' below ground surface. No groundwater encountered.			70			



LOG OF BORING 1-B17

Geotechnical Exploration
Marina Coast R/W 100%
Marina, CA
7496100101

DATE DRILLED: 10/30/2006
HOLE DEPTH (FT): Approx. 16 1/2 ft.
HOLE DIAMETER: 4.0 in.
SURF ELEV (FT-MSL): 105 ft.

LOGGED / REVIEWED BY: P.NAJAR/B.R.
DRILLING CONTRACTOR: Ram Geotechnical
DRILLING METHOD: Solid Flight Auger
HAMMER TYPE: 140 lb. Rope and Cathead

Depth in Feet	Depth in Meters	Sample Type	DESCRIPTION	Log Symbol	Water Level	Blow Count / Foot	Moisture Content (% dry weight)	Dry Unit Weight (pcf)	Percent Fines - #200
0	0		3" Asphalt						
			4" of Aggregate Base.						
			SAND (SP), dark yellowish-brown, moist, very dense, fine to medium grained, well rounded sand, trace silt.			82	7.1	122	13.0
5			Grades some silt, dark brown.						
			SILTY SAND (SM), dark brown, moist, dense, fine to medium grained, well rounded.			77	7.8	112	25.9
						42			
10									
			SAND (SP), dark yellowish-brown, moist, medium dense, fine to medium grained, well rounded, trace silt.			20	6.8	108	24.2
15			Becomes light yellowish-brown.						
						37			
			Bottom of boring at approximately 16.5' below ground surface. No groundwater encountered.						
20									
25									
30									

LOG OF BORING 1-B18

Geotechnical Exploration
Marina Coast R/W 100%
Marina, CA
7496100101

DATE DRILLED: 10/30/2006
HOLE DEPTH (FT): Approx. 16 1/2 ft.
HOLE DIAMETER: 4.0 in.
SURF ELEV (FT-MSL): 95 ft.

LOGGED / REVIEWED BY: P.NAJAR/B.R.
DRILLING CONTRACTOR: Ram Geotechnical
DRILLING METHOD: Solid Flight Auger
HAMMER TYPE: 140 lb. Rope and Cathead

Depth in Feet	Depth in Meters	Sample Type	DESCRIPTION	Log Symbol	Water Level	Blow Count / Foot	Moisture Content (% dry weight)	Dry Unit Weight (pcf)	Percent Fines - #200
0	0		3" Asphalt						
			4" of Aggregate Base.						
			SILTY SAND (SM), light yellowish-brown, moist, dense, fine to medium grained, well rounded.			39	2.5	106	26.0
5			SAND (SP), light yellowish-brown, moist, dense, fine to medium grained, well rounded.			36	1.4	98	1.7
10						32			
15						24	1.3	103	3.2
16.5			Bottom of boring at approximately 16.5' below ground surface. No groundwater encountered.			36			



LOG OF BORING 1-B19

Geotechnical Exploration
Marina Coast R/W 100%
Marina, CA
7496100101

DATE DRILLED: 10/30/2006
HOLE DEPTH (FT): Approx. 16 1/2 ft.
HOLE DIAMETER: 4.0 in.
SURF ELEV (FT-MSL): 80 ft.

LOGGED / REVIEWED BY: P.NAJAR/B.R.
DRILLING CONTRACTOR: Ram Geotechnical
DRILLING METHOD: Solid Flight Auger
HAMMER TYPE: 140 lb. Rope and Cathead

Depth in Feet	Depth in Meters	Sample Type	DESCRIPTION	Log Symbol	Water Level	Blow Count / Foot	Moisture Content (% dry weight)	Dry Unit Weight (pcf)	Percent Fines - #200
0	0		3" Asphalt 4" of Aggregate Base.						
1	0.3		SAND with SILT (SW), dark brown, moist, loose to medium dense, fine to medium grained, well rounded.			25	3.6	105	10.2
2	0.6					6	4.0	99	10.8
3	0.9		SAND (SP), dark yellowish-brown, moist, medium dense, fine to medium grained, well rounded, some silt.			33			
4	1.2					26	4.8	111	11.5
5	1.5					57			
Bottom of boring at approximately 16.5' below ground surface. No groundwater encountered.									



LOG OF BORING 1-B20

Geotechnical Exploration
Marina Coast R/W 100%
Marina, CA
7496100101

DATE DRILLED: 10/31/2006
HOLE DEPTH (FT): Approx. 16 ft.
HOLE DIAMETER: 4.0 in.
SURF ELEV (FT-MSL): 115 ft.

LOGGED / REVIEWED BY: P.Najar/B.R.
DRILLING CONTRACTOR: Ram Geotechnical
DRILLING METHOD: Solid Flight Auger
HAMMER TYPE: 140 lb. Rope and Cathead

Depth in Feet	Depth in Meters	Sample Type	DESCRIPTION	Log Symbol	Water Level	Blow Count / Foot	Moisture Content (% dry weight)	Dry Unit Weight (pcf)	Percent Fines - #200
0	0		Grassy surface						
			SILTY SAND (SM), dark yellowish-brown, loose, slightly moist, fine to medium grained, well rounded.						
			Becomes reddish-yellow, loose, slightly moist, fine to medium grained, well-rounded.			10	4.5	106	29.5
5						26	6.9	110	30.9
						27			
10						47	4.0	107	24.1
15						83			
			Bottom of boring at approximately 16.0' below ground surface. No groundwater encountered.						
20									
25									
30									



LOG OF BORING 1-B21

Geotechnical Exploration
Marina Coast R/W 100%
Marina, CA
7496100101

DATE DRILLED: 10/31/2006
HOLE DEPTH (FT): Approx. 16 1/2 ft.
HOLE DIAMETER: 4.0 in.
SURF ELEV (FT-MSL): 110 ft.

LOGGED / REVIEWED BY: P.Najar/B.R.
DRILLING CONTRACTOR: Ram Geotechnical
DRILLING METHOD: Solid Flight Auger
HAMMER TYPE: 140 lb. Rope and Cathead

Depth in Feet	Depth in Meters	Sample Type	DESCRIPTION	Log Symbol	Water Level	Blow Count / Foot	Moisture Content (% dry weight)	Dry Unit Weight (pcf)	Percent Fines - #200
0	0		Grassy surface SILTY SAND (SM), light yellowish-brown, slightly moist, medium dense, fine to medium grained, well rounded.			33	3.2	108	36.0
1						32	3.0	103	22.9
5						36			
10	3		Grades dense.			52	4.1	103	22.0
15						53			
			Bottom of boring at approximately 16.5' below ground surface. No groundwater encountered.						
20	6								
25									
30	9								



LOG OF BORING 1-B22

Geotechnical Exploration
Marina Coast R/W 100%
Marina, CA
7496100101

DATE DRILLED: 11/3/2006
HOLE DEPTH (FT): Approx. 16 1/2 ft.
HOLE DIAMETER: 4.0 in.
SURF ELEV (FT-MSL): 130 ft.

LOGGED / REVIEWED BY: P.Najar/B.R
DRILLING CONTRACTOR: Ram Geotechnical
DRILLING METHOD: Solid Flight Auger
HAMMER TYPE: 140 lb. Rope and Cathead

Depth in Feet	Depth in Meters	Sample Type	DESCRIPTION	Log Symbol	Water Level	Blow Count / Foot	Moisture Content (% dry weight)	Dry Unit Weight (pcf)	Percent Fines - #200
0	0		3" of Asphalt Concrete over 6" of Aggregate Base.						
			SILTY SAND (SM), olive-brown, slightly moist, medium dense, fine to medium grained, well rounded.			33	3.1	109	20.6
1									
5			Becomes dark yellowish brown.			35	2.9	105	25.0
2									
			SAND (SP), light yellowish-brown, slightly damp, medium dense, fine to medium grained, well rounded.			35			
10	3					41			
15			Becomes dark yellowish-brown.			28	2.5	102	9.0
5									
			Bottom of boring at approximately 16.5' below ground surface. No groundwater encountered.						
20	6								
25									
30	9								



LOG OF BORING 3-B1

Geotechnical Exploration
Marina Coast R/W 100%
Marina, CA
7496100301

DATE DRILLED: 7/23/2007
HOLE DEPTH: Approx. 16½ ft.
HOLE DIAMETER: 4.0 in.
SURF ELEV (FT-MSL): Approx. 141 ft.

LOGGED / REVIEWED BY: A. Schuetze /
DRILLING CONTRACTOR: Ram Geotechnical
DRILLING METHOD: Solid Flight Auger
HAMMER TYPE: 140 lb. Rope and Cathead

Depth in Feet	Depth in Meters	Sample Type	DESCRIPTION	Log Symbol	Water Level	Blow Count/Foot	Atterberg Limits			Fines Content (% passing #200 sieve)	Moisture Content (% dry weight)	Dry Unit Weight (pcf)	Unconfined Strength (tsf) *field approx
							Liquid Limit	Plastic Limit	Plasticity Index				
			Pavement Surface										
			AGGREGATE BASE (AB)										
			WELL GRADED SAND (SW), yellowish brown, very dense, moist, some silt, trace gravel			59				8	5.3		
1													
	5		WELL GRADED SAND (SW), dark yellowish brown, loose, moist, some silt, trace gravel, trace coarse-grained sand			8				14	5.7		
2													
			WELL GRADED SAND (SW), yellowish red, loose, moist, some silt, trace gravel			7							
10			WELL GRADED SAND (SW), reddish yellow, medium dense, moist, with silt			15				5	3.9		
4													
	15		WELL GRADED SAND (SW), reddish yellow, medium dense, moist, with silt, Bottom of boring at 16.5'. GW not encountered during drilling.			30							
5													
			Bottom of boring at 16.5'. GW not encountered during drilling.										



LOG OF BORING 3-B2

Geotechnical Exploration
Marina Coast R/W 100%
Marina, CA
7496100301

DATE DRILLED: 7/23/2007
HOLE DEPTH: Approx. 16½ ft.
HOLE DIAMETER: 4.0 in.
SURF ELEV (FT-MSL): Approx. 148 ft.

LOGGED / REVIEWED BY: A. Schuetze /
DRILLING CONTRACTOR: Ram Geotechnical
DRILLING METHOD: Solid Flight Auger
HAMMER TYPE: 140 lb. Rope and Cathead

Depth in Feet	Depth in Meters	Sample Type	DESCRIPTION	Log Symbol	Water Level	Blow Count/Foot	Atterberg Limits			Fines Content (% passing #200 sieve)	Moisture Content (% dry weight)	Dry Unit Weight (pcf)	Unconfined Strength (tsf) *field approx
							Liquid Limit	Plastic Limit	Plasticity Index				
1			WELL GRADED SAND (SW), dark yellowish brown, medium dense, moist, some silt			11				6	4.4		
5			WELL GRADED SAND (SW), reddish yellow, medium dense, moist, some silt			14				4	4.3		
2			Lighter yellow-brown lens										
			WELL GRADED SAND (SW), light yellow, medium dense, moist, some silt alternating dark-to-light brown fine sands alternating dark-to-light brown fine sands			16							
10			WELL GRADED SAND (SW), reddish yellow, medium dense, moist, some silt			20				6	4.3		
15			WELL GRADED SAND (SW), reddish yellow, dense, moist, some silt, Bottom of boring at 16.5'. GW not encountered during drilling.			36							
5			Bottom of boring at 16.5'. GW not encountered during drilling.										



LOG OF BORING 3-B3

Geotechnical Exploration
Marina Coast R/W 100%
Marina, CA
7496100301

DATE DRILLED: 7/23/2007
HOLE DEPTH: Approx. 16½ ft.
HOLE DIAMETER: 4.0 in.
SURF ELEV (FT-MSL): Approx. 129 ft.

LOGGED / REVIEWED BY: A. Schuetze /
DRILLING CONTRACTOR: Ram Geotechnical
DRILLING METHOD: Solid Flight Auger
HAMMER TYPE: 140 lb. Rope and Cathead

Depth in Feet	Depth in Meters	Sample Type	DESCRIPTION	Log Symbol	Water Level	Blow Count/Foot	Atterberg Limits			Fines Content (% passing #200 sieve)	Moisture Content (% dry weight)	Dry Unit Weight (pcf)	Unconfined Strength (tsf) *field approx
							Liquid Limit	Plastic Limit	Plasticity Index				
1			WELL GRADED SAND (SW), dark yellowish brown, medium dense, moist, some silt			16				8	3.9		
5			WELL GRADED SAND (SW), yellowish red, medium dense, moist, some silt			21				9	5.9		
10			light yellowish red fine grained sand lens. Approx. 1/4".			25							
			WELL GRADED SAND (SW), yellowish red, dense, moist, some silt			34				15	5.2		
15			WELL GRADED SAND (SW), yellowish red, dense, moist, some silt, Bottom of boring at 16.5'. GW not encountered during drilling.			42							
5			Bottom of boring at 16.5'. GW not encountered during drilling.										



LOG OF BORING 3-B4

Geotechnical Exploration
Marina Coast R/W 100%
Marina, CA
7496100301

DATE DRILLED: 7/23/2007
HOLE DEPTH: Approx. 16½ ft.
HOLE DIAMETER: 4.0 in.
SURF ELEV (FT-MSL): Approx. 330 ft.

LOGGED / REVIEWED BY: A. Schuetze /
DRILLING CONTRACTOR: Ram Geotechnical
DRILLING METHOD: Solid Flight Auger
HAMMER TYPE: 140 lb. Rope and Cathead

Depth in Feet	Depth in Meters	Sample Type	DESCRIPTION	Log Symbol	Water Level	Blow Count/Foot	Atterberg Limits			Fines Content (% passing #200 sieve)	Moisture Content (% dry weight)	Dry Unit Weight (pcf)	Unconfined Strength (tsf) *field approx
							Liquid Limit	Plastic Limit	Plasticity Index				
1			WELL GRADED SAND (SW), yellowish brown, medium dense, moist, some silt, trace roots			18				17	1.9		
5			WELL GRADED SAND (SW), light yellowish, medium dense, moist, some silt			15							
2			WELL GRADED SAND (SW), reddish yellow, medium dense, moist, some silt			13				12	8.6		
10			WELL GRADED SAND (SW), light yellowish brown, medium dense, moist, some silt, Bottom of boring at 16.5'. GW not encountered during drilling.			30				4	4.9		
4													
15						47							
5			Bottom of boring at 16.5'. GW not encountered during drilling.										



LOG OF BORING 3-B5

Geotechnical Exploration
Marina Coast R/W 100%
Marina, CA
7496100301

DATE DRILLED: 7/23/2007
HOLE DEPTH: Approx. 16½ ft.
HOLE DIAMETER: 3.0 in.
SURF ELEV (FT-MSL): Approx. 380 ft.

LOGGED / REVIEWED BY: A. Schuetze /
DRILLING CONTRACTOR: Ram Geotechnical
DRILLING METHOD: Solid Flight Auger
HAMMER TYPE: 70 lb. Rope and Cathead

Depth in Feet	Depth in Meters	Sample Type	DESCRIPTION	Log Symbol	Water Level	Blow Count/Foot	Atterberg Limits			Fines Content (% passing #200 sieve)	Moisture Content (% dry weight)	Dry Unit Weight (pcf)	Unconfined Strength (tsf) *field approx
							Liquid Limit	Plastic Limit	Plasticity Index				
			Asphalt										
			WELL GRADED SAND (SW), dark brown, medium dense, dry to moist, with silt, trace roots			15				9	1.9		
1													
5			WELL GRADED SAND (SW), light yellowish brown, medium dense, dry to moist, some silt			17				8	1.5		
2													
			WELL GRADED SAND (SW), reddish yellow, medium dense, moist, some silt, reddish-brown clay lenses			16							
10													
			WELL GRADED SAND (SW), yellowish brown, medium dense, moist, some silt			24				4	3.8		
4													
15			WELL GRADED SAND (SW), yellowish brown, medium dense, moist, some silt, Bottom of boring at 16.5'. GW not encountered during drilling.			15							
5													
			Bottom of boring at 16.5'. GW not encountered during drilling.										

DRAFT

2-TP1

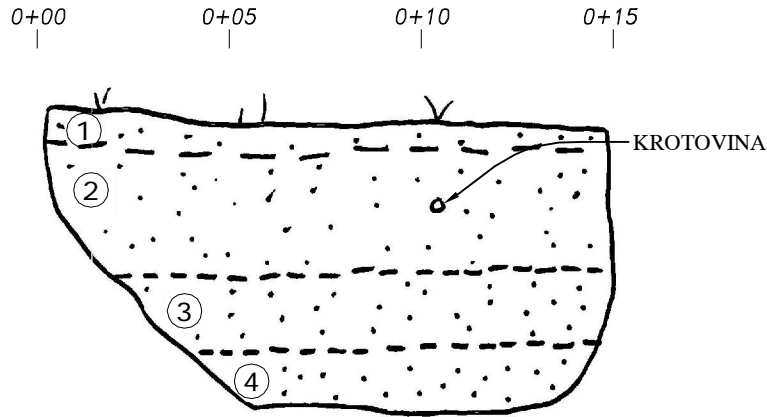

- ① Sand (SW), dark brown, loose, slightly moist, trace silt, fine to medium grained sand, trace rootlets
- ② Sand (SW), dark reddish brown, loose moist, trace silt, fine to medium grained sand
- ③ Sand (SW), dark yellowish brown, loose, very moist, fine to coarse-grained sand
- ④ Sand (SW), reddish yellow, loose, very moist, fine to coarse-grained sand

2-TP2

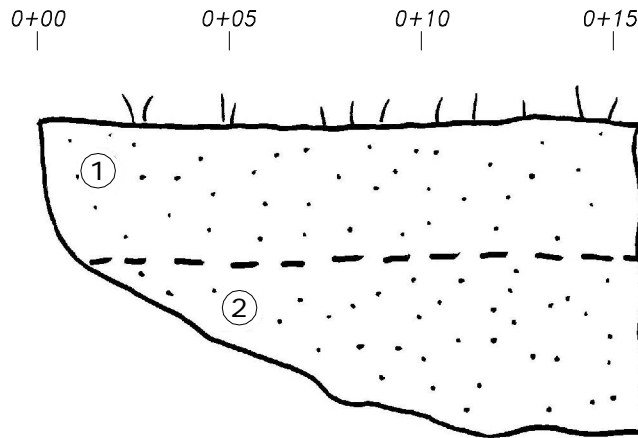

- ① Silty SAND (SM), very dark brown, loose to medium dense, dry, fine to medium-grained sand, trace rootlets
- ② Sand (SW), dark reddish brown, medium dense to dense, dry, fine to medium-grained sand with silt, trace rootlets

DRAFT

1"=5'



TEST PIT LOGS
MARINA COAST WATER DISTRICT
MARINA, CALIFORNIA

PROJECT NO.: 7496.1.001.01

DATE: AUGUST 2007

DRAWN BY: SRP

CHECKED BY:

FIGURE NO.
A1

APPENDIX B

ENGEO, INCORPORATED

Laboratory Test Data

DRAFT

Particle Size Distribution Report

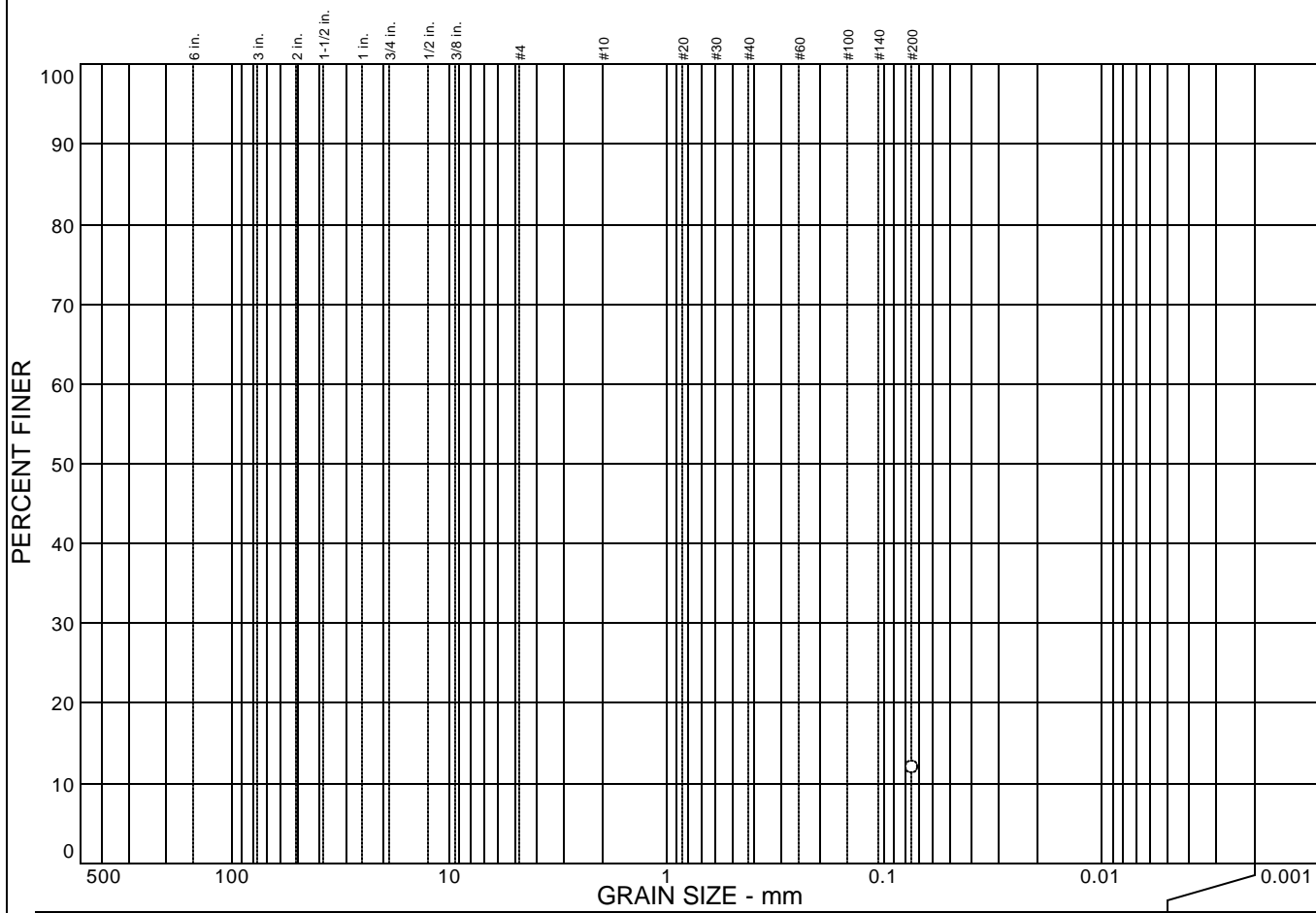

% COBBLES	% GRAVEL	% SAND	% SILT	% CLAY
			11.9	

SIEVE SIZE	PERCENT FINER	SPEC.* PERCENT	PASS? (X=NO)
#200	11.9		

Soil Description

Brownish yellow SAND with some silt.

Atterberg Limits

PL= LL= PI=

Coefficients

D₈₅= D₆₀= D₅₀=
D₃₀= D₁₅= D₁₀=
C_u= C_c=

Classification

USCS= AASHTO=

Remarks

* (no specification provided)

Sample No.: B1 @ 2.5'
Location:

Source of Sample:

Date: 11/08/06
Elev./Depth: 2.5 feet



Client:
Project: Marina Coast Recycled Water Pipeline - Marina, CA

Project No.: 7496.1.001.01

Particle Size Distribution Report

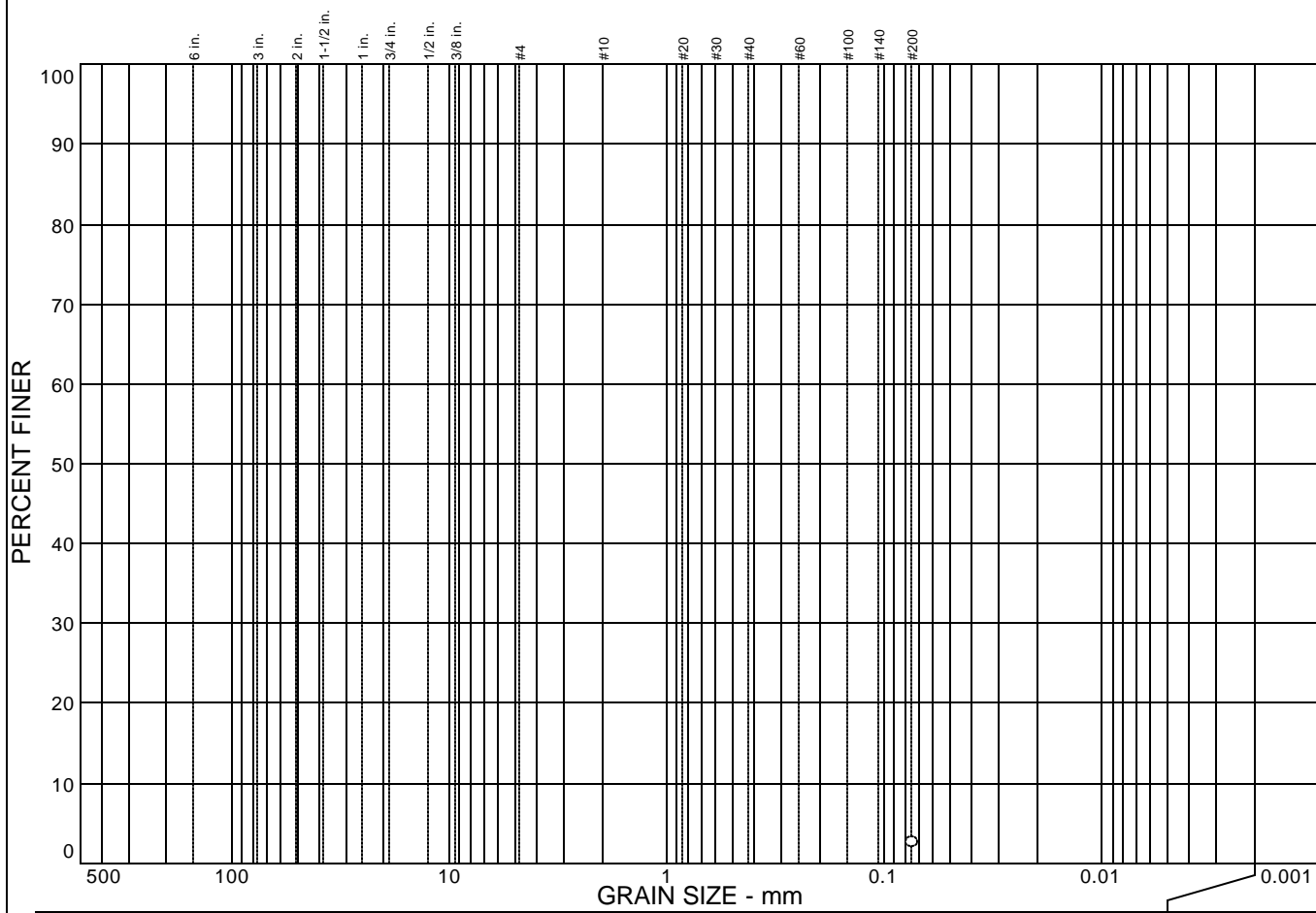

% COBBLES	% GRAVEL	% SAND	% SILT	% CLAY
			2.6	

SIEVE SIZE	PERCENT FINER	SPEC.* PERCENT	PASS? (X=NO)
#200	2.6		

Soil Description

Olive yellow SAND. Trace silt.

Atterberg Limits

PL= LL= PI=

Coefficients

D₈₅= D₆₀= D₅₀=
D₃₀= D₁₅= D₁₀=
C_u= C_c=

Classification

USCS= AASHTO=

Remarks

* (no specification provided)

Sample No.: B1 @ 6.0'
Location:

Source of Sample:

Date: 11/08/06
Elev./Depth: 6.0 feet



Client:
Project: Marina Coast Recycled Water Pipeline - Marina, CA

Project No.: 7496.1.001.01

Particle Size Distribution Report

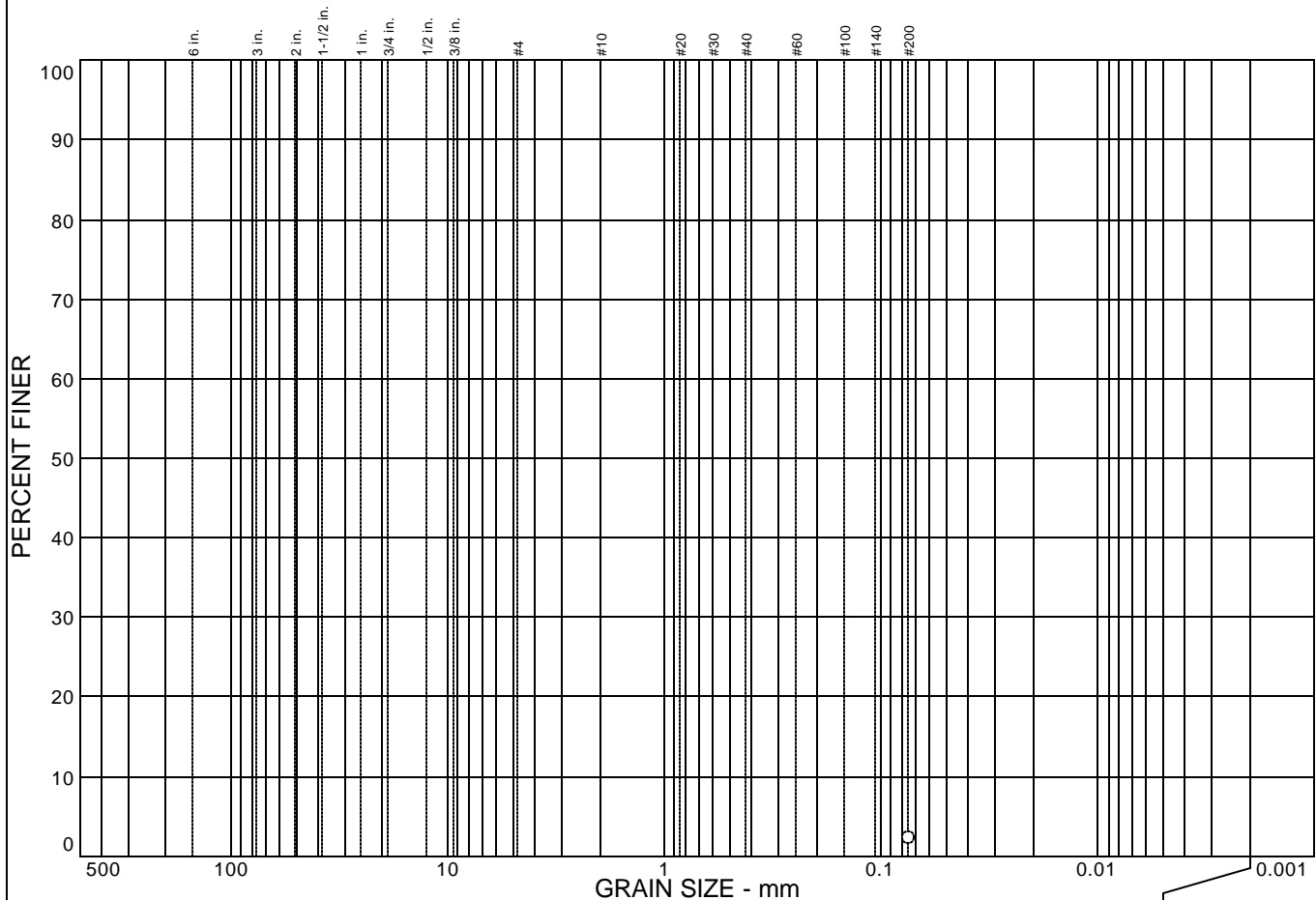

% COBBLES	% GRAVEL	% SAND	% SILT	% CLAY
			2.2	

SIEVE SIZE	PERCENT FINER	SPEC.* PERCENT	PASS? (X=NO)
#200	2.2		

Soil Description

Olive yellow SAND. Trace silt.

Atterberg Limits

PL= LL= PI=

Coefficients

D₈₅= D₆₀= D₅₀=
 D₃₀= D₁₅= D₁₀=
 C_u= C_c=

Classification

USCS= AASHTO=

Remarks

* (no specification provided)

Sample No.: B1 @ 8.0'
Location:

Source of Sample:

Date: 11/08/06
Elev./Depth: 8.0 feet



Client:
Project: Marina Coast Recycled Water Pipeline - Marina, CA

Project No.: 7496.1.001.01

Particle Size Distribution Report

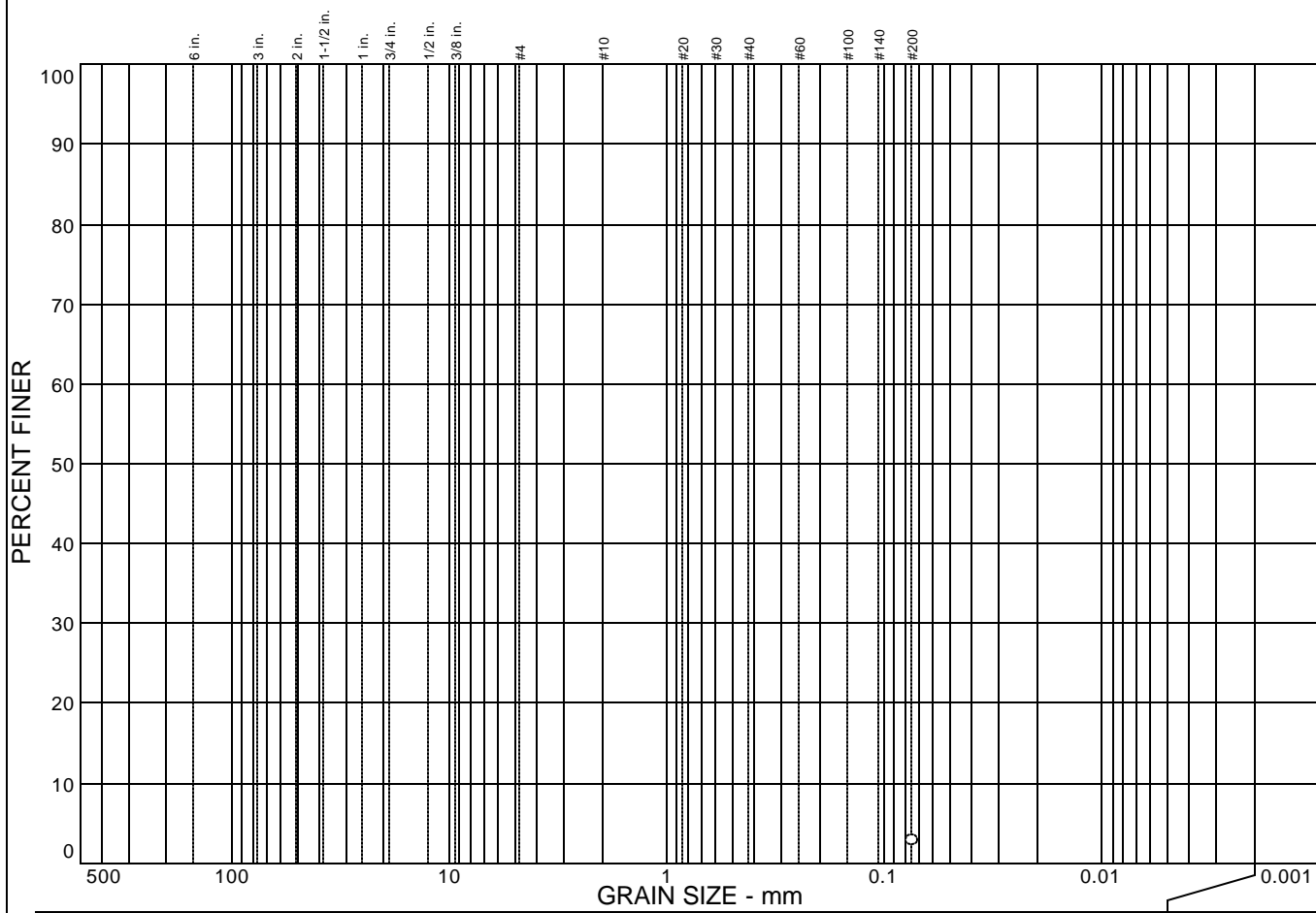

% COBBLES	% GRAVEL	% SAND	% SILT	% CLAY
			2.8	

SIEVE SIZE	PERCENT FINER	SPEC.* PERCENT	PASS? (X=NO)
#200	2.8		

Soil Description

Olive yellow SAND. Trace silt.

Atterberg Limits

PL= LL= PI=

Coefficients

D₈₅= D₆₀= D₅₀=
D₃₀= D₁₅= D₁₀=
C_u= C_c=

Classification

USCS= AASHTO=

Remarks

* (no specification provided)

Sample No.: B1 @ 11.0'
Location:

Source of Sample:

Date: 11/08/06
Elev./Depth: 11.0 feet



Client:
Project: Marina Coast Recycled Water Pipeline - Marina, CA

Project No.: 7496.1.001.01

Particle Size Distribution Report

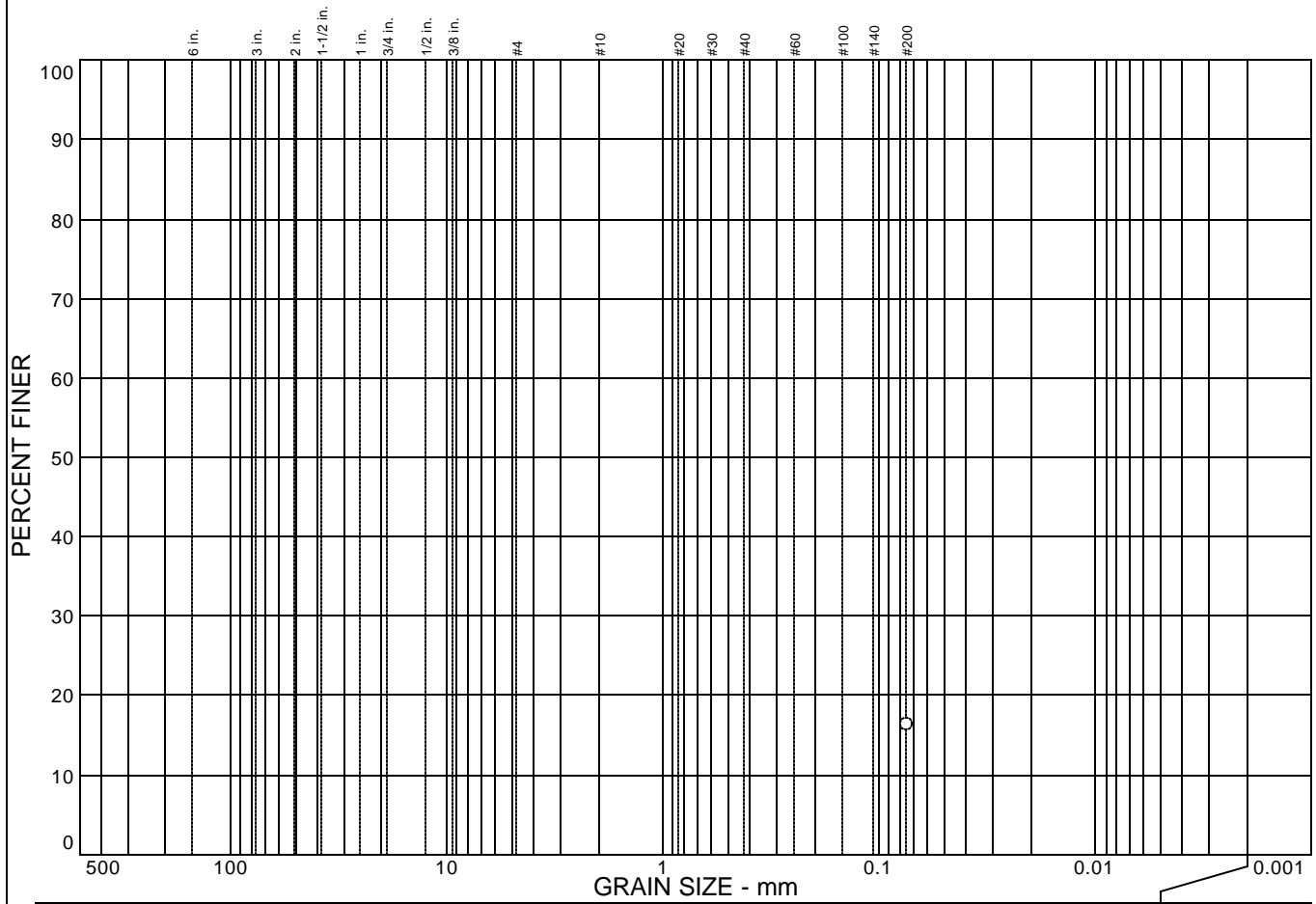

% COBBLES	% GRAVEL	% SAND	% SILT	% CLAY
			16.3	

SIEVE SIZE	PERCENT FINER	SPEC.* PERCENT	PASS? (X=NO)
#200	16.3		

Soil Description

Mix of dark brown and yellowish brown SAND with silt.

Atterberg Limits

PL= LL= PI=

Coefficients

D₈₅= D₆₀= D₅₀=
D₃₀= D₁₅= D₁₀=
C_u= C_c=

Classification

USCS= AASHTO=

Remarks

* (no specification provided)

Sample No.: B4 @ 3.0'
Location:

Source of Sample:

Date: 11/09/06
Elev./Depth: 3.0 feet



Client:
Project: Marina Coast Recycled Water Pipeline - Marina, CA

Project No.: 7496.1.001.01

Particle Size Distribution Report

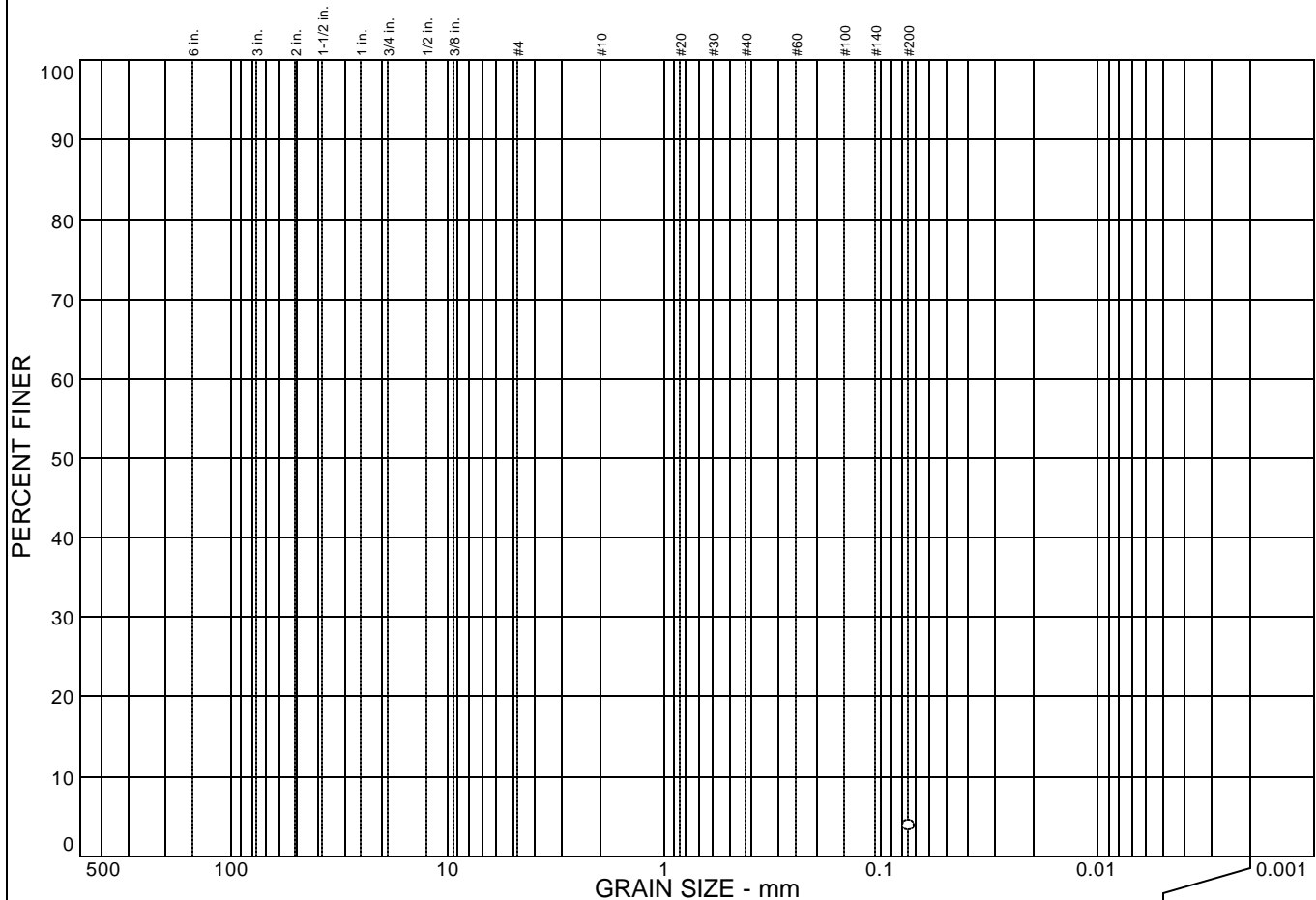

% COBBLES	% GRAVEL	% SAND	% SILT	% CLAY
			3.8	

SIEVE SIZE	PERCENT FINER	SPEC.* PERCENT	PASS? (X=NO)
#200	3.8		

Soil Description

Light yellowish brown SAND. Trace silt.

Atterberg Limits

PL= LL= PI=

Coefficients

D₈₅= D₆₀= D₅₀=
 D₃₀= D₁₅= D₁₀=
 C_u= C_c=

Classification

USCS= AASHTO=

Remarks

* (no specification provided)

Sample No.: B4 @ 6.0'
Location:

Source of Sample:

Date: 11/09/06
Elev./Depth: 6.0 feet



Client:
Project: Marina Coast Recycled Water Pipeline - Marina, CA

Project No.: 7496.1.001.01

Particle Size Distribution Report

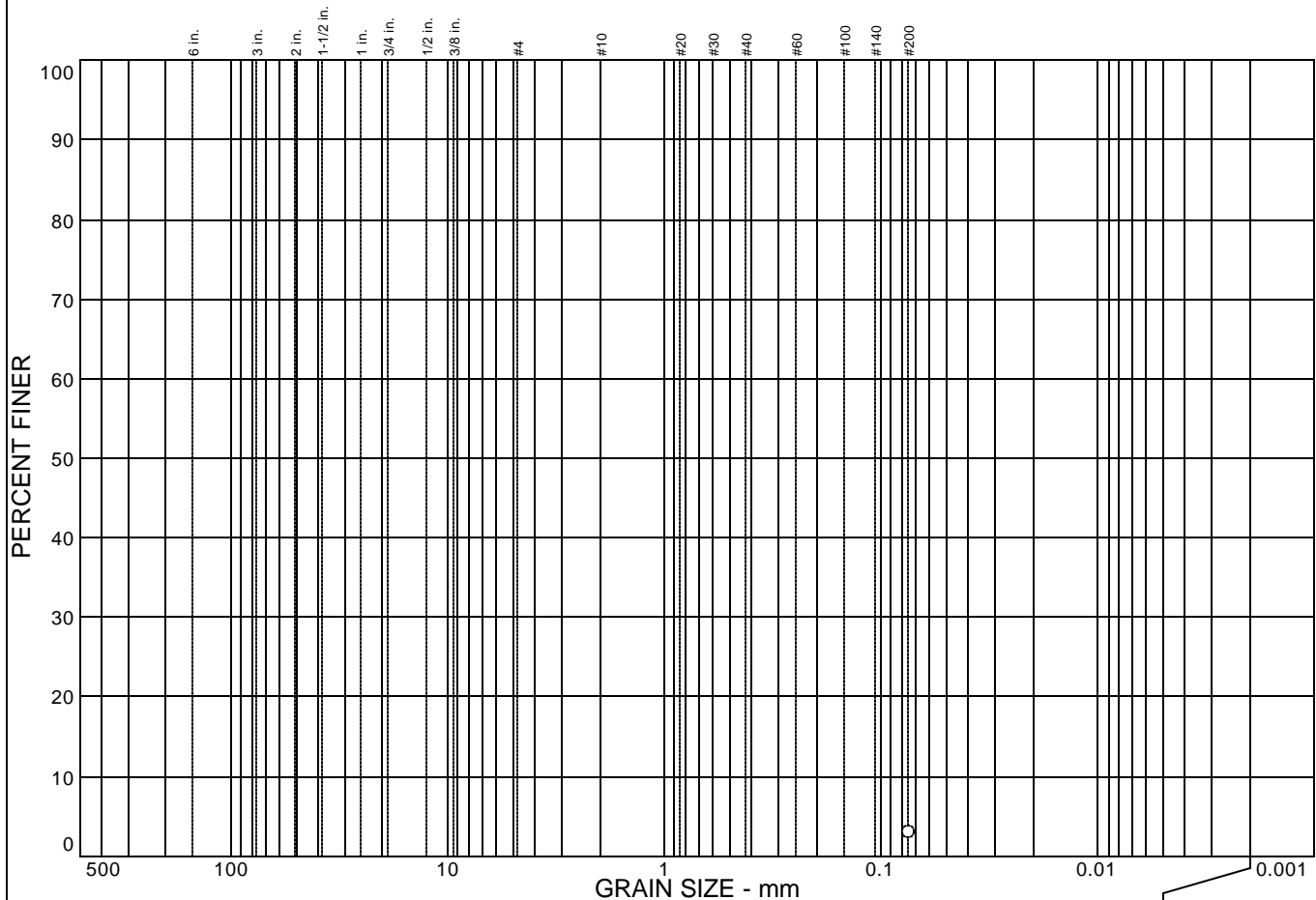

% COBBLES	% GRAVEL	% SAND	% SILT	% CLAY
			2.9	

SIEVE SIZE	PERCENT FINER	SPEC.* PERCENT	PASS? (X=NO)
#200	2.9		

Soil Description

Light yellowish brown SAND. Trace silt.

Atterberg Limits

PL= LL= PI=

Coefficients

D₈₅= D₆₀= D₅₀=
D₃₀= D₁₅= D₁₀=
C_u= C_c=

Classification

USCS= AASHTO=

Remarks

* (no specification provided)

Sample No.: B4 @ 10.5'
Location:

Source of Sample:

Date: 11/09/06
Elev./Depth: 10.5 feet



Client:
Project: Marina Coast Recycled Water Pipeline - Marina, CA

Project No.: 7496.1.001.01

Particle Size Distribution Report

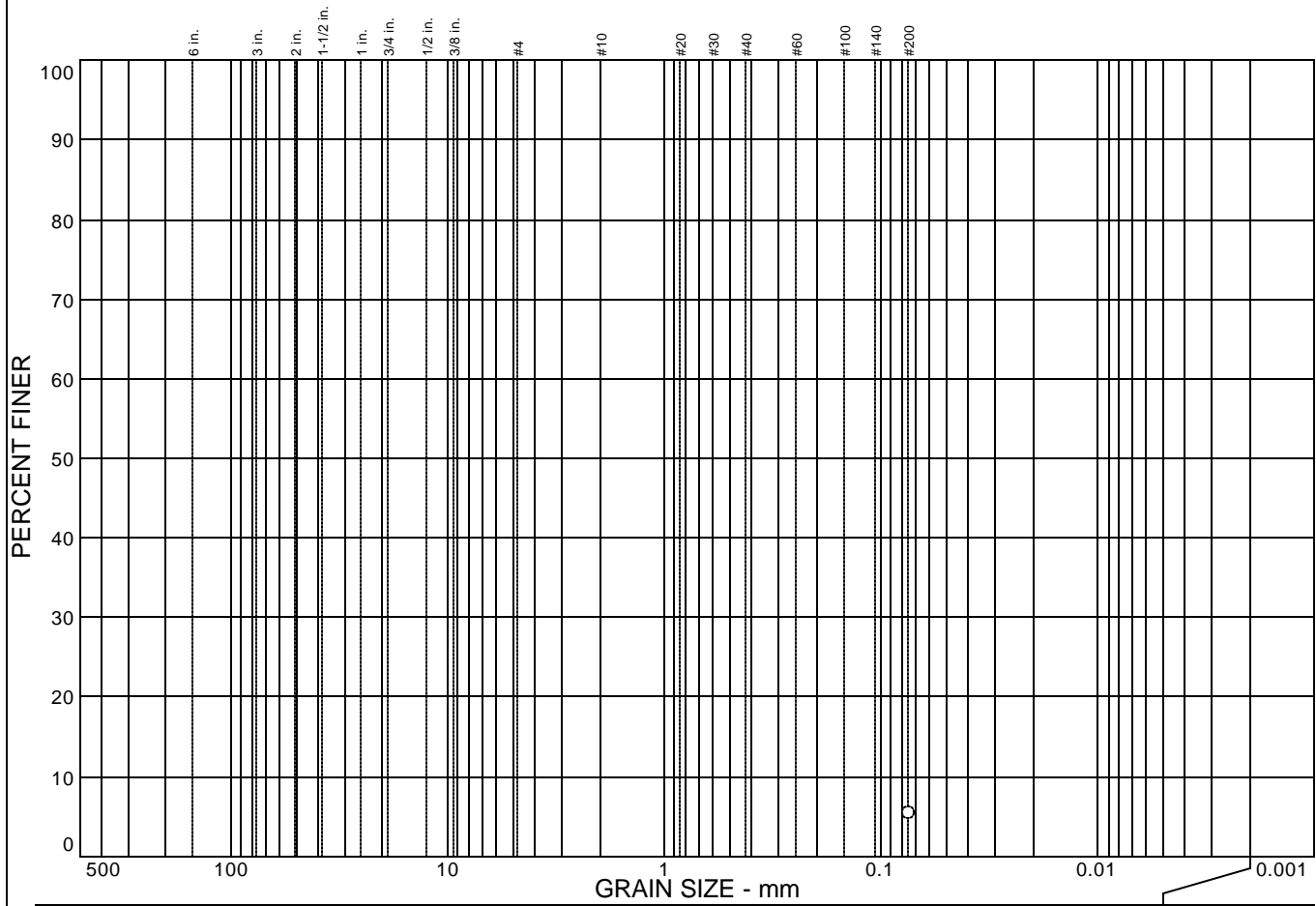

% COBBLES	% GRAVEL	% SAND	% SILT	% CLAY
			5.3	

SIEVE SIZE	PERCENT FINER	SPEC.* PERCENT	PASS? (X=NO)
#200	5.3		

Soil Description

Very dark grayish brown SAND. Trace silt.

Atterberg Limits

PL= LL= PI=

Coefficients

D₈₅= D₆₀= D₅₀=
D₃₀= D₁₅= D₁₀=
C_u= C_c=

Classification

USCS= AASHTO=

Remarks

* (no specification provided)

Sample No.: B5 @ 3.0'
Location:

Source of Sample:

Date: 11/08/06
Elev./Depth: 3.0 feet



Client:
Project: Marina Coast Recycled Water Pipeline - Marina, CA

Project No.: 7496.1.001.01

Particle Size Distribution Report

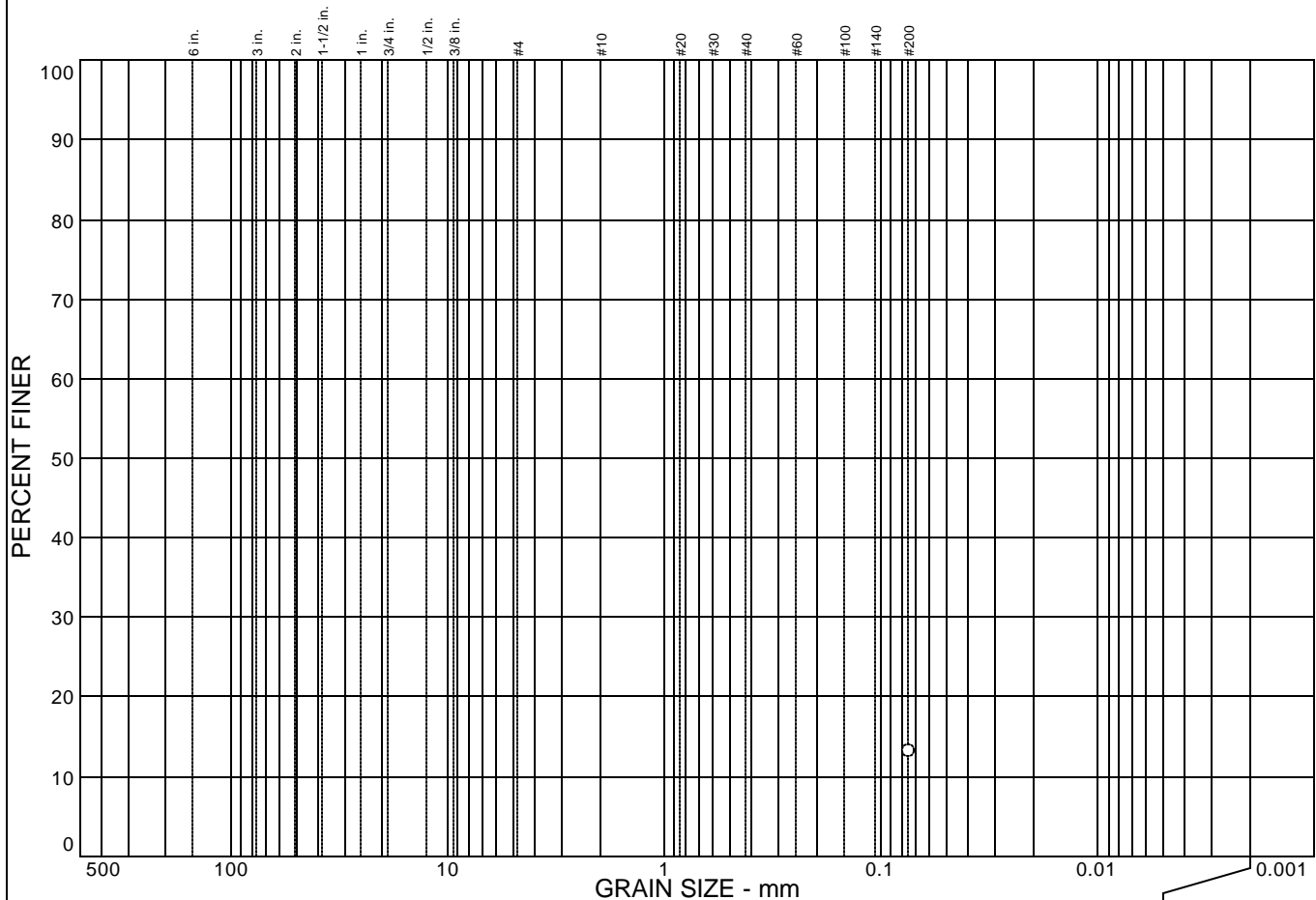

% COBBLES	% GRAVEL	% SAND	% SILT	% CLAY
			13.2	

SIEVE SIZE	PERCENT FINER	SPEC.* PERCENT	PASS? (X=NO)
#200	13.2		

Soil Description

Very dark grayish brown SAND with gravel and some silt.

Atterberg Limits

PL= LL= PI=

Coefficients

D₈₅= D₆₀= D₅₀=
D₃₀= D₁₅= D₁₀=
C_u= C_c=

Classification

USCS= AASHTO=

Remarks

* (no specification provided)

Sample No.: B5 @ 6.0'
Location:

Source of Sample:

Date: 11/08/06
Elev./Depth: 6.0 feet



Client:
Project: Marina Coast Recycled Water Pipeline - Marina, CA

Project No.: 7496.1.001.01

Particle Size Distribution Report

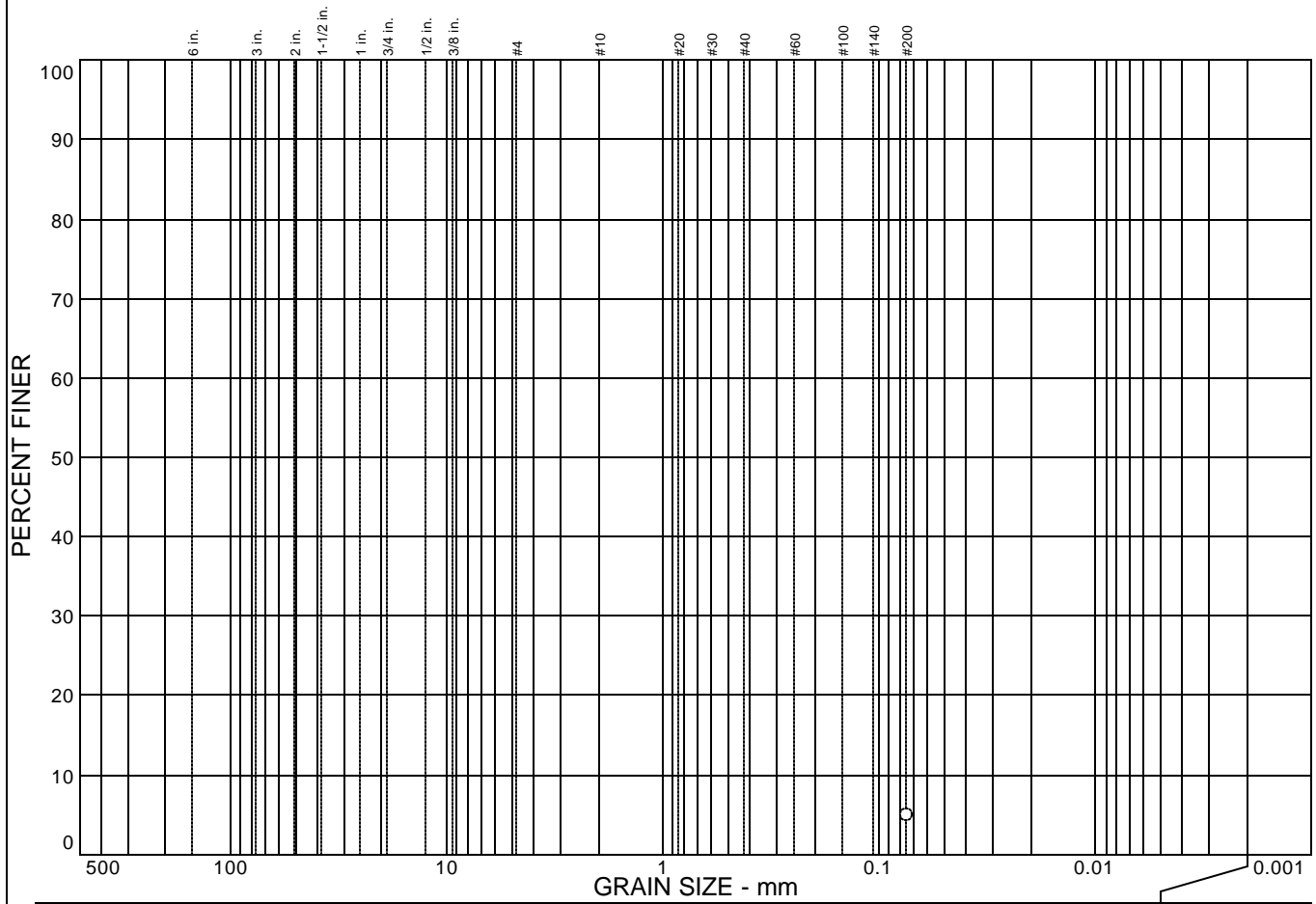

% COBBLES	% GRAVEL	% SAND	% SILT	% CLAY
			4.9	

SIEVE SIZE	PERCENT FINER	SPEC.* PERCENT	PASS? (X=NO)
#200	4.9		

Soil Description

Dark yellowish brown SAND with trace silt.

Atterberg Limits

PL= LL= PI=

Coefficients

D₈₅= D₆₀= D₅₀=
D₃₀= D₁₅= D₁₀=
C_u= C_c=

Classification

USCS= AASHTO=

Remarks

* (no specification provided)

Sample No.: B5 @ 8.0'
Location:

Source of Sample:

Date: 11/08/06
Elev./Depth: 8.0 feet



Client:
Project: Coast Recycled Water Pipeline - Marina, CA

Project No.: 7496.1.001.01

Particle Size Distribution Report

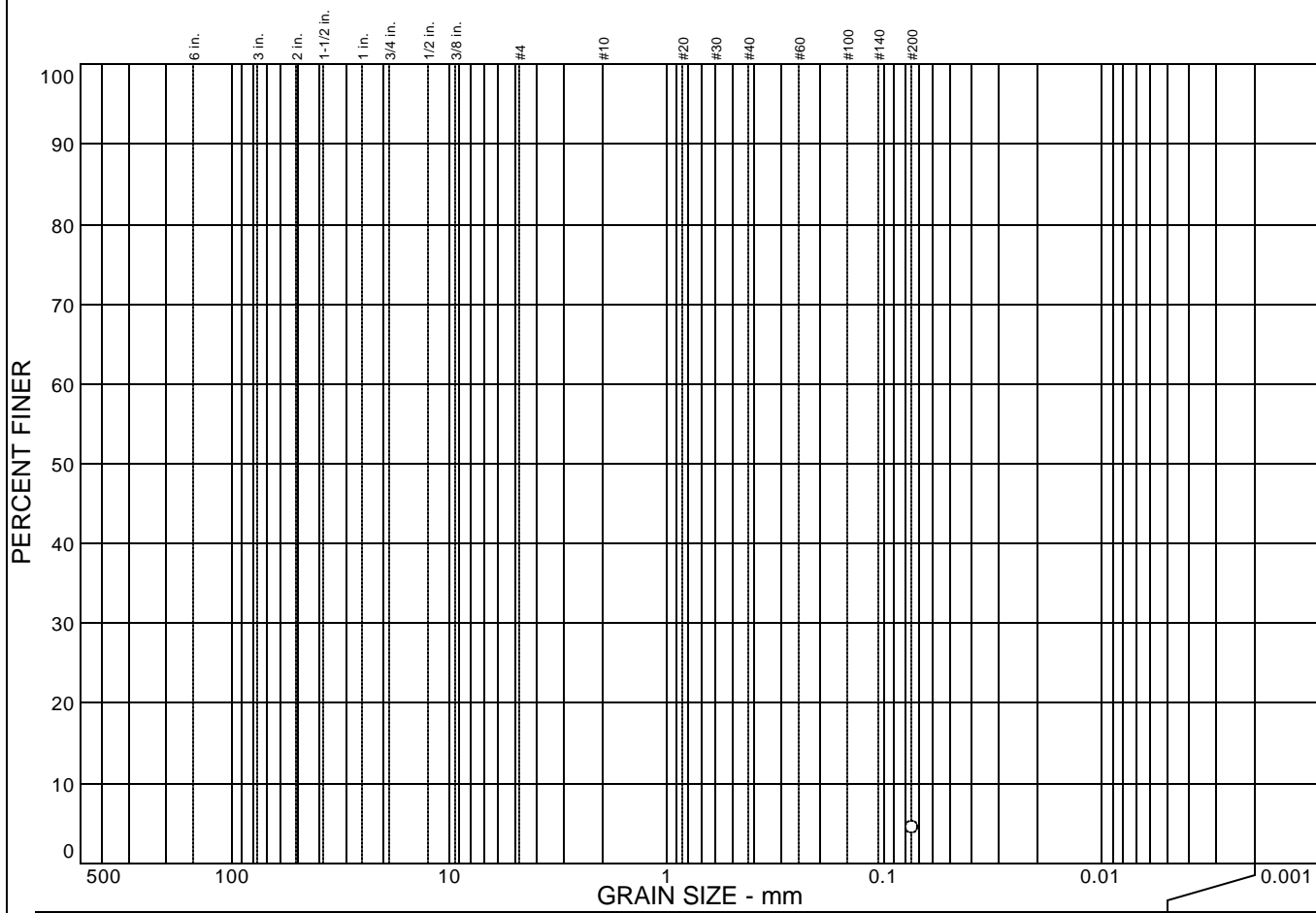

% COBBLES	% GRAVEL	% SAND	% SILT	% CLAY
			4.4	

SIEVE SIZE	PERCENT FINER	SPEC.* PERCENT	PASS? (X=NO)
#200	4.4		

Soil Description

Olive yellowish SAND. Trace silt.

Atterberg Limits

PL= LL= PI=

Coefficients

D₈₅= D₆₀= D₅₀=
D₃₀= D₁₅= D₁₀=
C_u= C_c=

Classification

USCS= AASHTO=

Remarks

* (no specification provided)

Sample No.: B5 @ 11'
Location:

Source of Sample:

Date: 11/08/06
Elev./Depth: 11.0 feet



Client:
Project: Marina Coast Recycled Water Pipeline - Marina, CA

Project No.: 7496.1.001.01

Particle Size Distribution Report

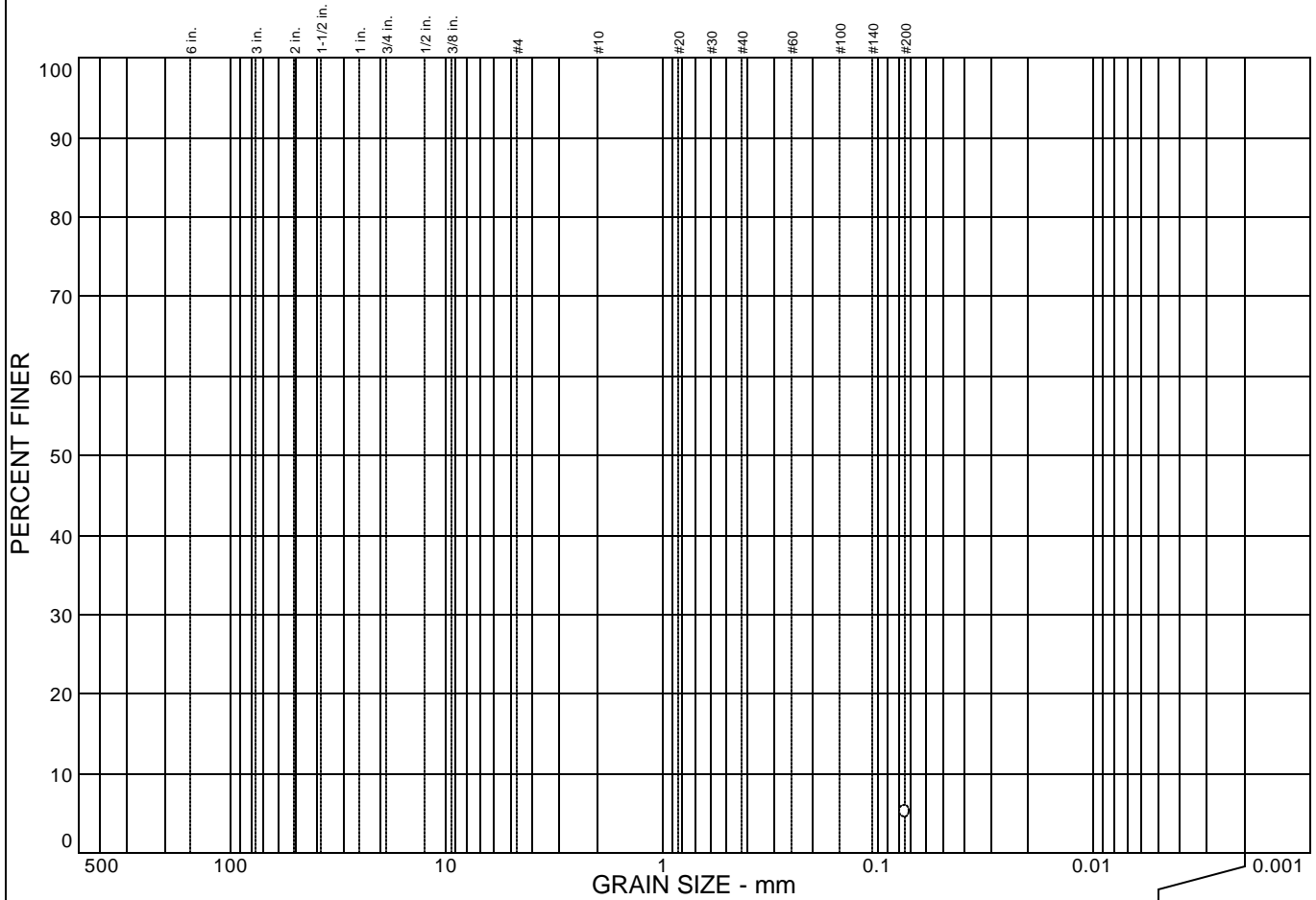

% COBBLES	% GRAVEL	% SAND	% SILT	% CLAY
			5.2	

SIEVE SIZE	PERCENT FINER	SPEC.* PERCENT	PASS? (X=NO)
#200	5.2		

Soil Description

Olive yellow SAND. Trace silt.

Atterberg Limits

PL= LL= PI=

Coefficients

D₈₅= D₆₀= D₅₀=
D₃₀= D₁₅= D₁₀=
C_u= C_c=

Classification

USCS= AASHTO=

Remarks

* (no specification provided)

Sample No.: B5 @ 16.0' **Source of Sample:** **Date:** 11/09/06
Location: **Elev./Depth:** 16.0 feet

Particle Size Distribution Report

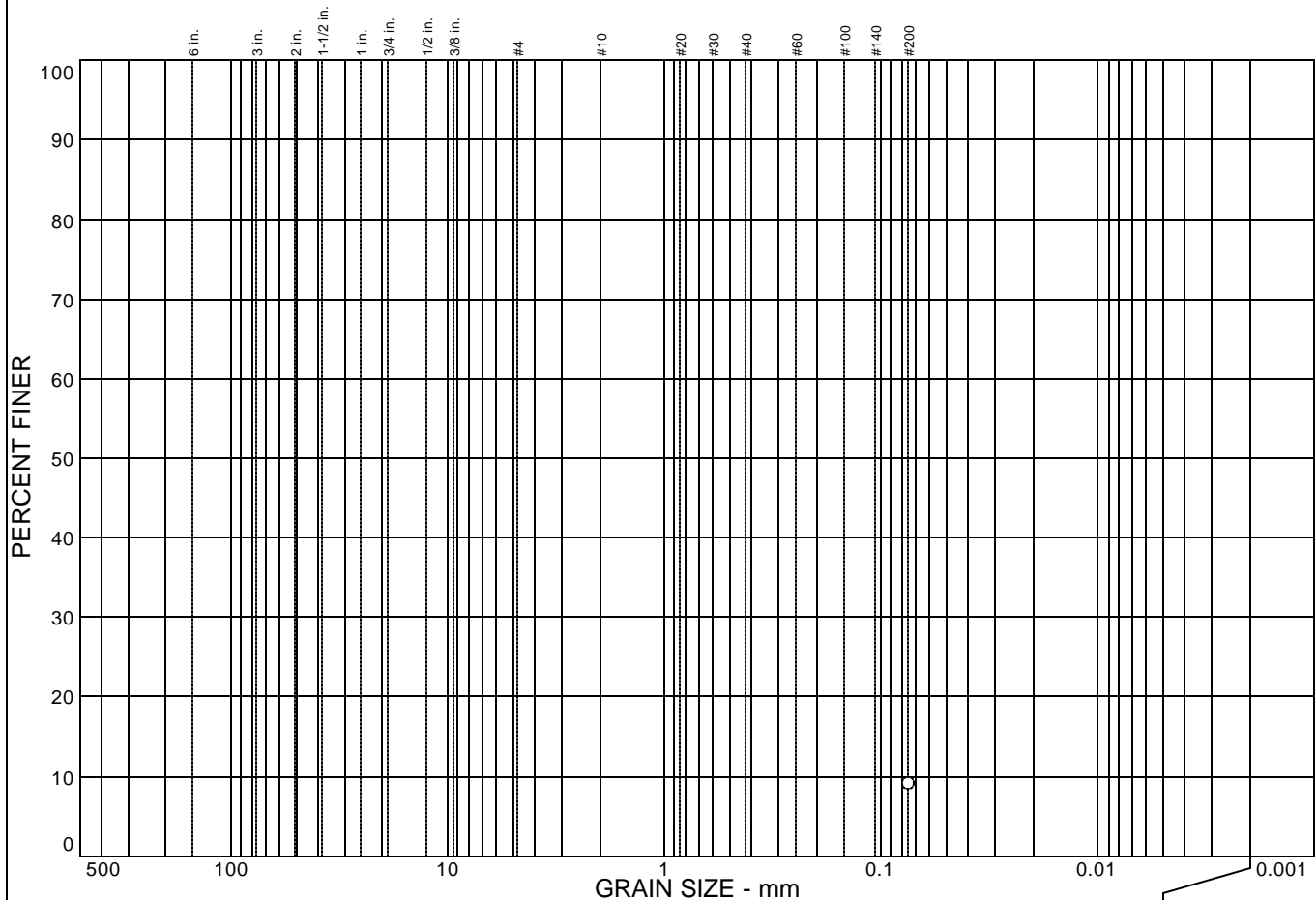

% COBBLES	% GRAVEL	% SAND	% SILT	% CLAY
			9.0	

SIEVE SIZE	PERCENT FINER	SPEC.* PERCENT	PASS? (X=NO)
#200	9.0		

Soil Description

Dark yellowish brown SAND with some silt.

Atterberg Limits

PL= LL= PI=

Coefficients

D₈₅= D₆₀= D₅₀=
D₃₀= D₁₅= D₁₀=
C_u= C_c=

Classification

USCS= AASHTO=

Remarks

* (no specification provided)

Sample No.: B6 @ 3.0'
Location:

Source of Sample:

Date: 11/08/06
Elev./Depth: 3.0 feet



Client:
Project: Marina Coast Recycled Water Pipeline - Marina, CA

Project No.: 7496.1.001.01

Particle Size Distribution Report

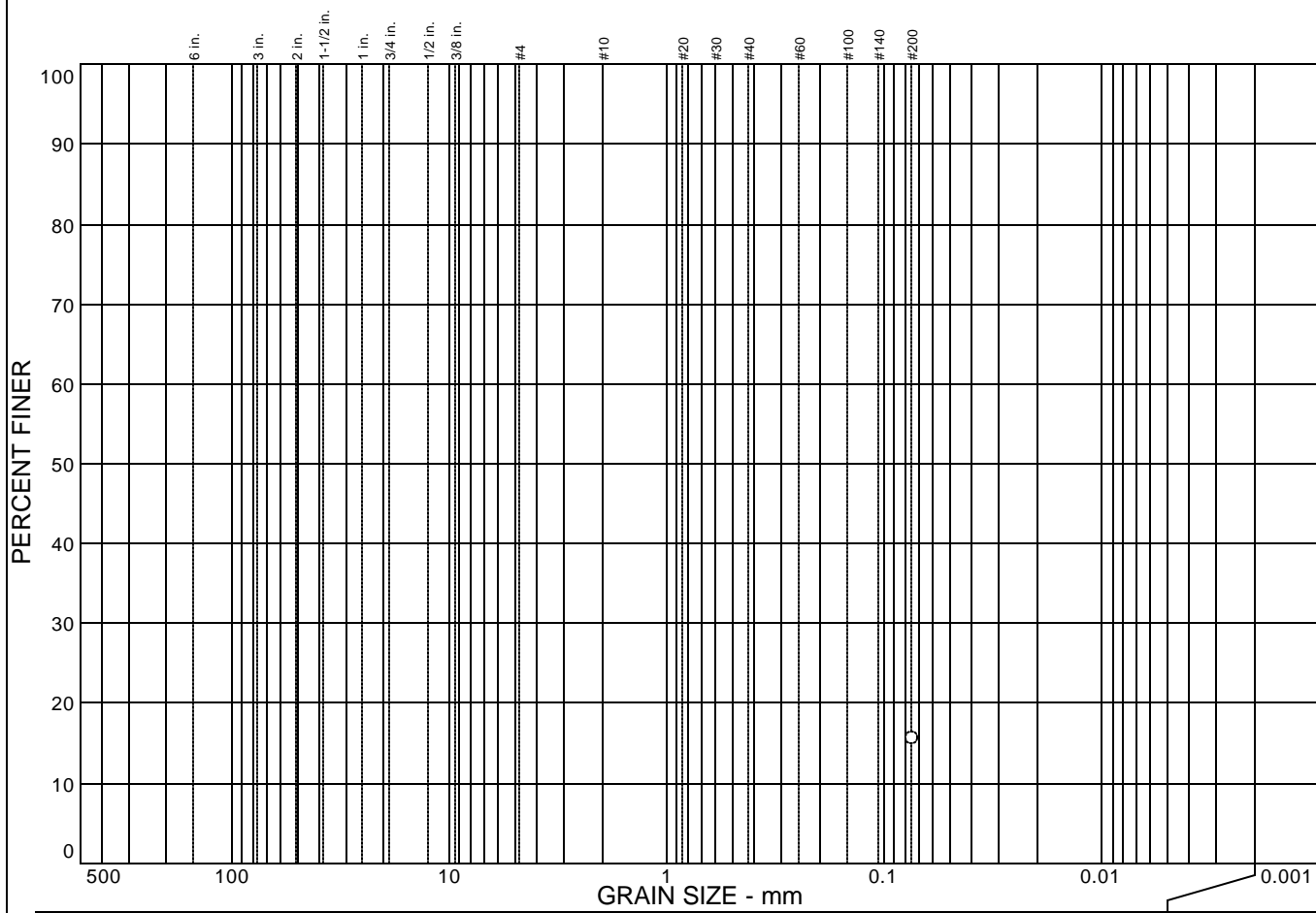

% COBBLES	% GRAVEL	% SAND	% SILT	% CLAY
			15.6	

SIEVE SIZE	PERCENT FINER	SPEC.* PERCENT	PASS? (X=NO)
#200	15.6		

Soil Description

Dark yellowish brown silty SAND.

Atterberg Limits

PL= LL= PI=

Coefficients

D₈₅= D₆₀= D₅₀=
D₃₀= D₁₅= D₁₀=
C_u= C_c=

Classification

USCS= AASHTO=

Remarks

* (no specification provided)

Sample No.: B6 @ 6.0'
Location:

Source of Sample:

Date: 11/08/06
Elev./Depth: 6.0 feet



Client:
Project: Marina Coast Recycled Water Pipeline - Marina, CA

Project No.: 7496.1.001.01

Particle Size Distribution Report

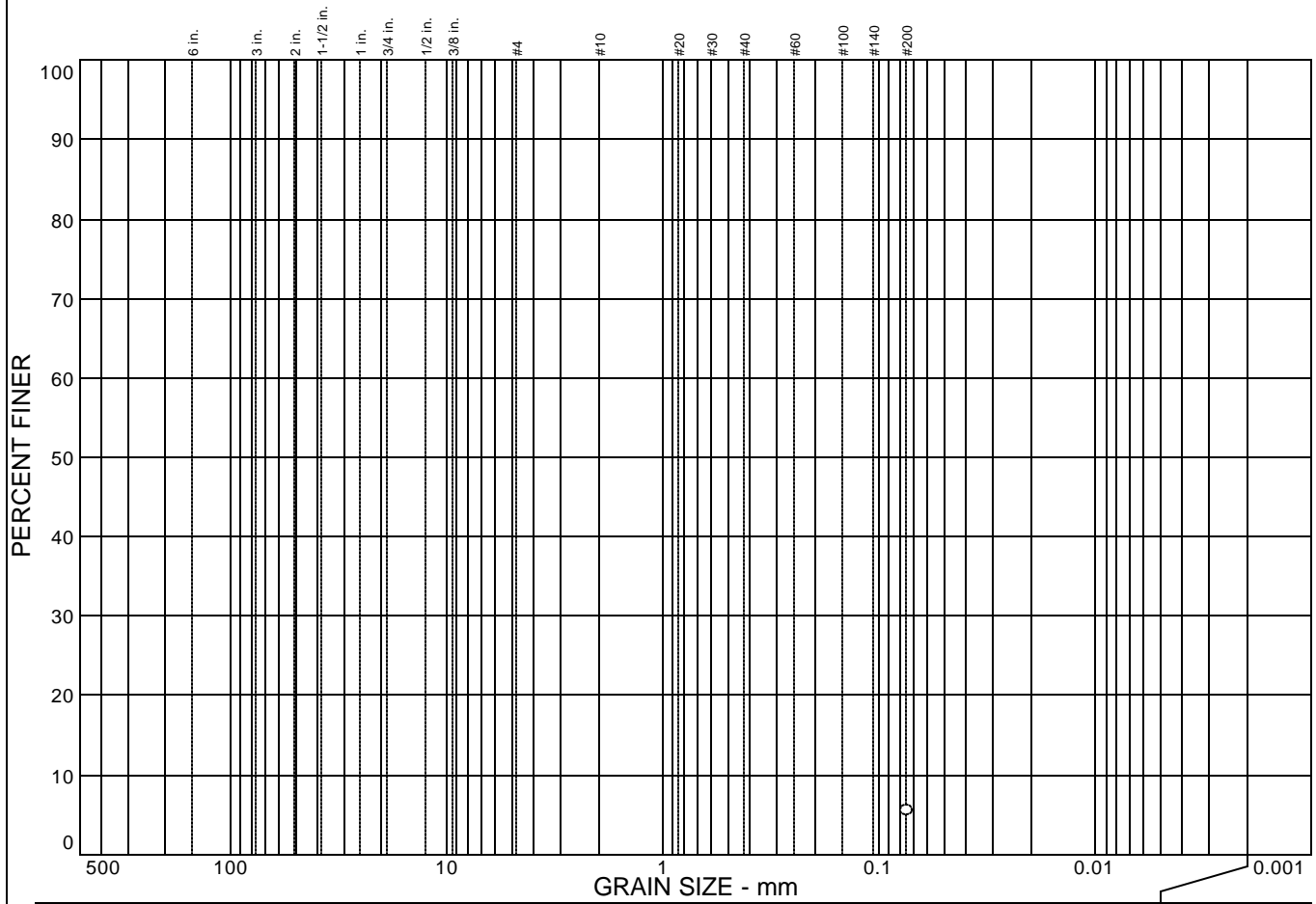

% COBBLES	% GRAVEL	% SAND	% SILT	% CLAY
			5.5	

SIEVE SIZE	PERCENT FINER	SPEC.* PERCENT	PASS? (X=NO)
#200	5.5		

Soil Description

Yellowish brown SAND with some silt.

Atterberg Limits

PL= LL= PI=

Coefficients

D₈₅= D₆₀= D₅₀=
D₃₀= D₁₅= D₁₀=
C_u= C_c=

Classification

USCS= AASHTO=

Remarks

* (no specification provided)

Sample No.: B6 @ 8.0'
Location:

Source of Sample:

Date: 11/08/06
Elev./Depth: 8.0 feet



Client:
Project: Marina Coast Recycled Water Pipeline - Marina, CA

Project No.: 7496.1.001.01

Particle Size Distribution Report

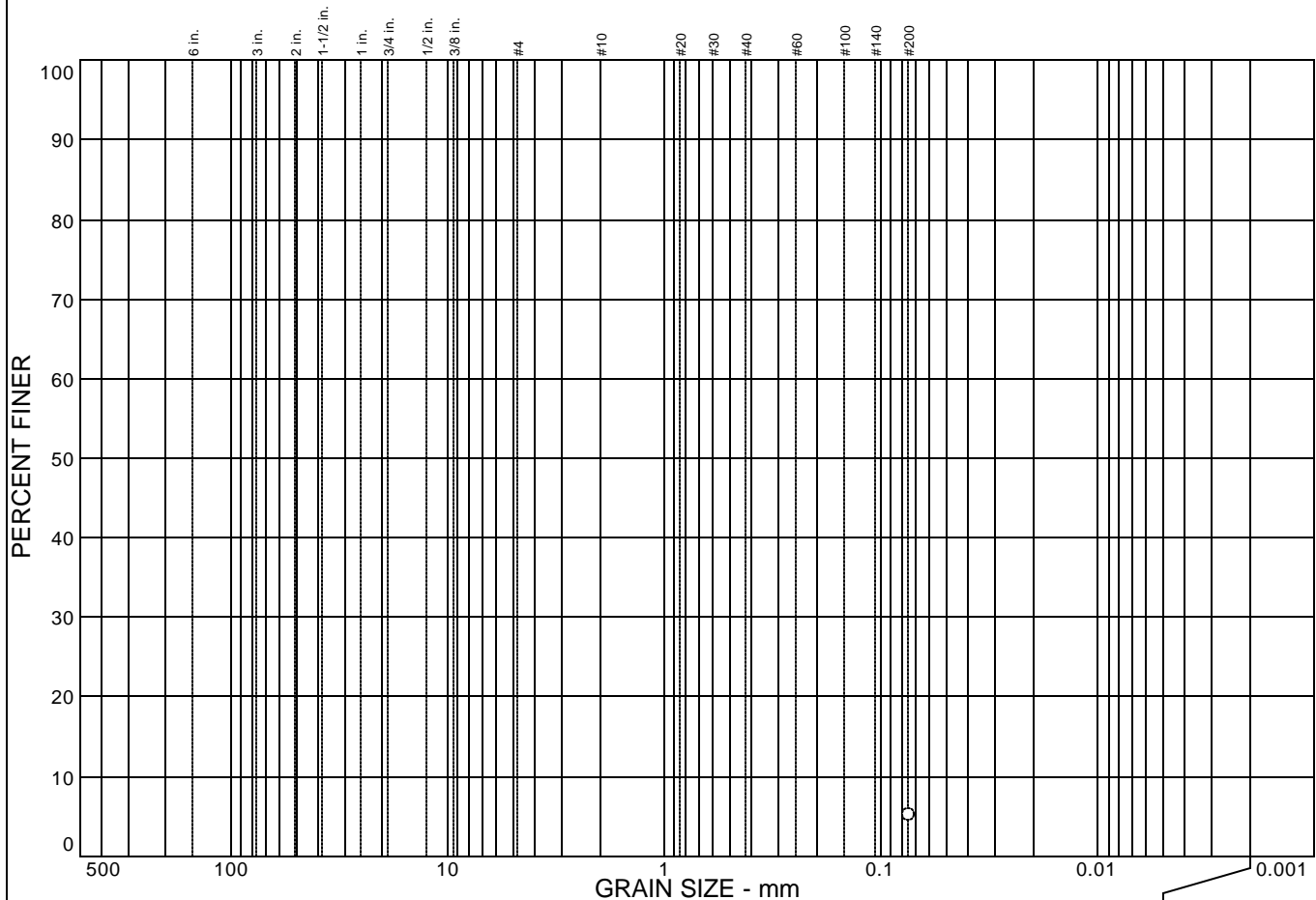

% COBBLES	% GRAVEL	% SAND	% SILT	% CLAY
			5.2	

SIEVE SIZE	PERCENT FINER	SPEC.* PERCENT	PASS? (X=NO)
#200	5.2		

Soil Description

Yellowish brown SAND with some silt.

Atterberg Limits

PL= LL= PI=

Coefficients

D₈₅= D₆₀= D₅₀=
D₃₀= D₁₅= D₁₀=
C_u= C_c=

Classification

USCS= AASHTO=

Remarks

* (no specification provided)

Sample No.: B6 @ 11.0'
Location:

Source of Sample:

Date: 11/08/06
Elev./Depth: 11.0 feet



Client:
Project: Marina Coast Recycled Water Pipeline - Marina, CA

Project No.: 7496.1.001.01

Particle Size Distribution Report

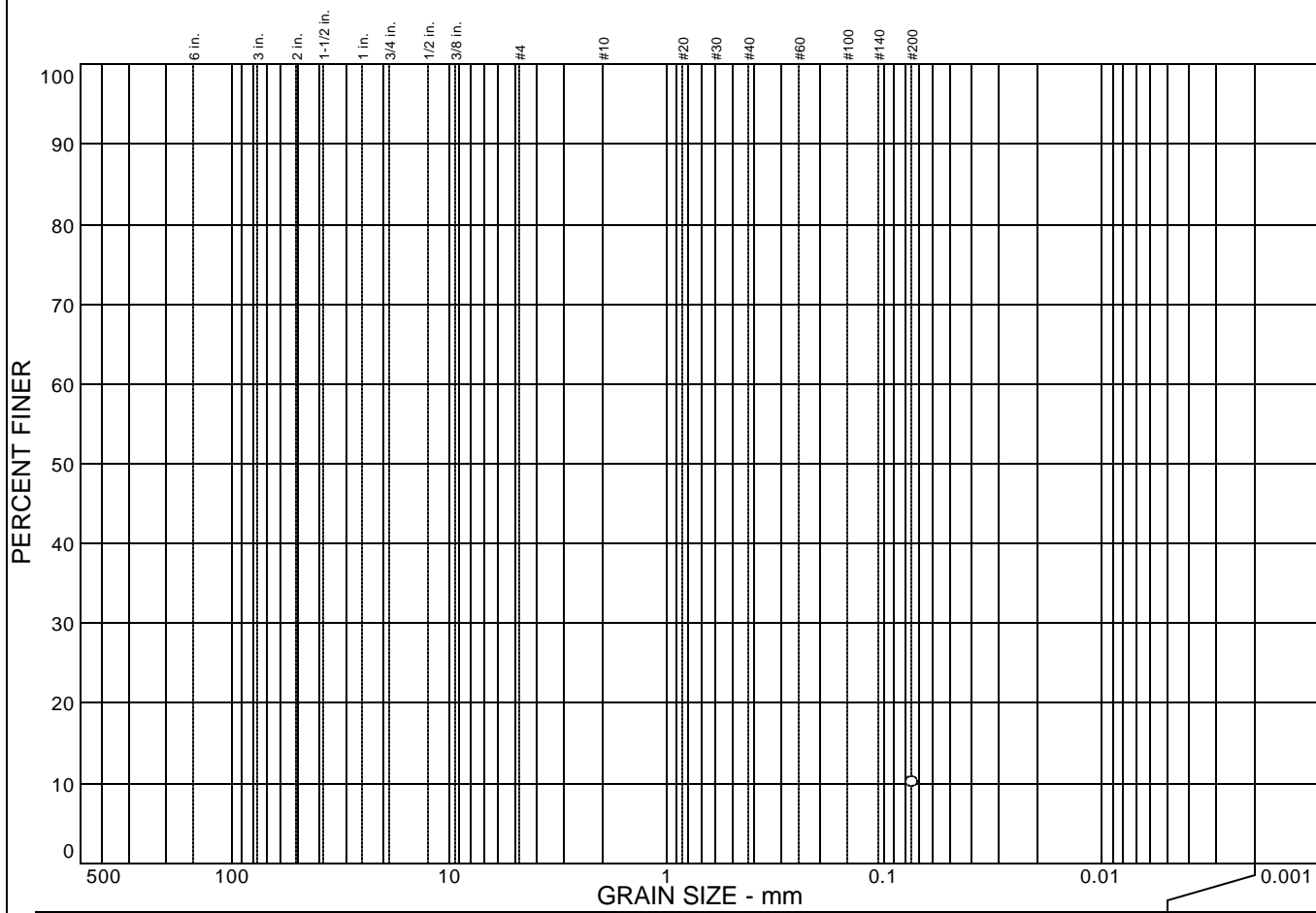

% COBBLES	% GRAVEL	% SAND	% SILT	% CLAY
			10.1	

SIEVE SIZE	PERCENT FINER	SPEC.* PERCENT	PASS? (X=NO)
#200	10.1		

Soil Description

Dark olive brown SAND with some silt.

Atterberg Limits

PL= LL= PI=

Coefficients

D₈₅= D₆₀= D₅₀=
D₃₀= D₁₅= D₁₀=
C_u= C_c=

Classification

USCS= AASHTO=

Remarks

* (no specification provided)

Sample No.: B7 @ 2.0'
Location:

Source of Sample:

Date: 11/09/06
Elev./Depth: 2.0 feet



Client:
Project: Marina Coast Recycled Water Pipeline - Marina, CA

Project No.: 7496.1.001.01

Particle Size Distribution Report

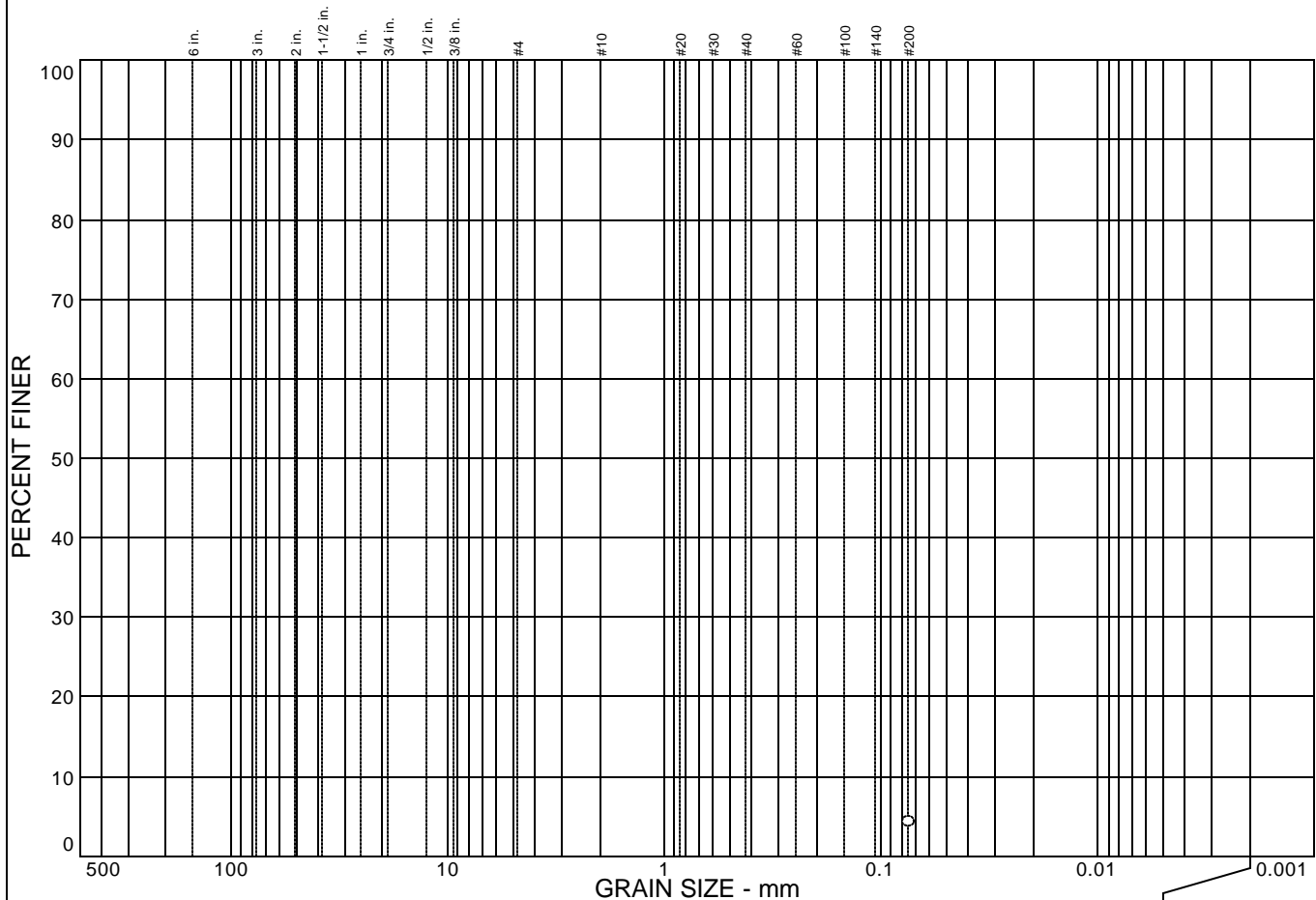

% COBBLES	% GRAVEL	% SAND	% SILT	% CLAY
			4.3	

SIEVE SIZE	PERCENT FINER	SPEC.* PERCENT	PASS? (X=NO)
#200	4.3		

Soil Description

Light yellowish brown SAND. Trace silt.

Atterberg Limits

PL= LL= PI=

Coefficients

D₈₅= D₆₀= D₅₀=
D₃₀= D₁₅= D₁₀=
C_u= C_c=

Classification

USCS= AASHTO=

Remarks

* (no specification provided)

Sample No.: B7 @ 6.0'
Location:

Source of Sample:

Date: 11/09/06
Elev./Depth: 6.0 feet



Client:
Project: Marina Coast Recycled Water Pipeline - Marina, CA

Project No.: 7496.1.001.01

Particle Size Distribution Report

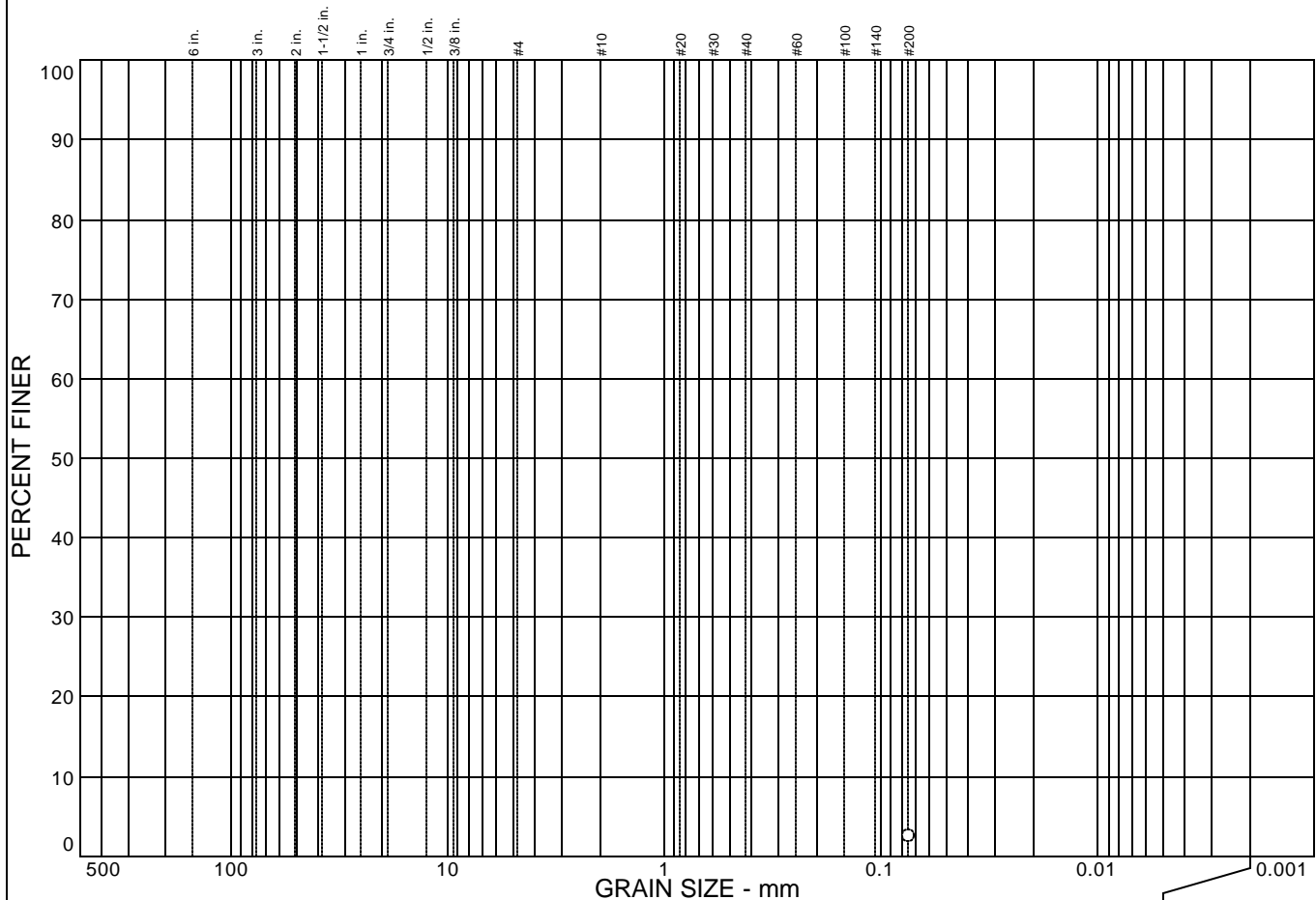

% COBBLES	% GRAVEL	% SAND	% SILT	% CLAY
			2.5	

SIEVE SIZE	PERCENT FINER	SPEC.* PERCENT	PASS? (X=NO)
#200	2.5		

Soil Description

Light yellowish brown SAND. Trace silt.

Atterberg Limits

PL= LL= PI=

Coefficients

D₈₅= D₆₀= D₅₀=
D₃₀= D₁₅= D₁₀=
C_u= C_c=

Classification

USCS= AASHTO=

Remarks

* (no specification provided)

Sample No.: B7 @ 11.0'
Location:

Source of Sample:

Date: 11/09/06
Elev./Depth: 11.0 feet



Client:
Project: Marina Coast Recycled Water Pipeline - Marina, CA

Project No.: 7496.1.001.01

Particle Size Distribution Report

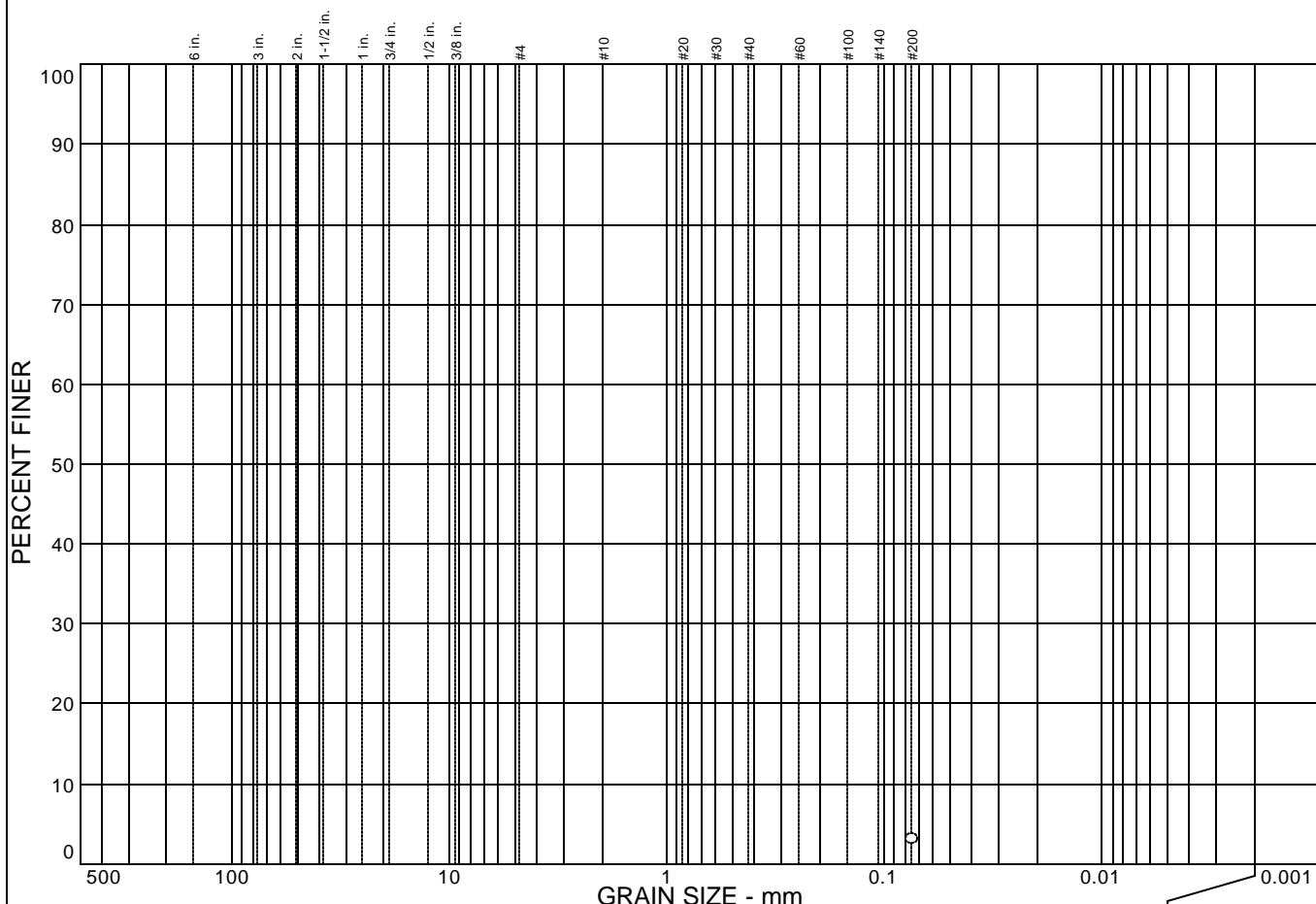

% COBBLES	% GRAVEL	% SAND	% SILT	% CLAY
			3.1	

SIEVE SIZE	PERCENT FINER	SPEC.* PERCENT	PASS? (X=NO)
#200	3.1		

Soil Description

Light yellowish brown SAND. Trace silt.

Atterberg Limits

PL= LL= PI=

Coefficients

D₈₅= D₆₀= D₅₀=
D₃₀= D₁₅= D₁₀=
C_u= C_c=

Classification

USCS= AASHTO=

Remarks

* (no specification provided)

Sample No.: B7 @ 26.0' **Source of Sample:** **Date:** 11/09/06
Location: **Elev./Depth:** 26.0 feet

Particle Size Distribution Report

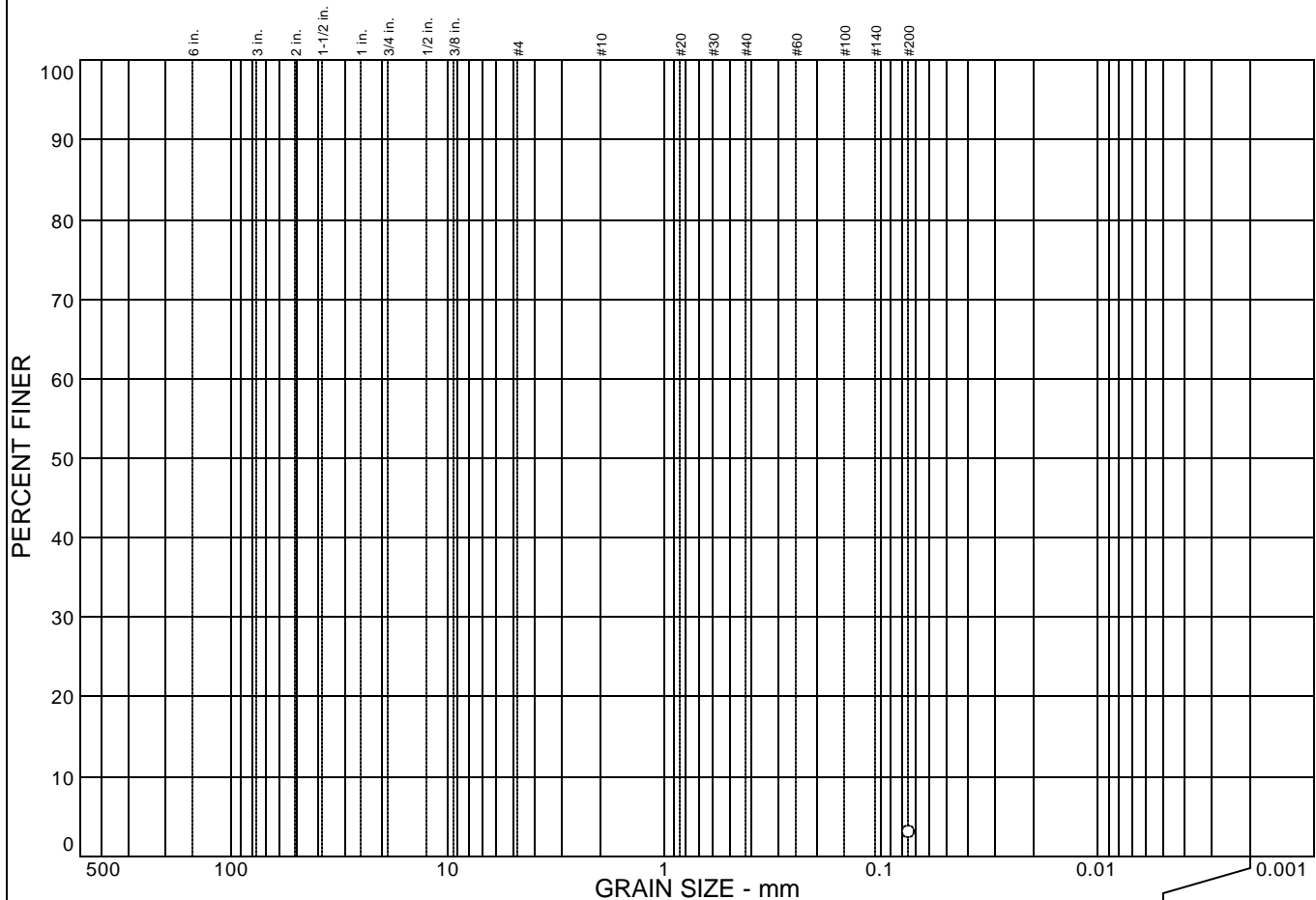

% COBBLES	% GRAVEL	% SAND	% SILT	% CLAY
			2.9	

SIEVE SIZE	PERCENT FINER	SPEC.* PERCENT	PASS? (X=NO)
#200	2.9		

Soil Description

Brownish yellow SAND. Trace silt.

Atterberg Limits

PL= LL= PI=

Coefficients

D₈₅= D₆₀= D₅₀=
D₃₀= D₁₅= D₁₀=
C_u= C_c=

Classification

USCS= AASHTO=

Remarks

* (no specification provided)

Sample No.: B8 @ 3.0'
Location:

Source of Sample:

Date: 11/08/06
Elev./Depth: 3.0 feet



Client:
Project: Coast Recycled Water Pipeline - Marina, CA

Project No.: 7496.1.001.01

Particle Size Distribution Report

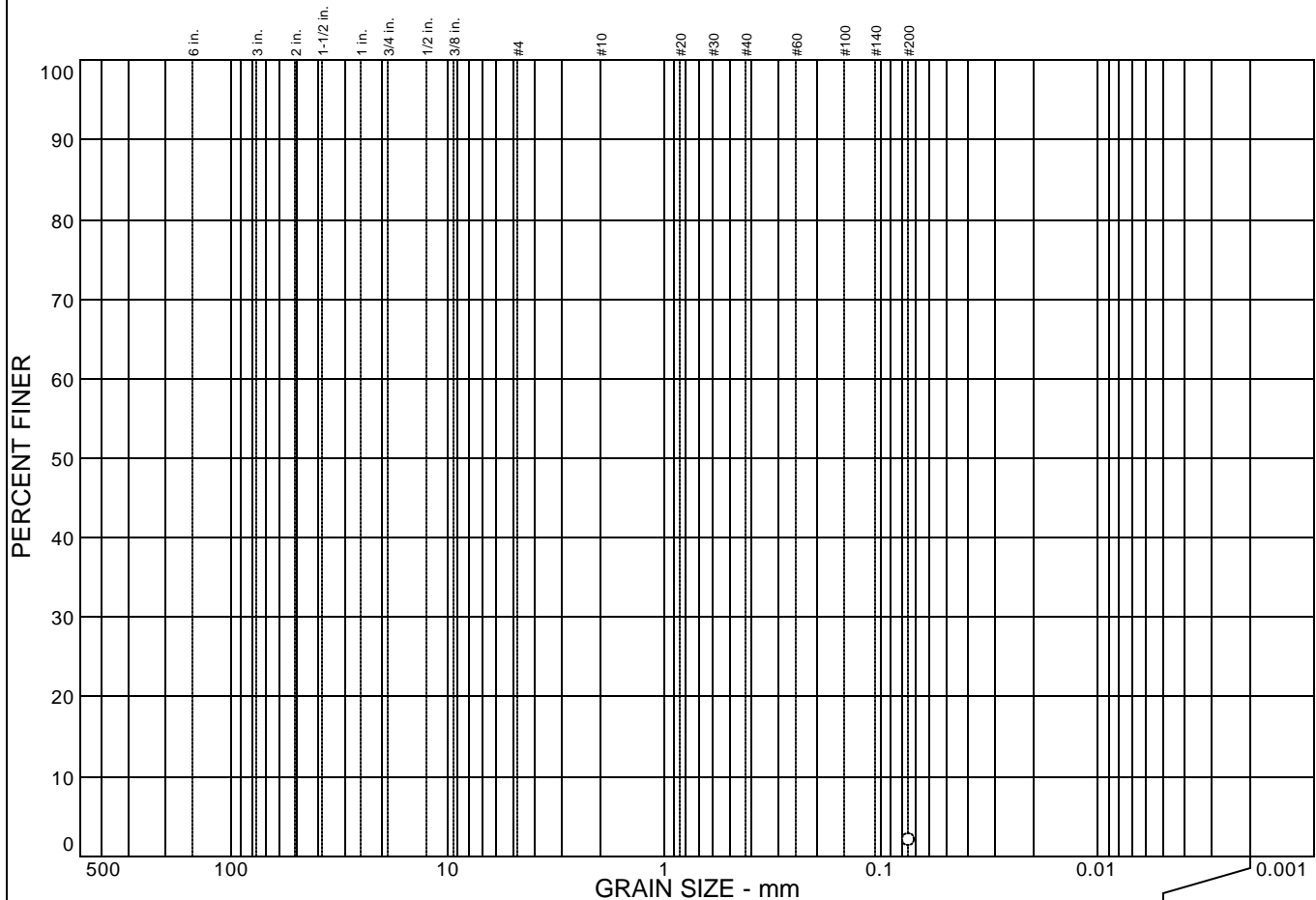

% COBBLES	% GRAVEL	% SAND	% SILT	% CLAY
			1.9	

SIEVE SIZE	PERCENT FINER	SPEC.* PERCENT	PASS? (X=NO)
#200	1.9		

Soil Description

Brownish yellow SAND. Trace silt.

Atterberg Limits

PL= LL= PI=

Coefficients

D₈₅= D₆₀= D₅₀=
D₃₀= D₁₅= D₁₀=
C_u= C_c=

Classification

USCS= AASHTO=

Remarks

* (no specification provided)

Sample No.: B8 @ 5.5'
Location:

Source of Sample:

Date: 11/08/06
Elev./Depth: 5.5 feet



Client:
Project: Coast Recycled Water Pipeline - Marina, CA

Project No.: 7496.1.001.01

Particle Size Distribution Report

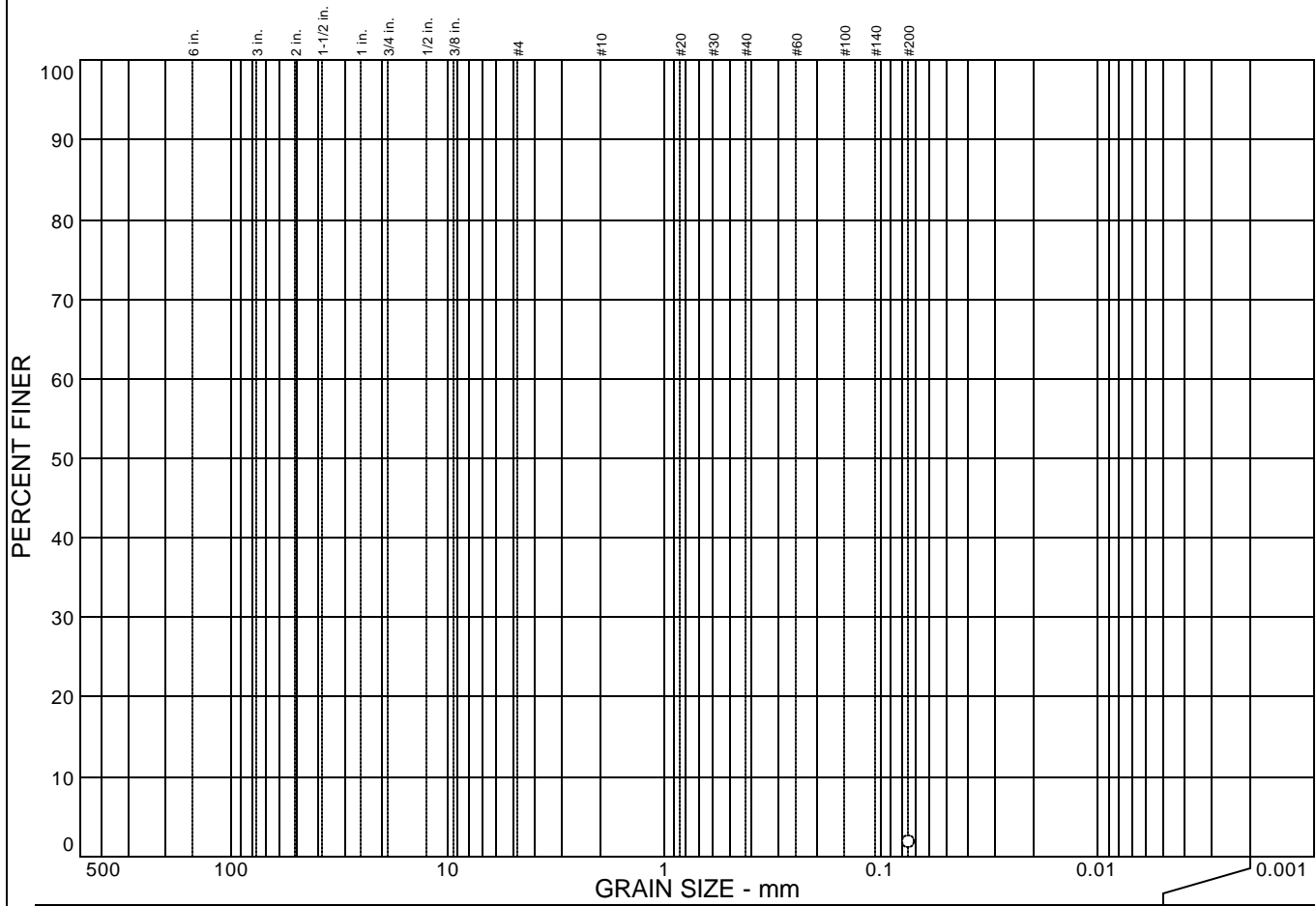

% COBBLES	% GRAVEL	% SAND	% SILT	% CLAY
			1.8	

SIEVE SIZE	PERCENT FINER	SPEC.* PERCENT	PASS? (X=NO)
#200	1.8		

Soil Description

Olive yellow SAND. Trace silt.

Atterberg Limits

PL= LL= PI=

Coefficients

D₈₅= D₆₀= D₅₀=
 D₃₀= D₁₅= D₁₀=
 C_u= C_c=

Classification

USCS= AASHTO=

Remarks

* (no specification provided)

Sample No.: B8 @ 7.5'
Location:

Source of Sample:

Date: 11/08/06
Elev./Depth: 7.5 feet



Client:
Project: Coast Recycled Water Pipeline - Marina, CA

Project No.: 7496.1.001.01

Particle Size Distribution Report

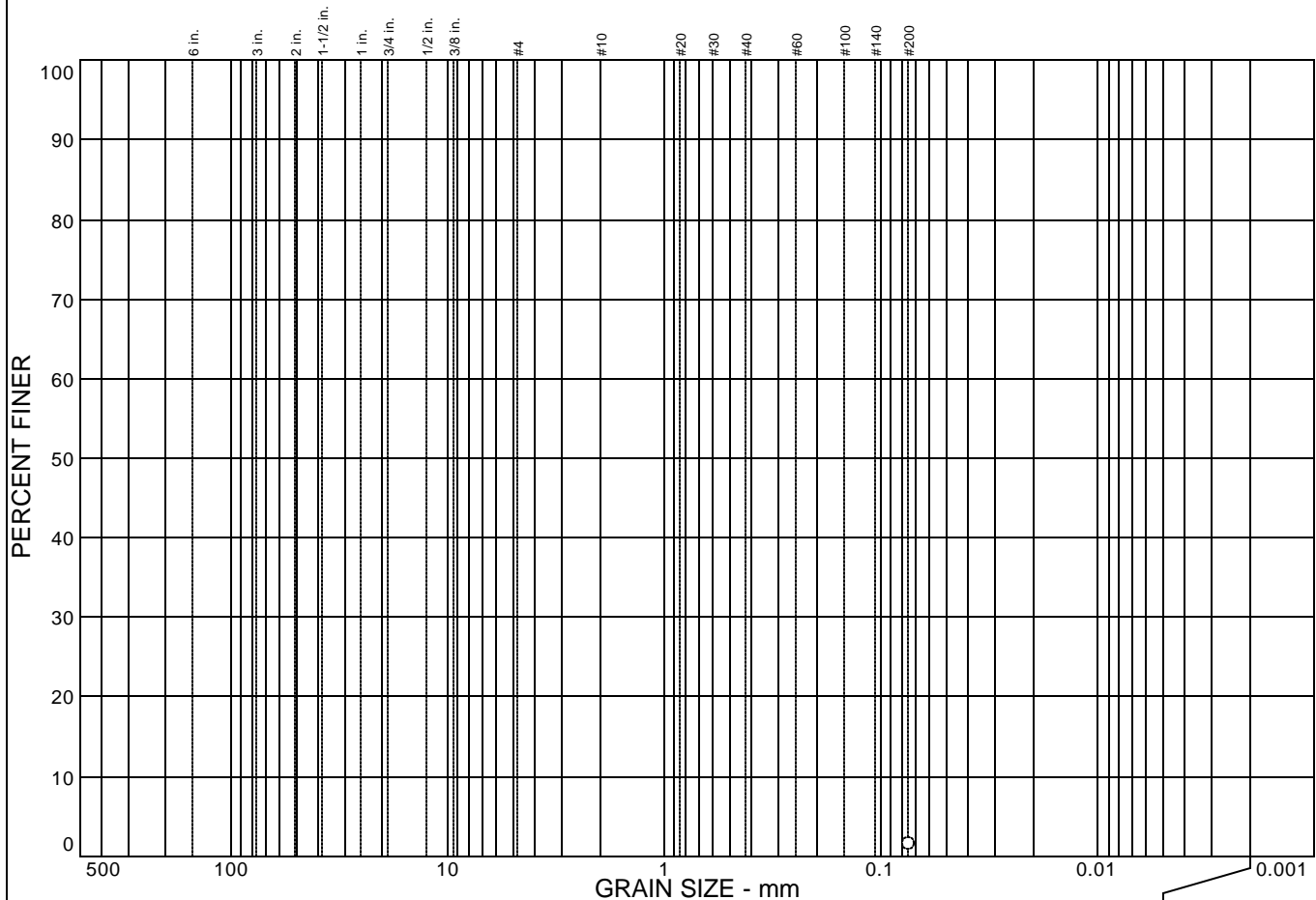

% COBBLES	% GRAVEL	% SAND	% SILT	% CLAY
			1.5	

SIEVE SIZE	PERCENT FINER	SPEC.* PERCENT	PASS? (X=NO)
#200	1.5		

Soil Description

Olive yellow SAND. Trace silt.

Atterberg Limits

PL= LL= PI=

Coefficients

D₈₅= D₆₀= D₅₀=
D₃₀= D₁₅= D₁₀=
C_u= C_c=

Classification

USCS= AASHTO=

Remarks

* (no specification provided)

Sample No.: B8 @ 10.5'
Location:

Source of Sample:

Date: 11/08/06
Elev./Depth: 10.5 feet



Client:
Project: Coast Recycled Water Pipeline - Marina, CA

Project No.: 7496.1.001.01

Particle Size Distribution Report

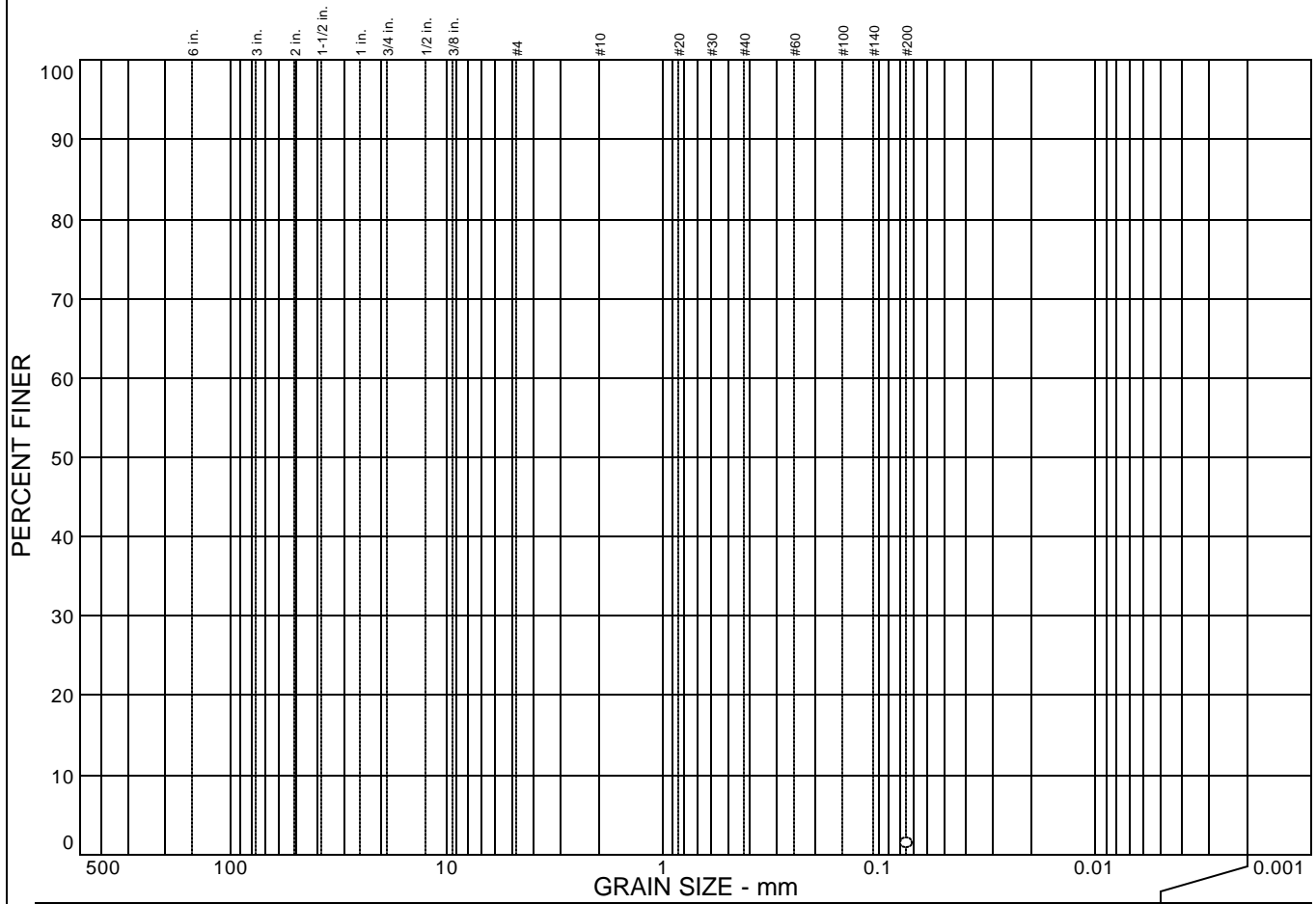

% COBBLES	% GRAVEL	% SAND	% SILT	% CLAY
			1.4	

SIEVE SIZE	PERCENT FINER	SPEC.* PERCENT	PASS? (X=NO)
#200	1.4		

Soil Description

Olive yellow SAND. Trace silt.

Atterberg Limits

PL= LL= PI=

Coefficients

D₈₅= D₆₀= D₅₀=
D₃₀= D₁₅= D₁₀=
C_u= C_c=

Classification

USCS= AASHTO=

Remarks

* (no specification provided)

Sample No.: B8 @ 16'
Location:

Source of Sample:

Date: 11/08/06
Elev./Depth: 16.0 feet



Client:
Project: Coast Recycled Water Pipeline - Marina, CA

Project No.: 7496.1.001.01

Particle Size Distribution Report

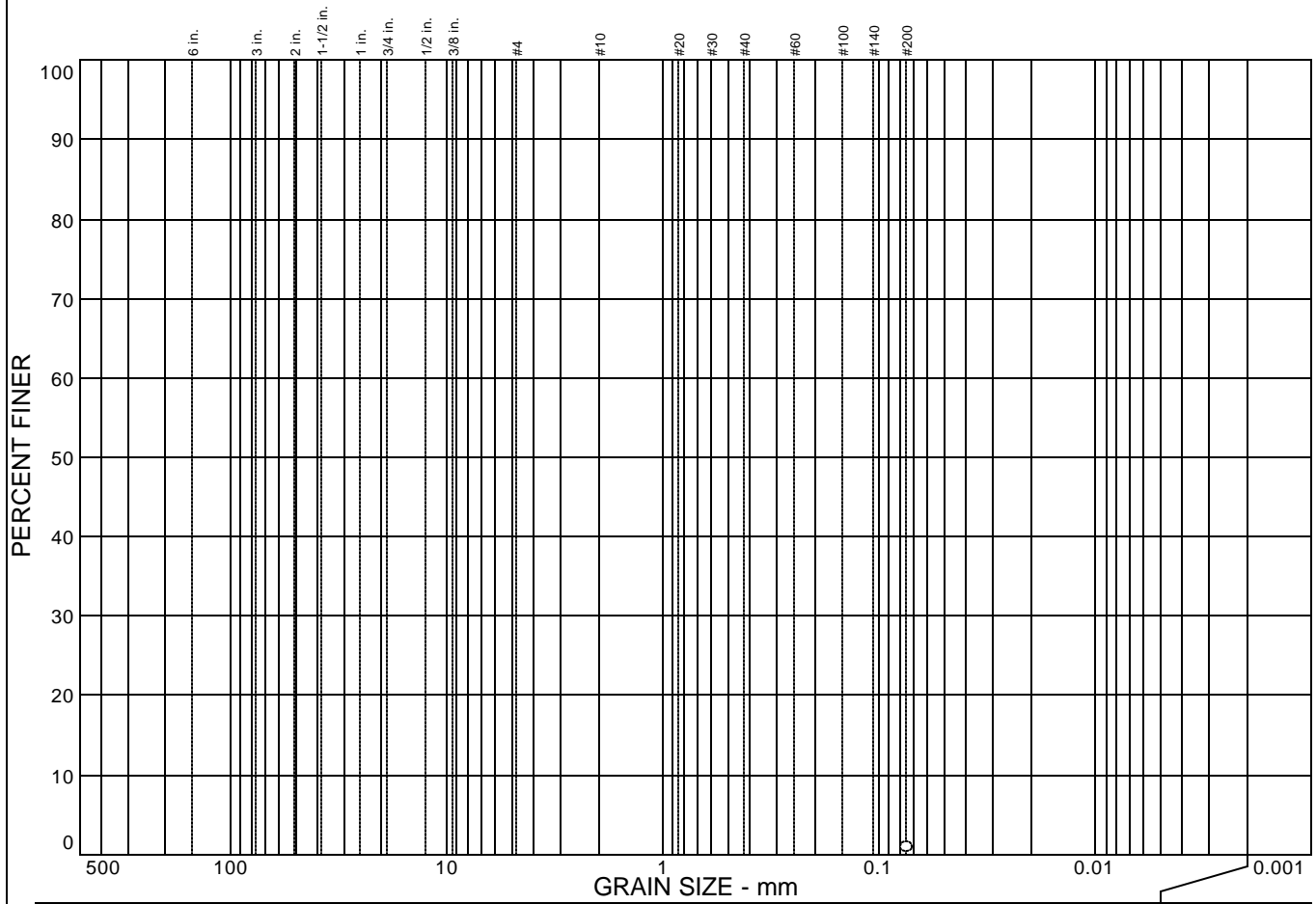

% COBBLES	% GRAVEL	% SAND	% SILT	% CLAY
			0.9	

SIEVE SIZE	PERCENT FINER	SPEC.* PERCENT	PASS? (X=NO)
#200	0.9		

Soil Description

Olive yellow SAND. Trace silt.

Atterberg Limits

PL= LL= PI=

Coefficients

D₈₅= D₆₀= D₅₀=
D₃₀= D₁₅= D₁₀=
C_u= C_c=

Classification

USCS= AASHTO=

Remarks

* (no specification provided)

Sample No.: B9 @ 3.0'
Location:

Source of Sample:

Date: 11/08/06
Elev./Depth: 3.0 feet



Client:
Project: Coast Recycled Water Pipeline - Marina, CA

Project No.: 7496.1.001.01

Particle Size Distribution Report

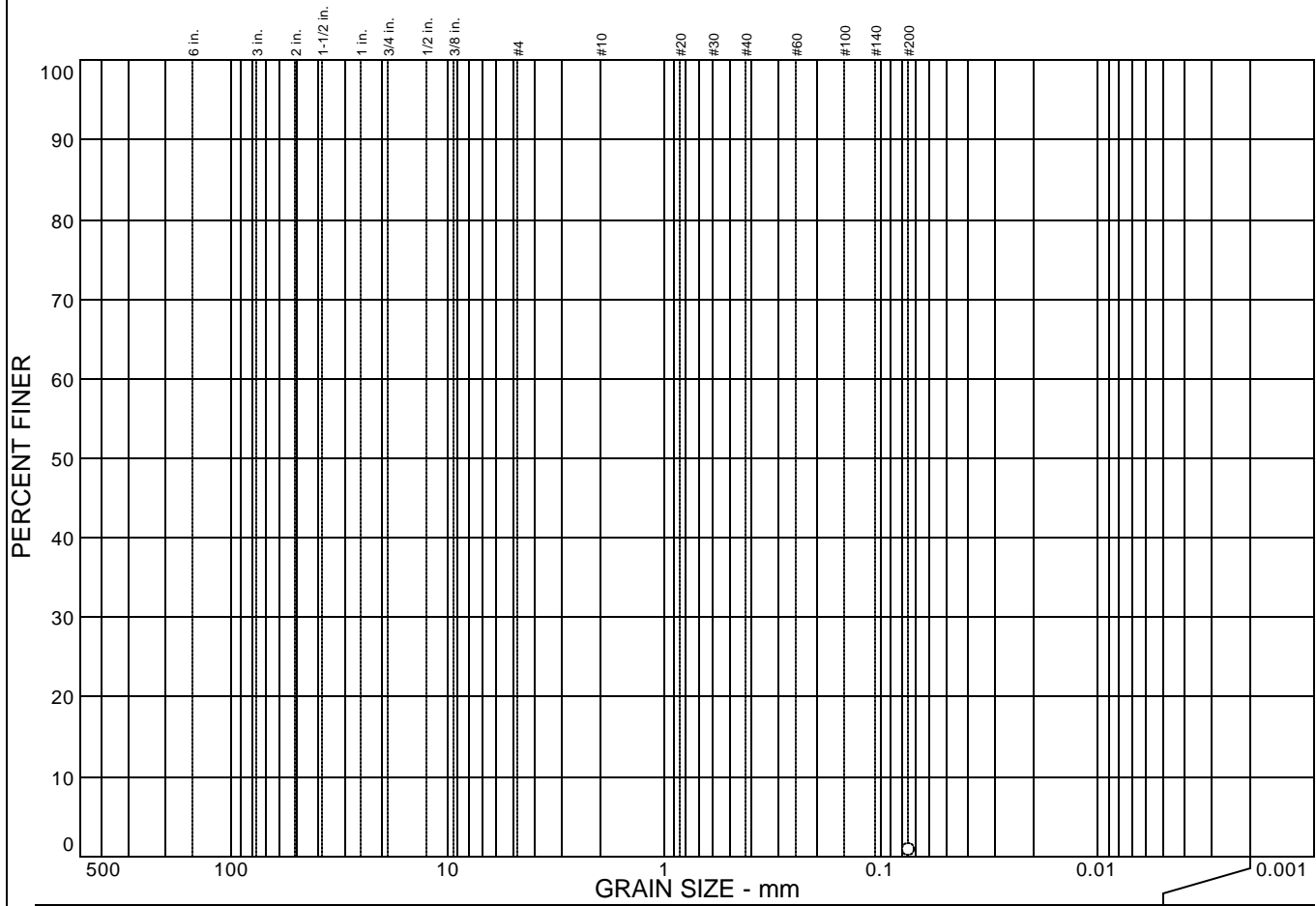

% COBBLES	% GRAVEL	% SAND	% SILT	% CLAY
			0.8	

SIEVE SIZE	PERCENT FINER	SPEC.* PERCENT	PASS? (X=NO)
#200	0.8		

Soil Description

Olive yellow SAND. Trace silt.

Atterberg Limits

PL= LL= PI=

Coefficients

D₈₅= D₆₀= D₅₀=
 D₃₀= D₁₅= D₁₀=
 C_u= C_c=

Classification

USCS= AASHTO=

Remarks

* (no specification provided)

Sample No.: B9 @ 5.5'
Location:

Source of Sample:

Date: 11/08/06
Elev./Depth: 5.5 feet



Client:
Project: Coast Recycled Water Pipeline - Marina, CA

Project No.: 7496.1.001.01

Particle Size Distribution Report

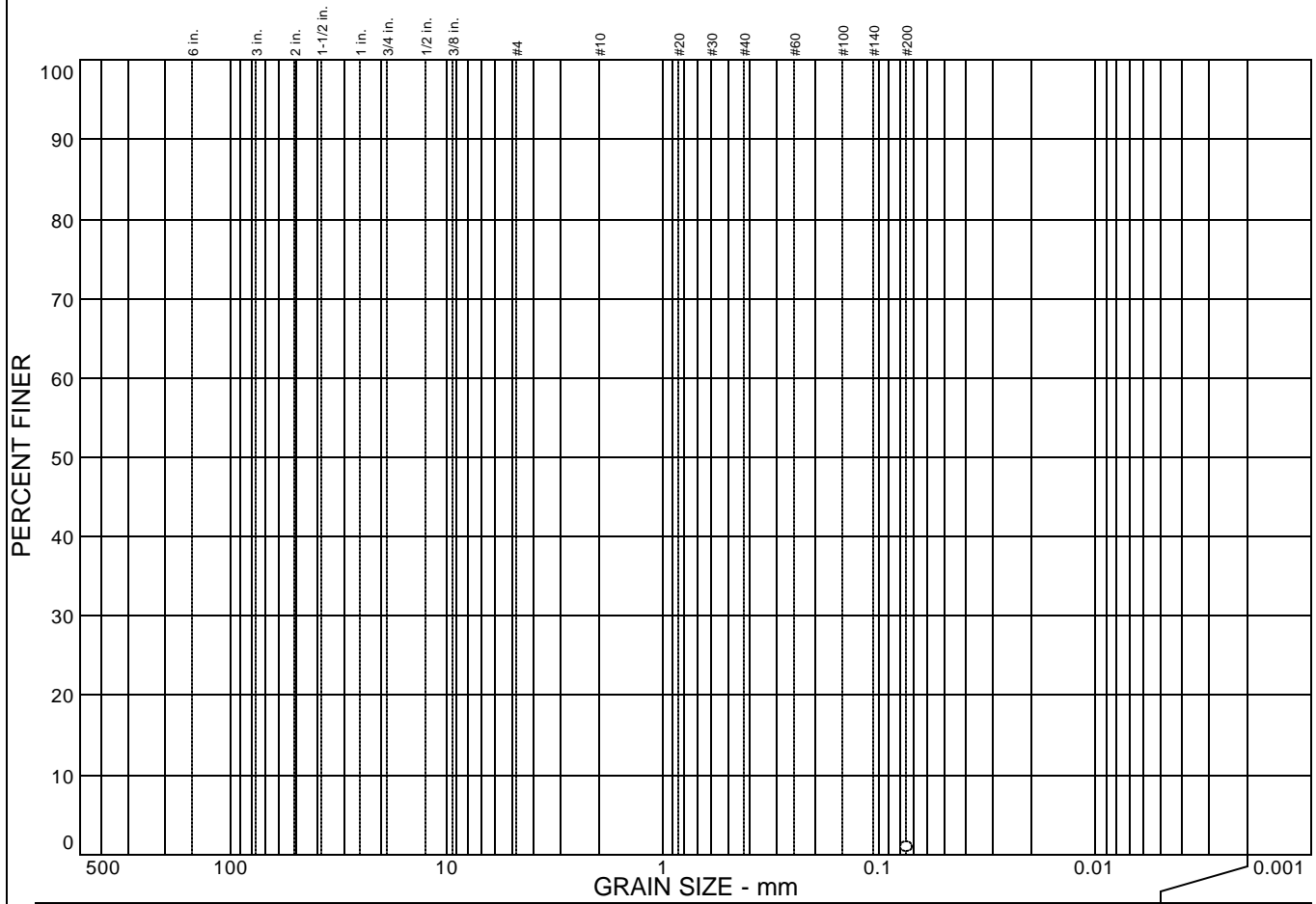

% COBBLES	% GRAVEL	% SAND	% SILT	% CLAY
			0.9	

SIEVE SIZE	PERCENT FINER	SPEC.* PERCENT	PASS? (X=NO)
#200	0.9		

Soil Description

Olive yellow SAND. Trace silt.

Atterberg Limits

PL= LL= PI=

Coefficients

D₈₅= D₆₀= D₅₀=
D₃₀= D₁₅= D₁₀=
C_u= C_c=

Classification

USCS= AASHTO=

Remarks

* (no specification provided)

Sample No.: B9 @ 7.5'
Location:

Source of Sample:

Date: 11/08/06
Elev./Depth: 7.5 feet



Client:
Project: Coast Recycled Water Pipeline - Marina, CA

Project No.: 7496.1.001.01

Particle Size Distribution Report

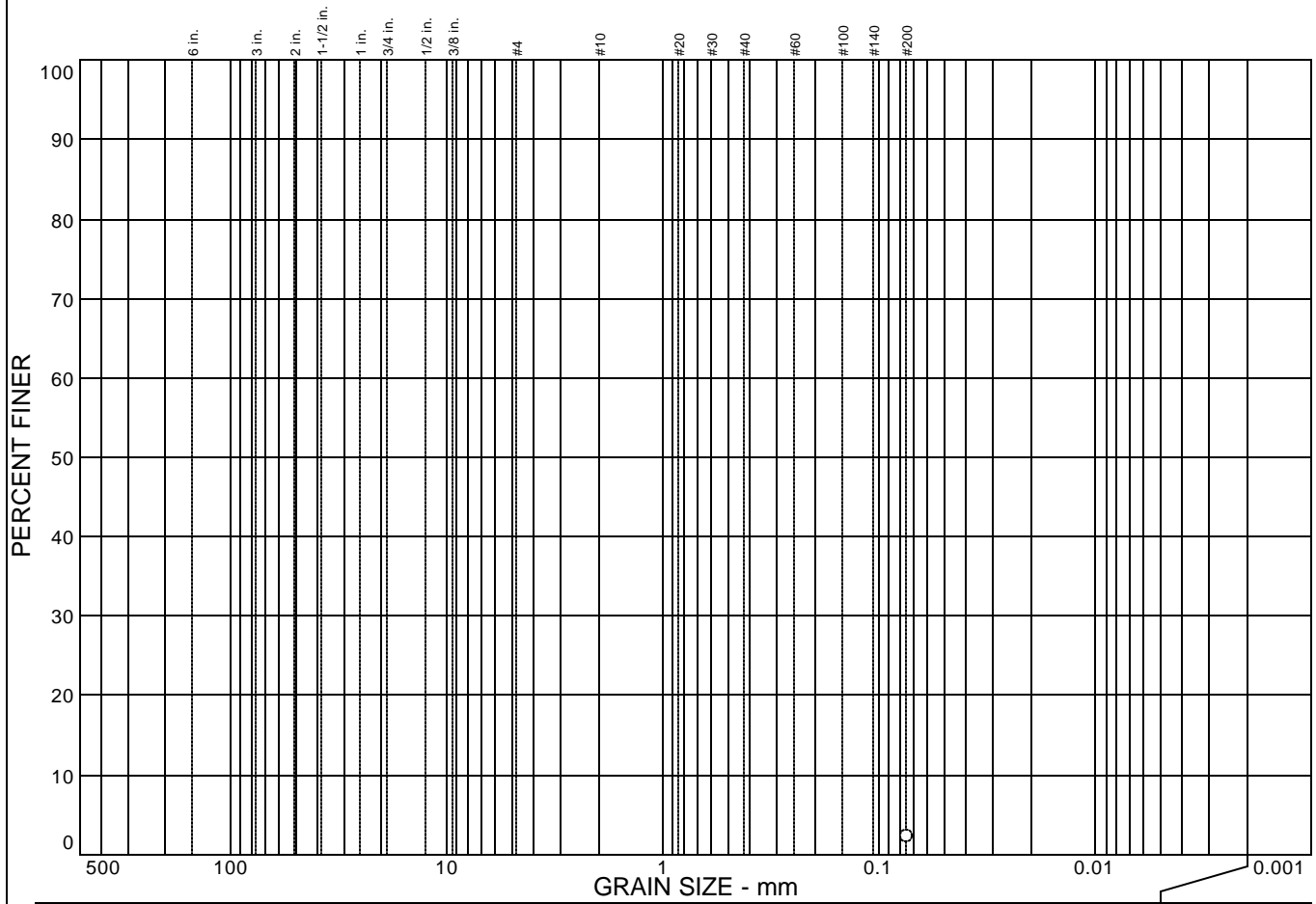

% COBBLES	% GRAVEL	% SAND	% SILT	% CLAY
			2.3	

SIEVE SIZE	PERCENT FINER	SPEC.* PERCENT	PASS? (X=NO)
#200	2.3		

Soil Description

Olive yellow SAND. Trace silt.

Atterberg Limits

PL= LL= PI=

Coefficients

D₈₅= D₆₀= D₅₀=
D₃₀= D₁₅= D₁₀=
C_u= C_c=

Classification

USCS= AASHTO=

Remarks

* (no specification provided)

Sample No.: B9 @ 11.0'
Location:

Source of Sample:

Date: 11/08/06
Elev./Depth: 11.0 feet



Client:
Project: Coast Recycled Water Pipeline - Marina, CA

Project No.: 7496.1.001.01

Particle Size Distribution Report

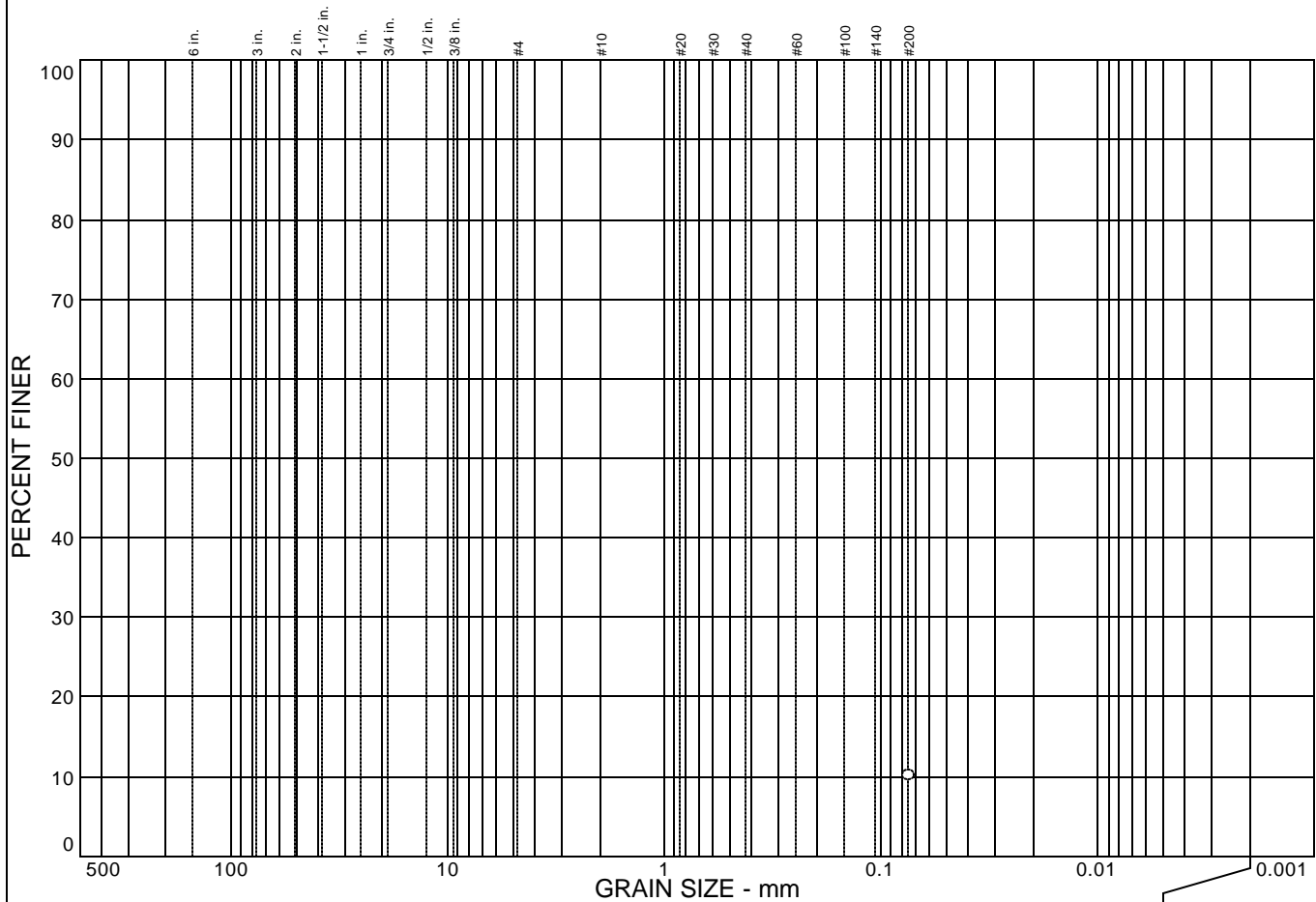

% COBBLES	% GRAVEL	% SAND	% SILT	% CLAY
			10.1	

SIEVE SIZE	PERCENT FINER	SPEC.* PERCENT	PASS? (X=NO)
#200	10.1		

Soil Description

Very dark brown SAND with some silt.

Atterberg Limits

PL= LL= PI=

Coefficients

D₈₅= D₆₀= D₅₀=
D₃₀= D₁₅= D₁₀=
C_u= C_c=

Classification

USCS= AASHTO=

Remarks

* (no specification provided)

Sample No.: B10 @ 3.0'
Location:

Source of Sample:

Date: 11/08/06
Elev./Depth: 3.0 feet



Client:
Project: Coast Recycled Water Pipeline - Marina, CA

Project No.: 7496.1.001.01

Particle Size Distribution Report

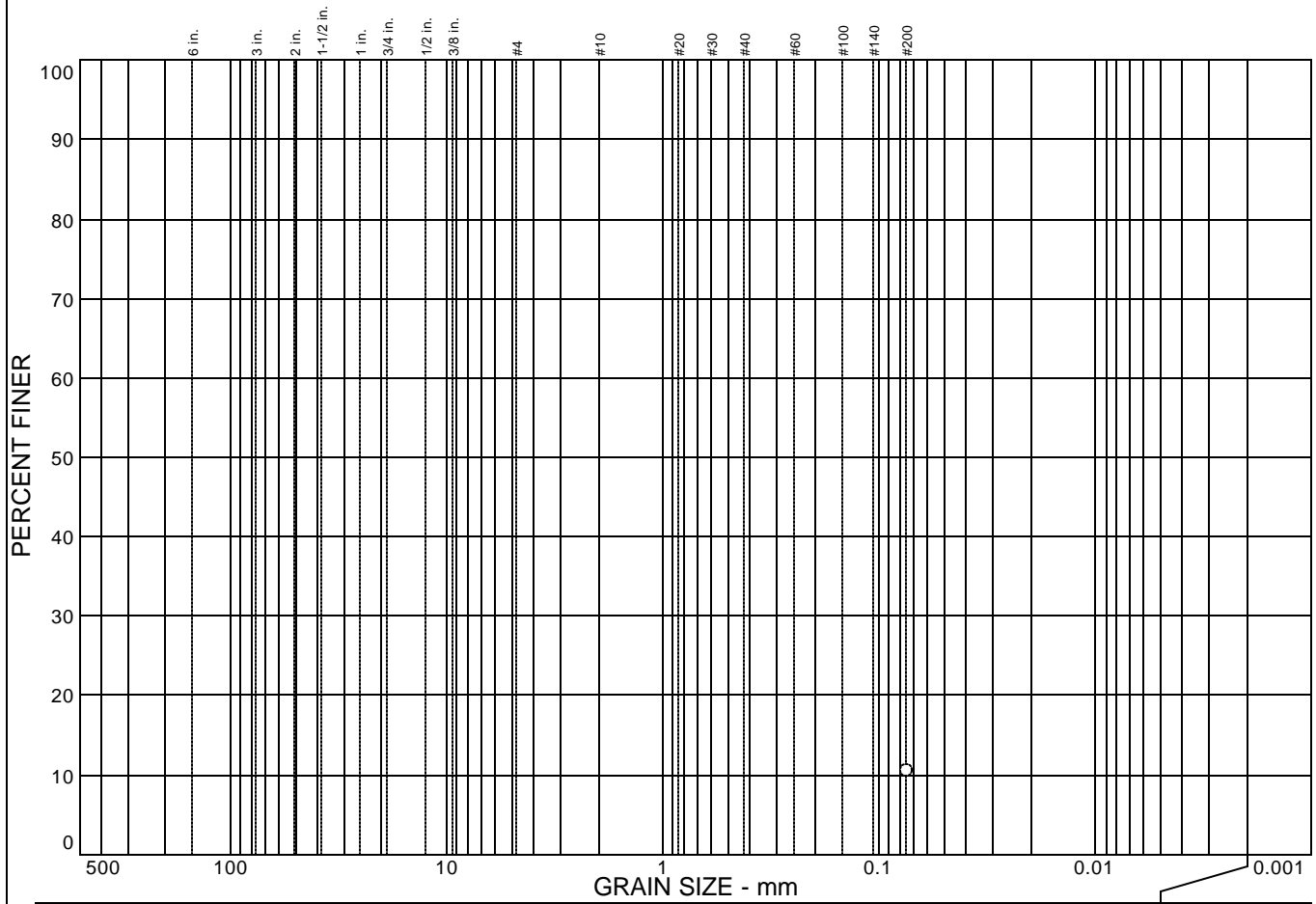

% COBBLES	% GRAVEL	% SAND	% SILT	% CLAY
			10.5	

SIEVE SIZE	PERCENT FINER	SPEC.* PERCENT	PASS? (X=NO)
#200	10.5		

Soil Description

Dark yellowish brown SAND with some silt.

Atterberg Limits

PL= LL= PI=

Coefficients

D₈₅= D₆₀= D₅₀=
D₃₀= D₁₅= D₁₀=
C_u= C_c=

Classification

USCS= AASHTO=

Remarks

* (no specification provided)

Sample No.: B10 @ 5.5'
Location:

Source of Sample:

Date: 11/08/06
Elev./Depth: 5.5 feet



Client:
Project: Coast Recycled Water Pipeline - Marina, CA
Project No.: 7496.1.001.01

Particle Size Distribution Report

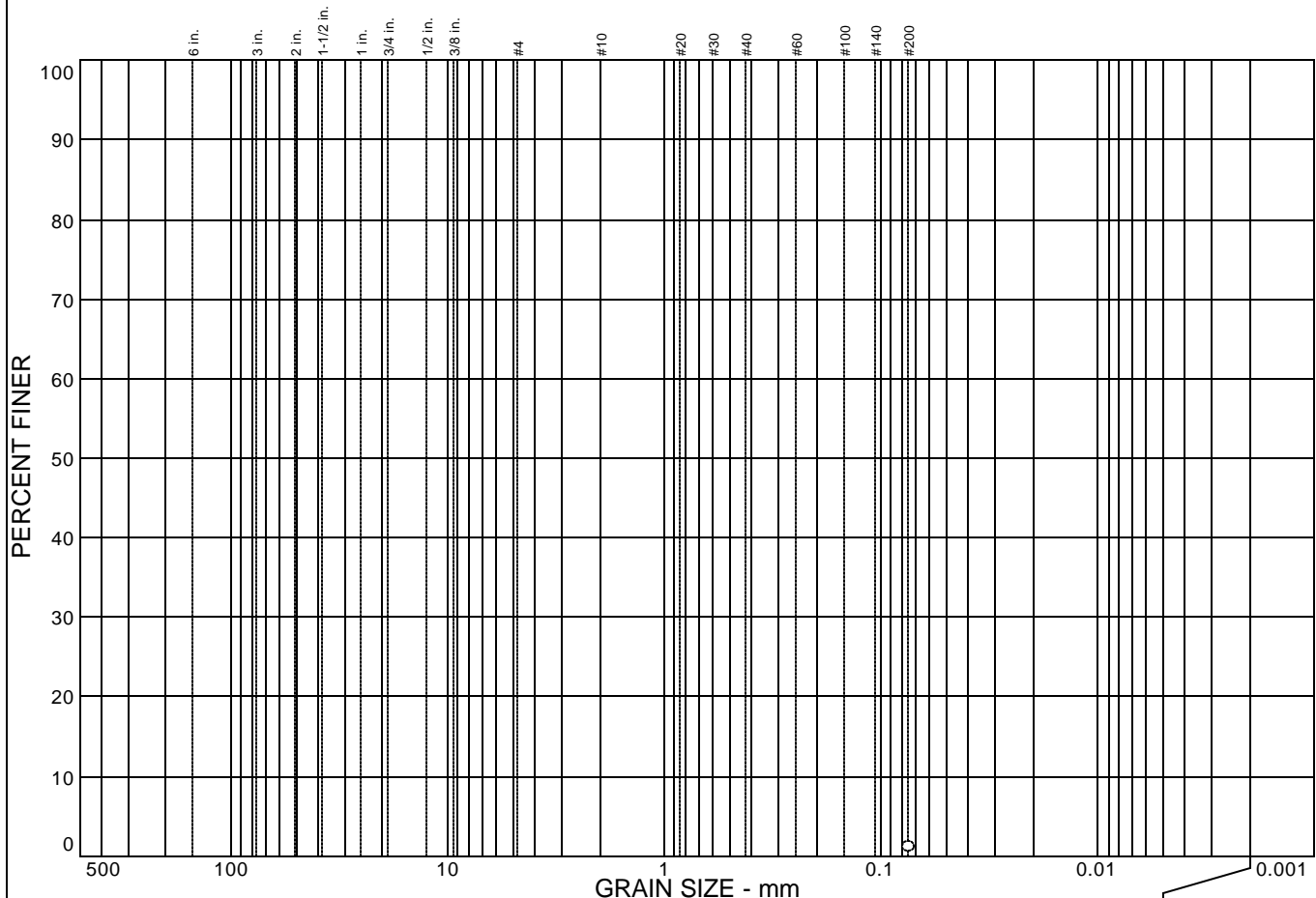

% COBBLES	% GRAVEL	% SAND	% SILT	% CLAY
			1.1	

SIEVE SIZE	PERCENT FINER	SPEC.* PERCENT	PASS? (X=NO)
#200	1.1		

Soil Description

Olive yellow SAND. Trace sand.

Atterberg Limits

PL= LL= PI=

Coefficients

D₈₅= D₆₀= D₅₀=
 D₃₀= D₁₅= D₁₀=
 C_u= C_c=

Classification

USCS= AASHTO=

Remarks

* (no specification provided)

Sample No.: B10 @ 7.5'
Location:

Source of Sample:

Date: 11/08/06
Elev./Depth: 7.5 feet



Client:
Project: Coast Recycled Water Pipeline - Marina, CA

Project No.: 7496.1.001.01

Particle Size Distribution Report

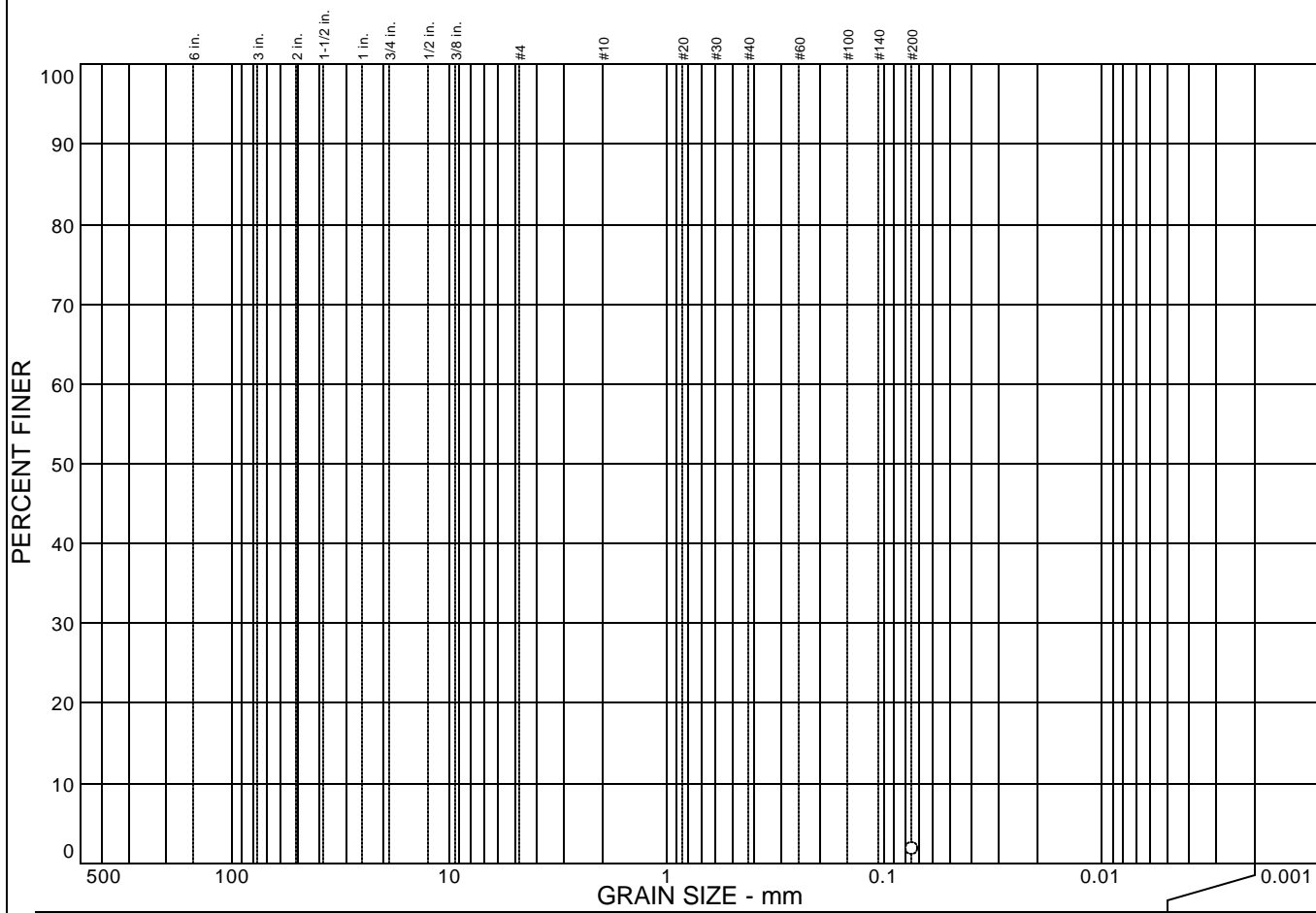

% COBBLES	% GRAVEL	% SAND	% SILT	% CLAY
			1.8	

SIEVE SIZE	PERCENT FINER	SPEC.* PERCENT	PASS? (X=NO)
#200	1.8		

Soil Description

Olive yellow SAND. Trace silt.

Atterberg Limits

PL= LL= PI=

Coefficients

D₈₅= D₆₀= D₅₀=
 D₃₀= D₁₅= D₁₀=
 C_u= C_c=

Classification

USCS= AASHTO=

Remarks

* (no specification provided)

Sample No.: B10 @ 13.0' **Source of Sample:** **Date:** 11/08/06
Location: **Elev./Depth:** 13.0 feet

Particle Size Distribution Report

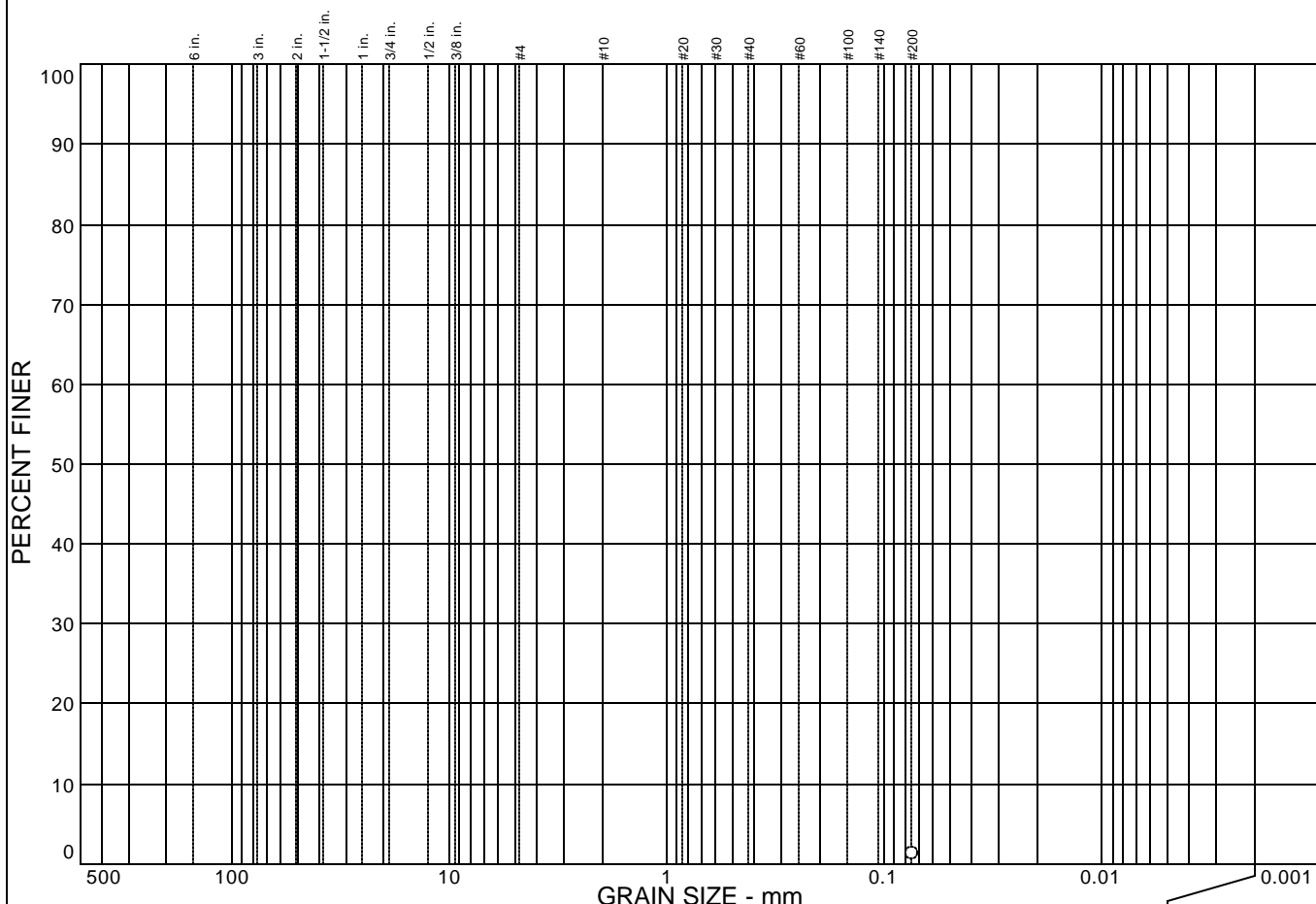

% COBBLES	% GRAVEL	% SAND	% SILT	% CLAY
			1.2	

SIEVE SIZE	PERCENT FINER	SPEC.* PERCENT	PASS? (X=NO)
#200	1.2		

Soil Description

Olive yellow SAND. trace silt.

Atterberg Limits

PL= LL= PI=

Coefficients

D₈₅= D₆₀= D₅₀=
D₃₀= D₁₅= D₁₀=
C_u= C_c=

Classification

USCS= AASHTO=

Remarks

* (no specification provided)

Sample No.: B11 @ 3.0'
Location:

Source of Sample:

Date: 11/08/06
Elev./Depth: 3.0 feet



Client:
Project: Coast Recycled Water Pipeline - Marina, CA

Project No.: 7496.1.001.01

Particle Size Distribution Report

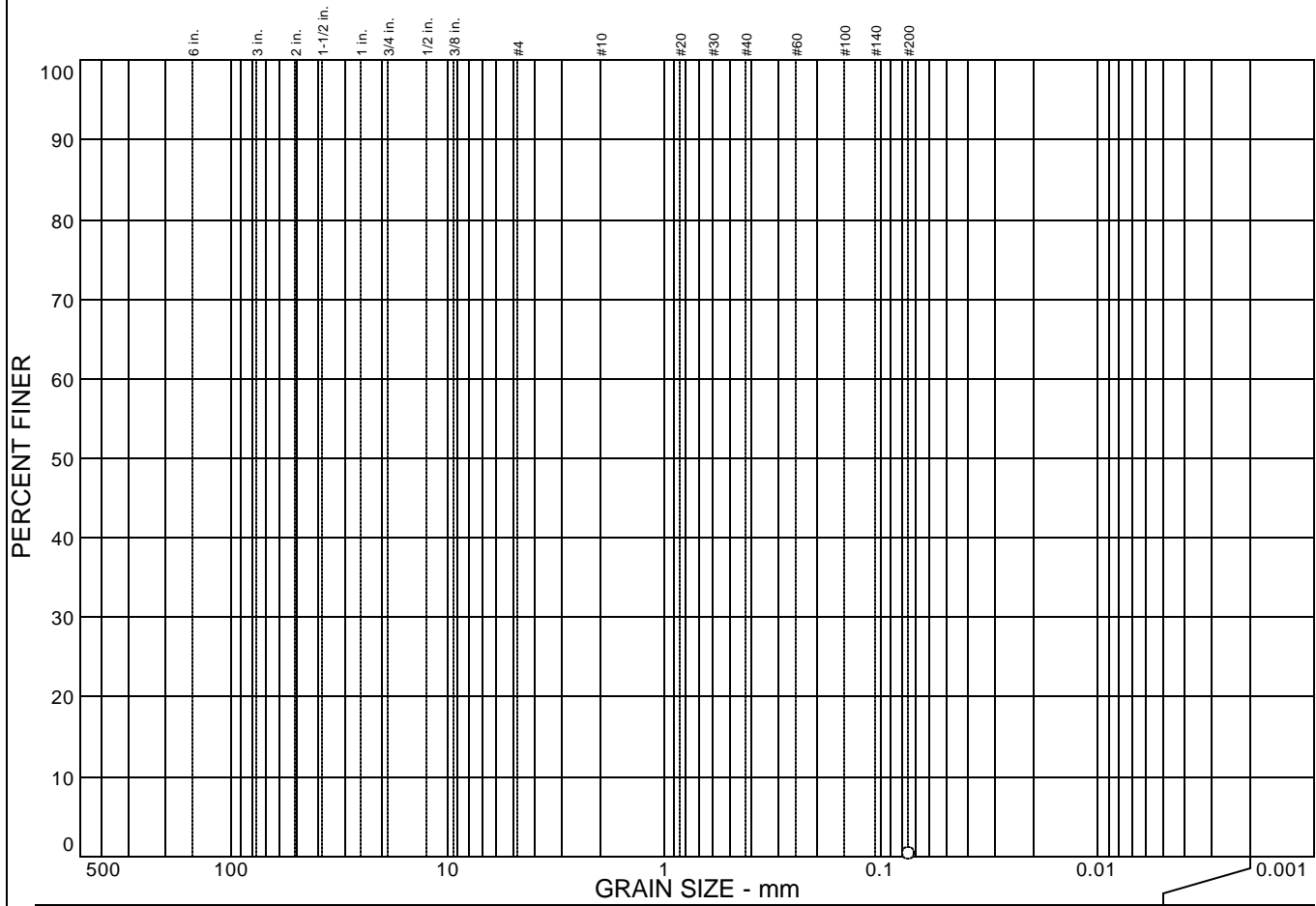

% COBBLES	% GRAVEL	% SAND	% SILT	% CLAY
			0.3	

SIEVE SIZE	PERCENT FINER	SPEC.* PERCENT	PASS? (X=NO)
#200	0.3		

Soil Description

Olive yellow SAND.

Atterberg Limits

PL= LL= PI=

Coefficients

D₈₅= D₆₀= D₅₀=
 D₃₀= D₁₅= D₁₀=
 C_u= C_c=

Classification

USCS= AASHTO=

Remarks

* (no specification provided)

Sample No.: B11 @ 5.5'
Location:

Source of Sample:

Date: 11/08/06
Elev./Depth: 5.5 feet



Client:
Project: Coast Recycled Water Pipeline - Marina, CA

Project No.: 7496.1.001.01

Particle Size Distribution Report

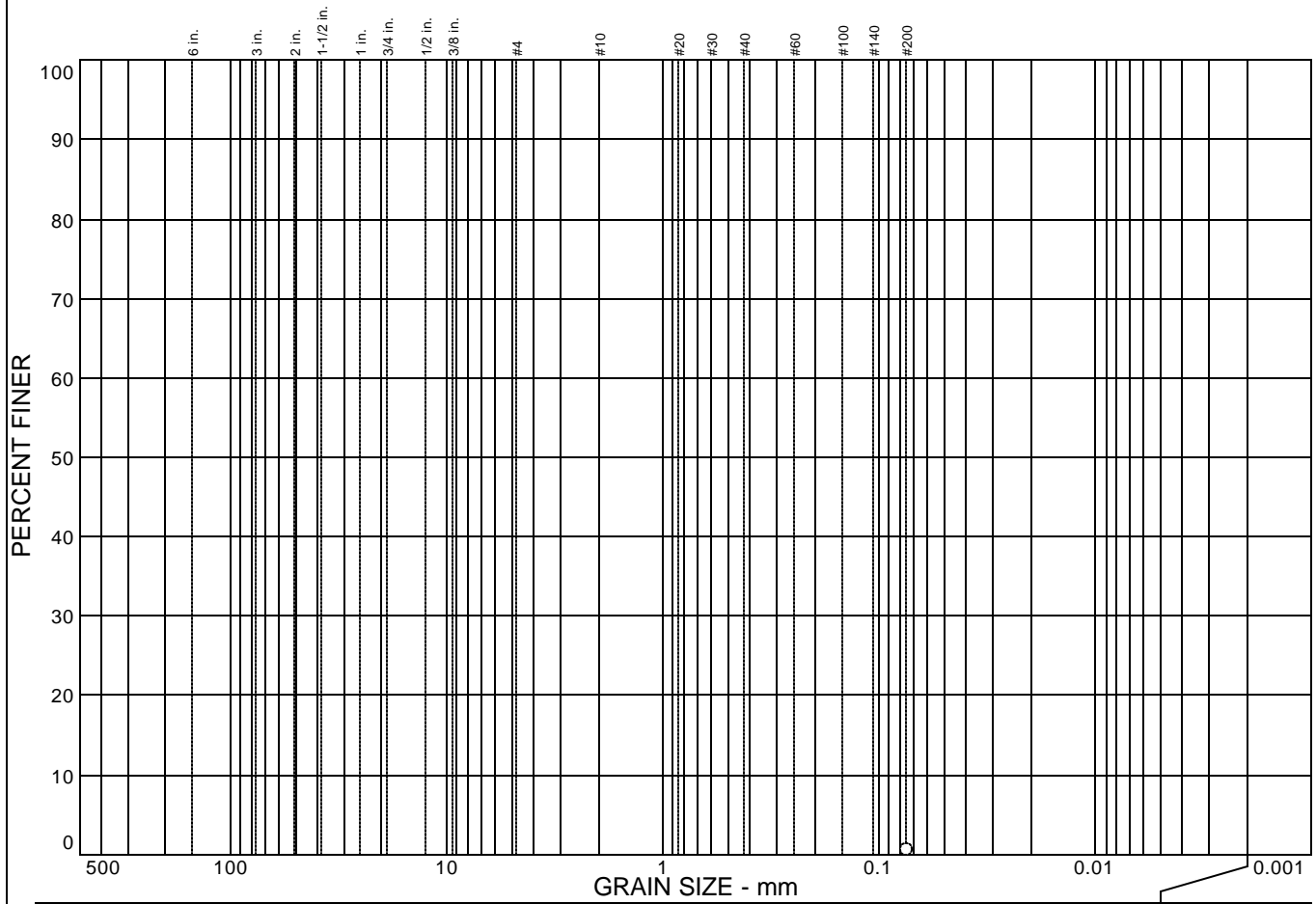

% COBBLES	% GRAVEL	% SAND	% SILT	% CLAY
			0.6	

SIEVE SIZE	PERCENT FINER	SPEC.* PERCENT	PASS? (X=NO)
#200	0.6		

Soil Description

Olive yellow SAND.

Atterberg Limits

PL= LL= PI=

Coefficients

D₈₅= D₆₀= D₅₀=
 D₃₀= D₁₅= D₁₀=
 C_u= C_c=

Classification

USCS= AASHTO=

Remarks

* (no specification provided)

Sample No.: B11 @ 7.5'
Location:

Source of Sample:

Date: 11/08/06
Elev./Depth: 7.5 feet



Client:
Project: Coast Recycled Water Pipeline - Marina, CA

Project No.: 7496.1.001.01

Particle Size Distribution Report

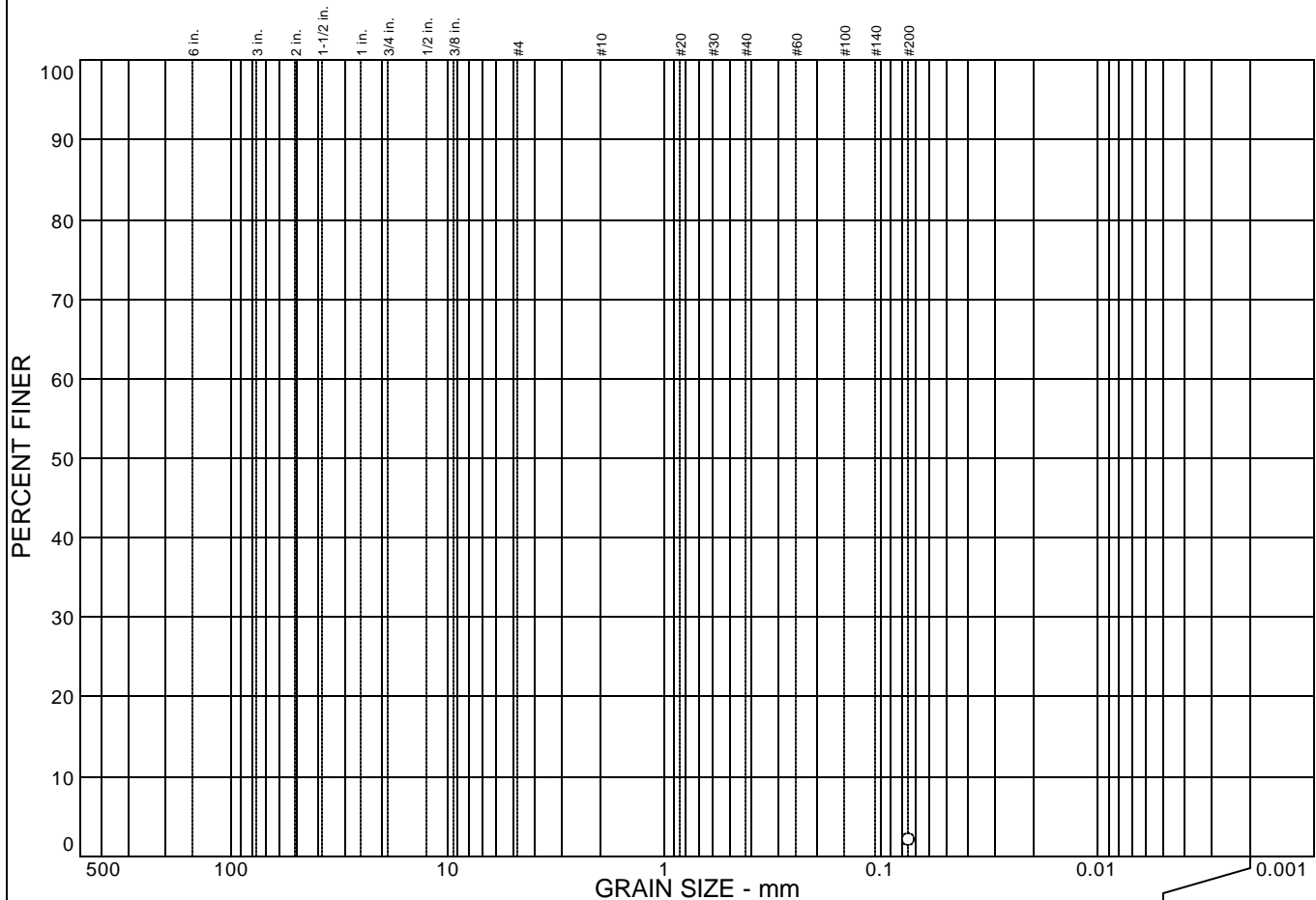

% COBBLES	% GRAVEL	% SAND	% SILT	% CLAY
			2.0	

SIEVE SIZE	PERCENT FINER	SPEC.* PERCENT	PASS? (X=NO)
#200	2.0		

Soil Description

Light yellowish brown SAND. Trace silt.

Atterberg Limits

PL= LL= PI=

Coefficients

D₈₅= D₆₀= D₅₀=
D₃₀= D₁₅= D₁₀=
C_u= C_c=

Classification

USCS= AASHTO=

Remarks

* (no specification provided)

Sample No.: B12 @ 3.0'
Location:

Source of Sample:

Date: 11/09/06
Elev./Depth: 3.0 feet



Client:
Project: Marina Coast Recycled Water Pipeline - Marina, CA

Project No.: 7496.1.001.01

Particle Size Distribution Report

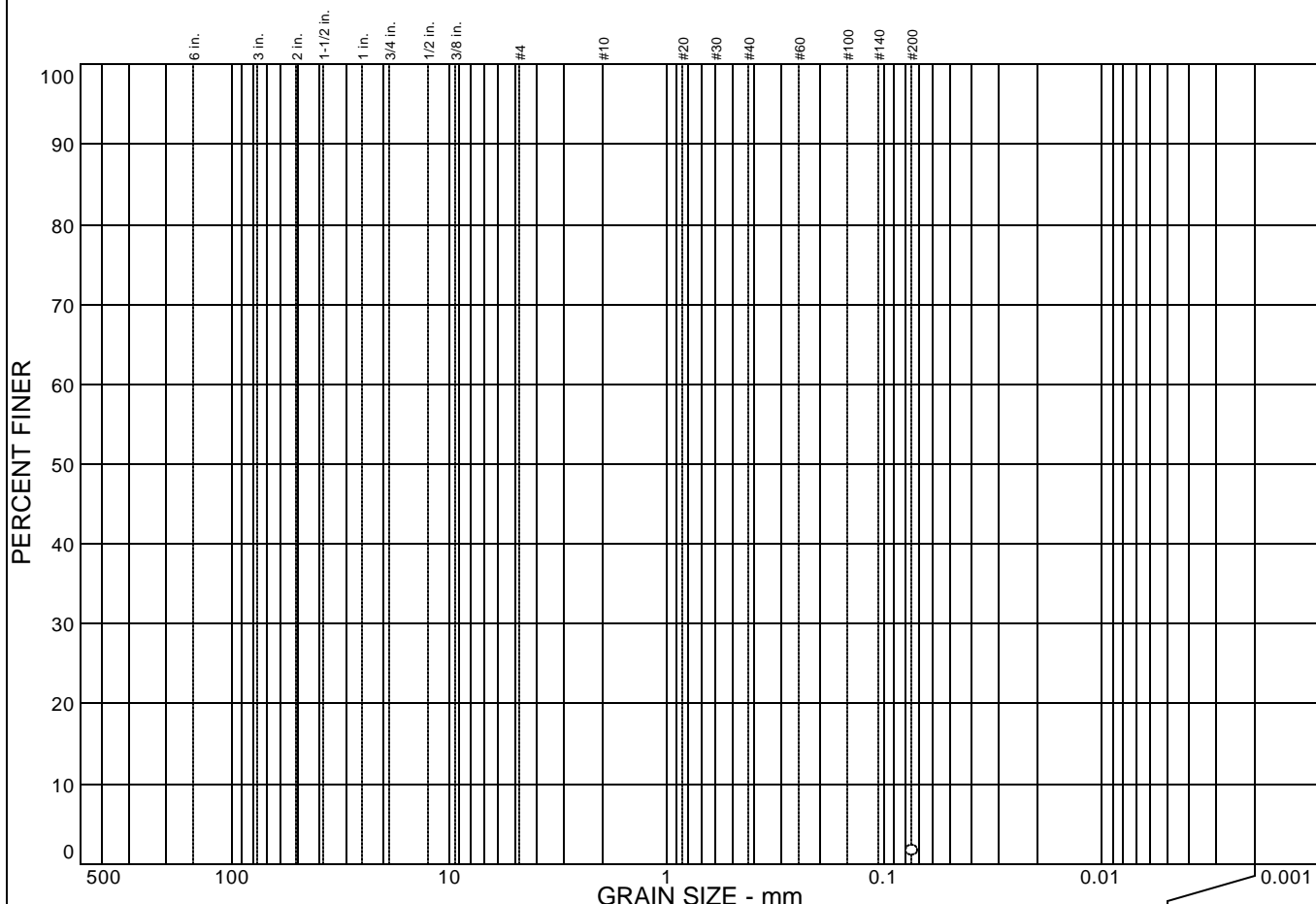

% COBBLES	% GRAVEL	% SAND	% SILT	% CLAY
			1.6	

SIEVE SIZE	PERCENT FINER	SPEC.* PERCENT	PASS? (X=NO)
#200	1.6		

Soil Description

Light yellowish brown SAND. Trace silt.

Atterberg Limits

PL= LL= PI=

Coefficients

D₈₅= D₆₀= D₅₀=
D₃₀= D₁₅= D₁₀=
C_u= C_c=

Classification

USCS= AASHTO=

Remarks

* (no specification provided)

Sample No.: B12 @ 6.0'
Location:

Source of Sample:

Date: 11/09/06
Elev./Depth: 6.0 feet



Client:
Project: Marina Coast Recycled Water Pipeline - Marina, CA

Project No.: 7496.1.001.01

Particle Size Distribution Report

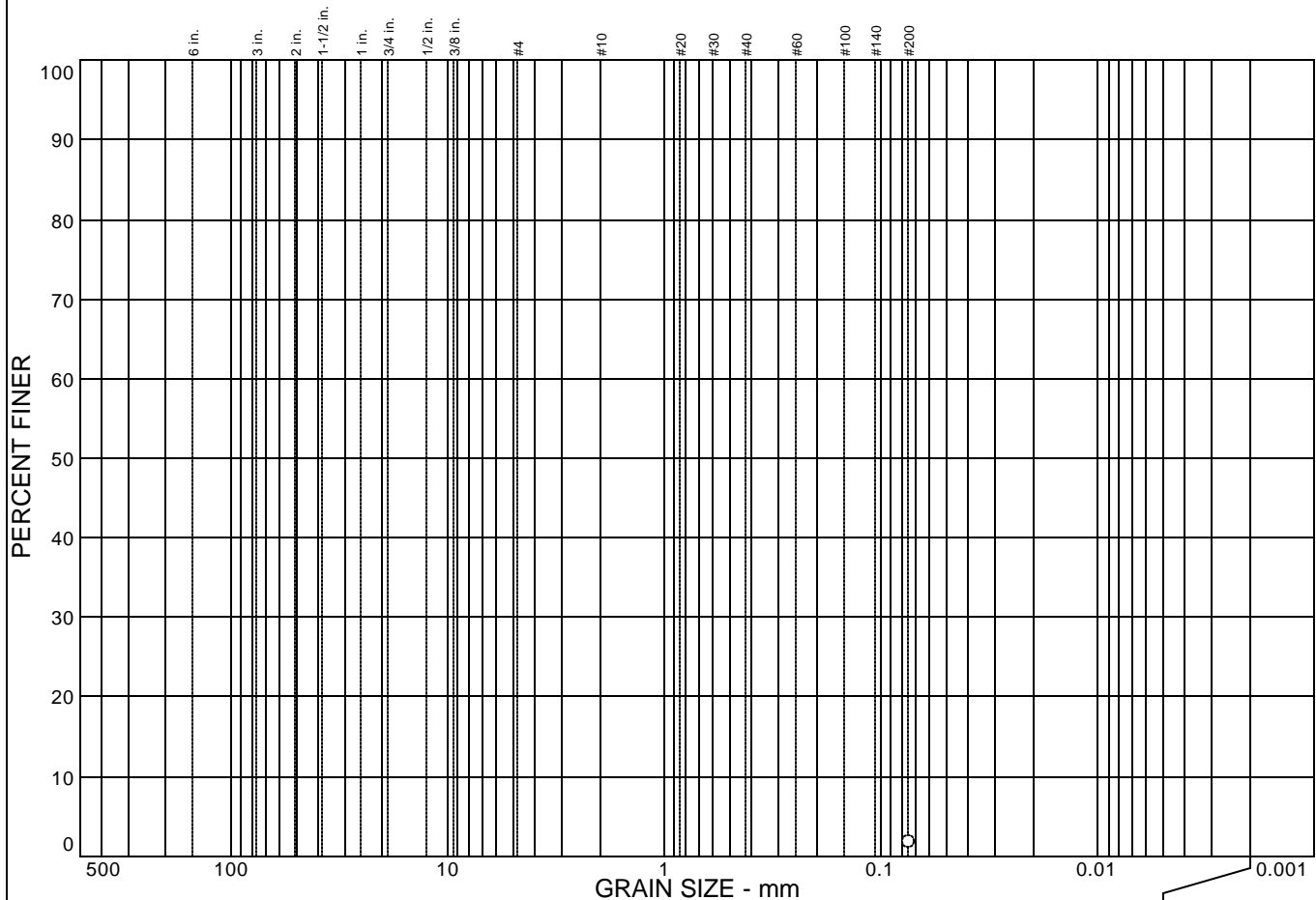

% COBBLES	% GRAVEL	% SAND	% SILT	% CLAY
			1.7	

SIEVE SIZE	PERCENT FINER	SPEC.* PERCENT	PASS? (X=NO)
#200	1.7		

Soil Description

Light yellowish brown SAND. Trace silt.

Atterberg Limits

PL= LL= PI=

Coefficients

D₈₅= D₆₀= D₅₀=
D₃₀= D₁₅= D₁₀=
C_u= C_c=

Classification

USCS= AASHTO=

Remarks

* (no specification provided)

Sample No.: B12 @ 11.0'
Location:

Source of Sample:

Date: 11/09/06
Elev./Depth: 11.0 feet



Client:
Project: Marina Coast Recycled Water Pipeline - Marina, CA

Project No.: 7496.1.001.01

Particle Size Distribution Report

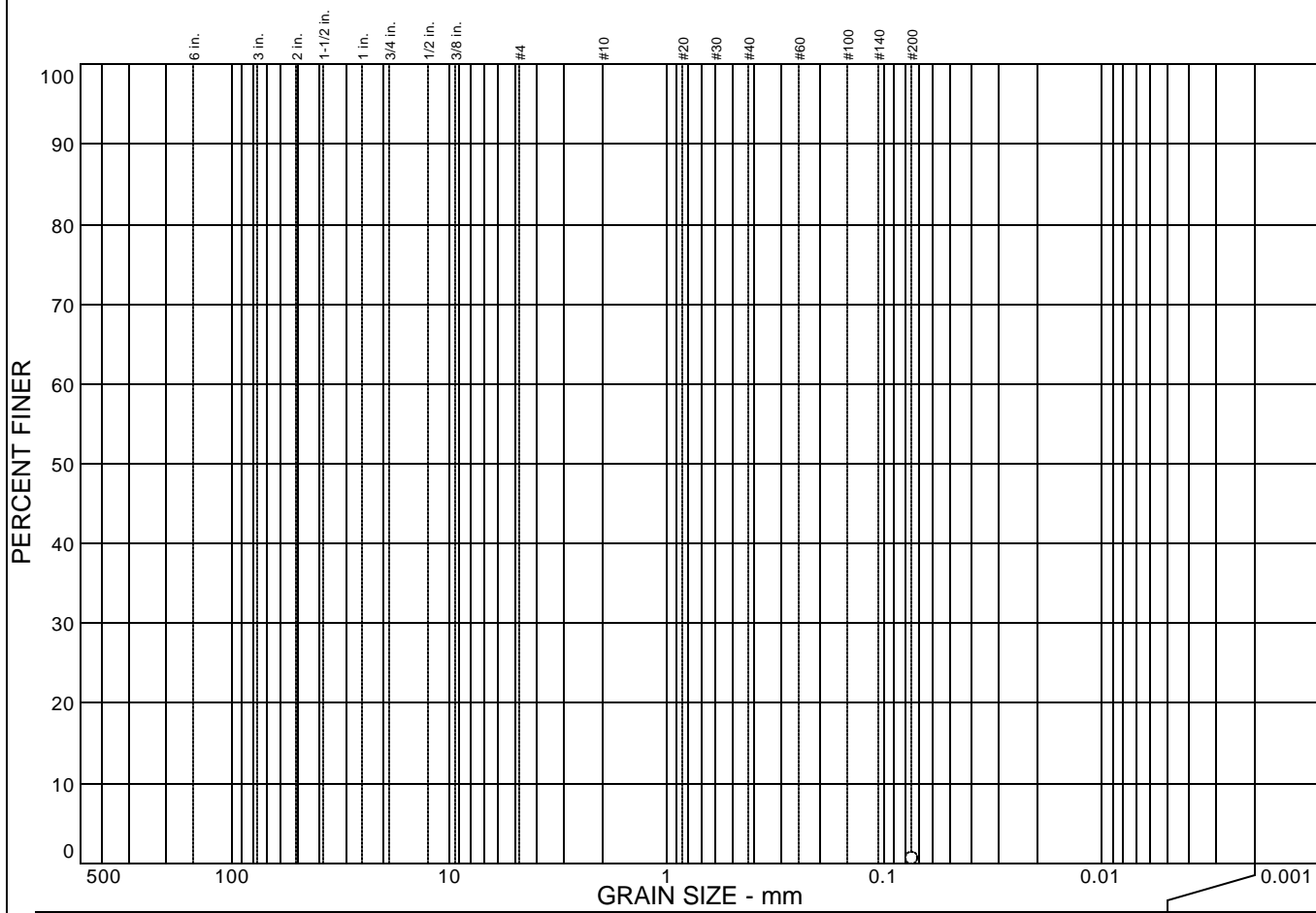

% COBBLES	% GRAVEL	% SAND	% SILT	% CLAY
			0.6	

SIEVE SIZE	PERCENT FINER	SPEC.* PERCENT	PASS? (X=NO)
#200	0.6		

Soil Description
Yellow SAND.

Atterberg Limits
 PL= LL= PI=

Coefficients
 D₈₅= D₆₀= D₅₀=
 D₃₀= D₁₅= D₁₀=
 C_u= C_c=

Classification
 USCS= AASHTO=

Remarks

* (no specification provided)

Sample No.: B13 @ 3.0' **Source of Sample:** **Date:** 11/09/06
Location: **Elev./Depth:** 3.0 feet

Particle Size Distribution Report

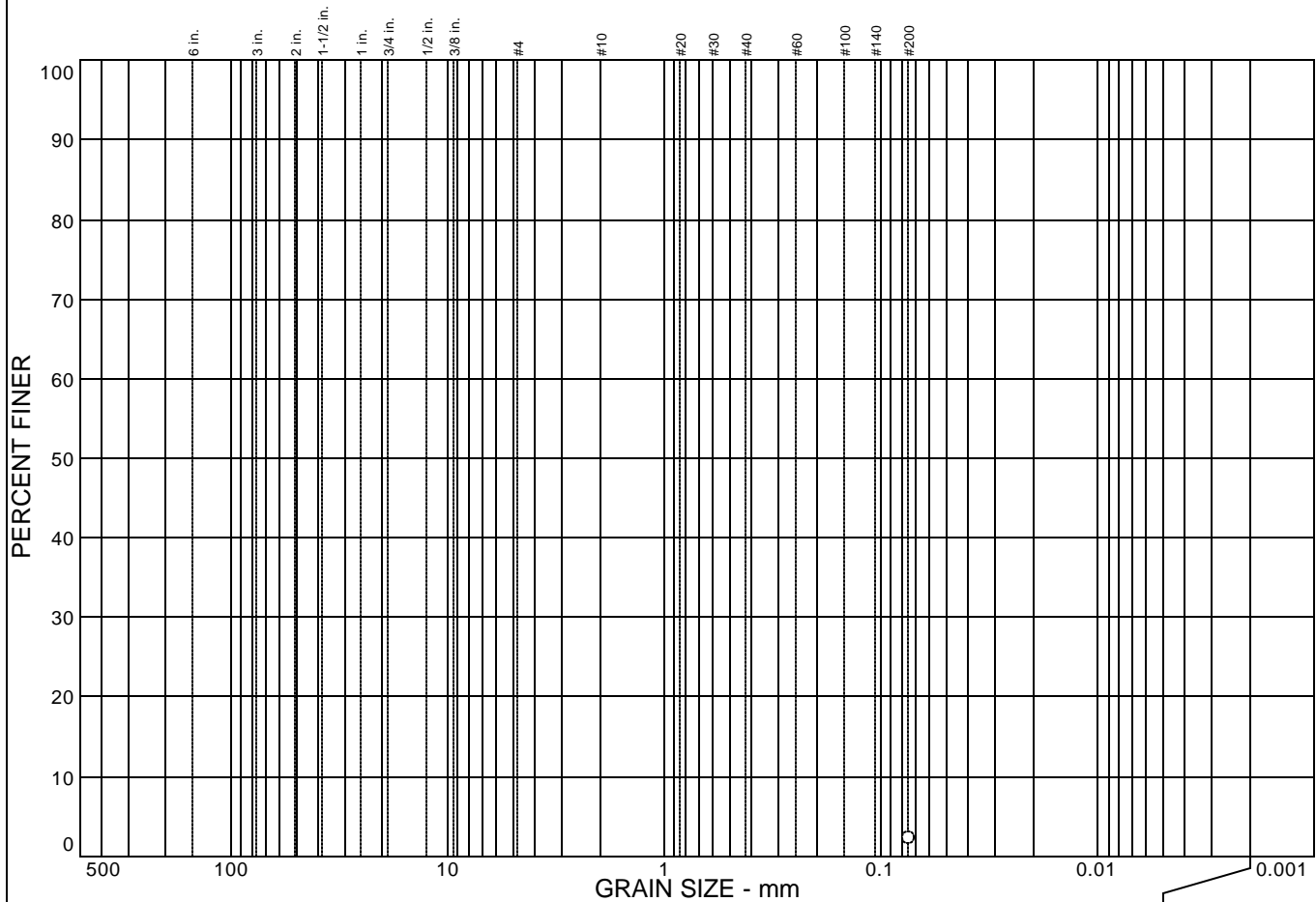

% COBBLES	% GRAVEL	% SAND	% SILT	% CLAY
			2.2	

SIEVE SIZE	PERCENT FINER	SPEC.* PERCENT	PASS? (X=NO)
#200	2.2		

Soil Description

Yellow medium to coarse SAND. Trace silt.

Atterberg Limits

PL= LL= PI=

Coefficients

D₈₅= D₆₀= D₅₀=
 D₃₀= D₁₅= D₁₀=
 C_u= C_c=

Classification

USCS= AASHTO=

Remarks

* (no specification provided)

Sample No.: B13 @ 8.0'
Location:

Source of Sample:

Date: 11/09/06
Elev./Depth: 8.0 feet



Client:
Project: Marina Coast Recycled Water Pipeline - Marina, CA

Project No.: 7496.1.001.01

Particle Size Distribution Report

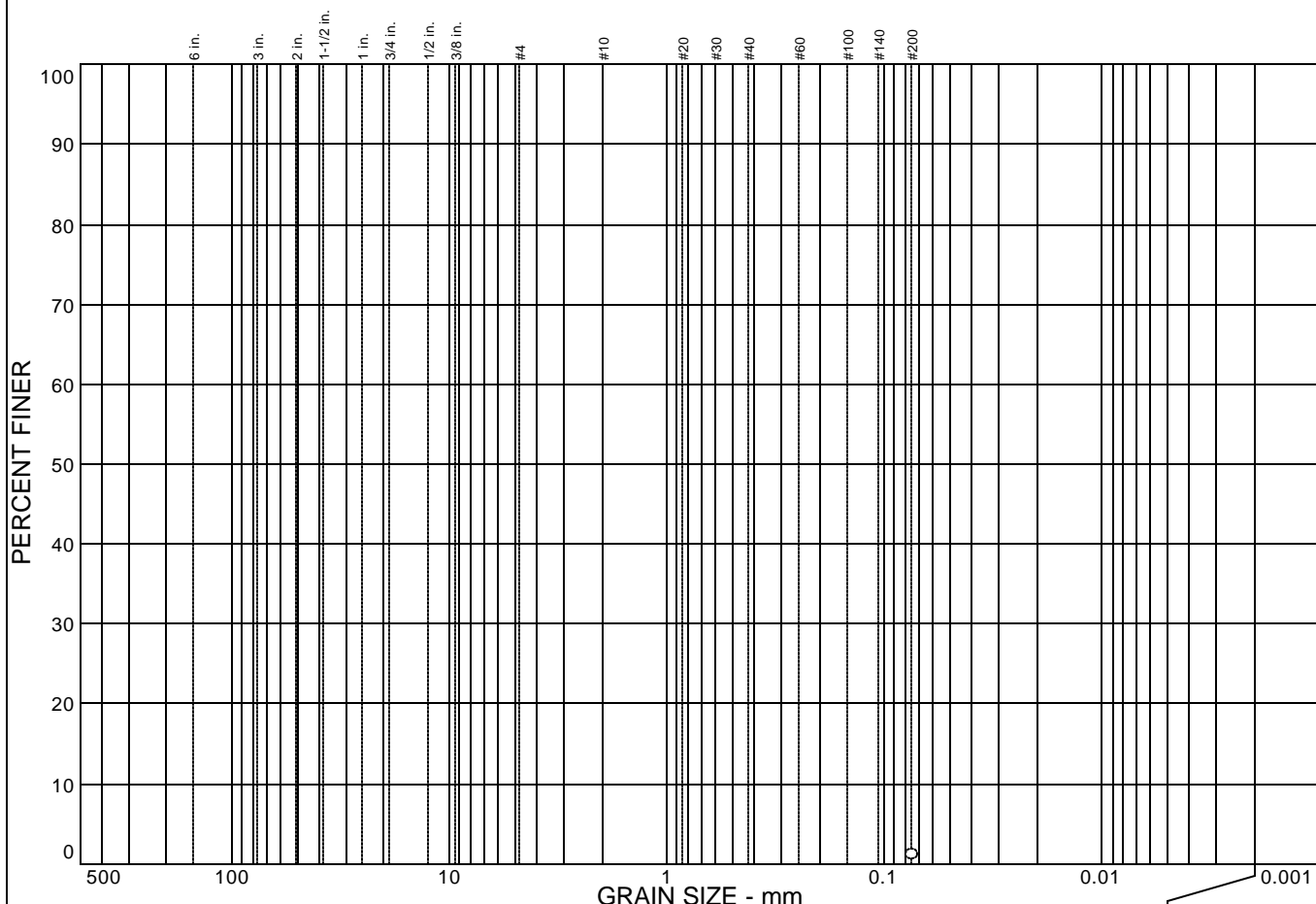

% COBBLES	% GRAVEL	% SAND	% SILT	% CLAY
			1.1	

SIEVE SIZE	PERCENT FINER	SPEC.* PERCENT	PASS? (X=NO)
#200	1.1		

Soil Description

Yellow medium to coarse SAND.

Atterberg Limits

PL= LL= PI=

Coefficients

D₈₅= D₆₀= D₅₀=
 D₃₀= D₁₅= D₁₀=
 C_u= C_c=

Classification

USCS= AASHTO=

Remarks

* (no specification provided)

Sample No.: B13 @ 11.0'
Location:

Source of Sample:

Date: 11/09/06
Elev./Depth: 11.0 feet



Client:
Project: Marina Coast Recycled Water Pipeline - Marina, CA
Project No.: 7496.1.001.01

Particle Size Distribution Report

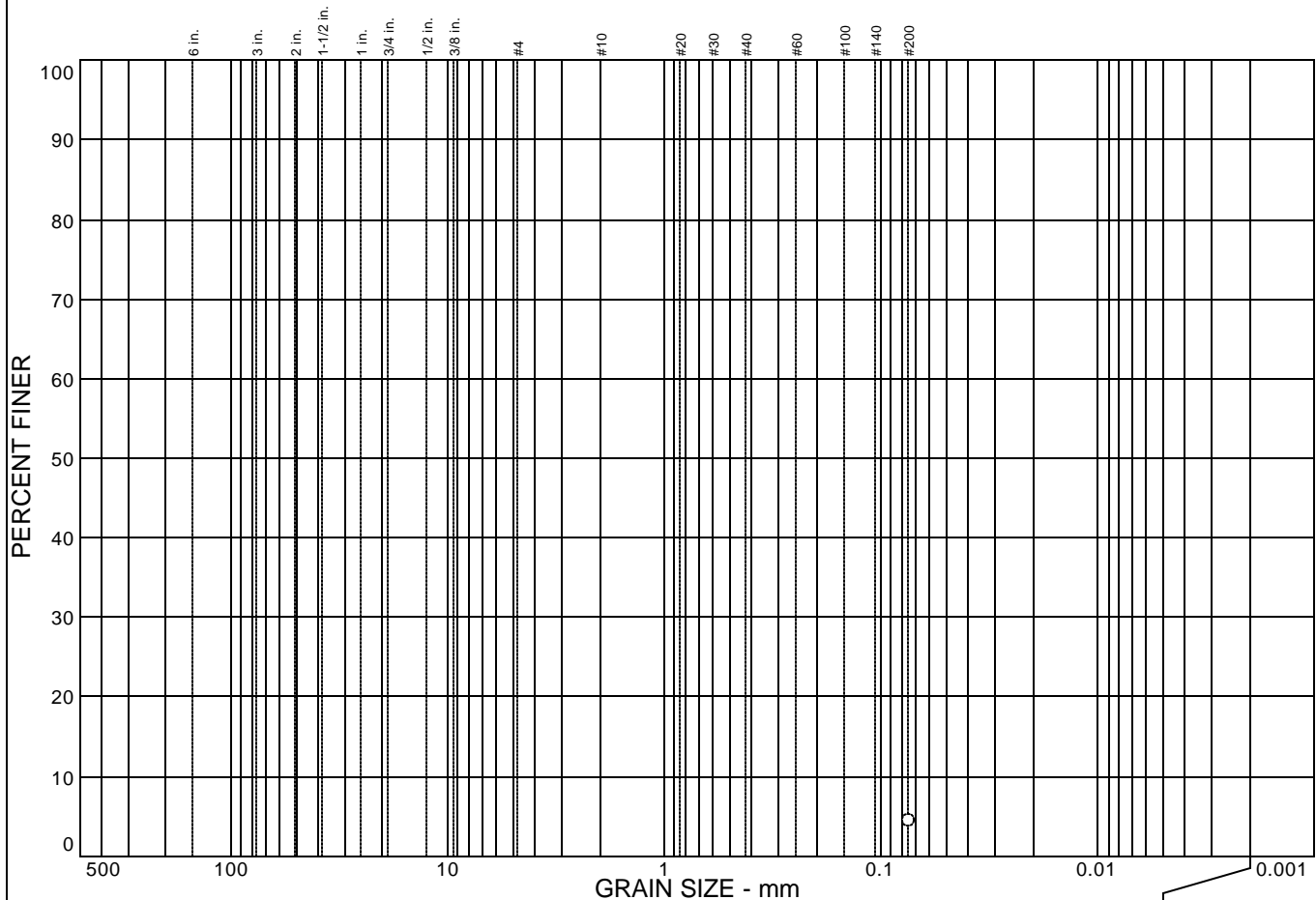

% COBBLES	% GRAVEL	% SAND	% SILT	% CLAY
			4.4	

SIEVE SIZE	PERCENT FINER	SPEC.* PERCENT	PASS? (X=NO)
#200	4.4		

Soil Description

Reddish brown SAND. Trace silt.

Atterberg Limits

PL= LL= PI=

Coefficients

D₈₅= D₆₀= D₅₀=
D₃₀= D₁₅= D₁₀=
C_u= C_c=

Classification

USCS= AASHTO=

Remarks

* (no specification provided)

Sample No.: B14 @ 3.0'
Location:

Source of Sample:

Date: 11/09/06
Elev./Depth: 3.0 feet



Client:
Project: Marina Coast Recycled Water Pipeline - Marina, CA

Project No.: 7496.1.001.01

Particle Size Distribution Report

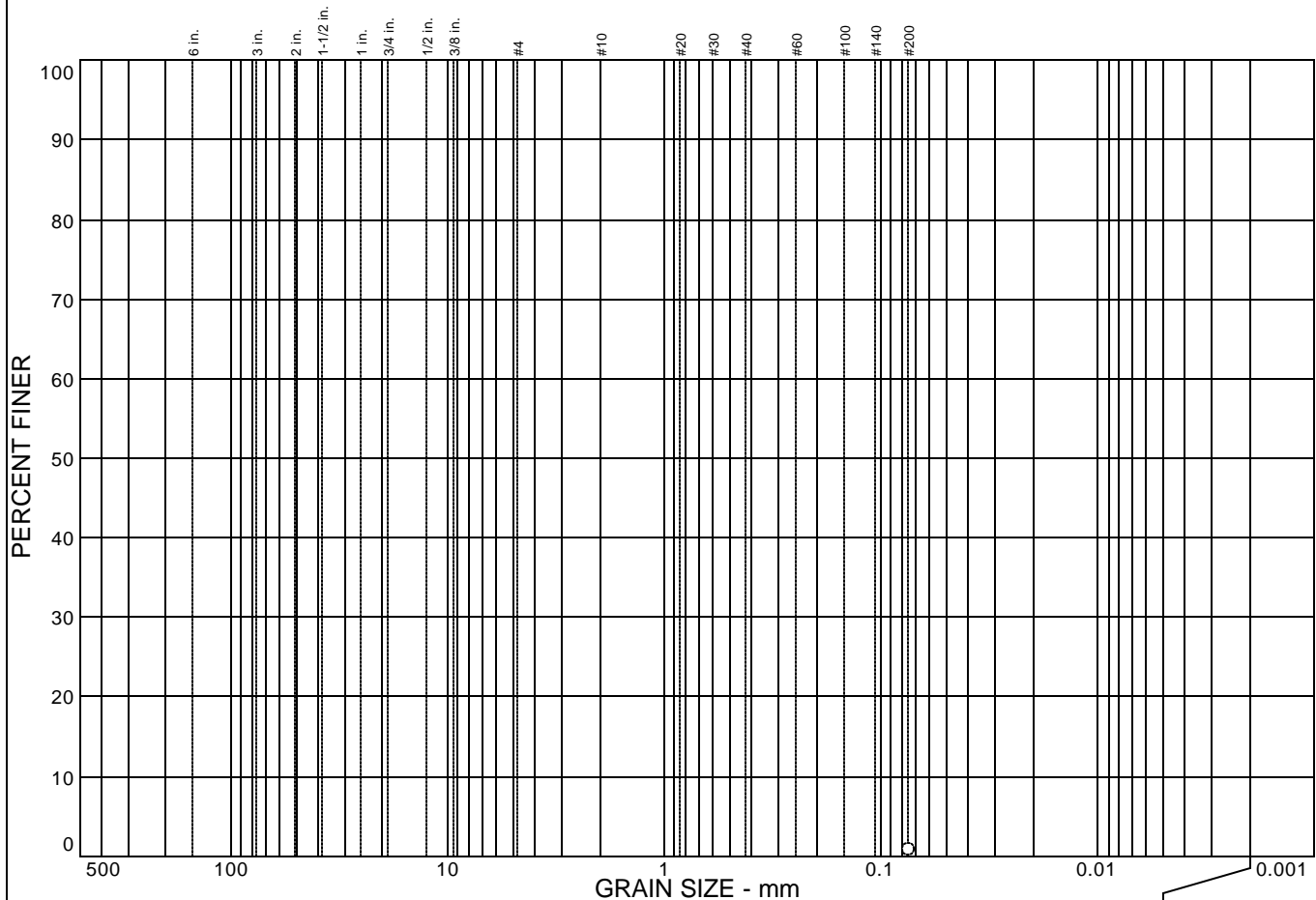

% COBBLES	% GRAVEL	% SAND	% SILT	% CLAY
			0.8	

SIEVE SIZE	PERCENT FINER	SPEC.* PERCENT	PASS? (X=NO)
#200	0.8		

Soil Description
Yellow SAND.

Atterberg Limits
 PL= LL= PI=
 D₈₅= D₆₀= D₅₀=
 D₃₀= D₁₅= D₁₀=
 C_u= C_c=

Classification
 USCS= AASHTO=

Remarks

* (no specification provided)

Sample No.: B14 @ 6.0'
Location:

Source of Sample:

Date: 11/09/06
Elev./Depth: 6.0 feet



Client:
Project: Marina Coast Recycled Water Pipeline - Marina, CA

Project No.: 7496.1.001.01

Particle Size Distribution Report

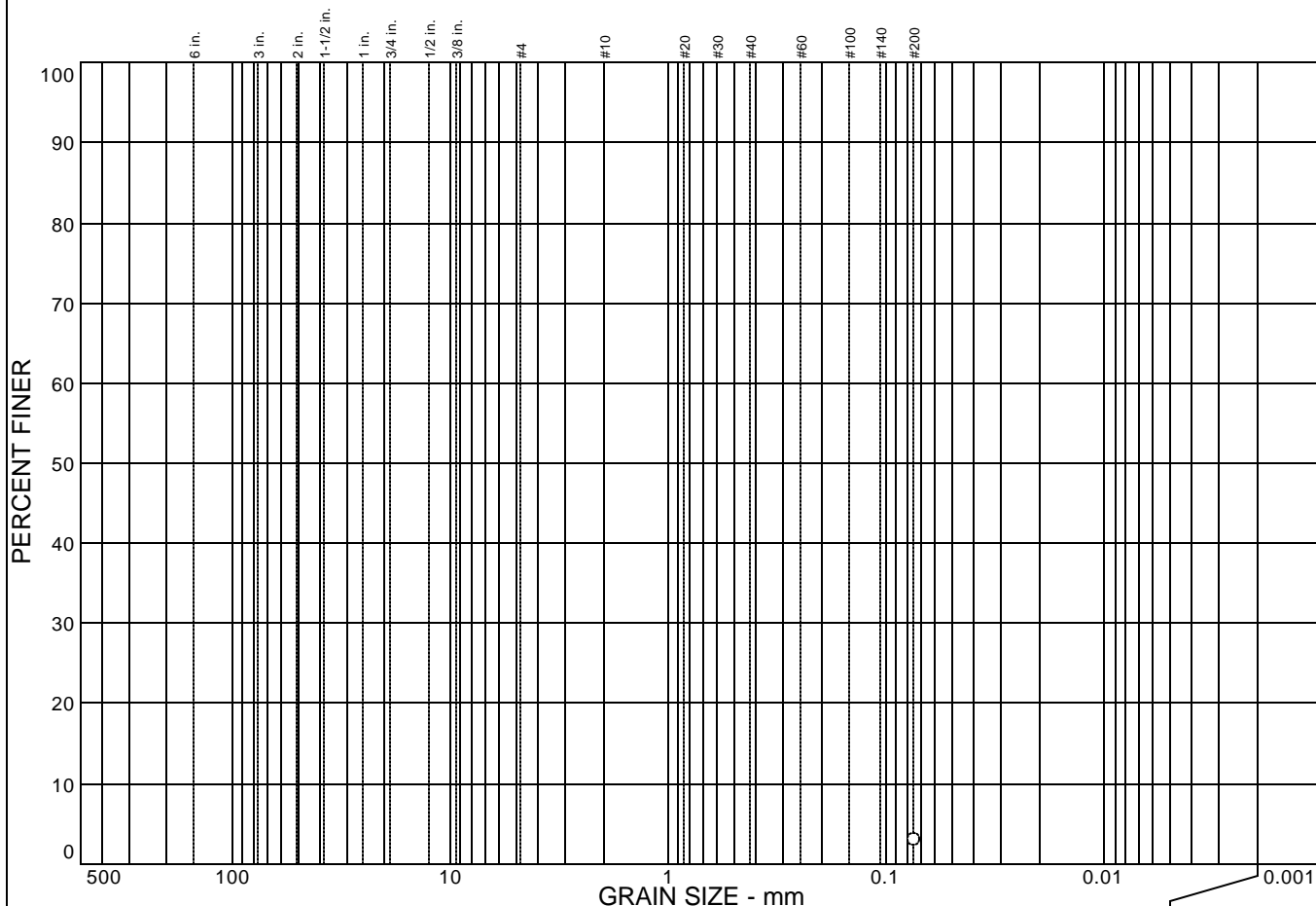

% COBBLES	% GRAVEL	% SAND	% SILT	% CLAY
			2.9	

SIEVE SIZE	PERCENT FINER	SPEC.* PERCENT	PASS? (X=NO)
#200	2.9		

Soil Description

Yellow SAND. Trace silt.

Atterberg Limits

PL= LL= PI=

Coefficients

D₈₅= D₆₀= D₅₀=
D₃₀= D₁₅= D₁₀=
C_u= C_c=

Classification

USCS= AASHTO=

Remarks

* (no specification provided)

Sample No.: B14 @ 11.0'
Location:

Source of Sample:

Date: 11/09/06
Elev./Depth: 11.0 feet



Client:
Project: Marina Coast Recycled Water Pipeline - Marina, CA

Project No.: 7496.1.001.01

Particle Size Distribution Report

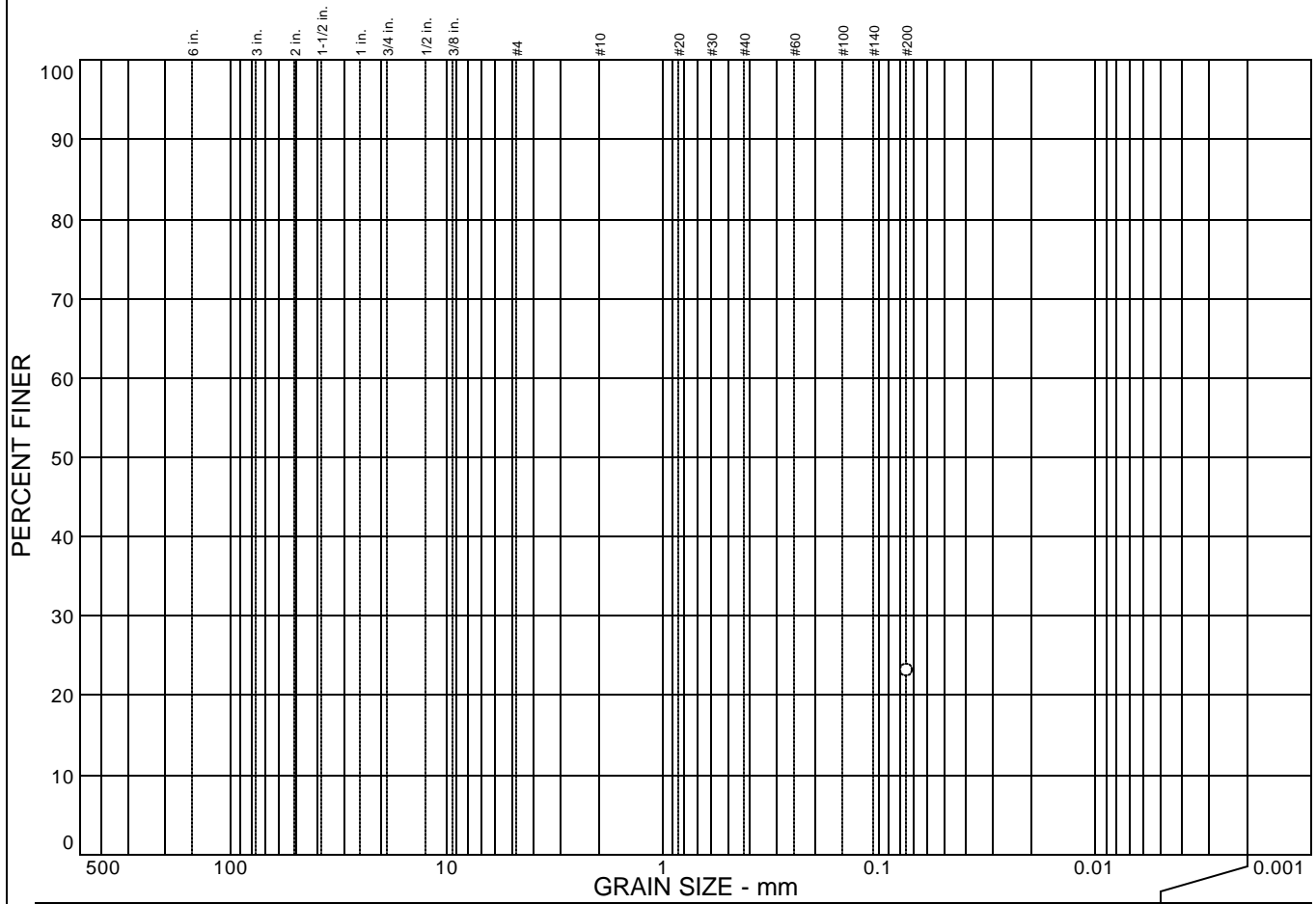

% COBBLES	% GRAVEL	% SAND	% SILT	% CLAY
			23.1	

SIEVE SIZE	PERCENT FINER	SPEC.* PERCENT	PASS? (X=NO)
#200	23.1		

Soil Description

Yellow silty SAND.

Atterberg Limits

PL= LL= PI=

Coefficients

D₈₅= D₆₀= D₅₀=
D₃₀= D₁₅= D₁₀=
C_u= C_c=

Classification

USCS= AASHTO=

Remarks

* (no specification provided)

Sample No.: B15 @ 3.0'
Location:

Source of Sample:

Date: 11/09/06
Elev./Depth: 3.0 feet



Client:
Project: Marina Coast Recycled Water Pipeline - Marina, CA

Project No.: 7496.1.001.01

Particle Size Distribution Report

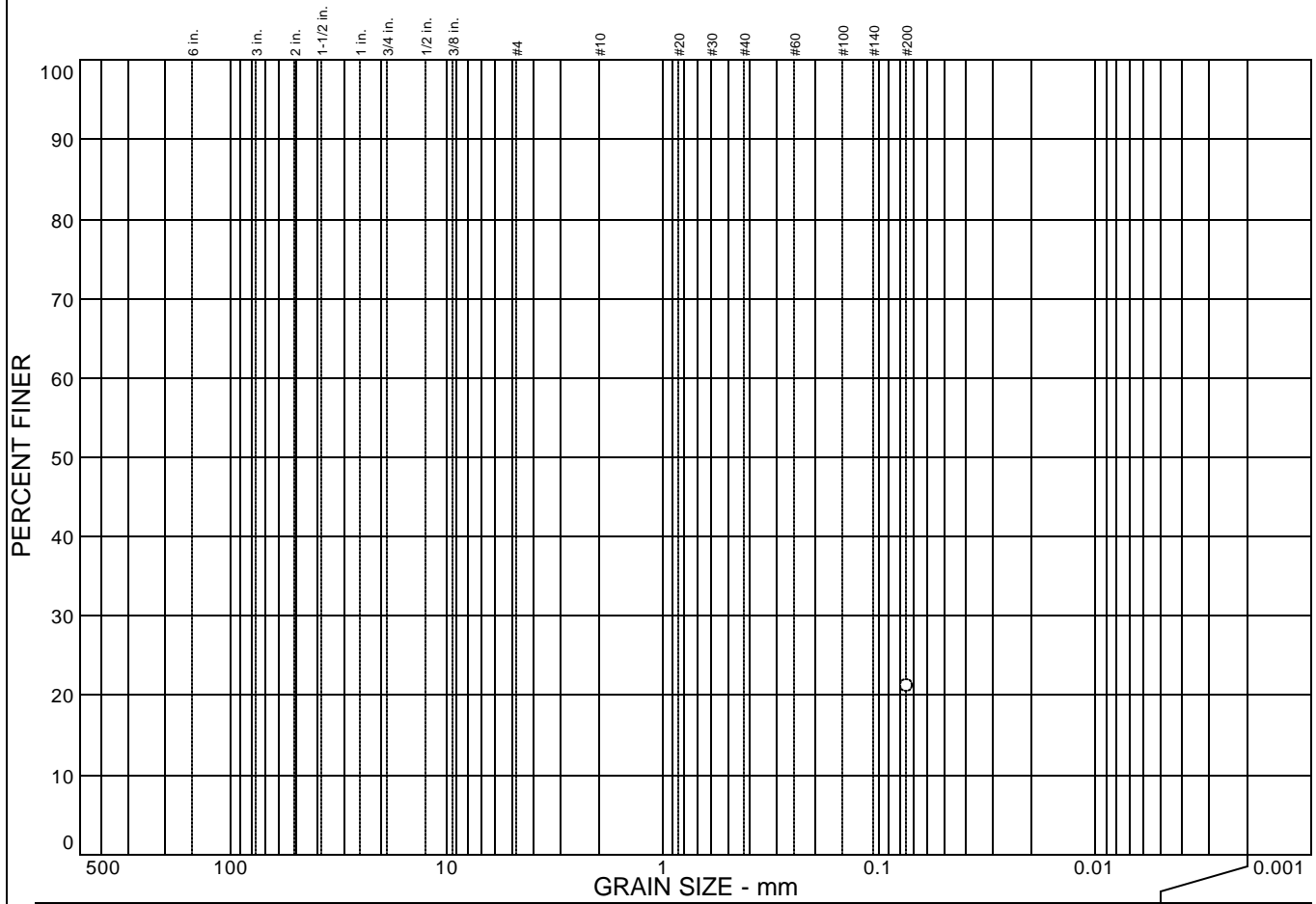

% COBBLES	% GRAVEL	% SAND	% SILT	% CLAY
			21.2	

SIEVE SIZE	PERCENT FINER	SPEC.* PERCENT	PASS? (X=NO)
#200	21.2		

Soil Description

Yellow silty SAND.

Atterberg Limits

PL= LL= PI=

Coefficients

D₈₅= D₆₀= D₅₀=
D₃₀= D₁₅= D₁₀=
C_u= C_c=

Classification

USCS= AASHTO=

Remarks

* (no specification provided)

Sample No.: B15 @ 6.0'
Location:

Source of Sample:

Date: 11/09/06
Elev./Depth: 6.0 feet



Client:
Project: Marina Coast Recycled Water Pipeline - Marina, CA

Project No.: 7496.1.001.01

Particle Size Distribution Report

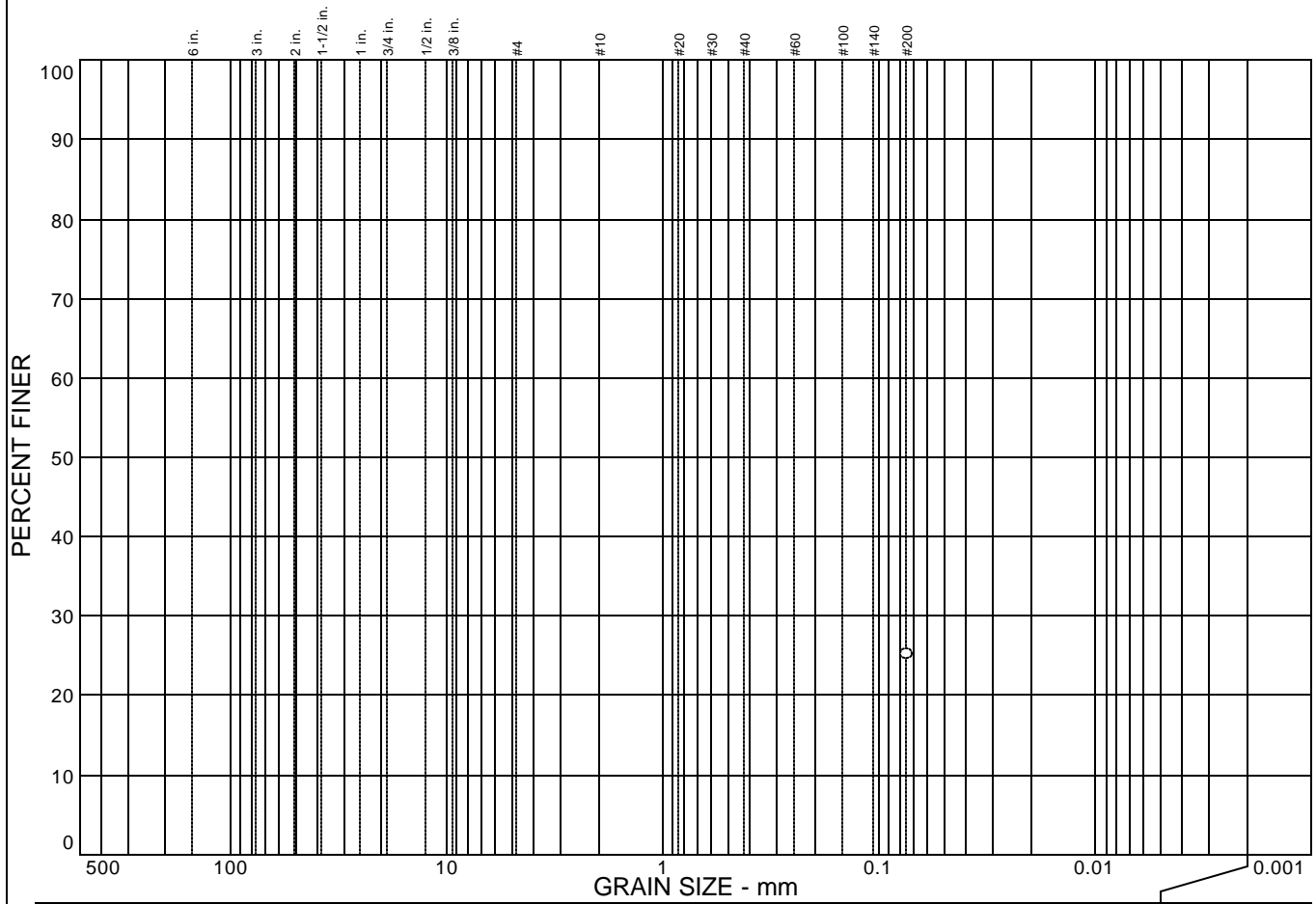

% COBBLES	% GRAVEL	% SAND	% SILT	% CLAY
			25.2	

SIEVE SIZE	PERCENT FINER	SPEC.* PERCENT	PASS? (X=NO)
#200	25.2		

Soil Description

Yellow silty SAND.

Atterberg Limits

PL= LL= PI=

Coefficients

D₈₅= D₆₀= D₅₀=
D₃₀= D₁₅= D₁₀=
C_u= C_c=

Classification

USCS= AASHTO=

Remarks

* (no specification provided)

Sample No.: B15 @ 10.5'
Location:

Source of Sample:

Date: 11/09/06
Elev./Depth: 10.5 feet



Client:
Project: Marina Coast Recycled Water Pipeline - Marina, CA

Project No.: 7496.1.001.01

Particle Size Distribution Report

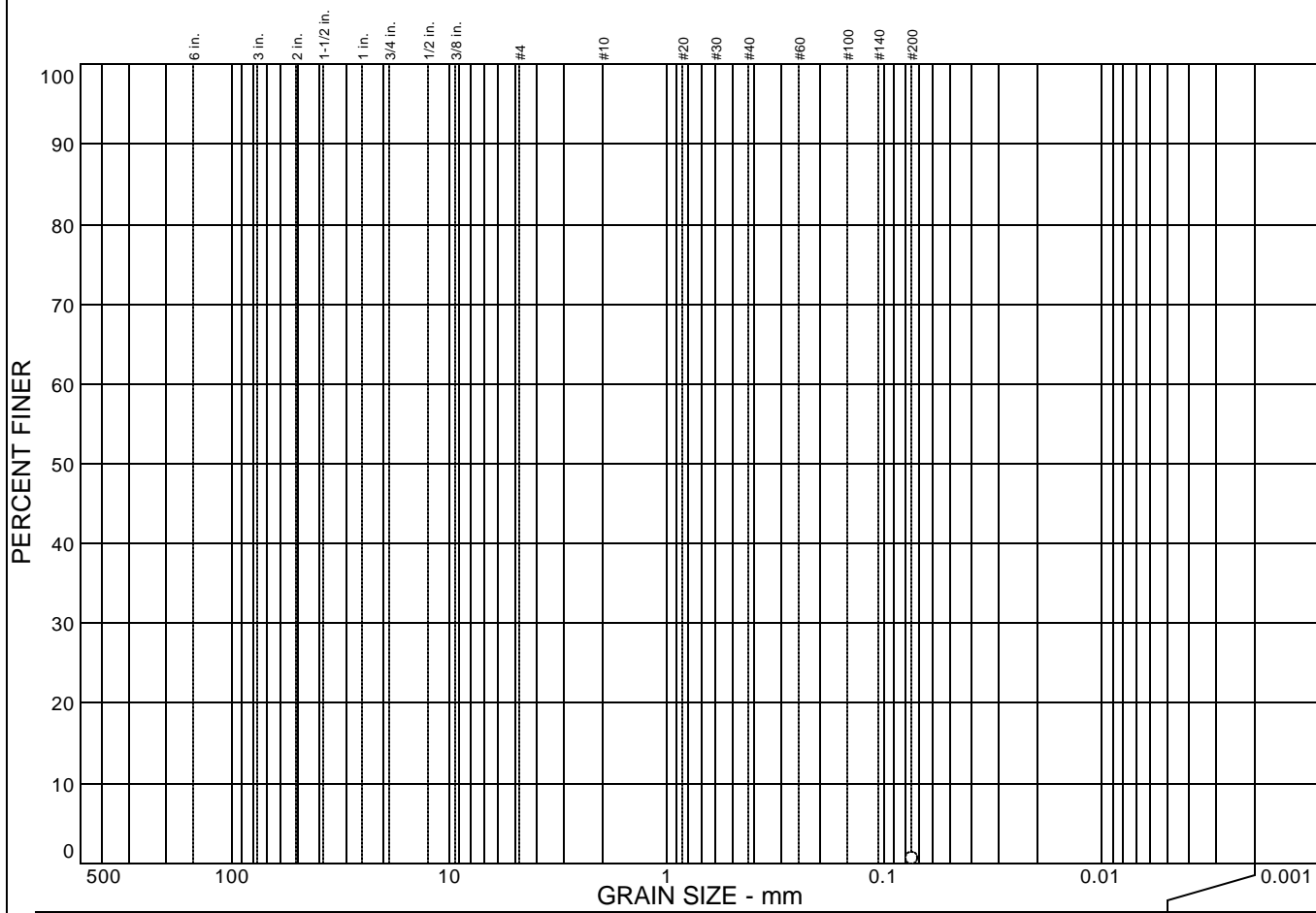

% COBBLES	% GRAVEL	% SAND	% SILT	% CLAY
			0.6	

SIEVE SIZE	PERCENT FINER	SPEC.* PERCENT	PASS? (X=NO)
#200	0.6		

Soil Description

Light yellowish brown SAND

Atterberg Limits

PL= LL= PI=

Coefficients

D₈₅= D₆₀= D₅₀=
D₃₀= D₁₅= D₁₀=
C_u= C_c=

Classification

USCS= AASHTO=

Remarks

* (no specification provided)

Sample No.: B16 @ 3.0' **Source of Sample:** **Date:** 12/04/06
Location: **Elev./Depth:** 3.0 feet

Particle Size Distribution Report



% COBBLES	% GRAVEL	% SAND	% SILT	% CLAY
0.0	0.0	98.6	0.0	1.4

SIEVE SIZE	PERCENT FINER	SPEC.* PERCENT	PASS? (X=NO)
#4	100.0		
#10	100.0		
#20	97.9		
#40	59.5		
#60	10.8		
#100	2.2		
#140	2.1		
#200	1.4		

Soil Description

Light yellowish brown poorly graded SAND

Atterberg Limits

PL= LL= PI=

Coefficients

D₈₅= 0.625 D₆₀= 0.427 D₅₀= 0.385
D₃₀= 0.316 D₁₅= 0.266 D₁₀= 0.242
C_u= 1.76 C_c= 0.96

Classification

USCS= SP AASHTO=

Remarks

* (no specification provided)

Sample No.: B16 @ 11.0'
Location:

Source of Sample:

Date: 12/01/06
Elev./Depth: 11.0 feet



Client:
Project: Marina Coast Recycled Water Pipeline - Marina, CA

Project No.: 7496.1.001.01

Particle Size Distribution Report

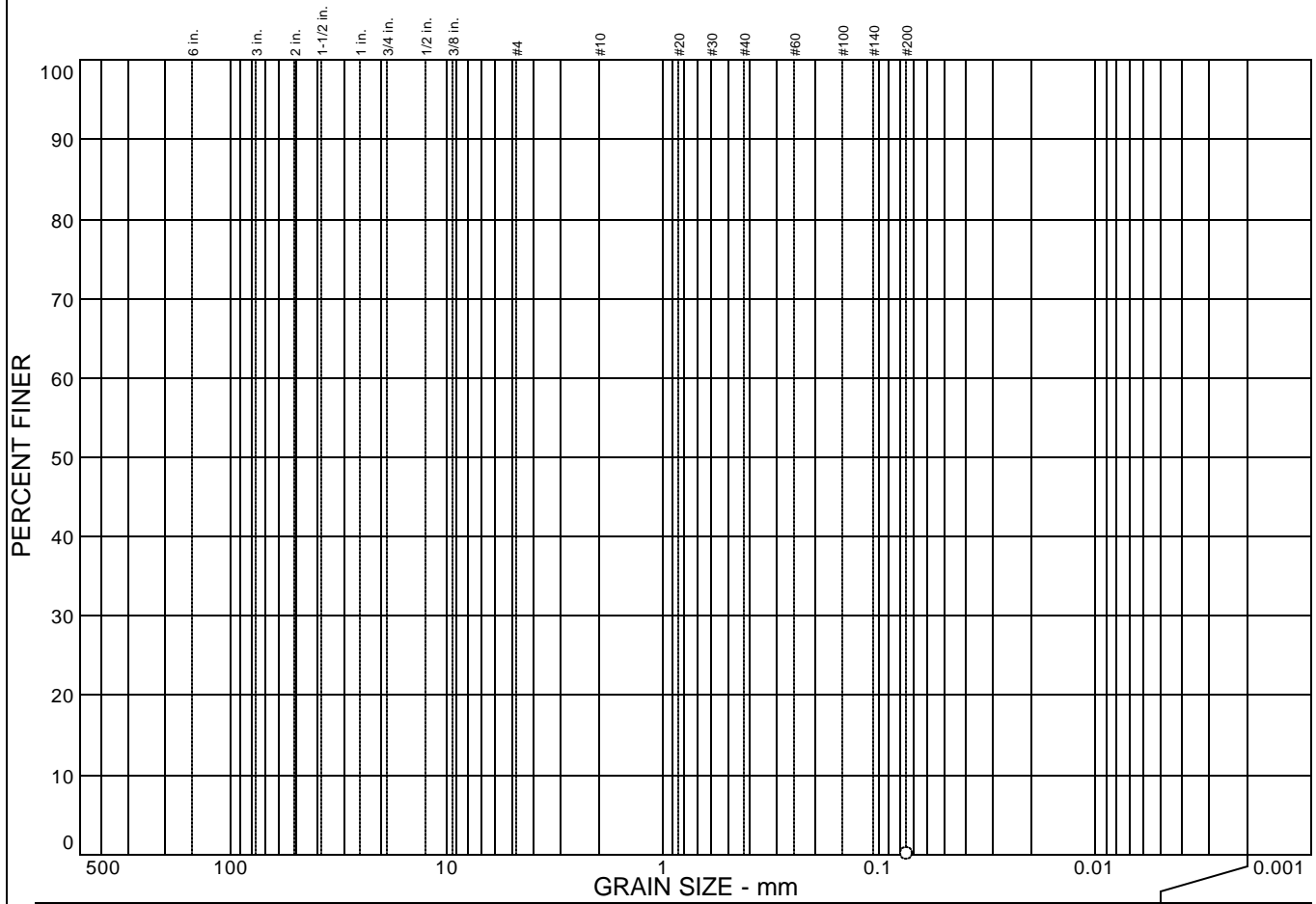

% COBBLES	% GRAVEL	% SAND	% SILT	% CLAY
			0.0	

SIEVE SIZE	PERCENT FINER	SPEC.* PERCENT	PASS? (X=NO)
#200	0.0		

Soil Description

Light yellowish brown SAND

Atterberg Limits

PL= LL= PI=

Coefficients

D₈₅= D₆₀= D₅₀=
D₃₀= D₁₅= D₁₀=
C_u= C_c=

Classification

USCS= AASHTO=

Remarks

* (no specification provided)

Sample No.: B16 @ 16.0'
Location:

Source of Sample:

Date: 12/04/06
Elev./Depth: 16.0 feet



Client:
Project: Marina Coast Recycled Water Pipeline - Marina, CA

Project No.: 7496.1.001.01

Particle Size Distribution Report

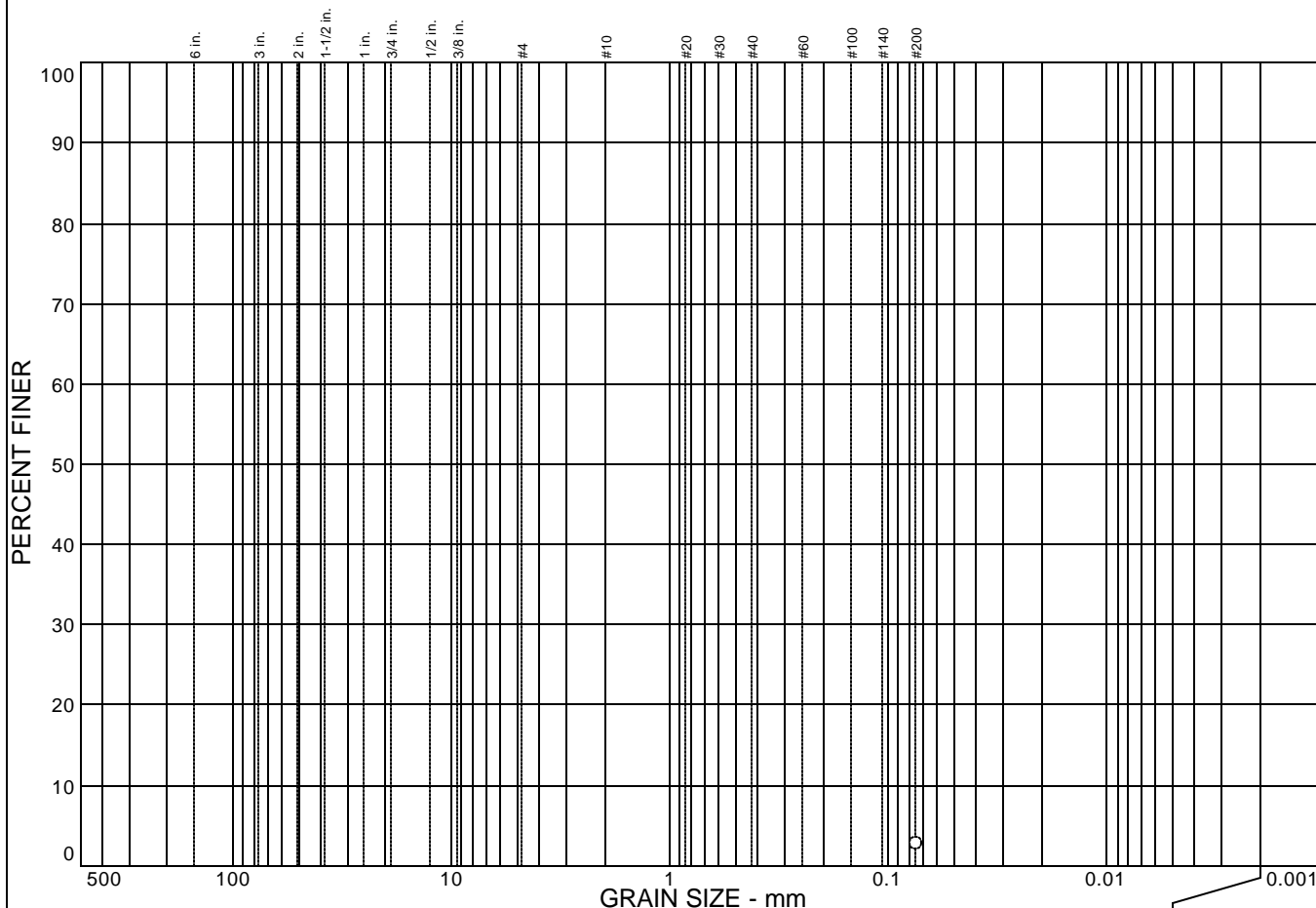

% COBBLES	% GRAVEL	% SAND	% SILT	% CLAY
			2.7	

SIEVE SIZE	PERCENT FINER	SPEC.* PERCENT	PASS? (X=NO)
#200	2.7		

Soil Description

Light yellowish brown SAND

Atterberg Limits

PL= LL= PI=

Coefficients

D₈₅= D₆₀= D₅₀=
D₃₀= D₁₅= D₁₀=
C_u= C_c=

Classification

USCS= AASHTO=

Remarks

* (no specification provided)

Sample No.: B16 @ 26.0'
Location:

Source of Sample:

Date: 12/04/06
Elev./Depth: 26.0 feet



Client:
Project: Marina Coast Recycled Water Pipeline - Marina, CA

Project No.: 7496.1.001.01

Particle Size Distribution Report

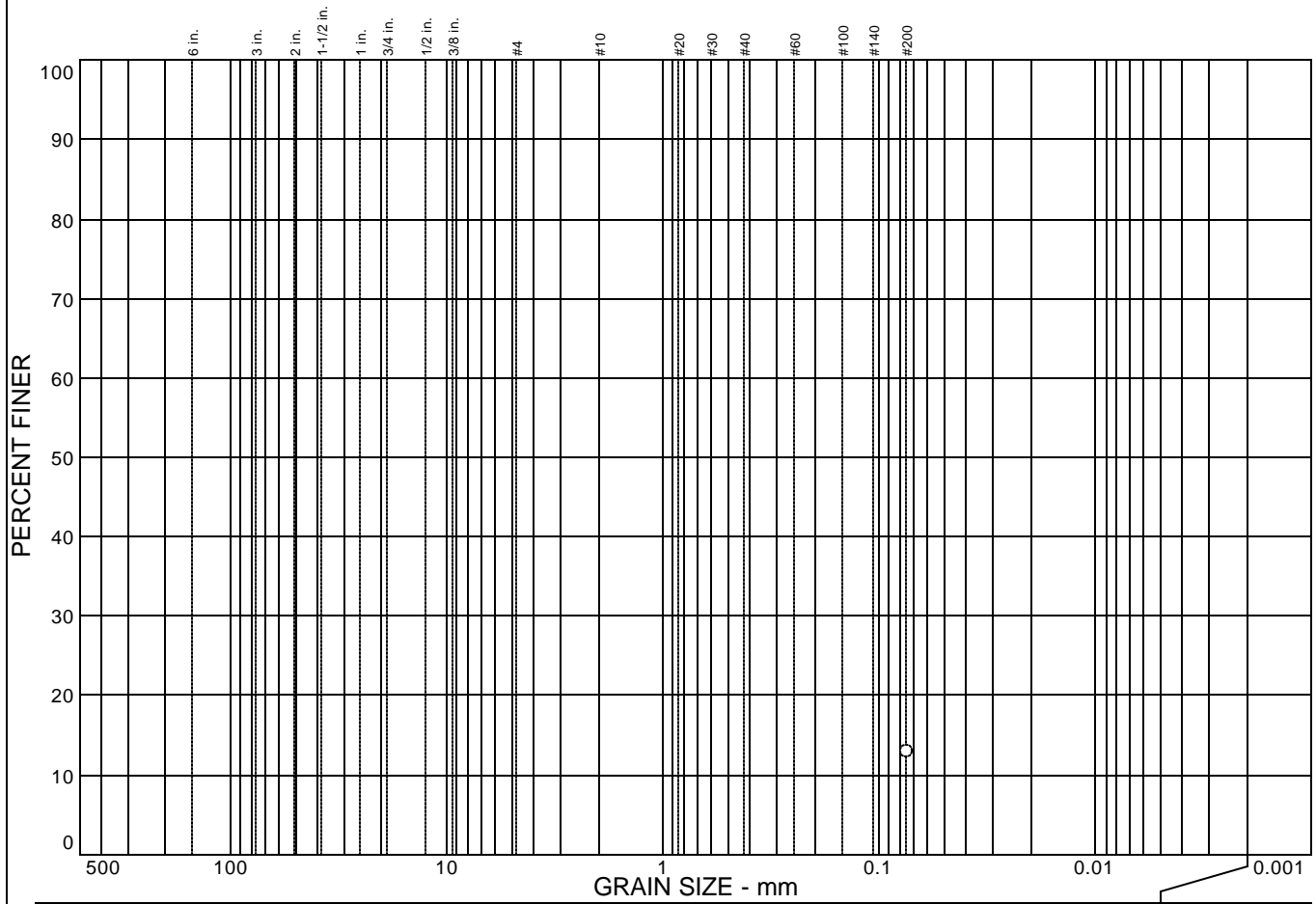

% COBBLES	% GRAVEL	% SAND	% SILT	% CLAY
			13.0	

SIEVE SIZE	PERCENT FINER	SPEC.* PERCENT	PASS? (X=NO)
#200	13.0		

Soil Description

Dark brown SAND with silt.

Atterberg Limits

PL= LL= PI=

Coefficients

D₈₅= D₆₀= D₅₀=
D₃₀= D₁₅= D₁₀=
C_u= C_c=

Classification

USCS= AASHTO=

Remarks

* (no specification provided)

Sample No.: B17 @ 3.0'
Location:

Source of Sample:

Date: 11/09/06
Elev./Depth: 3.0 feet



Client:
Project: Marina Coast Recycled Water Pipeline - Marina, CA

Project No.: 7496.1.001.01

Particle Size Distribution Report

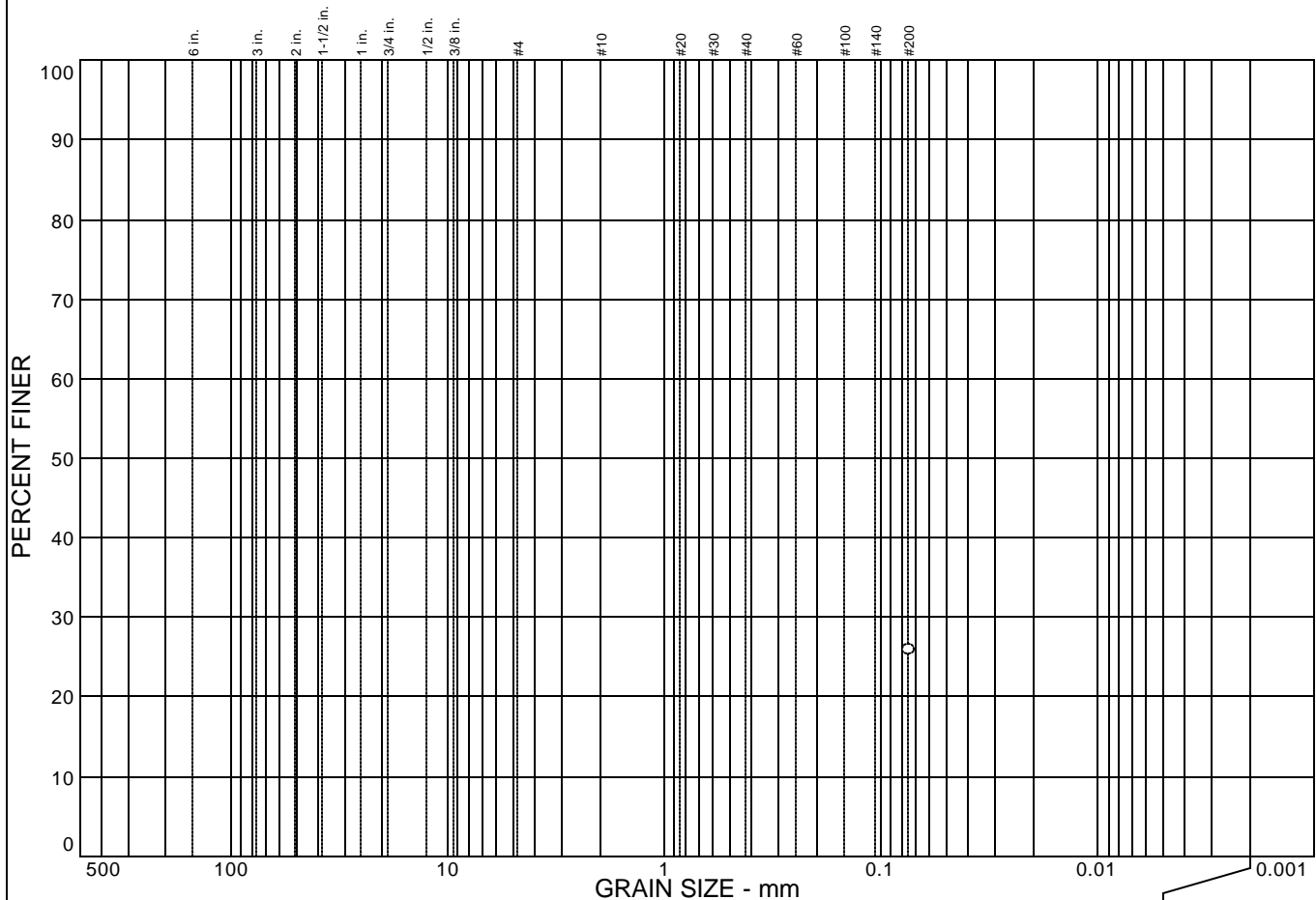

% COBBLES	% GRAVEL	% SAND	% SILT	% CLAY
			25.9	

SIEVE SIZE	PERCENT FINER	SPEC.* PERCENT	PASS? (X=NO)
#200	25.9		

Soil Description

Dark brown silty SAND.

Atterberg Limits

PL= LL= PI=

Coefficients

D₈₅= D₆₀= D₅₀=
 D₃₀= D₁₅= D₁₀=
 C_u= C_c=

Classification

USCS= AASHTO=

Remarks

* (no specification provided)

Sample No.: B17 @ 5.5'
Location:

Source of Sample:

Date: 11/09/06
Elev./Depth: 5.5 feet



Client:
Project: Marina Coast Recycled Water Pipeline - Marina, CA

Project No.: 7496.1.001.01

Particle Size Distribution Report

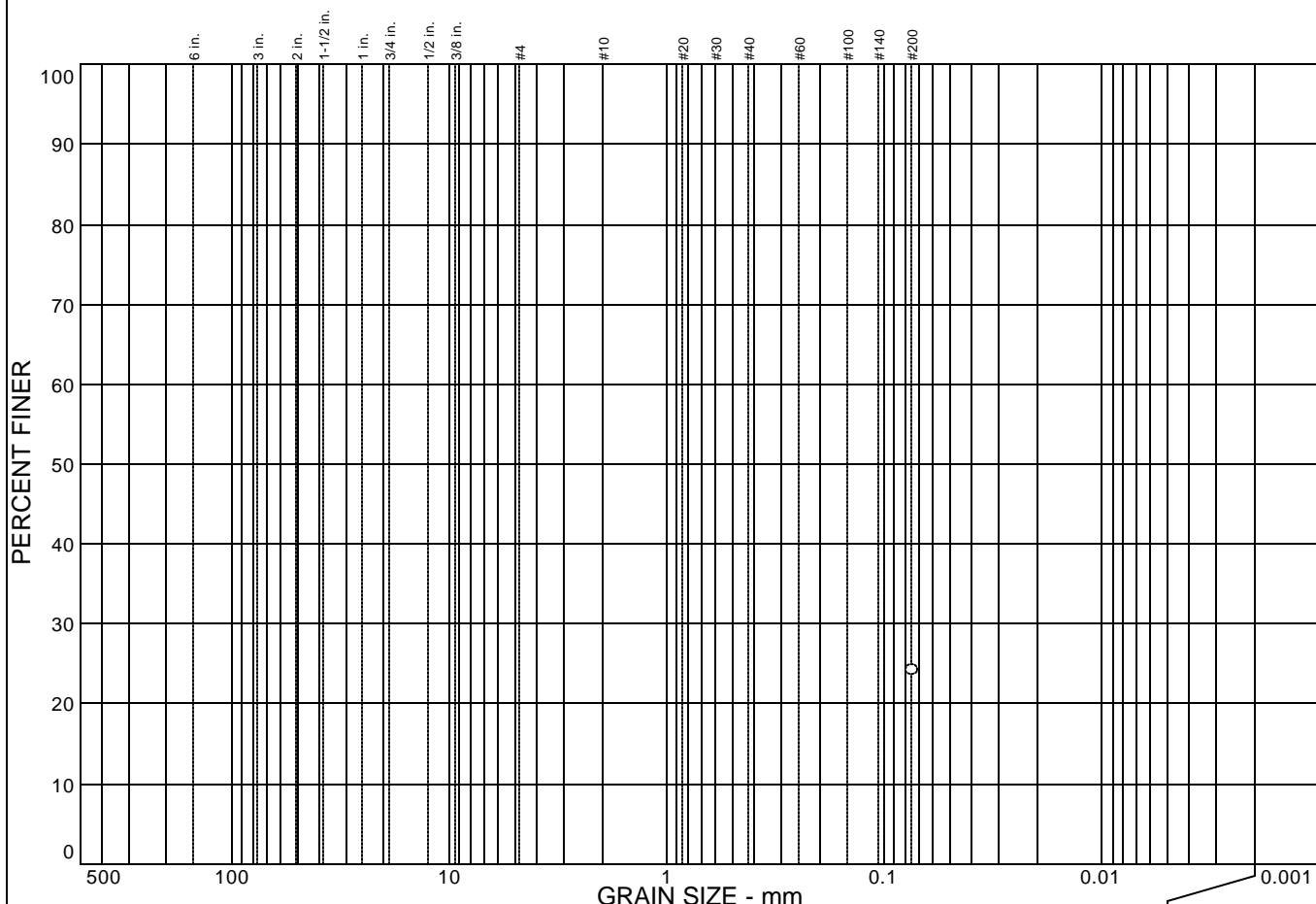

% COBBLES	% GRAVEL	% SAND	% SILT	% CLAY
			24.2	

SIEVE SIZE	PERCENT FINER	SPEC.* PERCENT	PASS? (X=NO)
#200	24.2		

Soil Description

Dark brown silty SAND.

Atterberg Limits

PL= LL= PI=

Coefficients

D₈₅= D₆₀= D₅₀=
 D₃₀= D₁₅= D₁₀=
 C_u= C_c=

Classification

USCS= AASHTO=

Remarks

* (no specification provided)

Sample No.: B17 @ 11.0'
Location:

Source of Sample:

Date: 11/09/06
Elev./Depth: 11.0 feet



Client:
Project: Marina Coast Recycled Water Pipeline - Marina, CA

Project No.: 7496.1.001.01

Particle Size Distribution Report

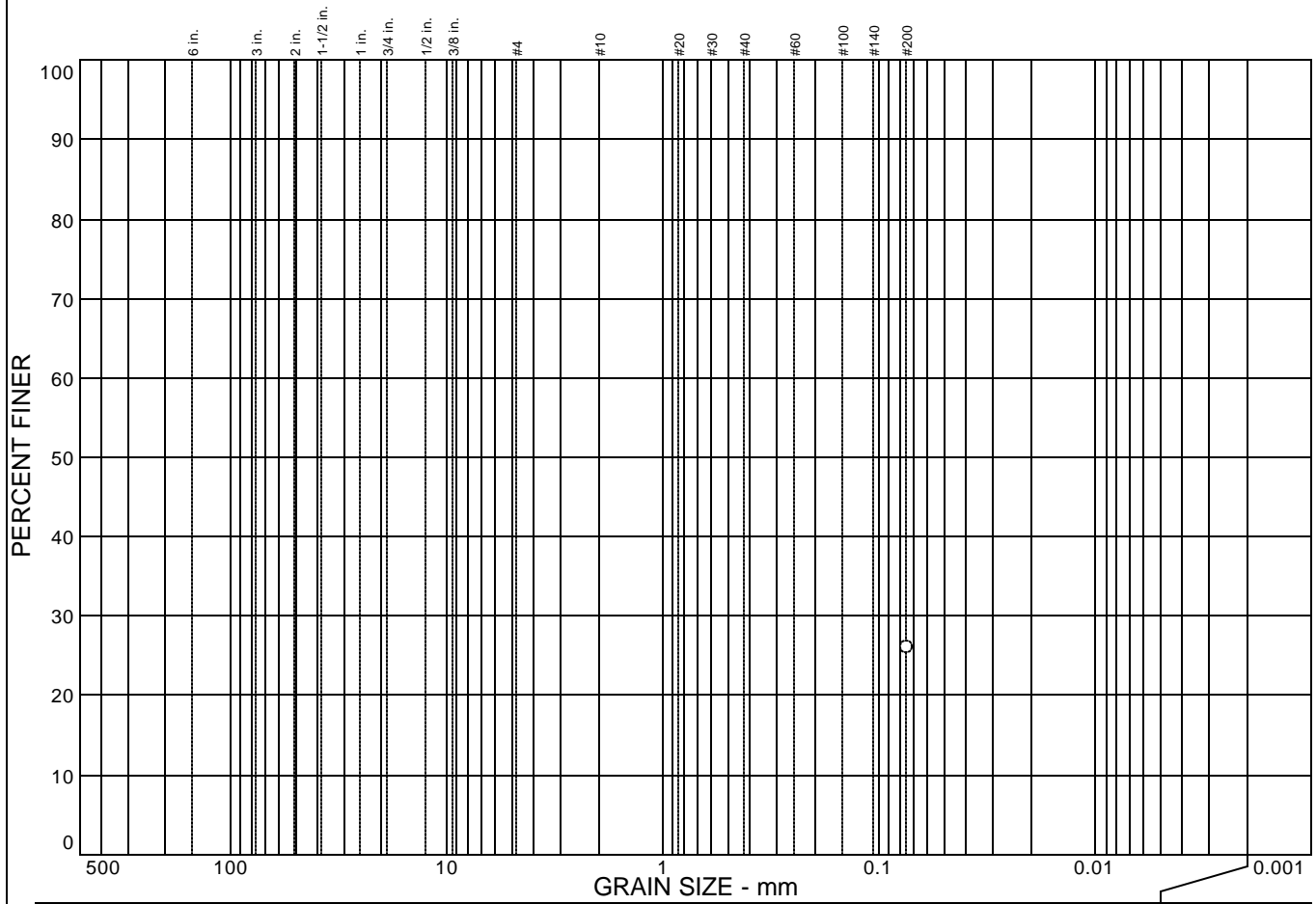

% COBBLES	% GRAVEL	% SAND	% SILT	% CLAY
			26.0	

SIEVE SIZE	PERCENT FINER	SPEC.* PERCENT	PASS? (X=NO)
#200	26.0		

Soil Description

Yellowish brown silty SAND.

Atterberg Limits

PL= LL= PI=

Coefficients

D₈₅= D₆₀= D₅₀=
D₃₀= D₁₅= D₁₀=
C_u= C_c=

Classification

USCS= AASHTO=

Remarks

* (no specification provided)

Sample No.: B18 @ 3.0'
Location:

Source of Sample:

Date: 11/09/06
Elev./Depth: 3.0 feet



Client:
Project: Marina Coast Recycled Water Pipeline - Marina, CA

Project No.: 7496.1.001.01

Particle Size Distribution Report

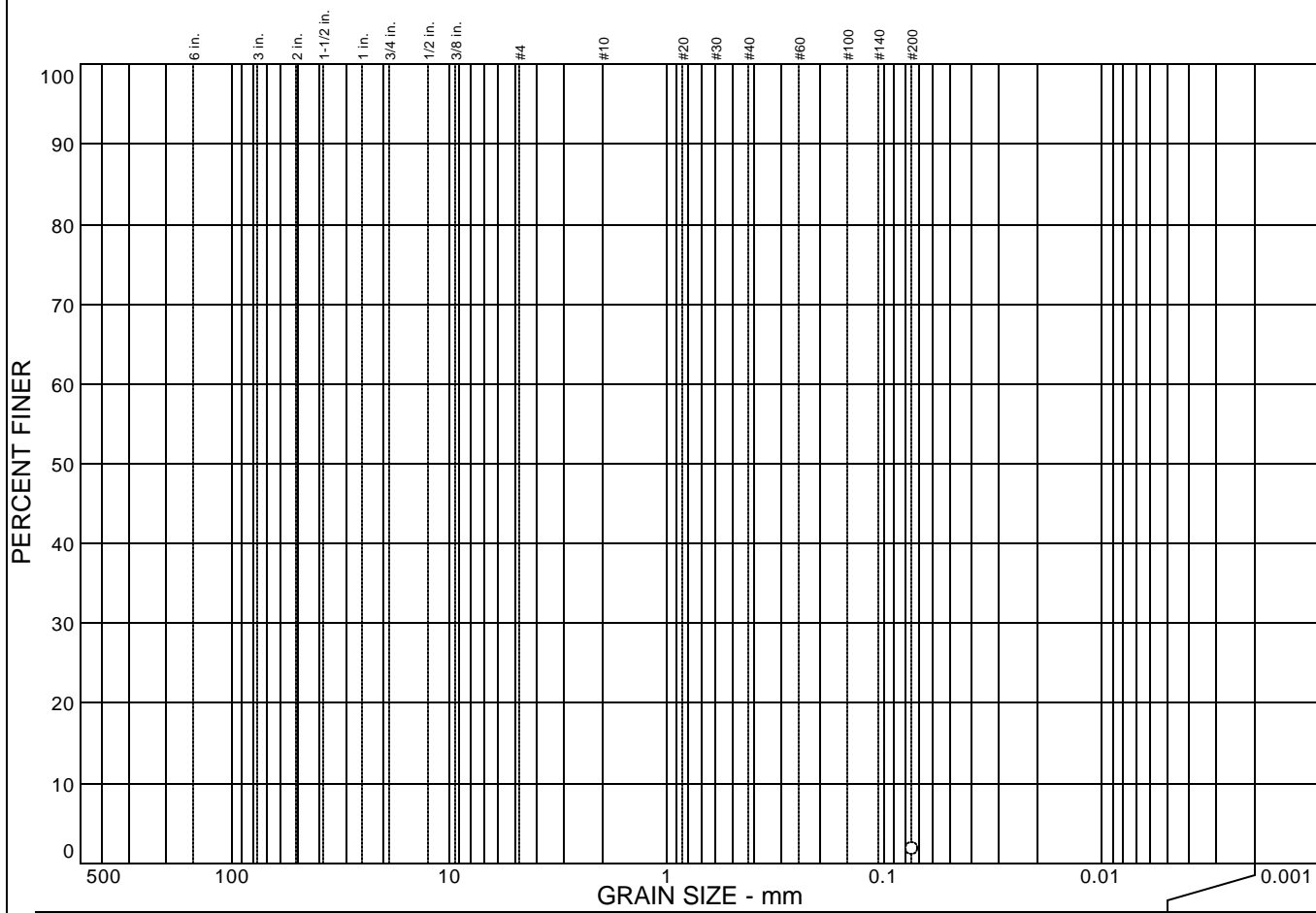

% COBBLES	% GRAVEL	% SAND	% SILT	% CLAY
			1.7	

SIEVE SIZE	PERCENT FINER	SPEC.* PERCENT	PASS? (X=NO)
#200	1.7		

Soil Description

Yellow SAND. Trace silt.

Atterberg Limits

PL= LL= PI=

Coefficients

D₈₅= D₆₀= D₅₀=
D₃₀= D₁₅= D₁₀=
C_u= C_c=

Classification

USCS= AASHTO=

Remarks

* (no specification provided)

Sample No.: B18 @ 5.5' **Source of Sample:** **Date:** 11/09/06
Location: **Elev./Depth:** 5.5 feet

Particle Size Distribution Report

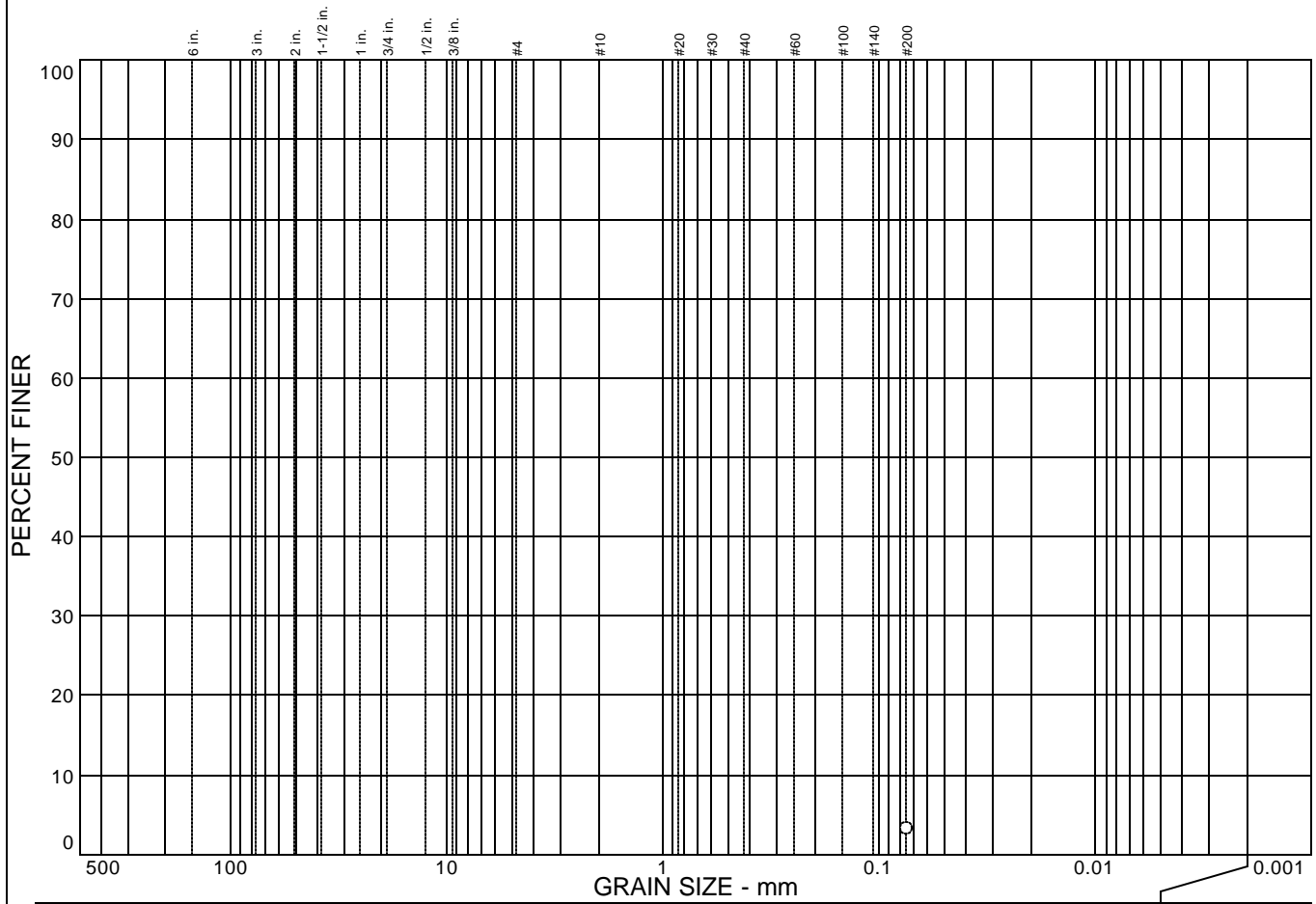

% COBBLES	% GRAVEL	% SAND	% SILT	% CLAY
			3.2	

SIEVE SIZE	PERCENT FINER	SPEC.* PERCENT	PASS? (X=NO)
#200	3.2		

Soil Description

Yellow SAND. Trace silt.

Atterberg Limits

PL= LL= PI=

Coefficients

D₈₅= D₆₀= D₅₀=
D₃₀= D₁₅= D₁₀=
C_u= C_c=

Classification

USCS= AASHTO=

Remarks

* (no specification provided)

Sample No.: B18 @ 11.0'
Location:

Source of Sample:

Date: 11/09/06
Elev./Depth: 11.0 feet



Client:
Project: Marina Coast Recycled Water Pipeline - Marina, CA

Project No.: 7496.1.001.01

Particle Size Distribution Report

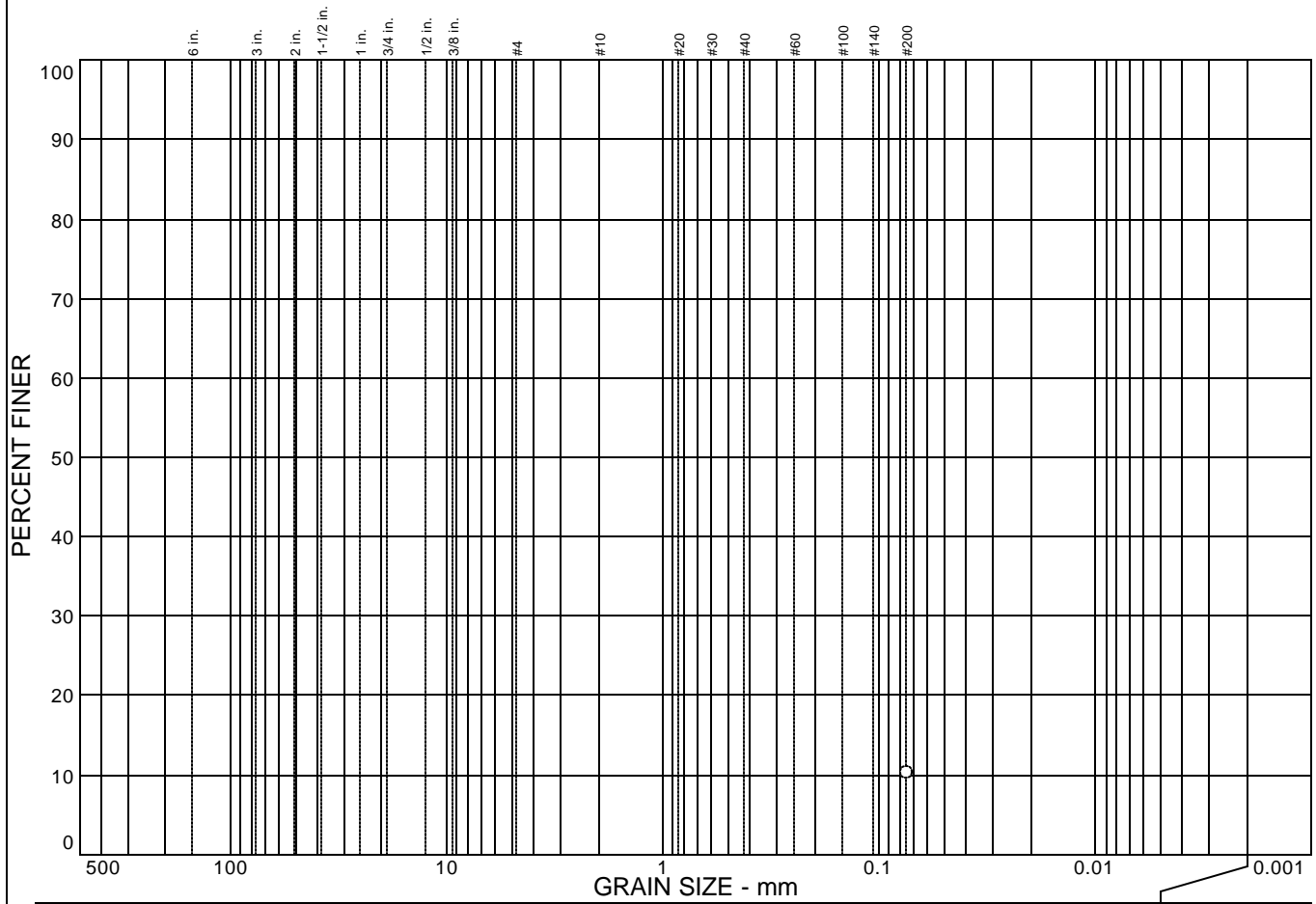

% COBBLES	% GRAVEL	% SAND	% SILT	% CLAY
			10.2	

SIEVE SIZE	PERCENT FINER	SPEC.* PERCENT	PASS? (X=NO)
#200	10.2		

Soil Description

Dark brown SAND with some silt.

Atterberg Limits

PL= LL= PI=

Coefficients

D₈₅= D₆₀= D₅₀=
D₃₀= D₁₅= D₁₀=
C_u= C_c=

Classification

USCS= AASHTO=

Remarks

* (no specification provided)

Sample No.: B19 @ 3.0'
Location:

Source of Sample:

Date: 11/09/06
Elev./Depth: 3.0 feet



Client:
Project: Marina Coast Recycled Water Pipeline - Marina, CA

Project No.: 7496.1.001.01

Particle Size Distribution Report

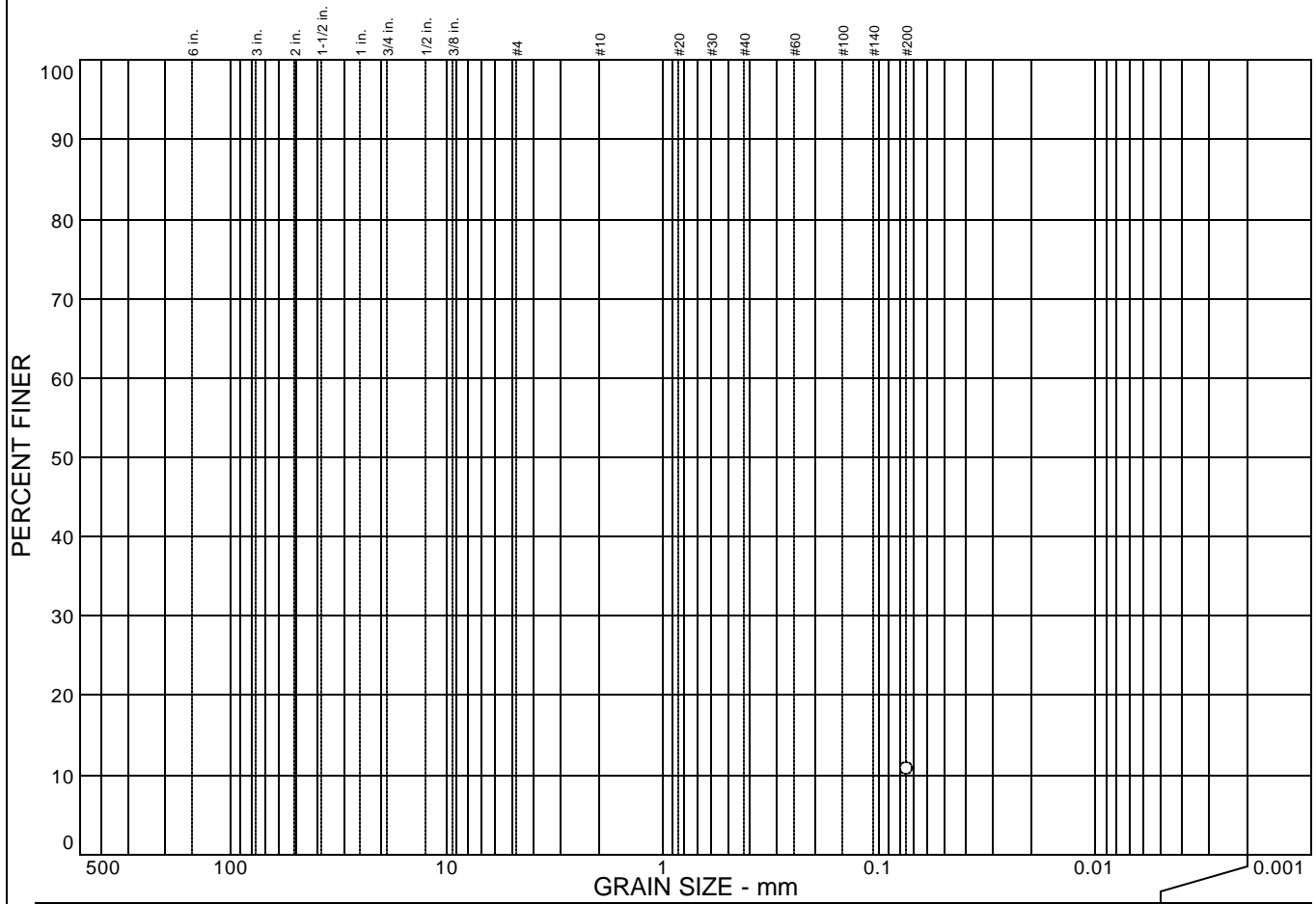

% COBBLES	% GRAVEL	% SAND	% SILT	% CLAY
			10.8	

SIEVE SIZE	PERCENT FINER	SPEC.* PERCENT	PASS? (X=NO)
#200	10.8		

Soil Description

Dark brown SAND with some silt.

Atterberg Limits

PL= LL= PI=

Coefficients

D₈₅= D₆₀= D₅₀=
D₃₀= D₁₅= D₁₀=
C_u= C_c=

Classification

USCS= AASHTO=

Remarks

* (no specification provided)

Sample No.: B19 @ 6.0'
Location:

Source of Sample:

Date: 11/09/06
Elev./Depth: 6.0 feet



Client:
Project: Marina Coast Recycled Water Pipeline - Marina, CA

Project No.: 7496.1.001.01

Particle Size Distribution Report

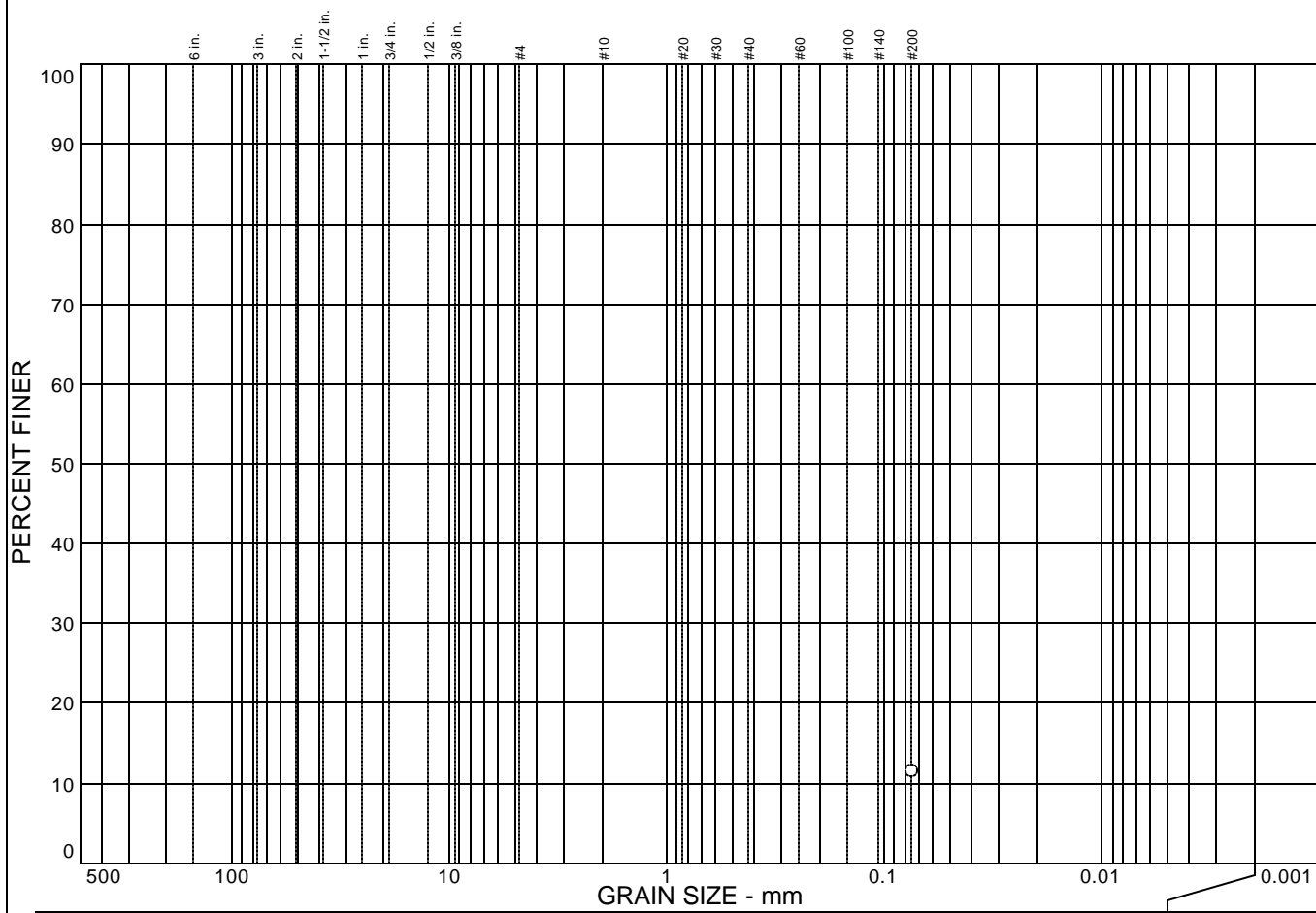

% COBBLES	% GRAVEL	% SAND	% SILT	% CLAY
			11.5	

SIEVE SIZE	PERCENT FINER	SPEC.* PERCENT	PASS? (X=NO)
#200	11.5		

Soil Description

Yellowish brown SAND with some silt.

Atterberg Limits

PL= LL= PI=

Coefficients

D₈₅= D₆₀= D₅₀=
D₃₀= D₁₅= D₁₀=
C_u= C_c=

Classification

USCS= AASHTO=

Remarks

* (no specification provided)

Sample No.: B19 @ 11.0' **Source of Sample:** **Date:** 11/09/06
Location: **Elev./Depth:** 11.0 feet

Particle Size Distribution Report

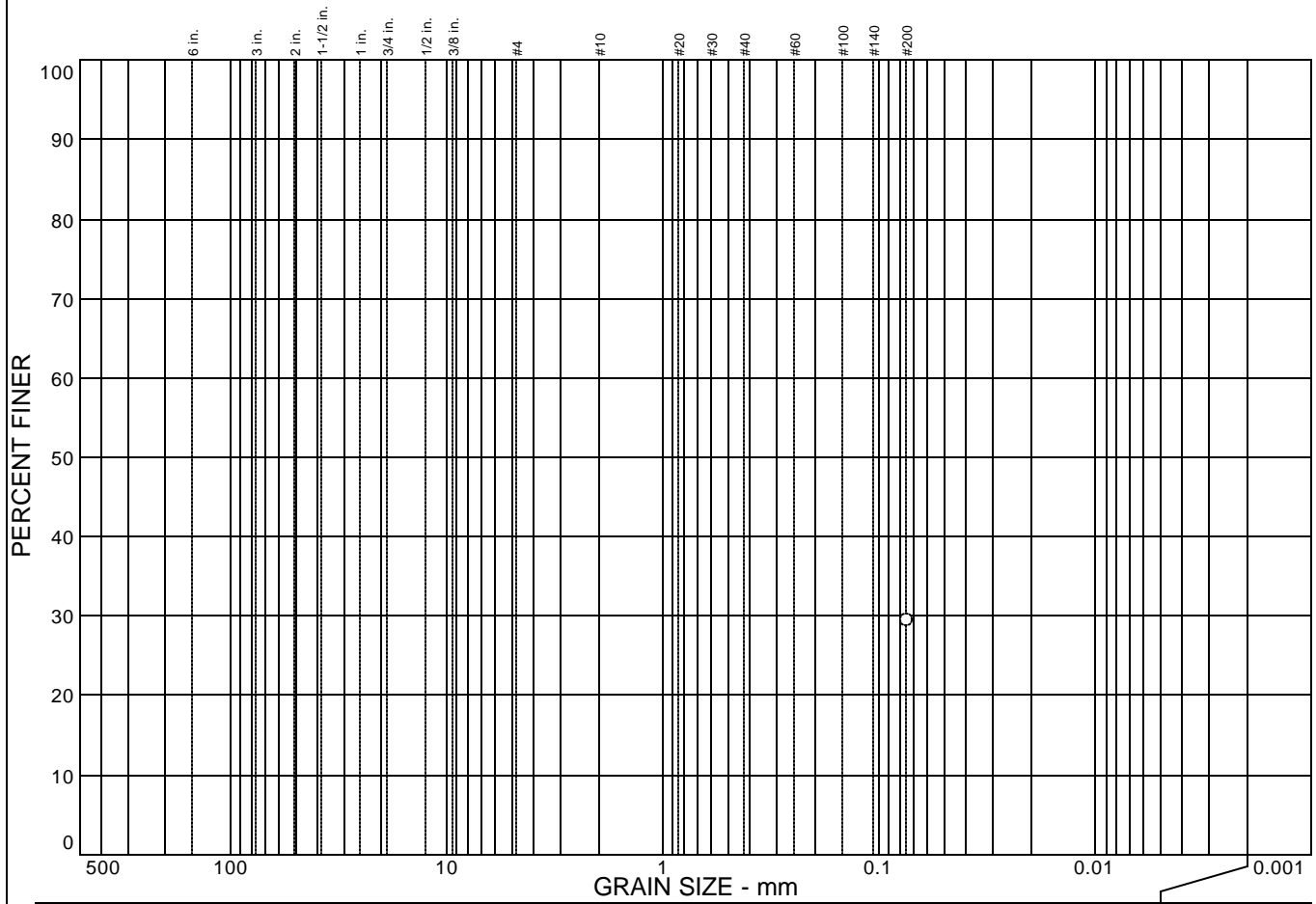

% COBBLES	% GRAVEL	% SAND	% SILT	% CLAY
			29.5	

SIEVE SIZE	PERCENT FINER	SPEC.* PERCENT	PASS? (X=NO)
#200	29.5		

Soil Description

Yellowish brown silty SAND.

Atterberg Limits

PL= LL= PI=

Coefficients

D₈₅= D₆₀= D₅₀=
D₃₀= D₁₅= D₁₀=
C_u= C_c=

Classification

USCS= AASHTO=

Remarks

* (no specification provided)

Sample No.: B20 @ 3.0'
Location:

Source of Sample:

Date: 11/09/06
Elev./Depth: 3.0 feet



Client:
Project: Marina Coast Recycled Water Pipeline - Marina, CA

Project No.: 7496.1.001.01

Particle Size Distribution Report

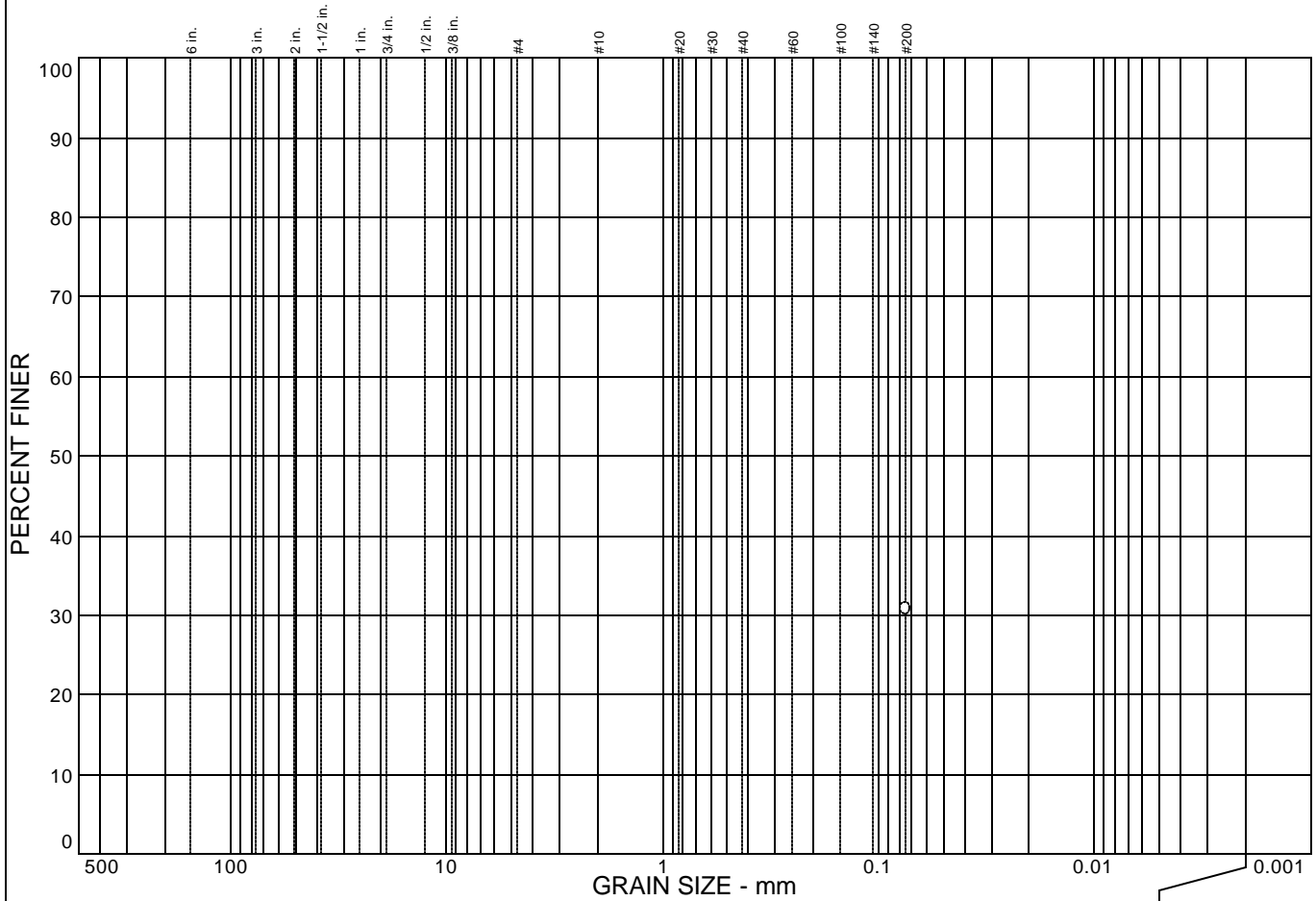

% COBBLES	% GRAVEL	% SAND	% SILT	% CLAY
			30.9	

SIEVE SIZE	PERCENT FINER	SPEC.* PERCENT	PASS? (X=NO)
#200	30.9		

Soil Description

Yellowish brown silty SAND.

Atterberg Limits

PL= LL= PI=

Coefficients

D₈₅= D₆₀= D₅₀=
D₃₀= D₁₅= D₁₀=
C_u= C_c=

Classification

USCS= AASHTO=

Remarks

* (no specification provided)

Sample No.: B20 @ 6.0' **Source of Sample:** **Date:** 11/10/06
Location: **Elev./Depth:** 6.0 feet

Particle Size Distribution Report

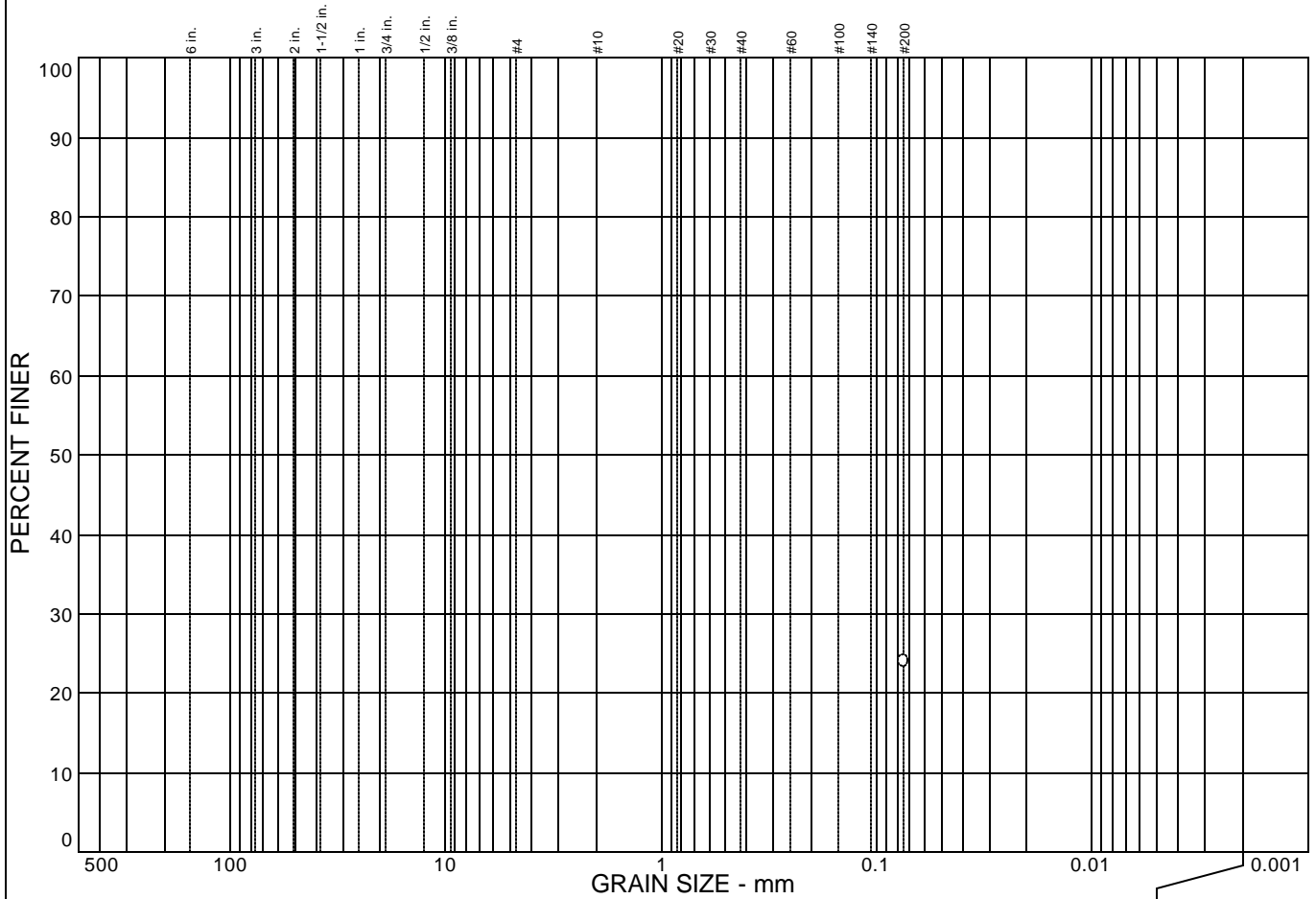

% COBBLES	% GRAVEL	% SAND	% SILT	% CLAY
			24.1	

SIEVE SIZE	PERCENT FINER	SPEC.* PERCENT	PASS? (X=NO)
#200	24.1		

Soil Description
Yellowish brown SAND with some silt.

Atterberg Limits
 PL= LL= PI=

Coefficients
 D₈₅= D₆₀= D₅₀=
 D₃₀= D₁₅= D₁₀=
 C_u= C_c=

Classification
 USCS= AASHTO=

Remarks

* (no specification provided)

Sample No.: B20 @ 11.0' **Source of Sample:** **Date:** 11/10/06
Location: **Elev./Depth:** 11.0 feet

Particle Size Distribution Report

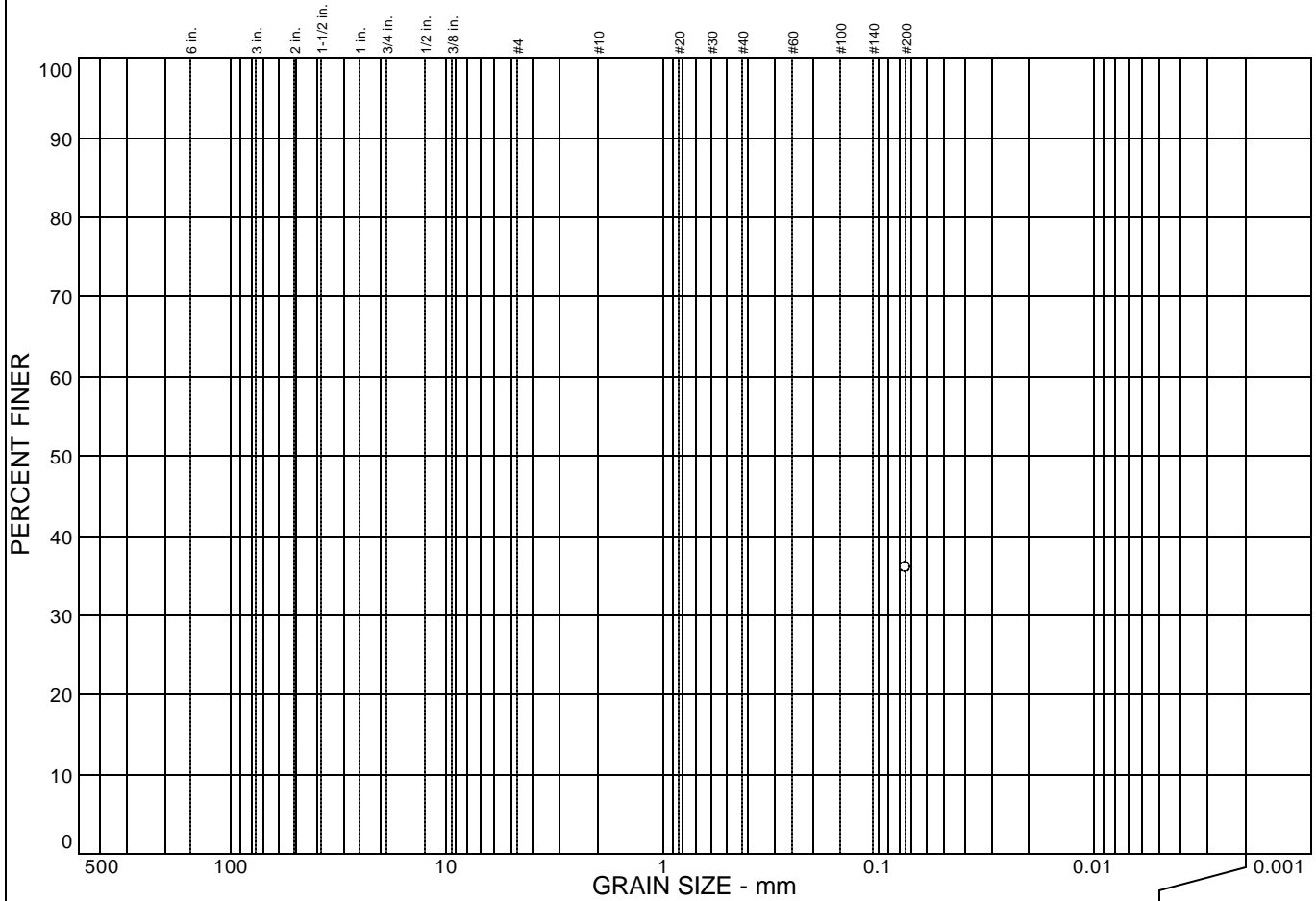

% COBBLES	% GRAVEL	% SAND	% SILT	% CLAY
			36.0	

SIEVE SIZE	PERCENT FINER	SPEC.* PERCENT	PASS? (X=NO)
#200	36.0		

Soil Description

Yellowish brown silty SAND.

Atterberg Limits

PL= LL= PI=

Coefficients

D₈₅= D₆₀= D₅₀=
D₃₀= D₁₅= D₁₀=
C_u= C_c=

Classification

USCS= AASHTO=

Remarks

* (no specification provided)

Sample No.: B21 @ 3.0' **Source of Sample:** **Date:** 11/10/06
Location: **Elev./Depth:** 3.0 feet

Particle Size Distribution Report

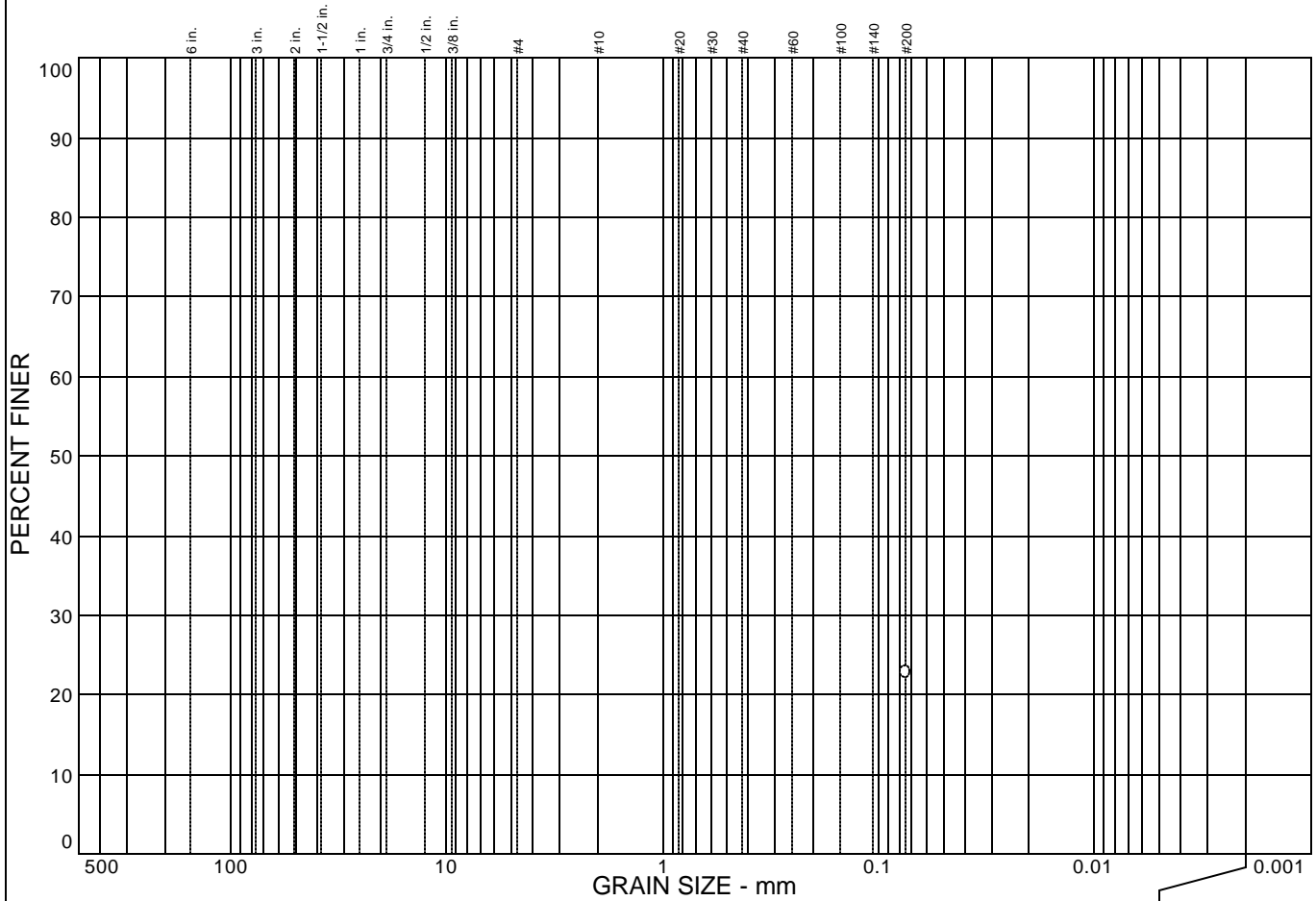

% COBBLES	% GRAVEL	% SAND	% SILT	% CLAY
			22.9	

SIEVE SIZE	PERCENT FINER	SPEC.* PERCENT	PASS? (X=NO)
#200	22.9		

Soil Description
Yellowish brown SAND with some silt.

Atterberg Limits
 PL= LL= PI=

Coefficients
 D₈₅= D₆₀= D₅₀=
 D₃₀= D₁₅= D₁₀=
 C_u= C_c=

Classification
 USCS= AASHTO=

Remarks

* (no specification provided)

Sample No.: B21 @ 6.0' **Source of Sample:** **Date:** 11/10/06
Location: **Elev./Depth:** 6.0 feet

Particle Size Distribution Report

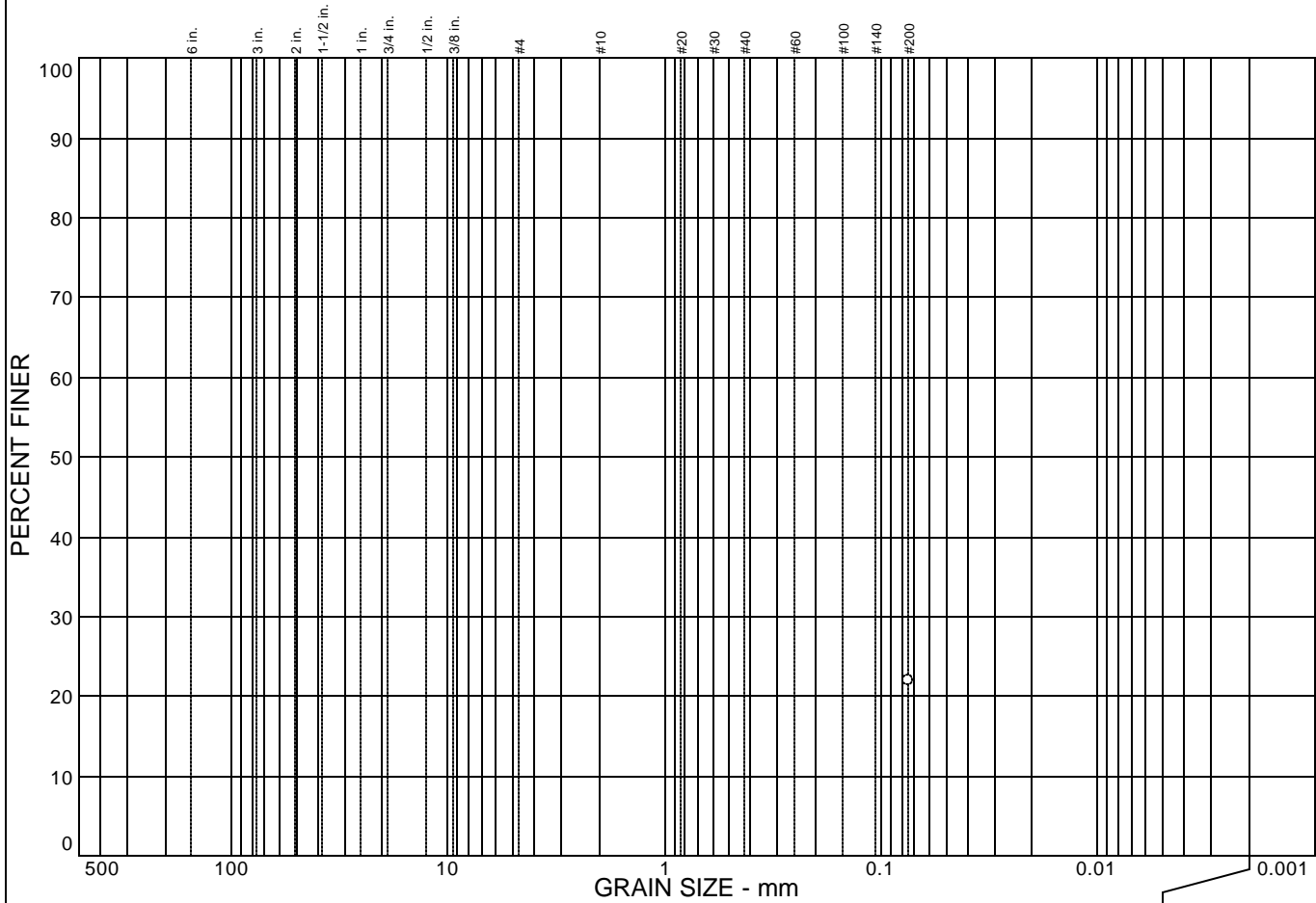

% COBBLES	% GRAVEL	% SAND	% SILT	% CLAY
			22.0	

SIEVE SIZE	PERCENT FINER	SPEC.* PERCENT	PASS? (X=NO)
#200	22.0		

Soil Description
Yellowish brown SAND with some silt.

Atterberg Limits
 PL= LL= PI=

Coefficients
 D₈₅= D₆₀= D₅₀=
 D₃₀= D₁₅= D₁₀=
 C_u= C_c=

Classification
 USCS= AASHTO=

Remarks

* (no specification provided)

Sample No.: B21 @ 11.0' **Source of Sample:** **Date:** 11/10/09
Location: **Elev./Depth:** 11.0 feet

Particle Size Distribution Report

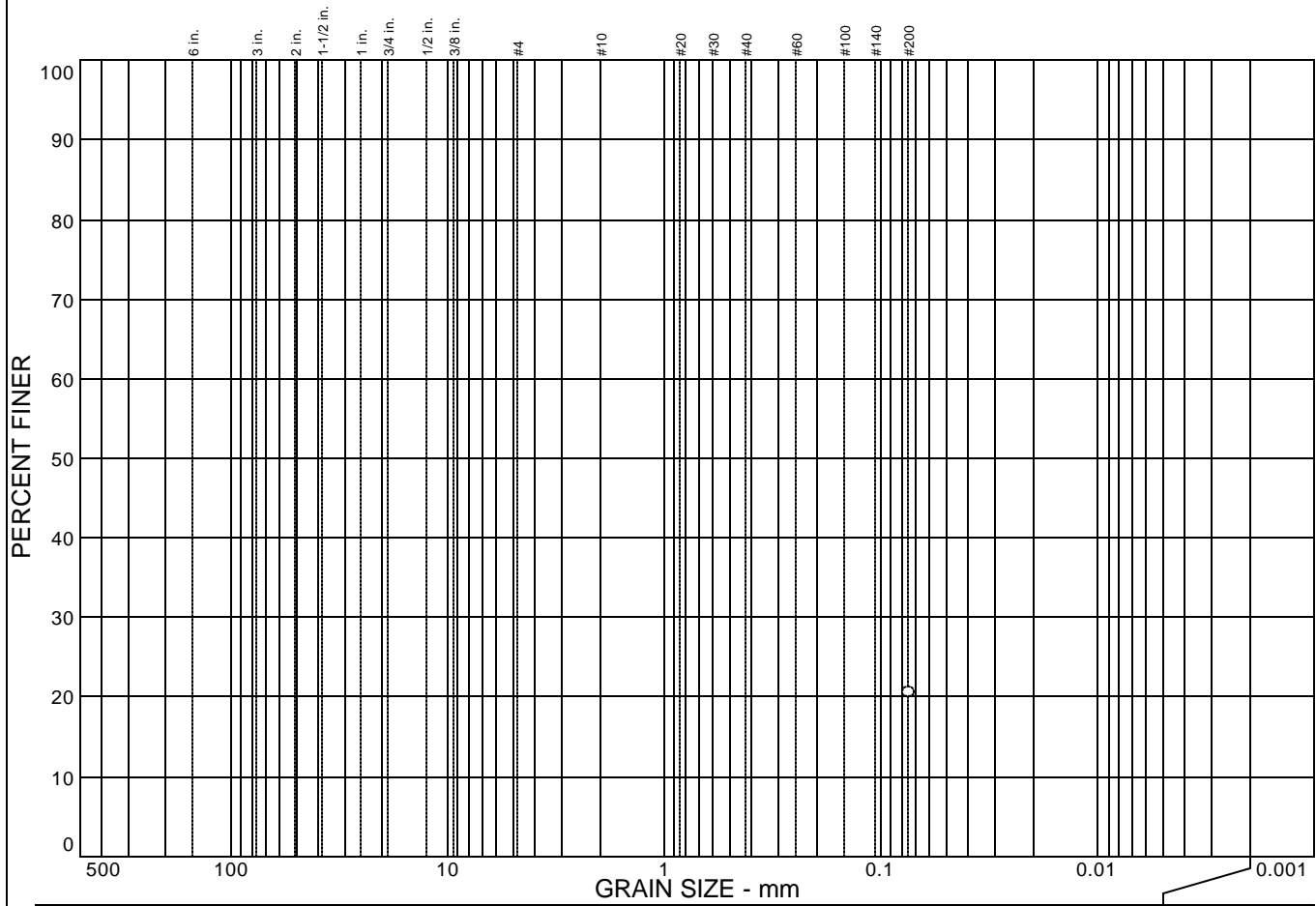

% COBBLES	% GRAVEL	% SAND	% SILT	% CLAY
			20.6	

SIEVE SIZE	PERCENT FINER	SPEC.* PERCENT	PASS? (X=NO)
#200	20.6		

Soil Description

Dark yellowish brown SAND with silt

Atterberg Limits

PL= LL= PI=

Coefficients

D₈₅= D₆₀= D₅₀=
D₃₀= D₁₅= D₁₀=
C_u= C_c=

Classification

USCS= AASHTO=

Remarks

* (no specification provided)

Sample No.: B22 @ 3.0'
Location:

Source of Sample:

Date: 12/04/06
Elev./Depth: 3.0 feet



Client:
Project: Marina Coast Recycled Water Pipeline - Marina, CA

Project No.: 7496.1.001.01

Particle Size Distribution Report

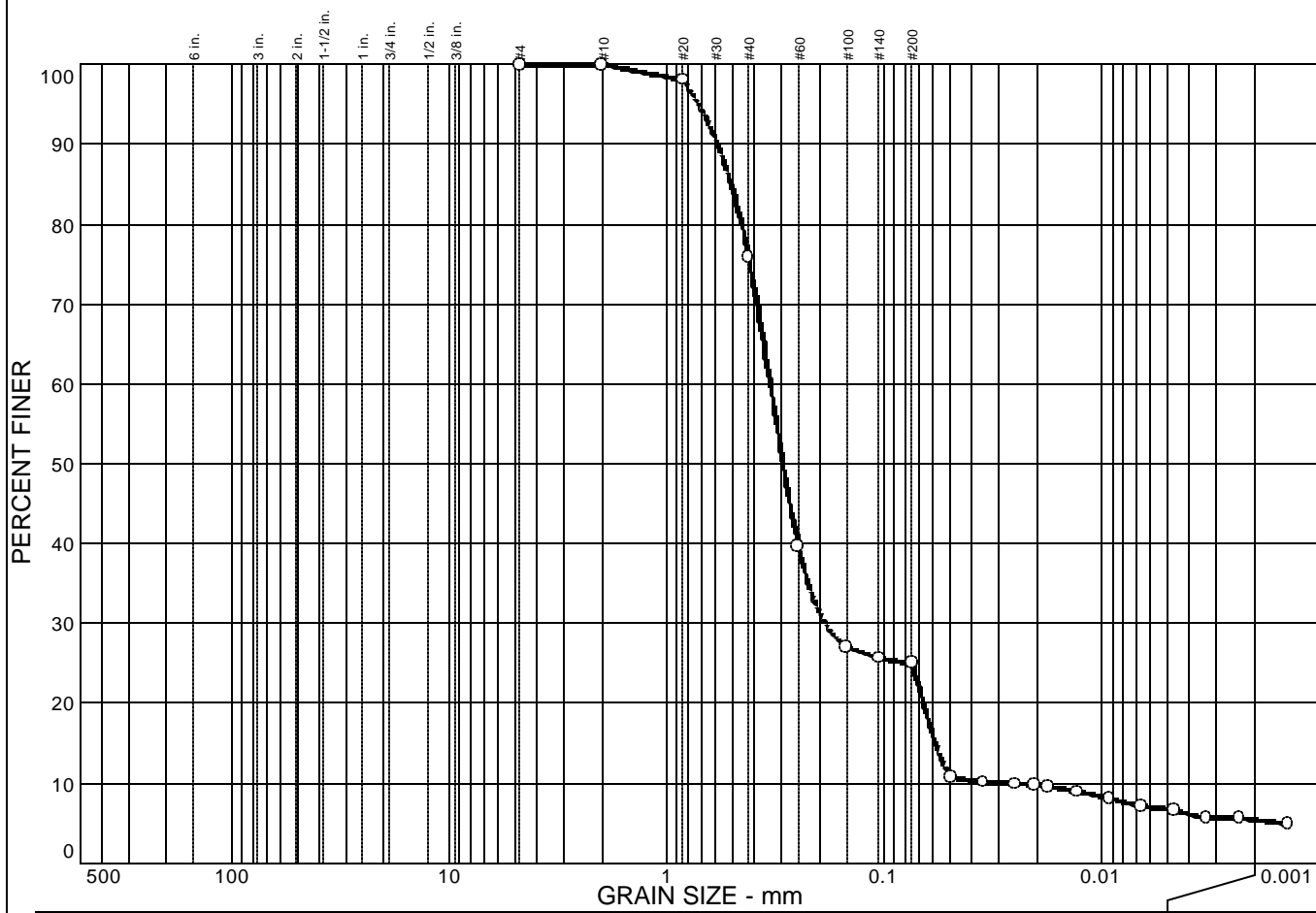

% COBBLES	% GRAVEL	% SAND	% SILT	% CLAY
0.0	0.0	75.0	19.6	5.4

SIEVE SIZE	PERCENT FINER	SPEC.* PERCENT	PASS? (X=NO)
#4	100.0		
#10	100.0		
#20	98.1		
#40	75.8		
#60	39.6		
#100	27.1		
#140	25.7		
#200	25.0		

Soil Description

Yellowish brown silty SAND.

Atterberg Limits

PL= LL= PI=

Coefficients

D₈₅= 0.511 D₆₀= 0.339 D₅₀= 0.295
D₃₀= 0.188 D₁₅= 0.0587 D₁₀= 0.0316
C_u= 10.73 C_c= 3.30

Classification

USCS= SM AASHTO=

Remarks

* (no specification provided)

Sample No.: B22 @ 6.0'
Location:

Source of Sample:

Date: 12/01/06
Elev./Depth: 6.0 feet



Client:
Project: Marina Coast Recycled Water Pipeline - Marina, CA

Project No.: 7496.1.001.01

Particle Size Distribution Report

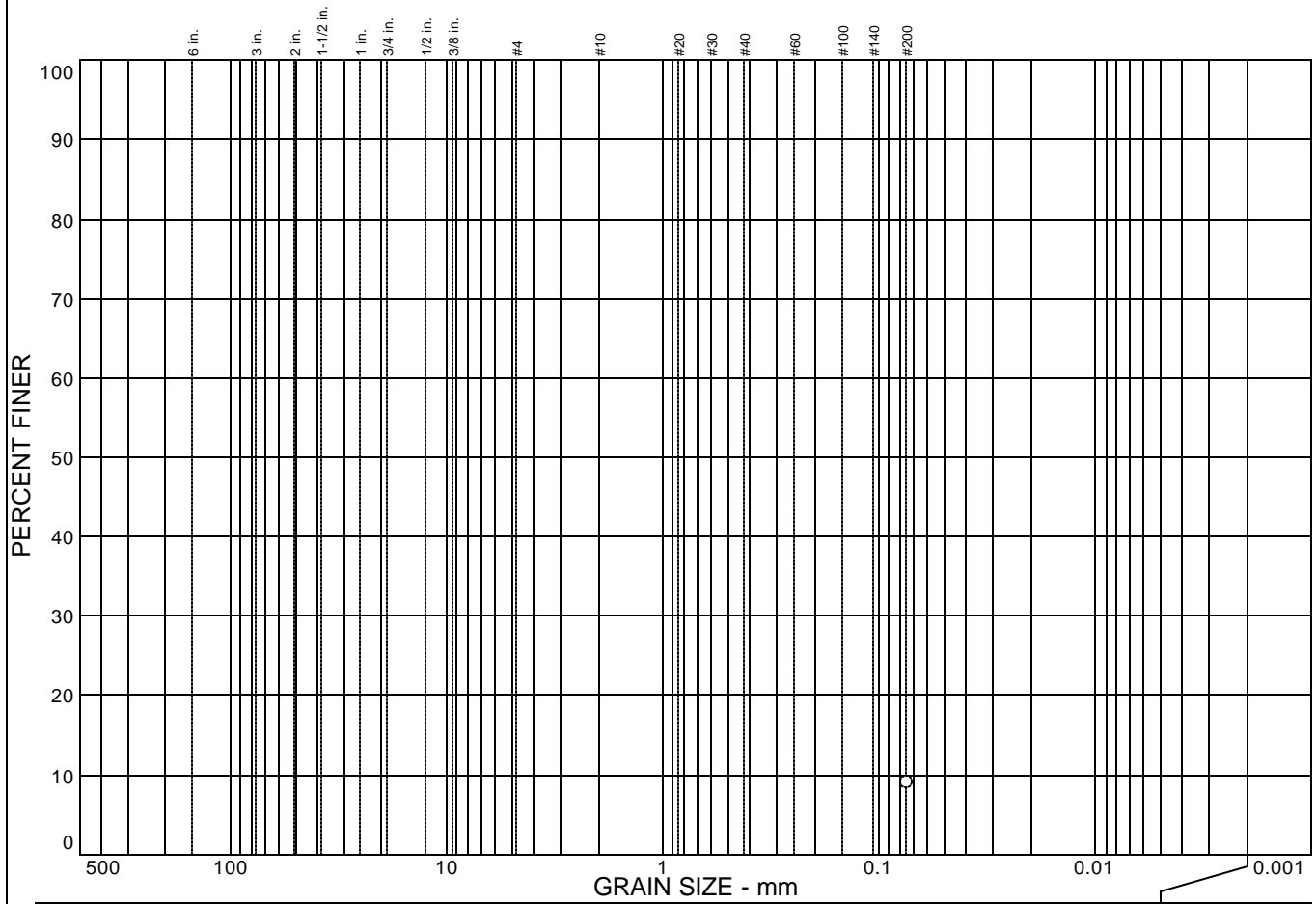

% COBBLES	% GRAVEL	% SAND	% SILT	% CLAY
			9.0	

SIEVE SIZE	PERCENT FINER	SPEC.* PERCENT	PASS? (X=NO)
#200	9.0		

Soil Description

Brownish yellow to brown SAND with trace silt

Atterberg Limits

PL= LL= PI=

Coefficients

D₈₅= D₆₀= D₅₀=
D₃₀= D₁₅= D₁₀=
C_u= C_c=

Classification

USCS= AASHTO=

Remarks

* (no specification provided)

Sample No.: B22 @ 16.0'
Location:

Source of Sample:

Date: 12/04/06
Elev./Depth: 16.0 feet



Client:
Project: Marina Coast Recycled Water Pipeline - Marina, CA

Project No.: 7496.1.001.01

Particle Size Distribution Report

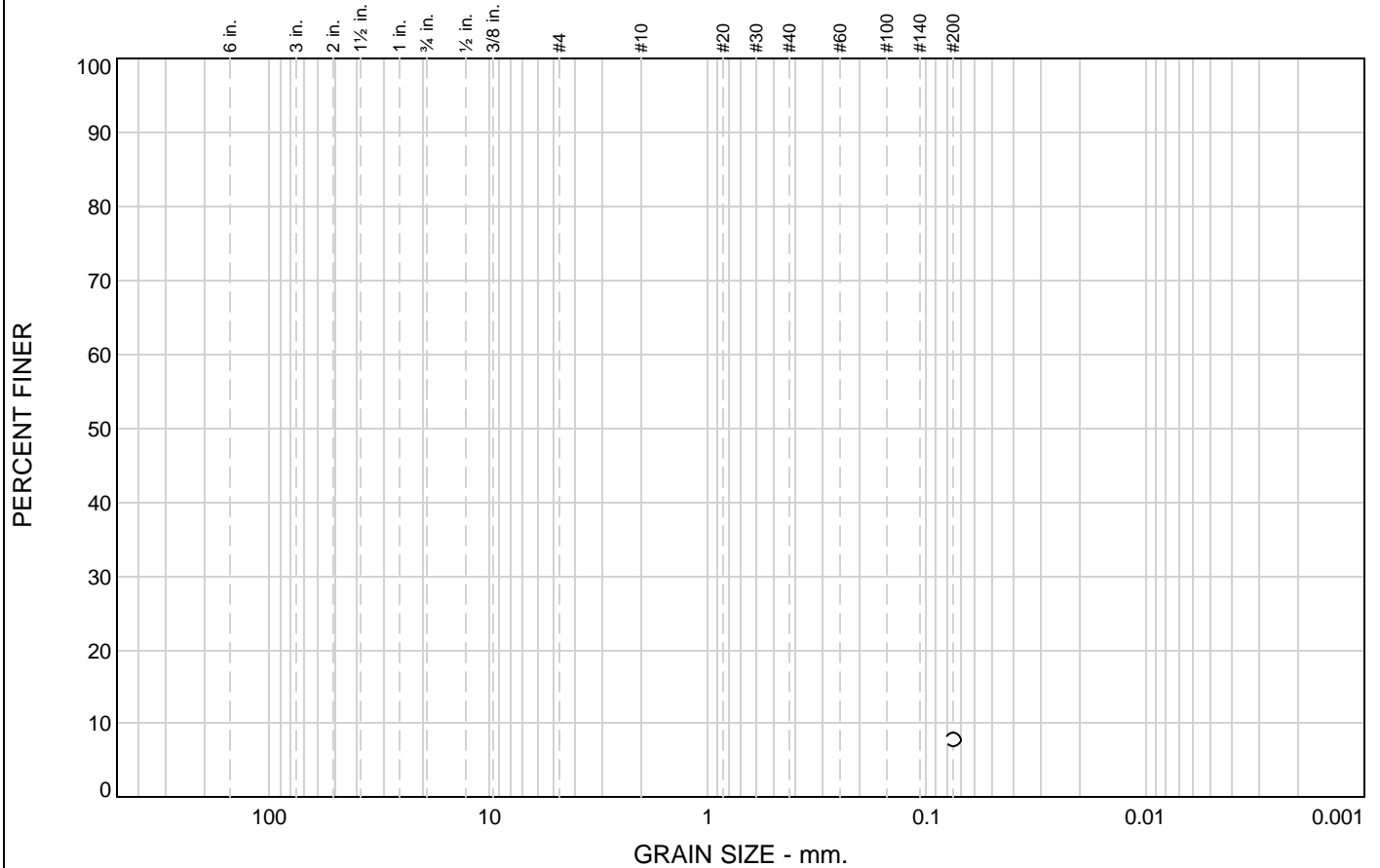

% +3"	% Gravel		% Sand			% Fines	
	Coarse	Fine	Coarse	Medium	Fine	Silt	Clay
						7.9	

SIEVE SIZE	PERCENT FINER	SPEC.* PERCENT	PASS? (X=NO)
#200	7.9		

Material Description

Brown SAND with silt.

Atterberg Limits

PL= LL= PI=

Coefficients

D₈₅= D₆₀= D₅₀=
D₃₀= D₁₅= D₁₀=
C_u= C_c=

Classification

USCS= AASHTO=

Remarks

* (no specification provided)

Sample Number: B5 @ 5.5-6.5'

Depth: 5.5-6.5 feet

Date: 08/02/07

Particle Size Distribution Report

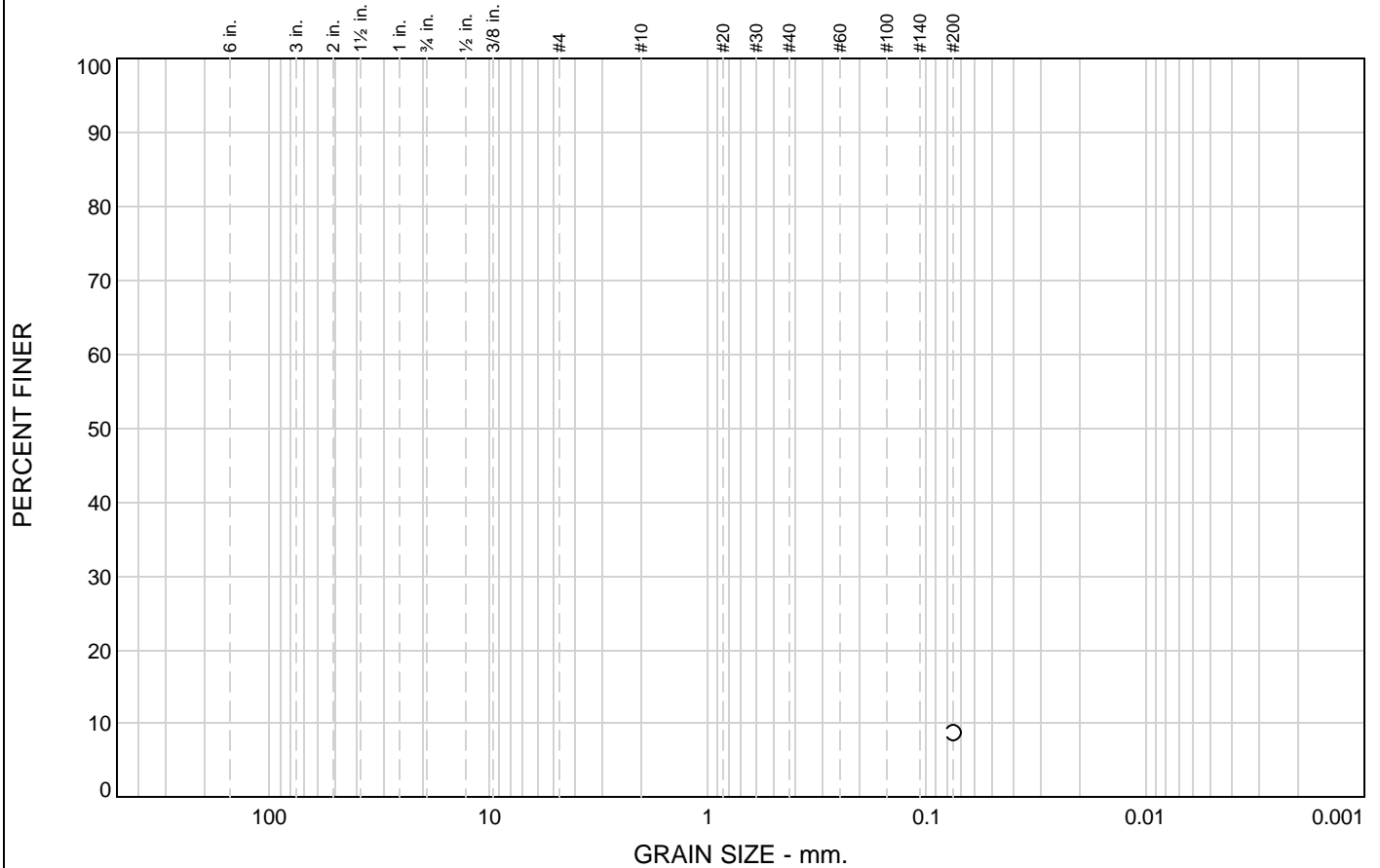

% +3"	% Gravel		% Sand			% Fines	
	Coarse	Fine	Coarse	Medium	Fine	Silt	Clay
						8.7	

SIEVE SIZE	PERCENT FINER	SPEC.* PERCENT	PASS? (X=NO)
#200	8.7		

Material Description

Brown SAND with silt.

Atterberg Limits

PL= LL= PI=

Coefficients

D₈₅= D₆₀= D₅₀=
D₃₀= D₁₅= D₁₀=
C_u= C_c=

Classification

USCS= AASHTO=

Remarks

* (no specification provided)

Sample Number: B5 @ 2.5-3.5' **Depth:** 2.5-3.5 feet **Date:** 08/02/7

Particle Size Distribution Report

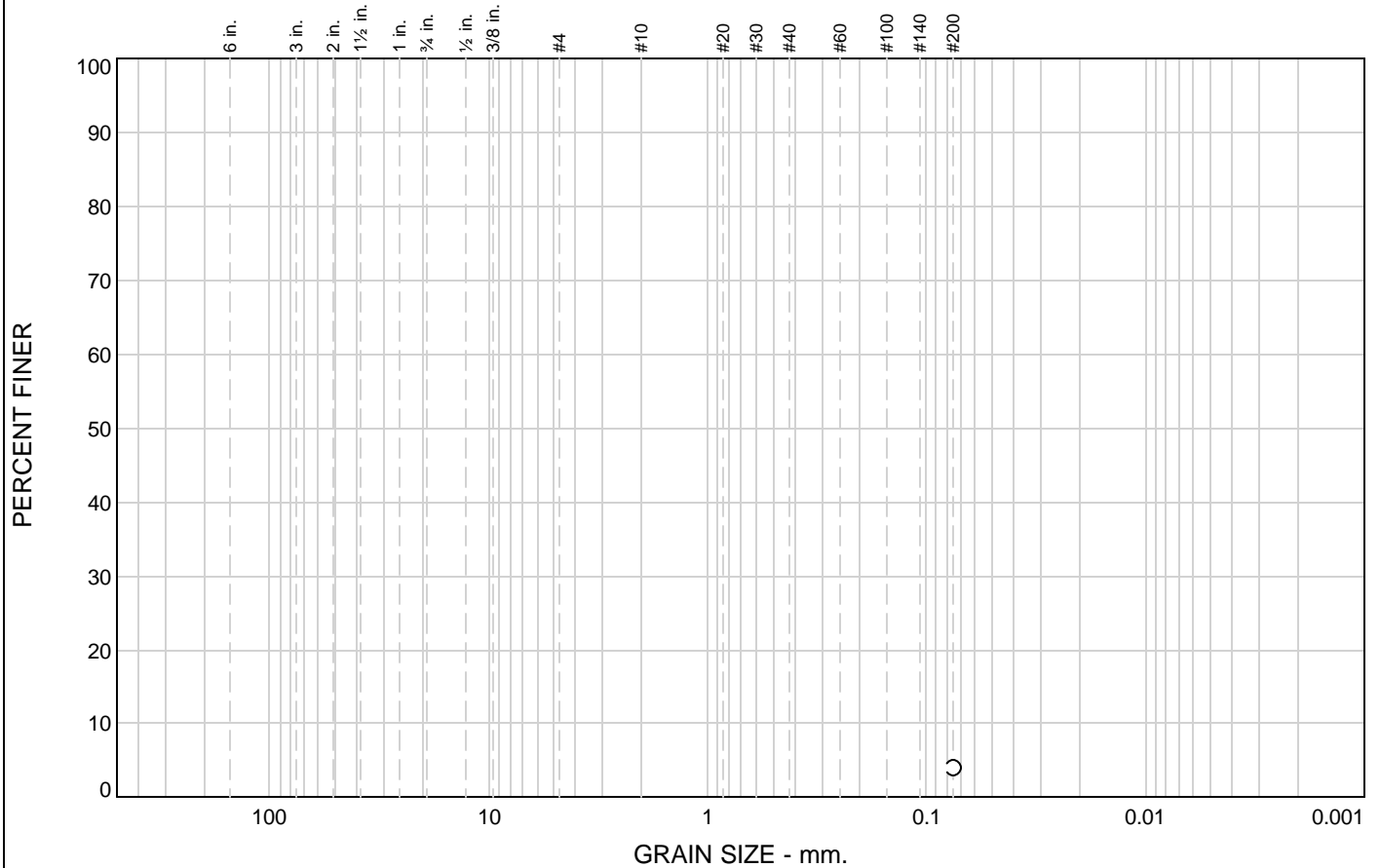

% +3"	% Gravel		% Sand			% Fines	
	Coarse	Fine	Coarse	Medium	Fine	Silt	Clay
						4.1	

SIEVE SIZE	PERCENT FINER	SPEC.* PERCENT	PASS? (X=NO)
#200	4.1		

Material Description

Light yellowish brown SAND. Trace silt.

Atterberg Limits

PL= LL= PI=

Coefficients

D₈₅= D₆₀= D₅₀=
D₃₀= D₁₅= D₁₀=
C_u= C_c=

Classification

USCS= AASHTO=

Remarks

* (no specification provided)

Sample Number: B4 @ 10.5-11.5' **Depth:** 10.5-11.5 feet **Date:** 08/02/07

Particle Size Distribution Report

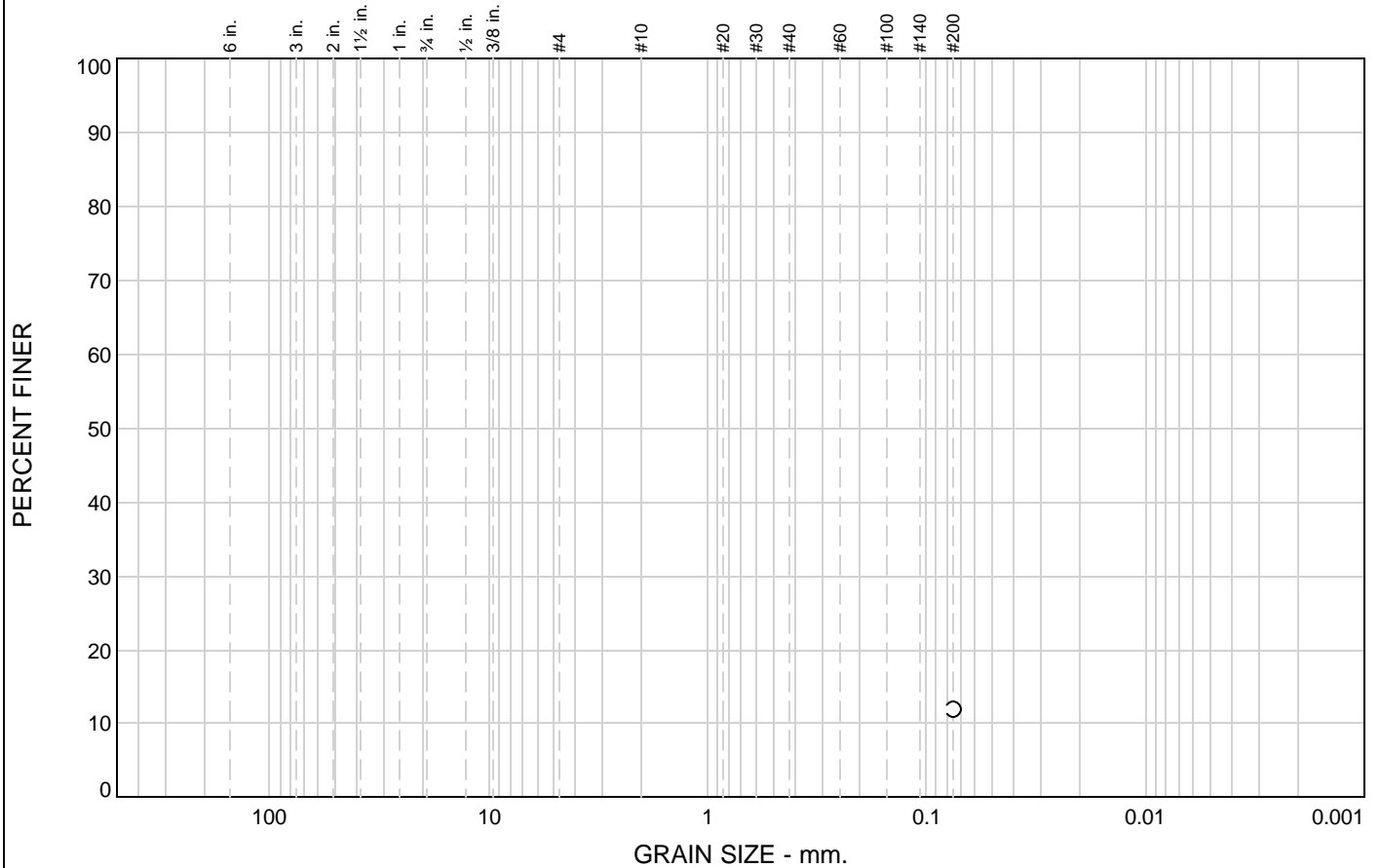

% +3"	% Gravel		% Sand			% Fines	
	Coarse	Fine	Coarse	Medium	Fine	Silt	Clay
							12.1

SIEVE SIZE	PERCENT FINER	SPEC.* PERCENT	PASS? (X=NO)
#200	12.1		

Material Description

Strong brown silty SAND.

Atterberg Limits

PL= LL= PI=

Coefficients

D₈₅= D₆₀= D₅₀=
D₃₀= D₁₅= D₁₀=
C_u= C_c=

Classification

USCS= SM AASHTO=

Remarks

* (no specification provided)

Sample Number: B4 @ 7.5-8.5'

Depth: 7.5-8.5 feet

Date: 08/02/07

<p style="font-size: small; margin: 0;"> GEOTECHNICAL AND ENVIRONMENTAL CONSULTANTS MATERIALS TESTING </p>	<p>Client:</p> <p>Project: MCWD (Line E and Ardenne Lateral) - Fort Ord</p> <p>Project No: 7496.1.003.01</p> <p style="text-align: right;">Plate</p>
---	--

Particle Size Distribution Report

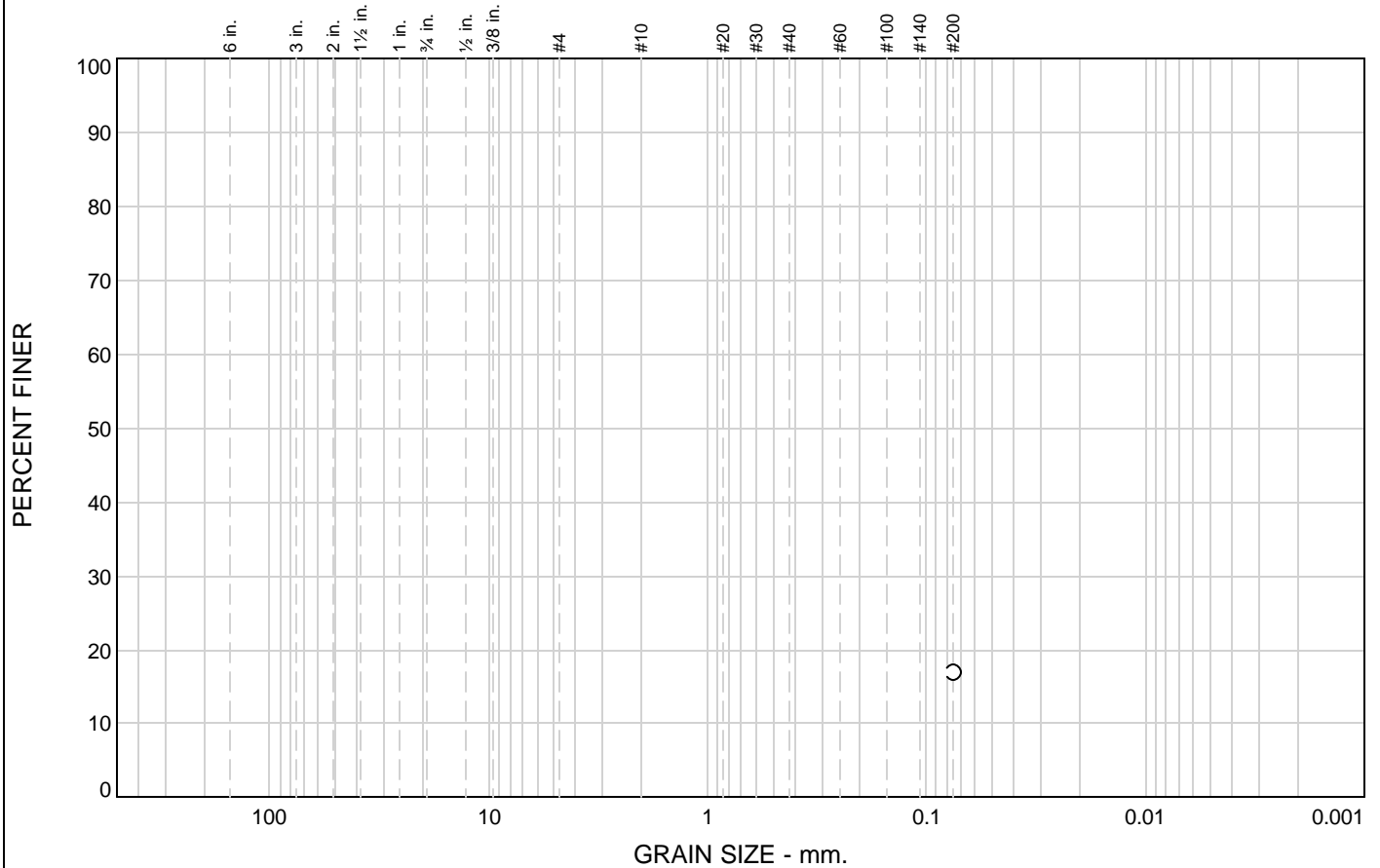

% +3"	% Gravel		% Sand			% Fines	
	Coarse	Fine	Coarse	Medium	Fine	Silt	Clay
						16.9	

SIEVE SIZE	PERCENT FINER	SPEC.* PERCENT	PASS? (X=NO)
#200	16.9		

Material Description

Brown silty SAND.

Atterberg Limits

PL= LL= PI=

Coefficients

D₈₅= D₆₀= D₅₀=
D₃₀= D₁₅= D₁₀=
C_u= C_c=

Classification

USCS= SM AASHTO=

Remarks

* (no specification provided)

Sample Number: B4 @ 2.5-3.5' **Depth:** 2.5-3.5 feet **Date:** 08/02/07

Particle Size Distribution Report

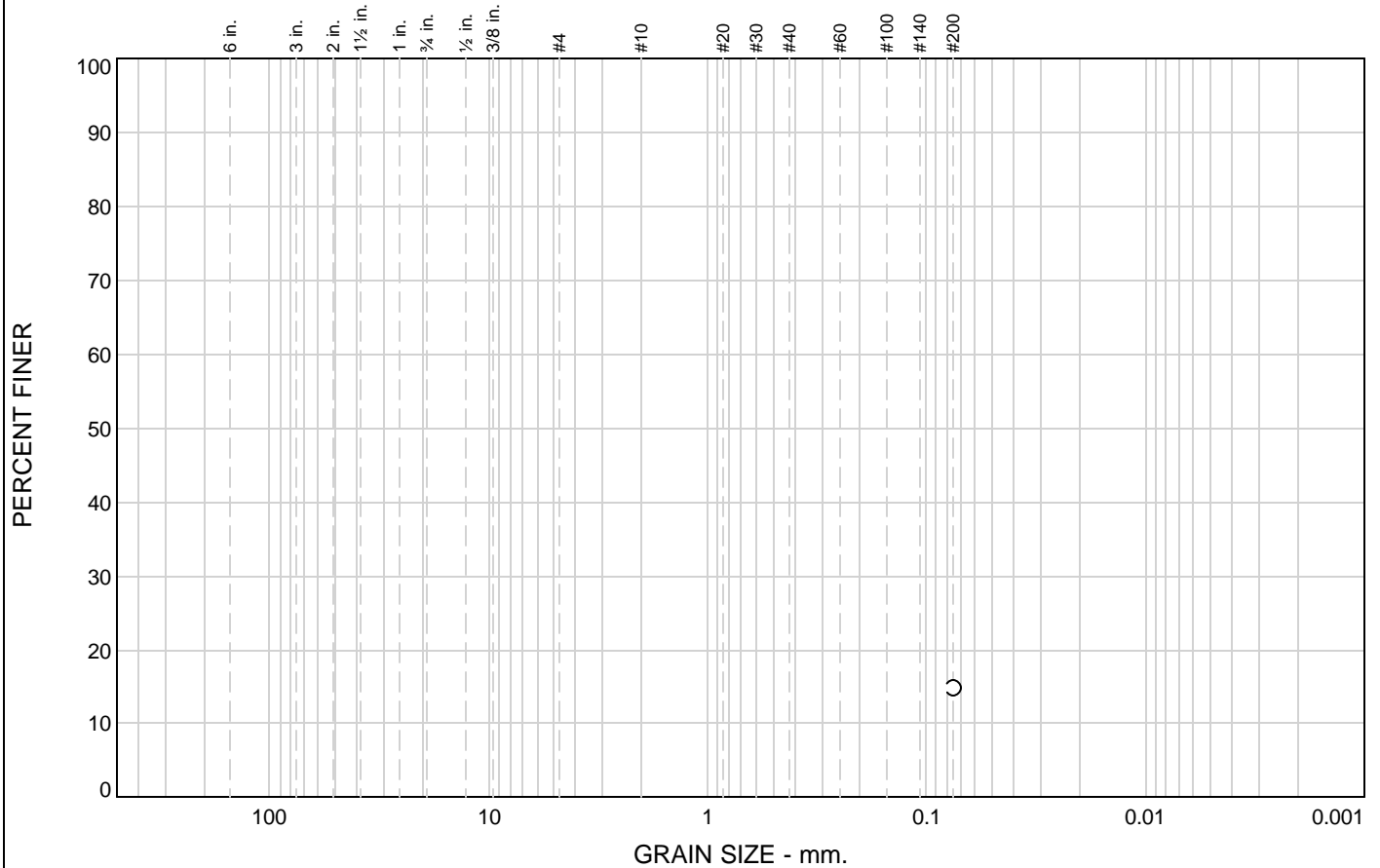

% +3"	% Gravel		% Sand			% Fines	
	Coarse	Fine	Coarse	Medium	Fine	Silt	Clay
						14.8	

SIEVE SIZE	PERCENT FINER	SPEC.* PERCENT	PASS? (X=NO)
#200	14.8		

Material Description

Strong brown silty SAND.

Atterberg Limits

PL= LL= PI=

Coefficients

D₈₅= D₆₀= D₅₀=
D₃₀= D₁₅= D₁₀=
C_u= C_c=

Classification

USCS= SM AASHTO=

Remarks

* (no specification provided)

Sample Number: B3 @ 10.5-11.5'

Depth: 10.5-11.5 feet

Date: 08/02/07

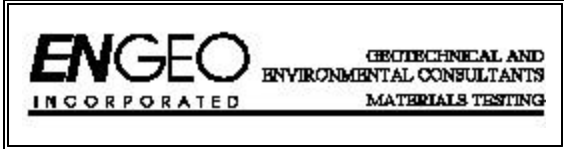

Client:
Project: MCWD (Line E and Ardenne Lateral) - Fort Ord
Project No: 7496.1.003.01
Plate

Particle Size Distribution Report

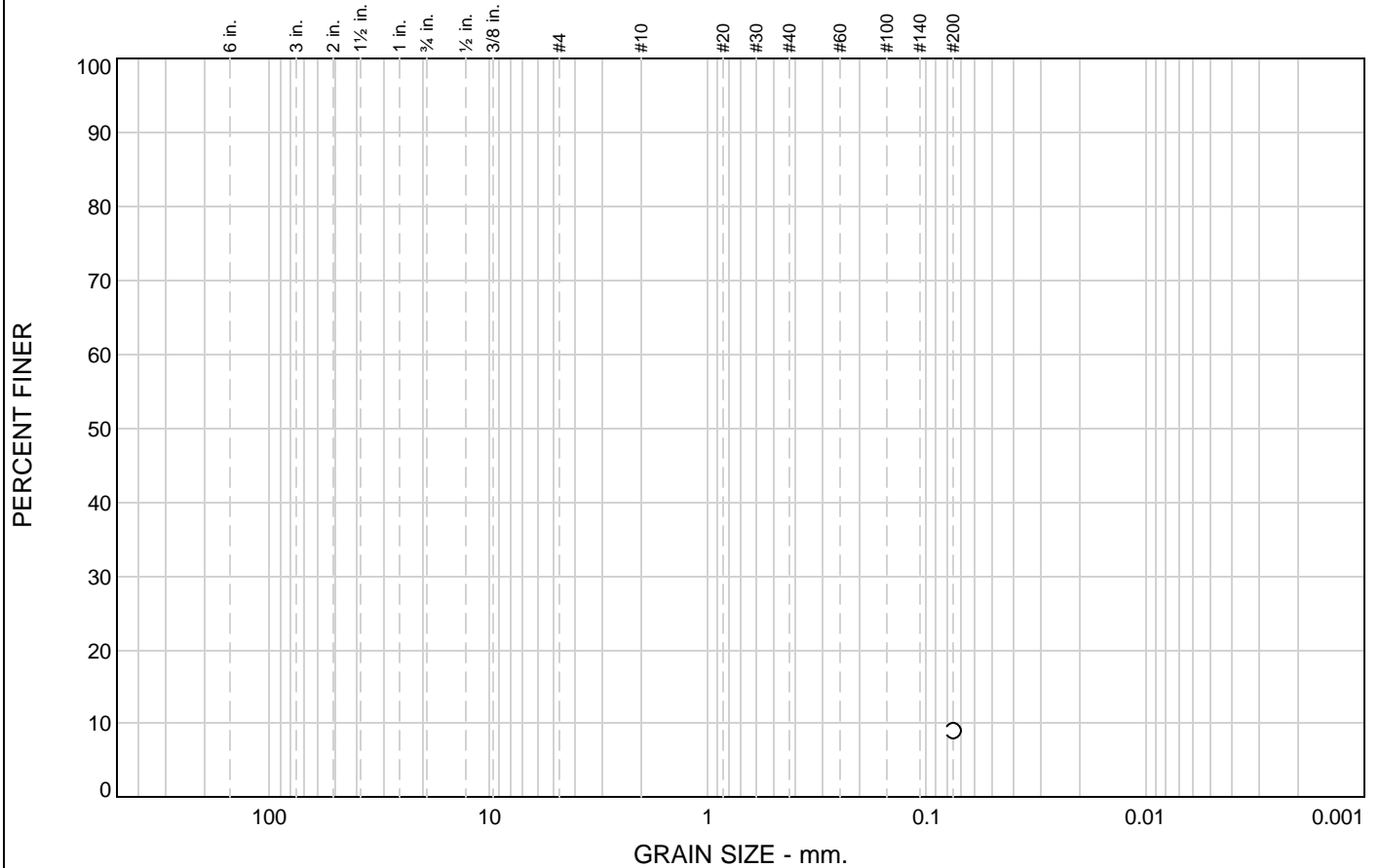

% +3"	% Gravel		% Sand			% Fines	
	Coarse	Fine	Coarse	Medium	Fine	Silt	Clay
						9.1	

SIEVE SIZE	PERCENT FINER	SPEC.* PERCENT	PASS? (X=NO)
#200	9.1		

Material Description

Yellowish brown SAND with silt.

Atterberg Limits

PL= LL= PI=

Coefficients

D₈₅= D₆₀= D₅₀=
D₃₀= D₁₅= D₁₀=
C_u= C_c=

Classification

USCS= AASHTO=

Remarks

* (no specification provided)

Sample Number: B3 @ 5.5-6.5'

Date: 08/02/07

Particle Size Distribution Report

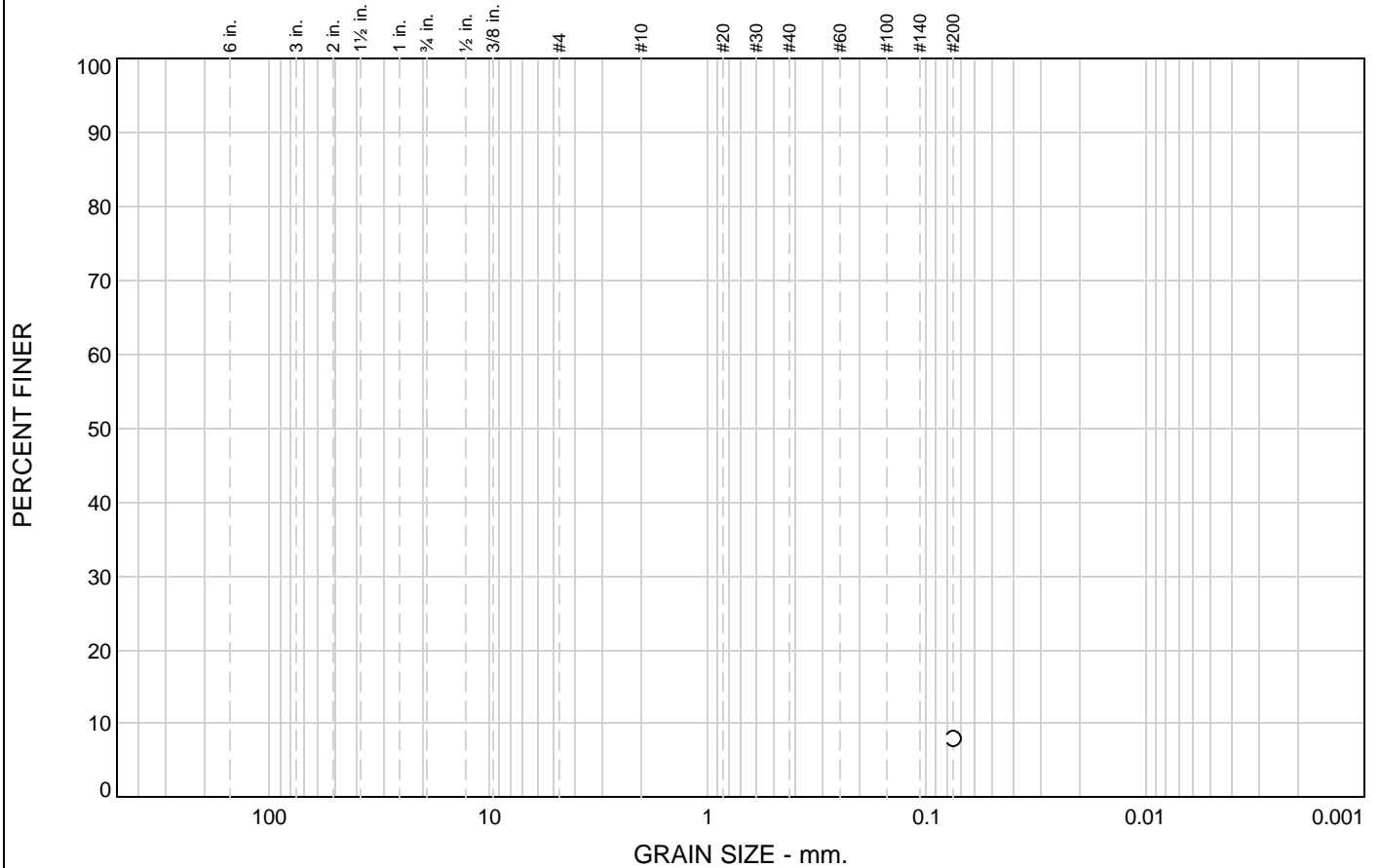

% +3"	% Gravel		% Sand			% Fines	
	Coarse	Fine	Coarse	Medium	Fine	Silt	Clay
						7.9	

SIEVE SIZE	PERCENT FINER	SPEC.* PERCENT	PASS? (X=NO)
#200	7.9		

Material Description

Brown SAND with silt.

Atterberg Limits

PL= LL= PI=

Coefficients

D₈₅= D₆₀= D₅₀=
D₃₀= D₁₅= D₁₀=
C_u= C_c=

Classification

USCS= AASHTO=

Remarks

* (no specification provided)

Sample Number: B3 @ 2.5-3.5' **Depth:** 2.5-3.5' **Date:** 08/02/07

Particle Size Distribution Report

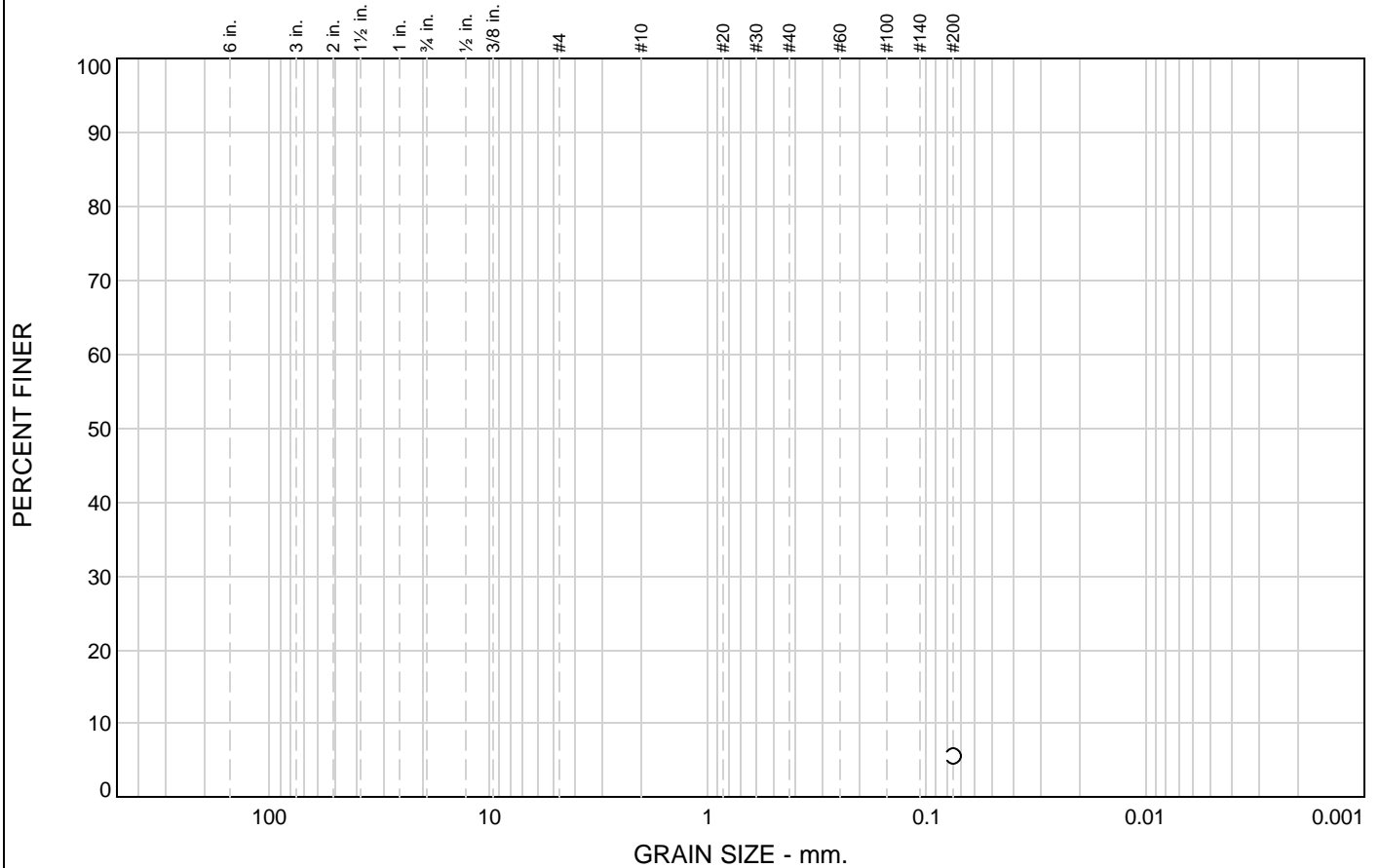

% +3"	% Gravel		% Sand			% Fines	
	Coarse	Fine	Coarse	Medium	Fine	Silt	Clay
						5.6	

SIEVE SIZE	PERCENT FINER	SPEC.* PERCENT	PASS? (X=NO)
#200	5.6		

Material Description

Yellow SAND with silt.

Atterberg Limits

PL= LL= PI=

Coefficients

D₈₅= D₆₀= D₅₀=
D₃₀= D₁₅= D₁₀=
C_u= C_c=

Classification

USCS= AASHTO=

Remarks

* (no specification provided)

Sample Number: B2 @ 10.5-11.5'

Depth: 10.5-11.5 feet

Date: 08/02/07

Particle Size Distribution Report

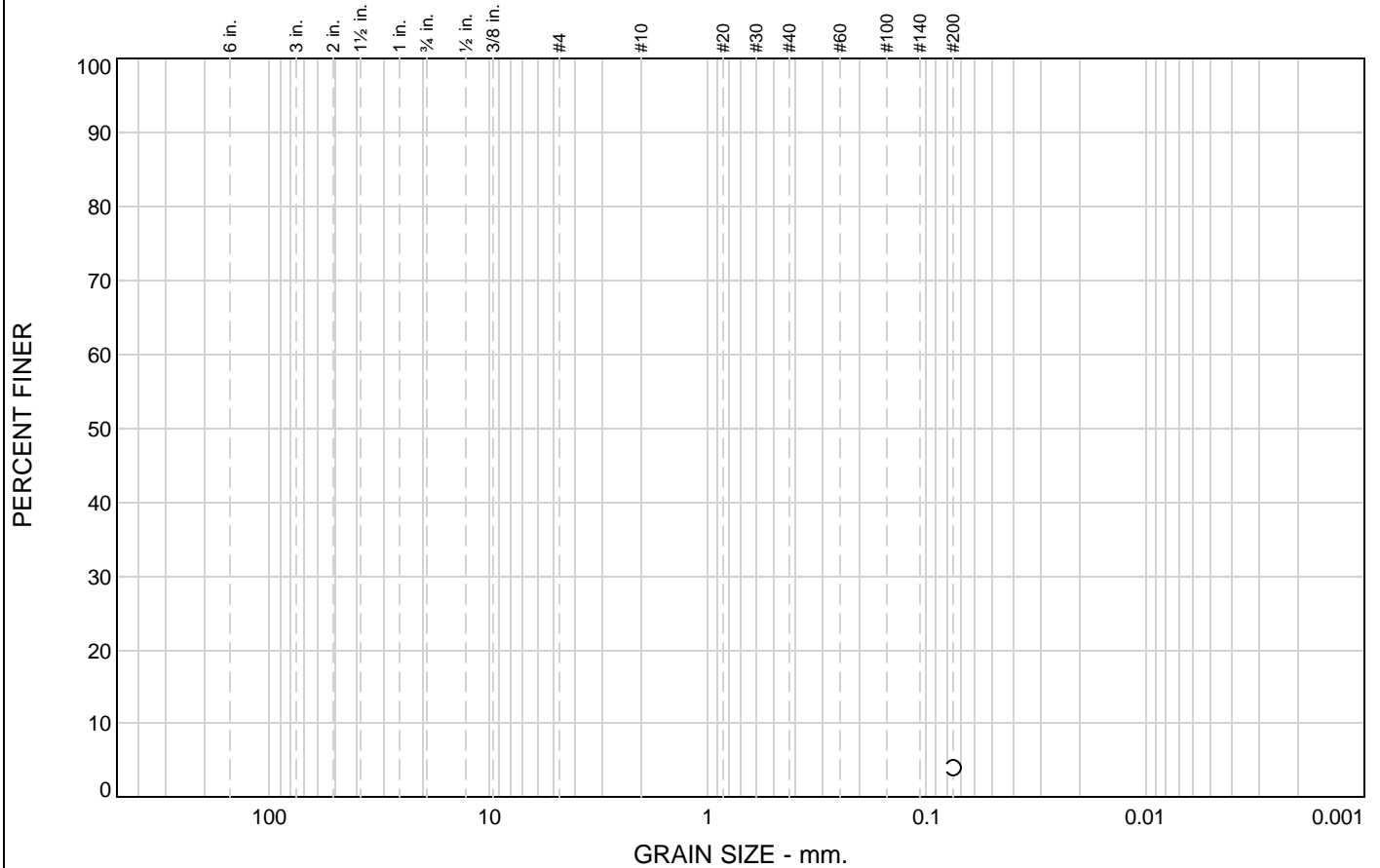

% +3"	% Gravel		% Sand			% Fines	
	Coarse	Fine	Coarse	Medium	Fine	Silt	Clay
						4.0	

SIEVE SIZE	PERCENT FINER	SPEC.* PERCENT	PASS? (X=NO)
#200	4.0		

Material Description

Brown SAND.

Atterberg Limits

PL= LL= PI=

Coefficients

D₈₅= D₆₀= D₅₀=
D₃₀= D₁₅= D₁₀=
C_u= C_c=

Classification

USCS= AASHTO=

Remarks

* (no specification provided)

Sample Number: B2 @ 5.5-6.5'

Depth: 5.5-6.5 feet

Date: 08/02/07

Particle Size Distribution Report

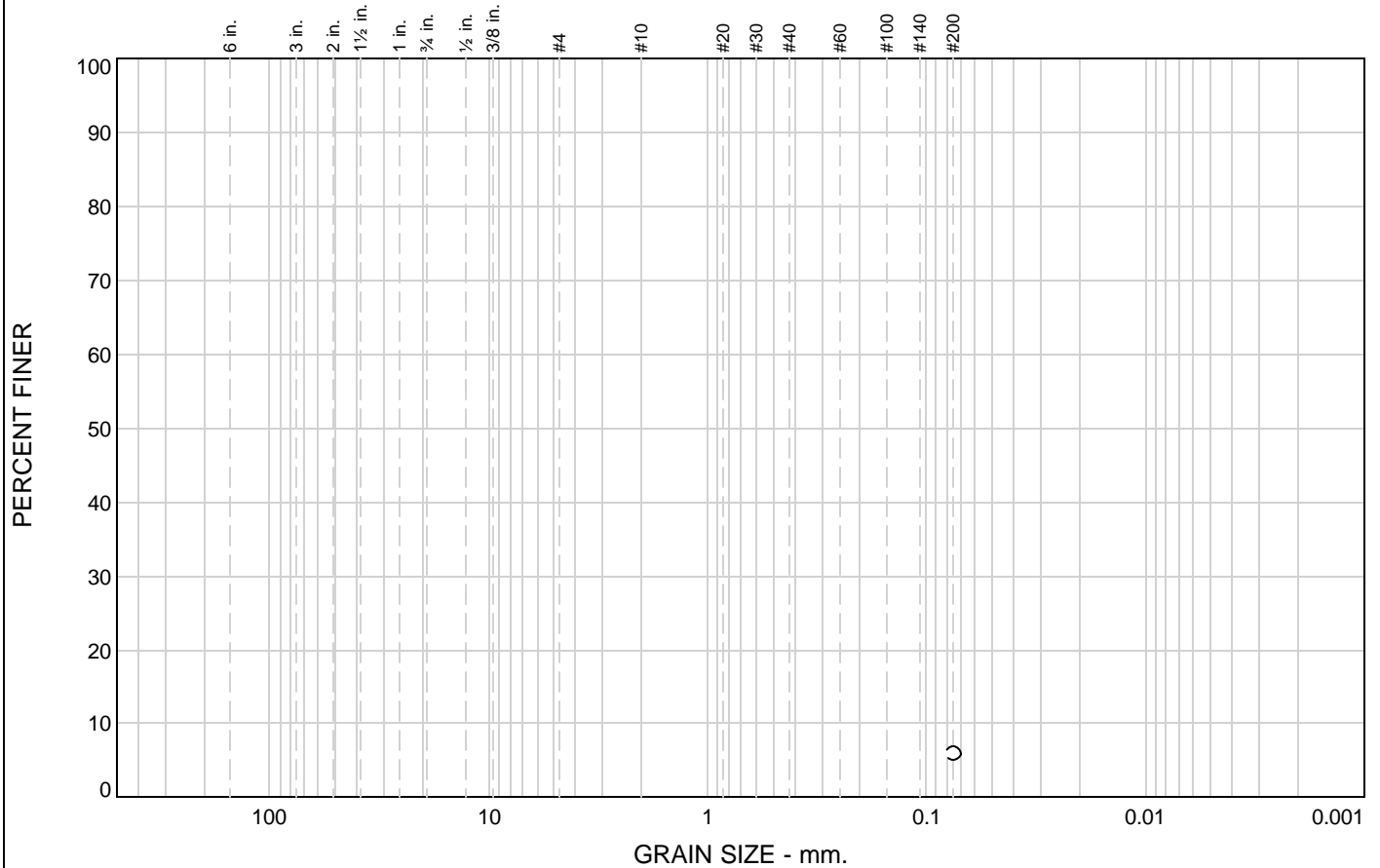

% +3"	% Gravel		% Sand			% Fines	
	Coarse	Fine	Coarse	Medium	Fine	Silt	Clay
						6.0	

SIEVE SIZE	PERCENT FINER	SPEC.* PERCENT	PASS? (X=NO)
#200	6.0		

Material Description

Very dark brown SAND with silt.

Atterberg Limits

PL= LL= PI=

Coefficients

D₈₅= D₆₀= D₅₀=
D₃₀= D₁₅= D₁₀=
C_u= C_c=

Classification

USCS= AASHTO=

Remarks

* (no specification provided)

Sample Number: B2 @ 2.5-3.5'

Depth: 2.5-3.5 feet

Date: 08/02/07

Particle Size Distribution Report

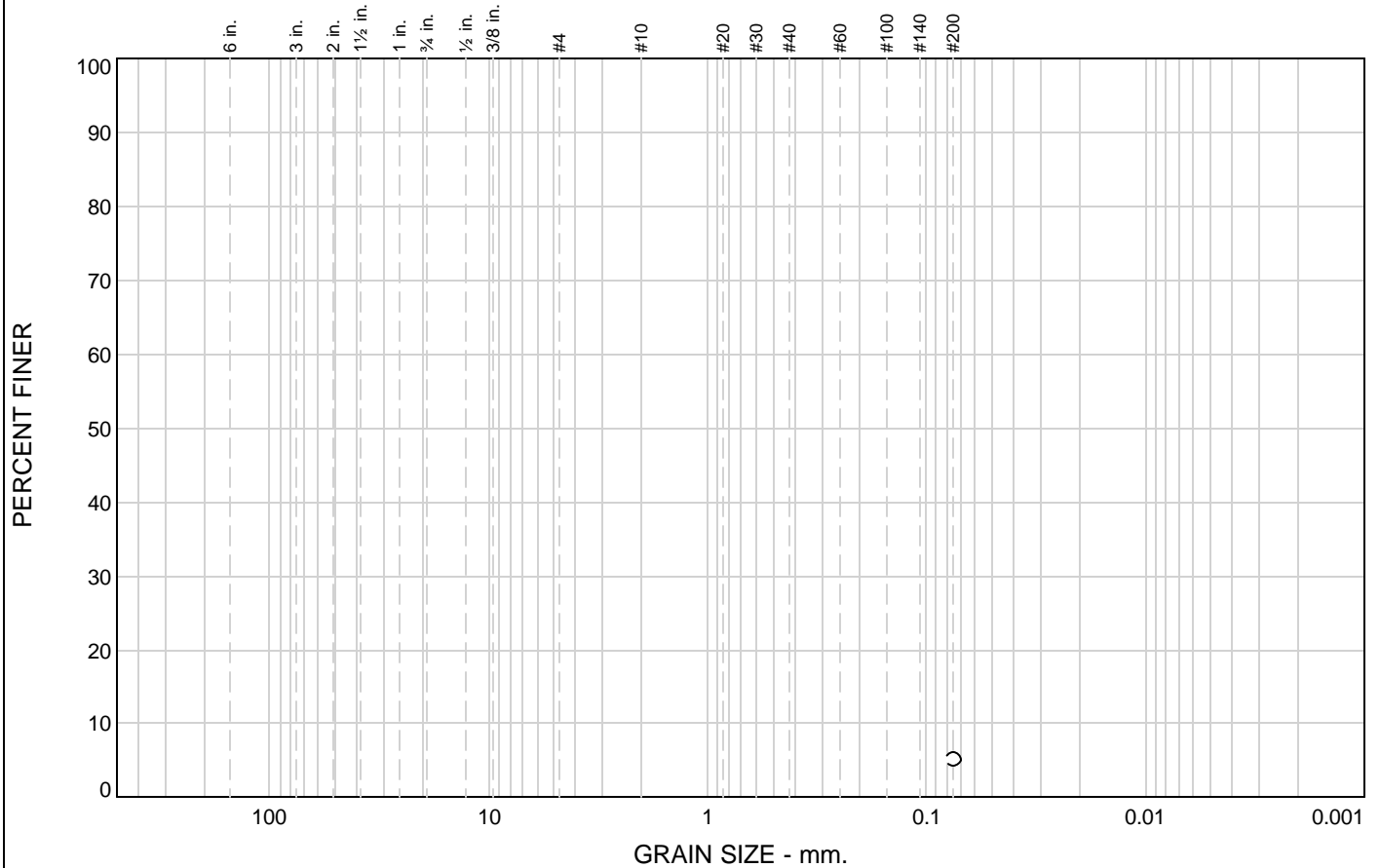

% +3"	% Gravel		% Sand			% Fines	
	Coarse	Fine	Coarse	Medium	Fine	Silt	Clay
						5.2	

SIEVE SIZE	PERCENT FINER	SPEC.* PERCENT	PASS? (X=NO)
#200	5.2		

Material Description

Strong brown SAND with silt.

Atterberg Limits

PL= LL= PI=

Coefficients

D₈₅= D₆₀= D₅₀=
D₃₀= D₁₅= D₁₀=
C_u= C_c=

Classification

USCS= AASHTO=

Remarks

* (no specification provided)

Sample Number: B1 @ 10.5-11.5'

Date: 08/02/07

Particle Size Distribution Report

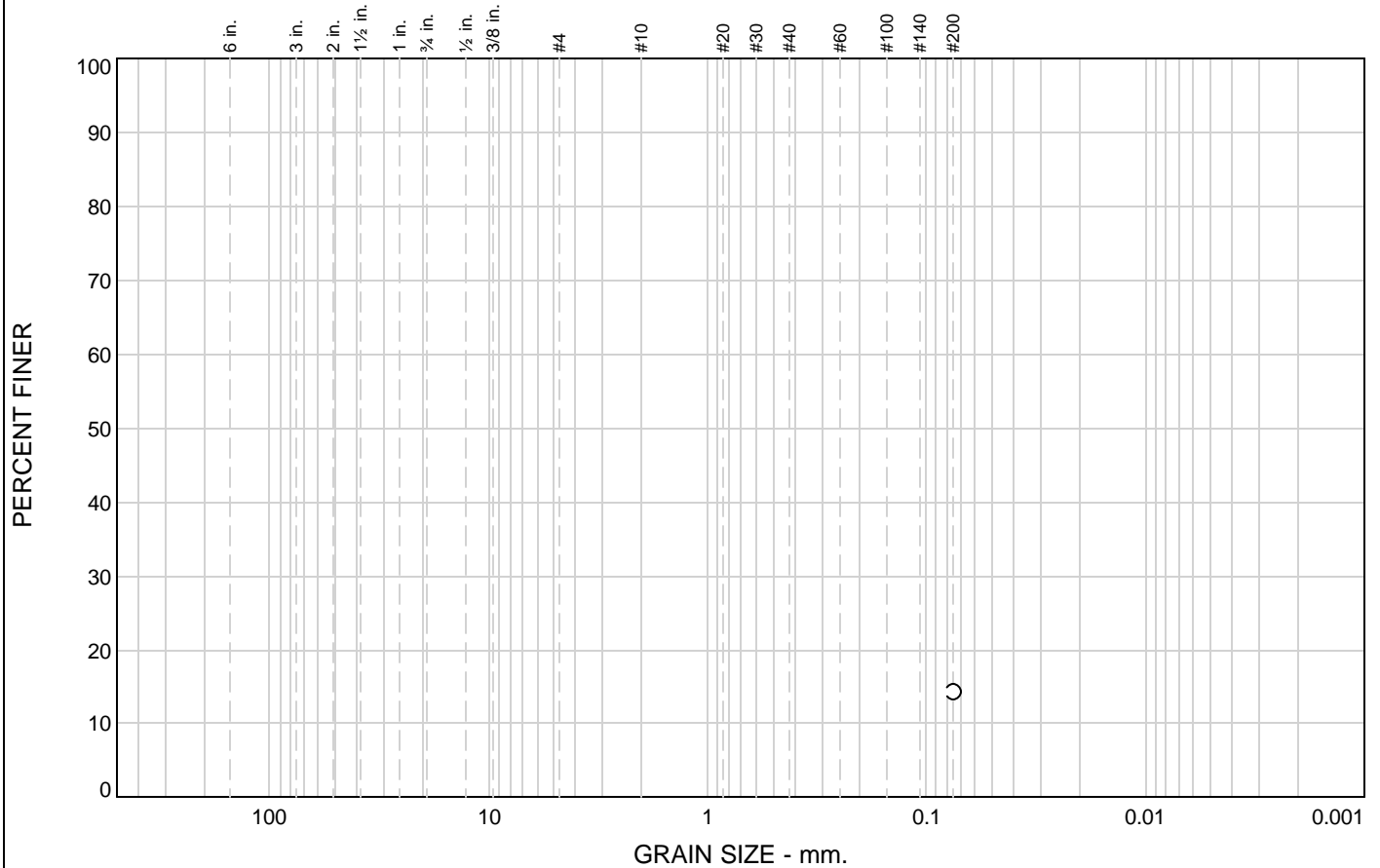

% +3"	% Gravel		% Sand			% Fines	
	Coarse	Fine	Coarse	Medium	Fine	Silt	Clay
						14.3	

SIEVE SIZE	PERCENT FINER	SPEC.* PERCENT	PASS? (X=NO)
#200	14.3		

Material Description

Dark brown silty SAND.

Atterberg Limits

PL= LL= PI=

Coefficients

D₈₅= D₆₀= D₅₀=
D₃₀= D₁₅= D₁₀=
C_u= C_c=

Classification

USCS= SM AASHTO=

Remarks

* (no specification provided)

Sample Number: B1 @ 5.5-6.5'

Date: 08/02/07

Particle Size Distribution Report

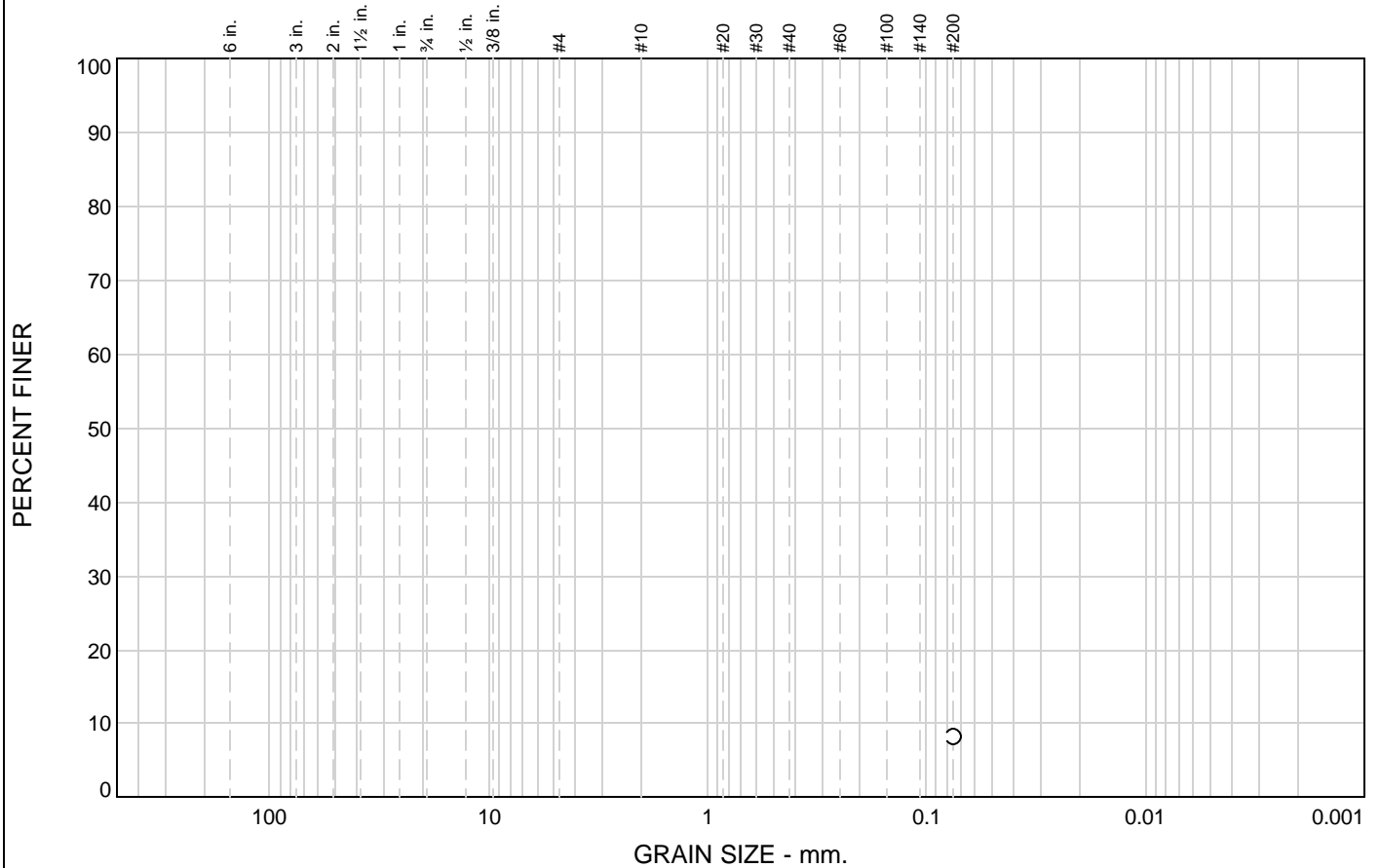

% +3"	% Gravel		% Sand			% Fines	
	Coarse	Fine	Coarse	Medium	Fine	Silt	Clay
						8.3	

SIEVE SIZE	PERCENT FINER	SPEC.* PERCENT	PASS? (X=NO)
#200	8.3		

Material Description

Brown SAND with silt.

Atterberg Limits

PL= LL= PI=

Coefficients

D₈₅= D₆₀= D₅₀=
D₃₀= D₁₅= D₁₀=
C_u= C_c=

Classification

USCS= AASHTO=

Remarks

* (no specification provided)

Sample Number: B1 @ 2.5-3.5' **Depth:** 2.5-3.5 feet **Date:** 08/02/07

Particle Size Distribution Report

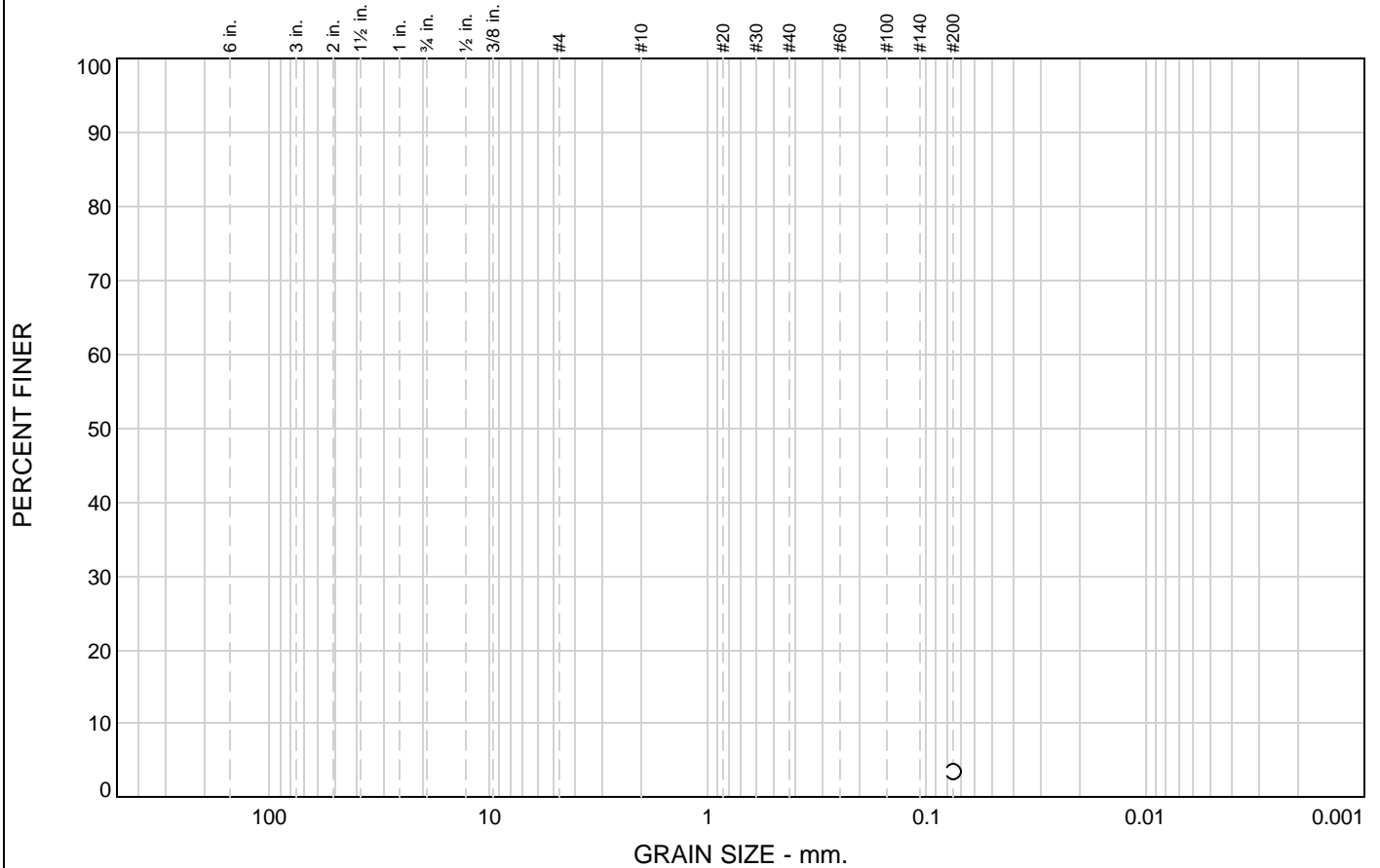

% +3"	% Gravel		% Sand			% Fines	
	Coarse	Fine	Coarse	Medium	Fine	Silt	Clay
						3.6	

SIEVE SIZE	PERCENT FINER	SPEC.* PERCENT	PASS? (X=NO)
#200	3.6		

Material Description

Strong brown SAND. Trace silt.

Atterberg Limits

PL= LL= PI=

Coefficients

D₈₅= D₆₀= D₅₀=
D₃₀= D₁₅= D₁₀=
C_u= C_c=

Classification

USCS= AASHTO=

Remarks

* (no specification provided)

Sample Number: B5 @ 10.5-11.5' **Depth:** 10.5-11.5 feet **Date:** 08/02/07

Particle Size Distribution Report

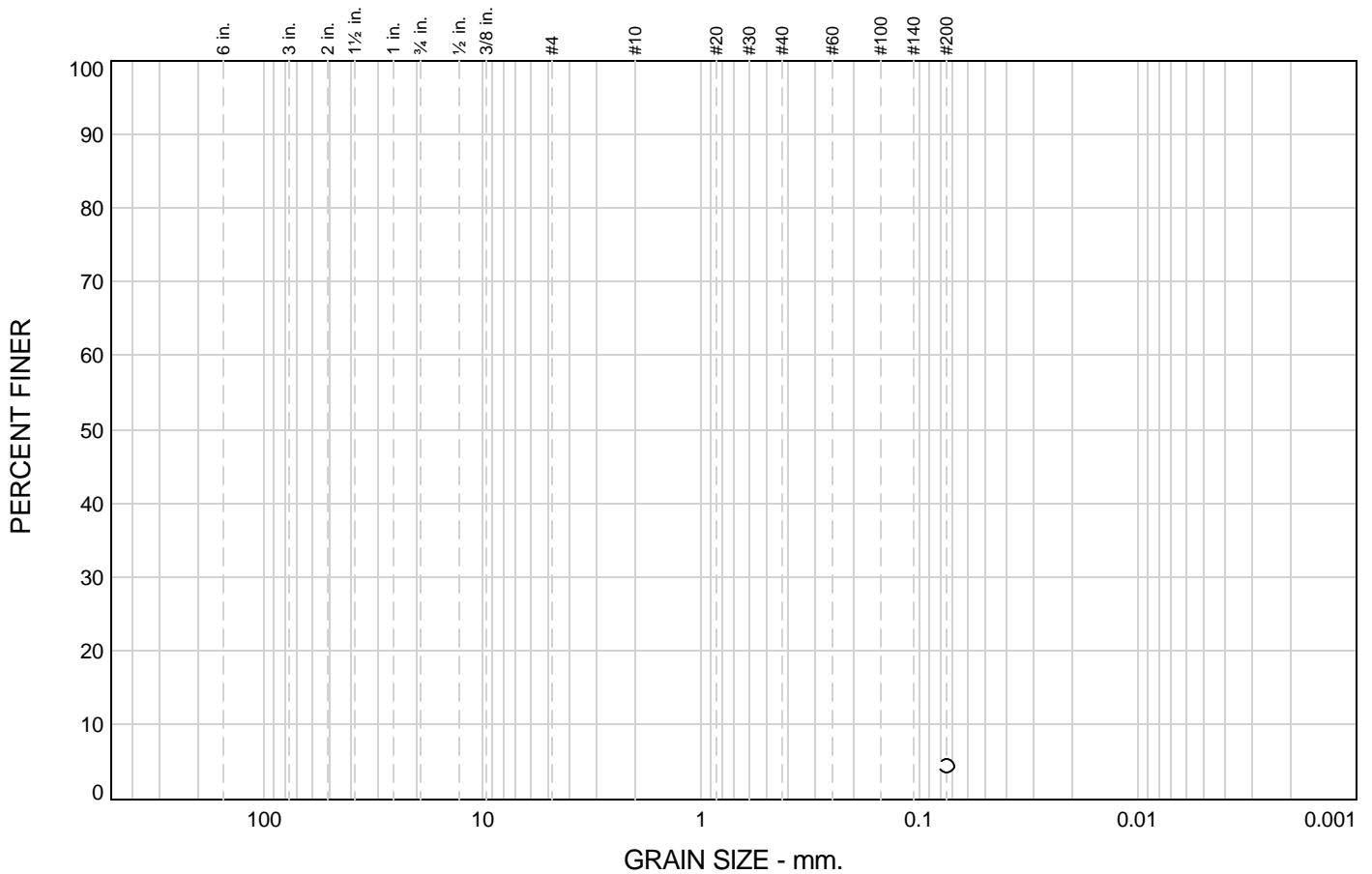

% Cobbles	% Gravel		% Sand			% Fines	
	Coarse	Fine	Coarse	Medium	Fine	Silt	Clay
						4.4	

SIEVE SIZE	PERCENT FINER	SPEC.* PERCENT	PASS? (X=NO)
#200	4.4		

Material Description

Very dark gray brown SAND. Trace silt.

Atterberg Limits

PL= LL= PI=

Coefficients

D₈₅= D₆₀= D₅₀=
 D₃₀= D₁₅= D₁₀=
 C_u= C_c=

Classification

USCS= AASHTO=

Remarks

* (no specification provided)

Sample Number: TP2 @ S-1

Date: 03/09/07



Client:
Project: Marina Coast Water District

Project No: 7496.1.001.01

Plate

Particle Size Distribution Report

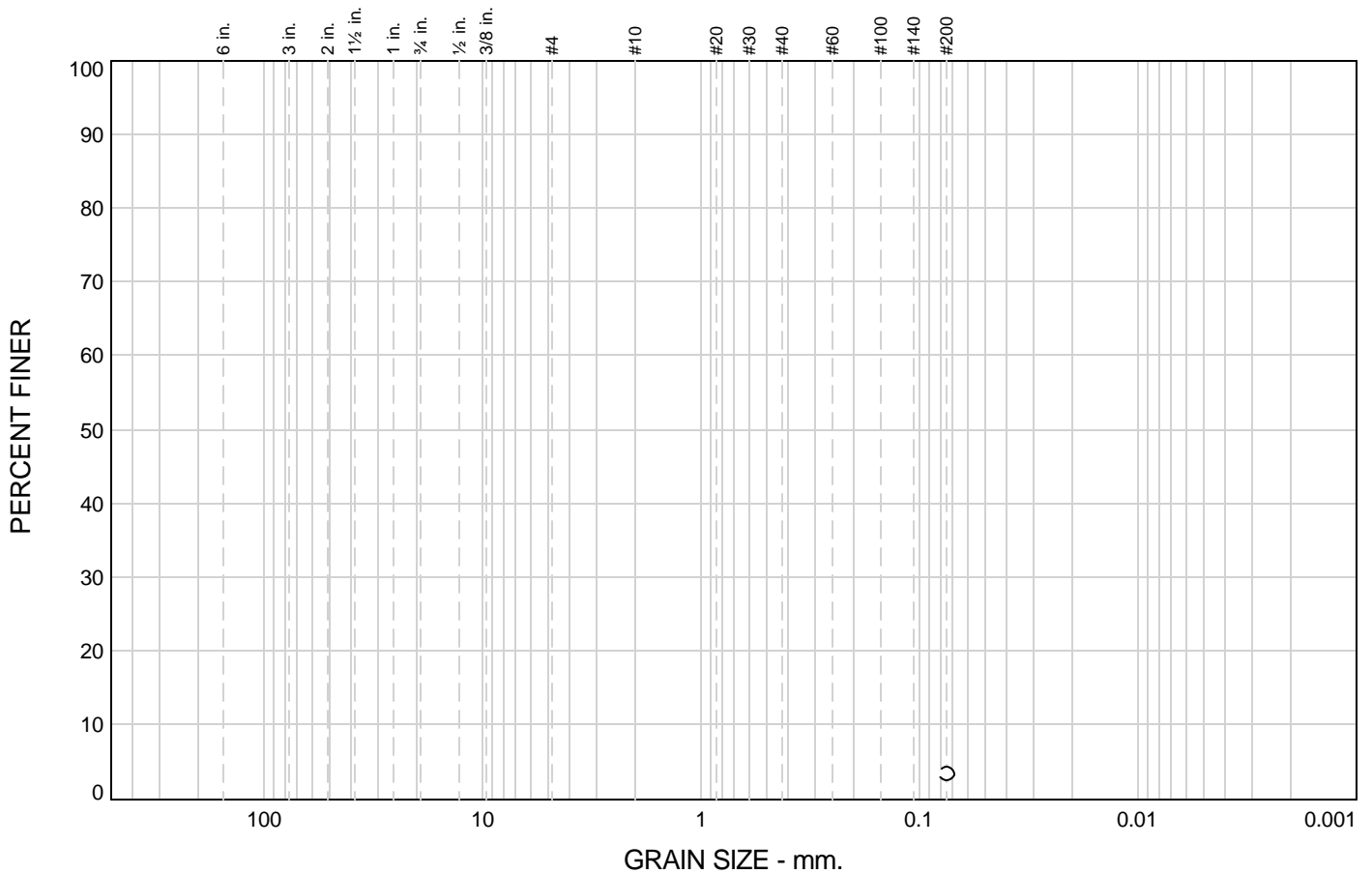

% Cobbles	% Gravel		% Sand			% Fines	
	Coarse	Fine	Coarse	Medium	Fine	Silt	Clay
						3.5	

SIEVE SIZE	PERCENT FINER	SPEC.* PERCENT	PASS? (X=NO)
#200	3.5		

Material Description

Yellowish brown SAND. Trace silt.

Atterberg Limits

PL= LL= PI=

Coefficients

D₈₅= D₆₀= D₅₀=
D₃₀= D₁₅= D₁₀=
C_u= C_c=

Classification

USCS= AASHTO=

Remarks

* (no specification provided)

Sample Number: TP1 @ S-2

Date: 03/09/07



Client:
Project: Marina Coast Water District

Project No: 7496.1.001.01

Plate

Particle Size Distribution Report

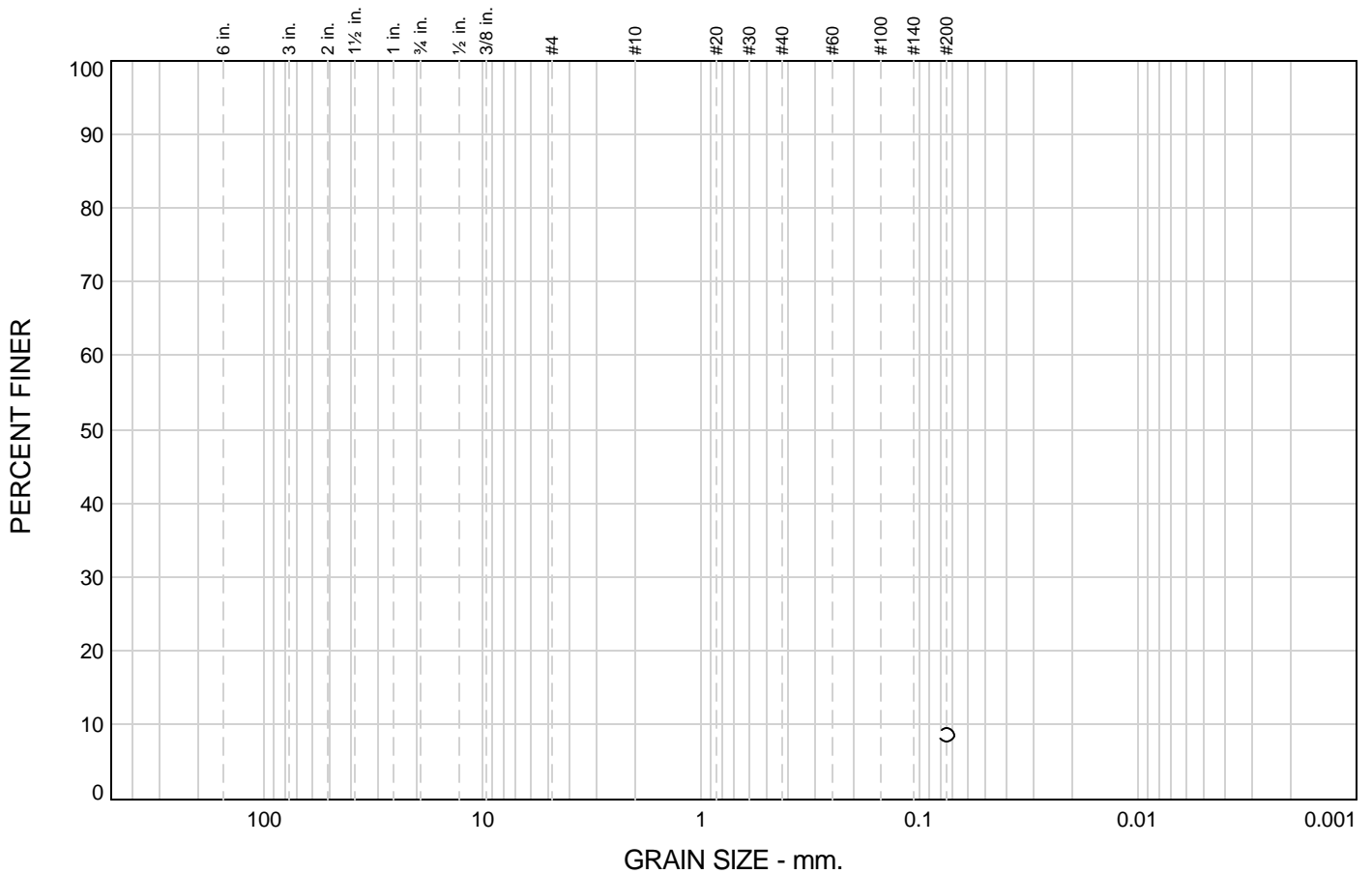

% Cobbles	% Gravel		% Sand			% Fines	
	Coarse	Fine	Coarse	Medium	Fine	Silt	Clay
						8.7	

SIEVE SIZE	PERCENT FINER	SPEC.* PERCENT	PASS? (X=NO)
#200	8.7		

Material Description

Dark brown SAND with some silt.

Atterberg Limits

PL= LL= PI=

Coefficients

D₈₅= D₆₀= D₅₀=
D₃₀= D₁₅= D₁₀=
C_u= C_c=

Classification

USCS= AASHTO=

Remarks

* (no specification provided)

Sample Number: TP1 @ S-1

Date: 03/09/07



Client:
Project: Marina Coast Water District

Project No: 7496.1.001.01

Plate

Particle Size Distribution Report

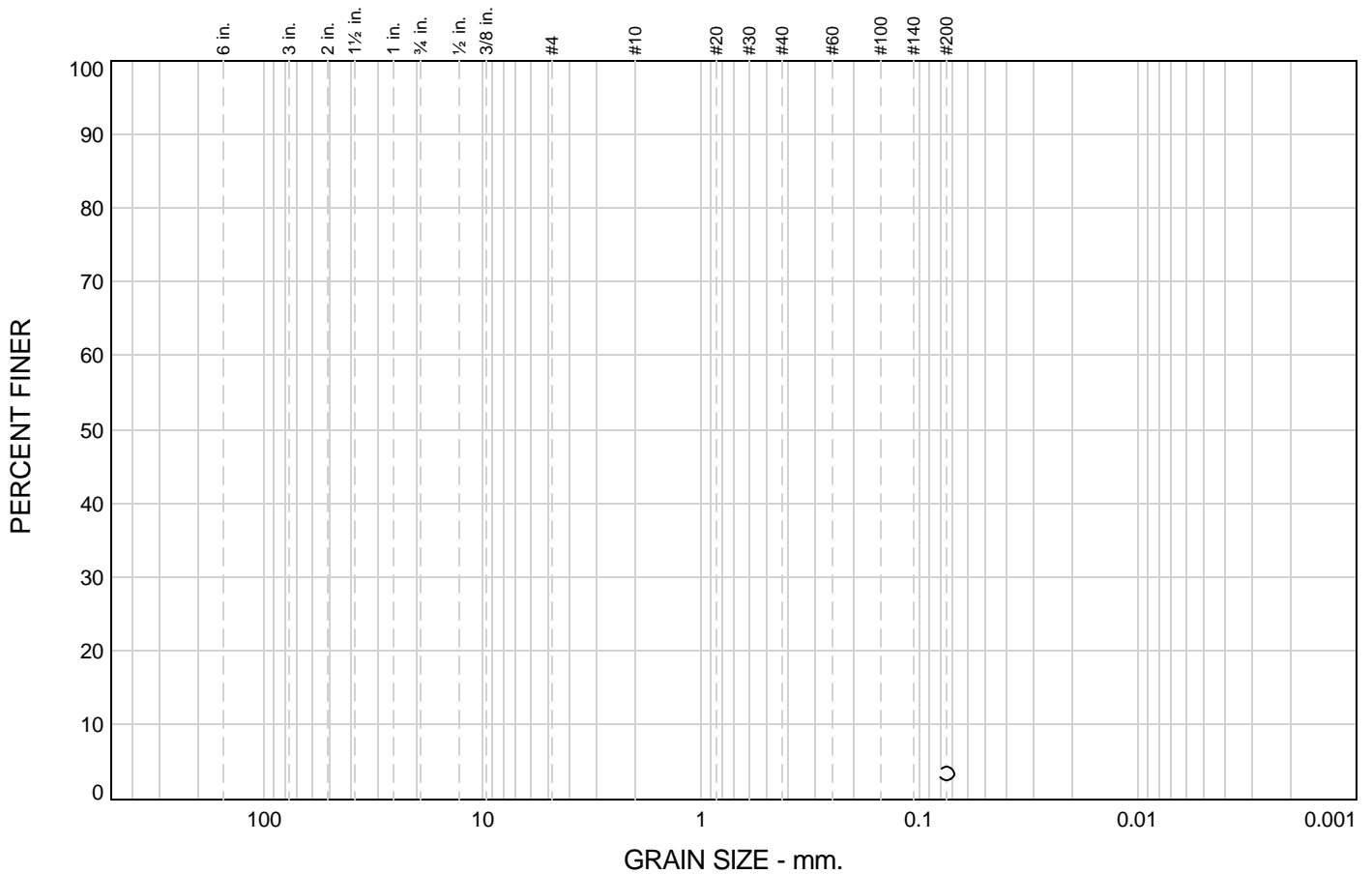

% Cobbles	% Gravel		% Sand			% Fines	
	Coarse	Fine	Coarse	Medium	Fine	Silt	Clay
						3.5	

SIEVE SIZE	PERCENT FINER	SPEC.* PERCENT	PASS? (X=NO)
#200	3.5		

Material Description

Brown SAND. Trace silt.

Atterberg Limits

PL= LL= PI=

Coefficients

D₈₅= D₆₀= D₅₀=
D₃₀= D₁₅= D₁₀=
C_u= C_c=

Classification

USCS= AASHTO=

Remarks

* (no specification provided)

Sample Number: TP2 @ S-2

Date: 03/09/07



Client:
Project: Marina Coast Water District

Project No: 7496.1.001.01

Plate

ENGEO
INCORPORATED

JOB NAME:	Marina Coast Water District
JOB NO.	7496.1.001.01
DATE:	03/09/07
BY:	KM

MOISTURE CONTENT DETERMINATION

SAMPLE NO:	TP1 @ S1	TP1 @ S2	TP2 @ S1	TP2 @ S2				
TARE NUMBER	BUZZ	GXW	JKL	ABC				
GROSS WET WT.	1034.8	1214.7	1005.6	1086.6				
GROSS DRY WT.	980.5	1173.1	938.6	1060.1				
TARE WEIGHT	218.4	225.0	216.7	222.1				
NET DRY WT.	762.1	948.1	721.9	838.0				
WT. OF WATER	54.3	41.6	67.0	26.5				
% MOISTURE	7.1%	4.4%	9.3%	3.2%				



Job name: MCWD (Line E & Ardenne Lateral)
Job number: 7496.1.003.01
Date: August 1, 2007

Moisture Content Determination

Sample number:	B1@3.5	B1@6.5	B1@11.5	B2@3.5	B2@6.5	B2@11.5	B3@3.5	B3@6.5
% Moisture:	5.3	5.7	3.9	4.4	4.3	4.3	3.9	5.9

Sample number:	B3@11.5	B4@3.5	B4@8.5	B4@11.5	B5@3.5	B5@6.5	B5@11.5	
% Moisture:	5.2	1.9	8.6	4.9	1.9	1.5	3.8	

APPENDIX C

Existing Information on Enclosed CD

CT 1970 – Reservation Road Undercrossing, soil logs obtained from Cal Trans District 5, 1970.

D & M 1999 – Report of Geotechnical Investigation, 12th Street Gateway/2nd Avenue Realignment, Former Fort Ord, Marina and Seaside, California, Prepared by D & M Consulting Engineers, Inc., November 1999.

DCM 2006 – Geotechnical Engineering Investigation Report, Marina Coast Water District, 2005 Marina Sewer Improvement Projects, Marina, California, Prepared by DCM Engineering, August 2006.

FG 2004 – Geotechnical Study, California State University Monterey Bay, North Campus Housing, Monterey County, California, Prepared by Fugro West Inc., March 2004.

GCI 1979 – Geotechnical Investigation, Phase II, Regional Wastewater Management System, Stage II, Monterey County, California, Prepared by Geotechnical Consultants Inc., April 1979.

HLA 1999 – Test Pit Logs Obtained From Fort Ord Reuse Authority, Logged by Harding Lawson Associates, November 1999, Location Maps Included.

KF 2005 – Geotechnical Investigation Proposed East Garrison, “B” Zone Tanks, “D” Zone Reservoirs, “E” Zone Hydropneumatic Pump Station, and Transmission Mains, Marina Coast Water District, Marina, California, Prepared by Kleinfelder Inc., September 28, 2005.

KF 2006 Updated Geotechnical Investigation, Proposed Library, California State University Monterey Bay, Seaside, California, Prepared by Kleinfelder Inc., May 18, 2006.

PCE 2004 – Geotechnical Investigation for General Jim Moore Boulevard and Eucalyptus Road, Seaside, California, Prepared by Pacific Crest Engineering Inc., February 2004.

APPENDIX D (Continued)

Existing Information on Enclosed CD

- SH 2006 – Draft Well Installation Completion Report, Armstrong Ranch, Operable Unit 1, Former Fort Ord, California, Total Environmental Restoration Contract, Contract No. DACW05-96-D-0011, Prepared by Shaw Environmental Group Inc., September 2006.
- Site 11 – HLA. 1994. Harding Lawson Associates. Volume II - Remedial Investigation. Basewide Surface Water Outfall Investigation. Final. October 19, 1995.
- Site 16 & 17 – HLA. 1994. Harding Lawson Associates. Volume II - Remedial Investigation. Sites 16 and 17. Final. October 19, 1995.
- Site 18 – HLA. 1994. Harding Lawson Associates. Volume IV - Baseline Ecological Risk Assessment. Final. October 19, 1995.
- Site 25 – HLA. 1994. Harding Lawson Associates. Volume IV - Baseline Ecological Risk Assessment. Final. October 19, 1995.
- Site 26 – HLA. 1994. Harding Lawson Associates. Volume IV - Baseline Ecological Risk Assessment. Final. October 19, 1995.
- Site 27 – HLA. 1994. Harding Lawson Associates. Volume IV - Baseline Ecological Risk Assessment. Final. October 19, 1995.
- TT 1997 – Boring Logs Obtained From Fort Ord Reuse Authority, Logged by TerraTech Inc., February 1997, Location maps unavailable.
- TW 2004 – Geotechnical Engineering Investigation Report, Proposed Fitch Park Military Housing, Fort Ord Military Reservation, Seaside, Monterey County, California, Prepared by Twining Laboratories, Inc., November 12, 2004.

Cal Trans 1970¹

¹ Please See Figure 5 for full Citation

PACIFIC OCEAN

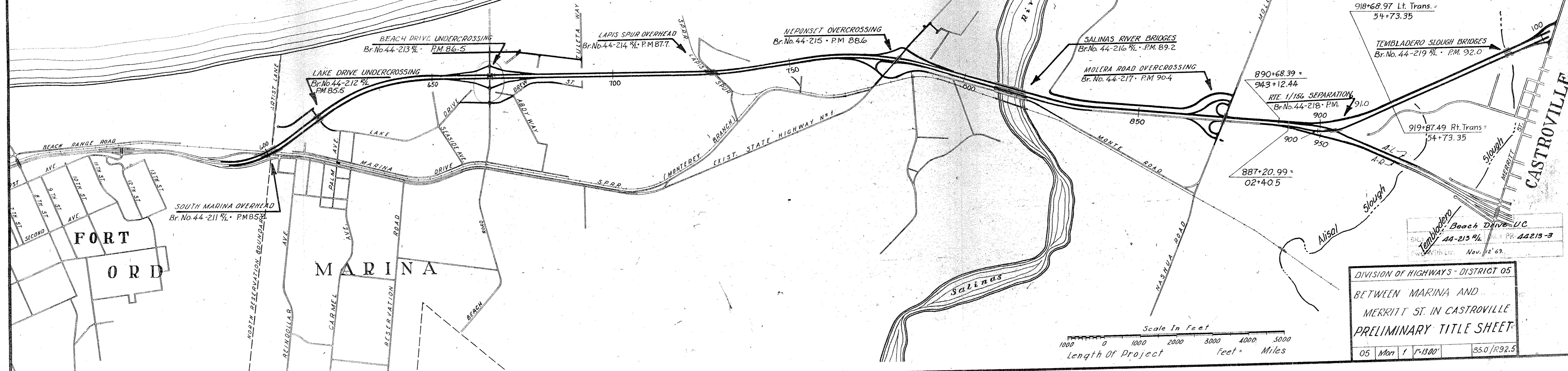

FORT FORD

MARINA

CASTROVILLE

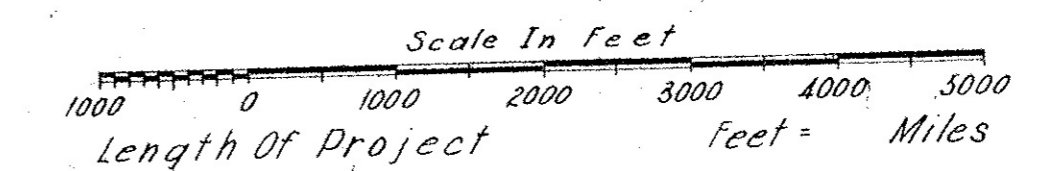

918+68.97 Lt. Trans. = 54+73.35

TEMLADERO SLOUGH BRIDGES
Br. No. 44-219 1/2 · P.M. 92.0

890+68.39 = 943+12.44
RTE. 1/156 SEPARATION
Br. No. 44-218 · P.M. 91.0

919+87.49 Rt. Trans. = 54+73.35

887+20.99 = 02+40.5

Alisal Slough

Tembladero Beach Drive UC
Br. No. 44-213 1/2 · P.M. 85.5
Approved With Ltr. Nov. 12' 69.

DIVISION OF HIGHWAYS - DISTRICT 05

BETWEEN MARINA AND
MERRITT ST. IN CASTROVILLE

PRELIMINARY TITLE SHEET

05	Mar	1	1"=1300'	35.0/R92.5
----	-----	---	----------	------------

DIST.	COUNTY	ROUTE	POST MILES-TOTAL PROJECT	SHEET NO.	TOTAL SHEETS
05	Mon	1	R850/R222	129	177

A. P. Engstrom
 CIVIL ENGINEER NO. 1114
 DATE APPROVED: December 17, 1973

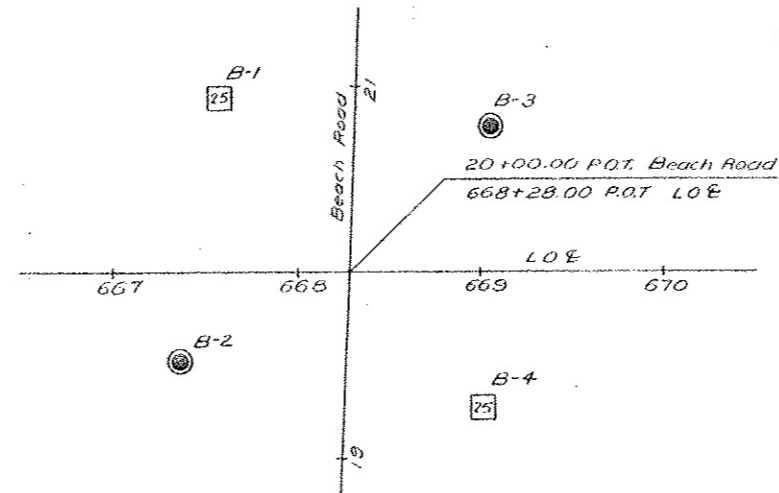

REDUCED PLAN
 USE SCALE BELOW

3 INCHES ON ORIGINAL PLAN

B.M. # M-4A
 1" I.P. at edge of A.C.
 Approx. 89' Lt. "L.O.E." 668+47±
 Elev. 29.67

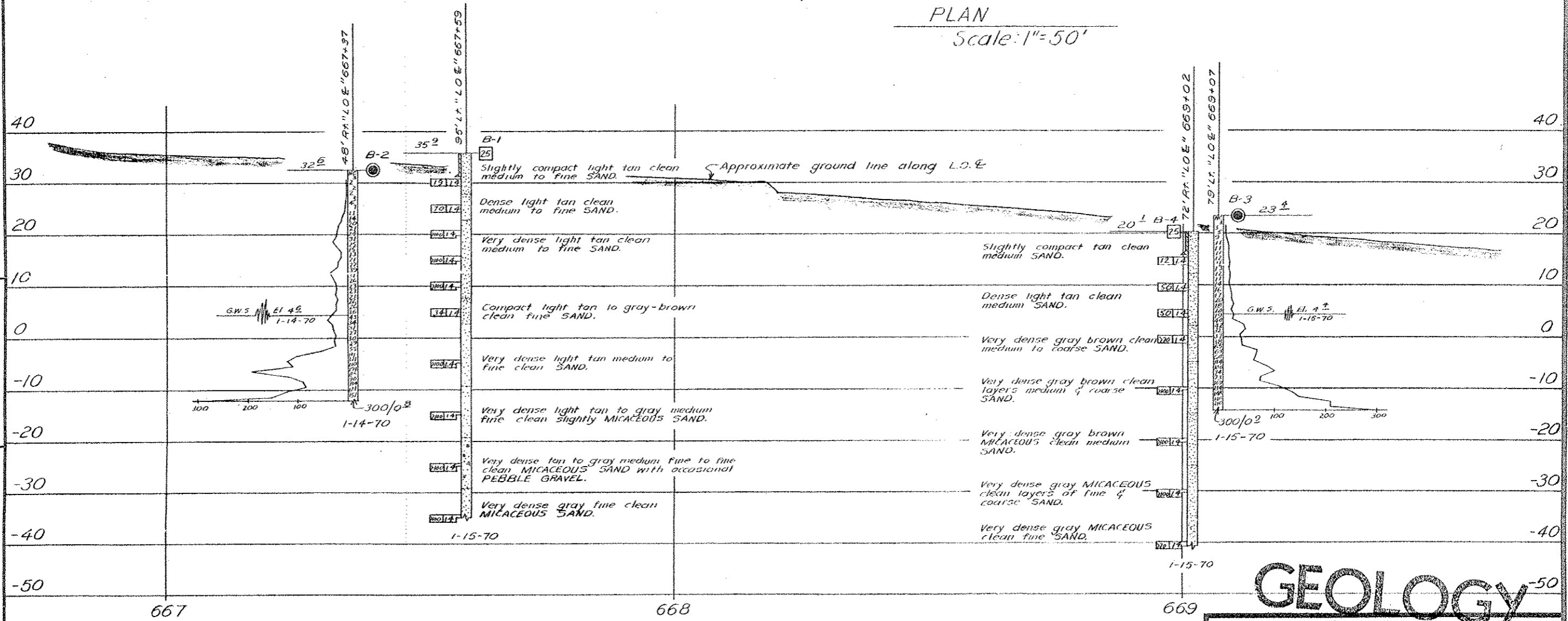

LEGEND OF EARTH MATERIALS

CLASSIFICATION OF MATERIAL BASED ON STANDARD GRADE SIZE LIMITS

CLASSIFICATION OF MATERIAL BASED ON STANDARD GRADE SIZE LIMITS

CLASSIFICATION OF MATERIAL BASED ON STANDARD GRADE SIZE LIMITS

CLASSIFICATION OF MATERIAL BASED ON STANDARD GRADE SIZE LIMITS

LEGEND OF EARTH MATERIALS

CLASSIFICATION OF MATERIAL BASED ON STANDARD GRADE SIZE LIMITS

CLASSIFICATION OF MATERIAL BASED ON STANDARD GRADE SIZE LIMITS

CLASSIFICATION OF MATERIAL BASED ON STANDARD GRADE SIZE LIMITS

CLASSIFICATION OF MATERIAL BASED ON STANDARD GRADE SIZE LIMITS

LEGEND OF EARTH MATERIALS

CLASSIFICATION OF MATERIAL BASED ON STANDARD GRADE SIZE LIMITS

CLASSIFICATION OF MATERIAL BASED ON STANDARD GRADE SIZE LIMITS

CLASSIFICATION OF MATERIAL BASED ON STANDARD GRADE SIZE LIMITS

CLASSIFICATION OF MATERIAL BASED ON STANDARD GRADE SIZE LIMITS

NOTE: Classification of earth material as shown on this sheet is based upon field inspection and is not to be construed to imply mechanical analysis.

FIELD STUDY: W.A. Williams 1-70
 DRAWN: W.S. Schmitt 1-29-70
 CHECKED: T.E. Bimberg 2-27-70
 Approved: [Signature]

129
 BRIDGE DEPARTMENT
 ENGINEERING GEOLOGY SECTION

GEOLOGY

STATE OF CALIFORNIA
 DEPARTMENT OF TRANSPORTATION

RESERVATION ROAD UNDERCROSSING

LOG OF TEST BORINGS

BRIDGE NO. 44-213 R/L	POST MILE 86.5	DRAWING NO.	SHEET 0	OF 6
-----------------------	----------------	-------------	---------	------

WO 022011
 CU 05201

Discard prints bearing earlier revision dates

REVISION DATES (PRELIMINARY STAGE ONLY)

129/10/73				
-----------	--	--	--	--

D & M 1999¹

¹ Please See Figure 5 for full Citation

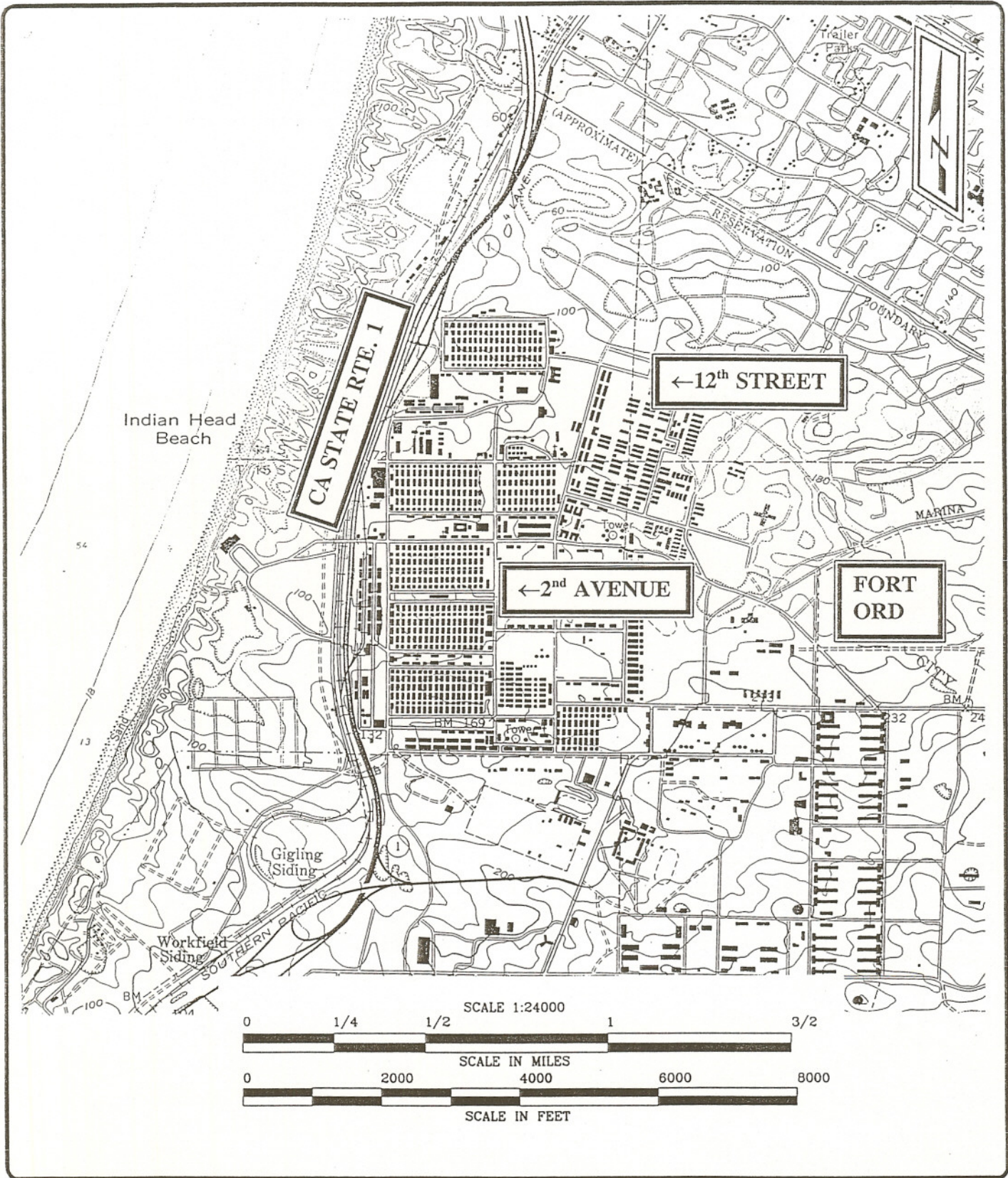

NOVEMBER 1999
 D&M CONSULTING ENGINEERS
 A URS CORPORATION COMPANY

SITE LOCATION MAP
 12th STREET GATEWAY / 2nd AVENUE REALIGNMENTS
 FORT ORD, CALIFORNIA

FIGURE
 1
 PROJECT
 201148

LOG OF TEST BORING						No. B-1							
PROJECT: 12th Street Gateway / 2nd Ave. Realignment			DATE: 7/13/99		LOGGED BY: JS								
DRILL RIG: Truck Mounted Solid Flight Auger			HOLE DIA.: 4.5"										
SAMPLER: T = SPT Sampler; M = Mod. Cal.			GROUND WATER DEPTH: Not Encountered					HOLE ELEVATION: -					
Description	Soil Type	Depth	Sample	Blows per foot	Pocket Pen (tsf)	% Passing #200	Liquid Limit	Water Content	Plastic Limit	Dry Density (pcf)	Failure Strain (pcf)	Unconfined Shear Strength (psf)	
SAND; medium to light brown, moist, loose; poorly graded medium dense	SP	1											
		2	1-1										
		3	M		11								
		4	1-2										
		5	T		14								
		6											
		7	1-3										
		8	M		29								
		9											
		10											
		Boring terminated at 11 1/2 feet.		11	1-4								
12	T				15								
13													
14													
15													
16													
17													
18													
19													
20													
21													
22													
23													
24													
25													
26													

LOG OF TEST BORING

No. B-2

PROJECT: 12th Street Gateway / 2nd Ave. Realignment

DATE: 7/13/99

LOGGED BY: JS

DRILL RIG: Truck Mounted Solid Flight Auger

HOLE DIA.: 4.5"

SAMPLER: T = SPT Sampler; M = Mod. Cal.

GROUND WATER DEPTH: Not Encountered

HOLE ELEVATION: --

Description	Soil Type	Depth	Sample	Blows per foot	Pocket Pen (tsf)	% Passing #200	Liquid Limit	Water Content	Plastic Limit	Dry Density (pcf)	Failure Strain (pcf)	Unconfined Shear Strength (psf)
SAND; medium brown, damp, loose; fine, some organic material	SP	1		7				3		101		
		2	2-1									
		3	M									
		4	2-2	9								
		5	T									
		6		16								
		7	2-3									
		8	M									
		9										
		10		35								
		11	2-4									
12	T											
Boring terminated at 11 1/2 feet.		13										
		14										
		15										
		16										
		17										
		18										
		19										
		20										
		21										
		22										
		23										
		24										
		25										
		26										

LOG OF TEST BORING

No. B-3

PROJECT: 12th Street Gateway / 2nd Ave. Realignment

DATE: 7/13/99

LOGGED BY: JS

DRILL RIG: Truck Mounted Solid Flight Auger

HOLE DIA.: 4.5"

SAMPLER: T = SPT Sampler; M = Mod. Cal.

GROUND WATER DEPTH: Not Encountered

HOLE ELEVATION: --

Description	Soil Type	Depth	Sample	Blows per foot	Pocket Pen (tsf)	% Passing #200	Liquid Limit	Water Content	Plastic Limit	Dry Density (pcf)	Failure Strain (pcf)	Unconfined Shear Strength (psf)	
SAND; medium to light brown, damp, dense; poorly graded (No recovery from this sample.) medium dense	SP	1											
		2	M	40									
		3	3-1										
		4	M	21									
		5											
		6	3-2										
		7	T	17									
		8											
		9											
		10											
		moist		11	3-3								
Boring terminated at 11 1/2 feet.		12	T	20									
		13											
		14											
		15											
		16											
		17											
		18											
		19											
		20											
		21											
		22											
		23											
		24											
		25											
		26											

LOG OF TEST BORING							No. B-4						
PROJECT: 12th Street Gateway / 2nd Ave. Realignment				DATE: 7/13/99		LOGGED BY: JS							
DRILL RIG: Truck Mounted Solid Flight Auger				HOLE DIA.: 4.5"									
SAMPLER: T = SPT Sampler; M = Mod. Cal.													
GROUND WATER DEPTH: Not Encountered				HOLE ELEVATION: --									
Description	Soil Type	Depth	Sample	Blows per foot	Pocket Pen (tsf)	% Passing #200	Liquid Limit	Water Content	Plastic Limit	Dry Density (pcf)	Failure Strain (pcf)	Unconfined Shear Strength (psf)	
SAND; medium to light brown, damp, medium dense; poorly graded moist	SP	1	4-1	13				3		106			
		2	M										
		3	4-2										
		4	T	14									
		5		28									
		6	4-3										
		7	M										
		8		26									
		9											
		10											
		11	4-4										
12	T												
Boring terminated at 11 1/2 feet.		13											
		14											
		15											
		16											
		17											
		18											
		19											
		20											
		21											
		22											
		23											
		24											
		25											
		26											

LOG OF TEST BORING

No. B-5

PROJECT: 12th Street Gateway / 2nd Ave. Realignment

DATE: 7/13/99

LOGGED BY: JS

DRILL RIG: Truck Mounted Solid Flight Auger

HOLE DIA.: 4.5"

SAMPLER: T = SPT Sampler; M = Mod. Cal.

GROUND WATER DEPTH: Not Encountered

HOLE ELEVATION: --

Description	Soil Type	Depth	Sample	Blows per foot	Pocket Pen (tsf)	% Passing #200	Liquid Limit	Water Content	Plastic Limit	Dry Density (pcf)	Failure Strain (pcf)	Unconfined Shear Strength (psf)	
SAND; dark brown, damp, medium dense; fine, some organics light brown darker layer (thin)	SP	1											
		2	5-1										
		3	M		18				3		104		
		4	5-2										
		5	T		11								
		6											
		7	5-3										
		8	M		30				3		105		
		9											
		10											
		11	5-4										
Boring terminated at 11 1/2 feet.		12	T	32									
		13											
		14											
		15											
		16											
		17											
		18											
		19											
		20											
		21											
		22											
		23											
		24											
		25											
		26											

LOG OF TEST BORING							No. B-6					
PROJECT: 12th Street Gateway / 2nd Ave. Realignment				DATE: 7/13/99		LOGGED BY: JS						
DRILL RIG: Truck Mounted Solid Flight Auger				HOLE DIA.: 4.5"								
SAMPLER: T = SPT Sampler; M = Mod. Cal.				GROUND WATER DEPTH: Not Encountered					HOLE ELEVATION: --			
Description	Soil Type	Depth	Sample	Blows per foot	Pocket Pen (tsf)	% Passing #200	Liquid Limit	Water Content	Plastic Limit	Dry Density (pcf)	Failure Strain (pcf)	Unconfined Shear Strength (psf)
SAND; medium to light brown, damp, medium dense; fine, poorly graded loose, coarser grains medium dense moist	SP	1		19								
		2	6-1									
		3	M									
		4	6-2	9								
		5										
		6	T	14								
		7	6-3									
		8	M									
		9										
		10										
		11	6-4	20								
12	T											
Boring terminated at 11 1/2 feet.												
		13										
		14										
		15										
		16										
		17										
		18										
		19										
		20										
		21										
		22										
		23										
		24										
		25										
		26										

LOG OF TEST BORING

No. B-7

PROJECT: 12th Street Gateway / 2nd Ave. Realignment

DATE: 8/25/99

LOGGED BY: JS

DRILL RIG: Truck Mounted Solid Flight Auger

HOLE DIA.: 4.5"

SAMPLER: T = SPT Sampler; M = Mod. Cal.

GROUND WATER DEPTH: Not Encountered

HOLE ELEVATION: --

Description	Soil Type	Depth	Sample	Blows per foot	Pocket Pen (tsf)	% Passing #200	Liquid Limit	Water Content	Plastic Limit	Dry Density (pcf)	Failure Strain (pcf)	Unconfined Shear Strength (psf)		
SAND; med. to dark brown, damp, medium dense; poorly graded, some gravel	SP	1												
		2	7-1											
		3	M	13										
		4	7-2											
		5	T	15										
		6												
		7	7-3											
		8	M	25										
		9												
		10												
		11	7-4											
		12	T	26										
		13												
		14												
		15												
		16	7-5											
17	T	40												
Boring terminated at 16 1/2 feet.														
		18												
		19												
		20												
		21												
		22												
		23												
		24												
		25												
		26												

LOG OF TEST BORING

No. B-8

PROJECT: 12th Street Gateway / 2nd Ave. Realignment

DATE: 8/25/99

LOGGED BY: JS

DRILL RIG: Truck Mounted Solid Flight Auger

HOLE DIA.: 4.5"

SAMPLER: T = SPT Sampler; M = Mod. Cal.

GROUND WATER DEPTH: Not Encountered

HOLE ELEVATION: --

Description	Soil Type	Depth	Sample	Blows per foot	Pocket Pen (tsf)	% Passing #200	Liquid Limit	Water Content	Plastic Limit	Dry Density (pcf)	Failure Strain (pcf)	Unconfined Shear Strength (psf)
SAND; dark brown, damp, medium dense; poorly graded moist very dense	SP	1										
		2	8-1									
		3	M	18								
		4	8-2									
		5	T	15								
		6										
		7	8-3									
		8	M	23								
		9										
		10										
		11	8-4									
		12	T	28								
		13										
		14										
		15										
		16	8-5									
17	T	58										
Boring terminated at 16 1/2 feet.												
		18										
		19										
		20										
		21										
		22										
		23										
		24										
		25										
		26										

LOG OF TEST BORING

No. B-9

PROJECT: 12th Street Gateway / 2nd Ave. Realignment

DATE: 8/25/99

LOGGED BY: JS

DRILL RIG: Truck Mounted Solid Flight Auger

HOLE DIA.: 4.5"

SAMPLER: T = SPT Sampler; M = Mod. Cal.

GROUND WATER DEPTH: Not Encountered

HOLE ELEVATION: --

Description	Soil Type	Depth	Sample	Blows per foot	Pocket Pen (tsf)	% Passing #200	Liquid Limit	Water Content	Plastic Limit	Dry Density (pcf)	Failure Strain (pcf)	Unconfined Shear Strength (psf)
SAND; dark brown, moist, medium dense poorly graded dark brown light brown	SP	1		27								
		2	9-1 M									
		3	9-2 T	6								
		4										
		5		10								
		6	9-3 M									
		7										
		8		17								
		9										
		10										
		11	9-4 T									
		12		30								
		13										
		14										
		15										
		16	9-5 T									
Boring terminated at 16 1/2 feet.		17										
		18										
		19										
		20										
		21										
		22										
		23										
		24										
		25										
		26										

LOG OF TEST BORING

No. B-10

PROJECT: 12th Street Gateway / 2nd Ave. Realignment

DATE: 8/25/99

LOGGED BY: JS

DRILL RIG: Truck Mounted Solid Flight Auger

HOLE DIA.: 4.5"

SAMPLER: T = SPT Sampler; M = Mod. Cal.

GROUND WATER DEPTH: Not Encountered

HOLE ELEVATION: --

Description	Soil Type	Depth	Sample	Blows per foot	Pocket Pen (tsf)	% Passing #200	Liquid Limit	Water Content	Plastic Limit	Dry Density (pcf)	Failure Strain (pcf)	Unconfined Shear Strength (psf)
SAND; light brown, dry, loose; poorly graded MACADAM PAVEMENT; some gravel	SP	1	10-1	64								
		2	M									
SAND; dark to medium brown, damp, medium dense	SP	3	10-2	19								
		4	T									
light brown		5		15								
		6	10-3									
		7	T									
		8										
		9										
		10										
		11	10-4									
Boring terminated at 11 1/2 feet.		12	T	18								
		13										
		14										
		15										
		16										
		17										
		18										
		19										
		20										
		21										
		22										
		23										
		24										
		25										
		26										

RESULTS OF PAVEMENT CORING

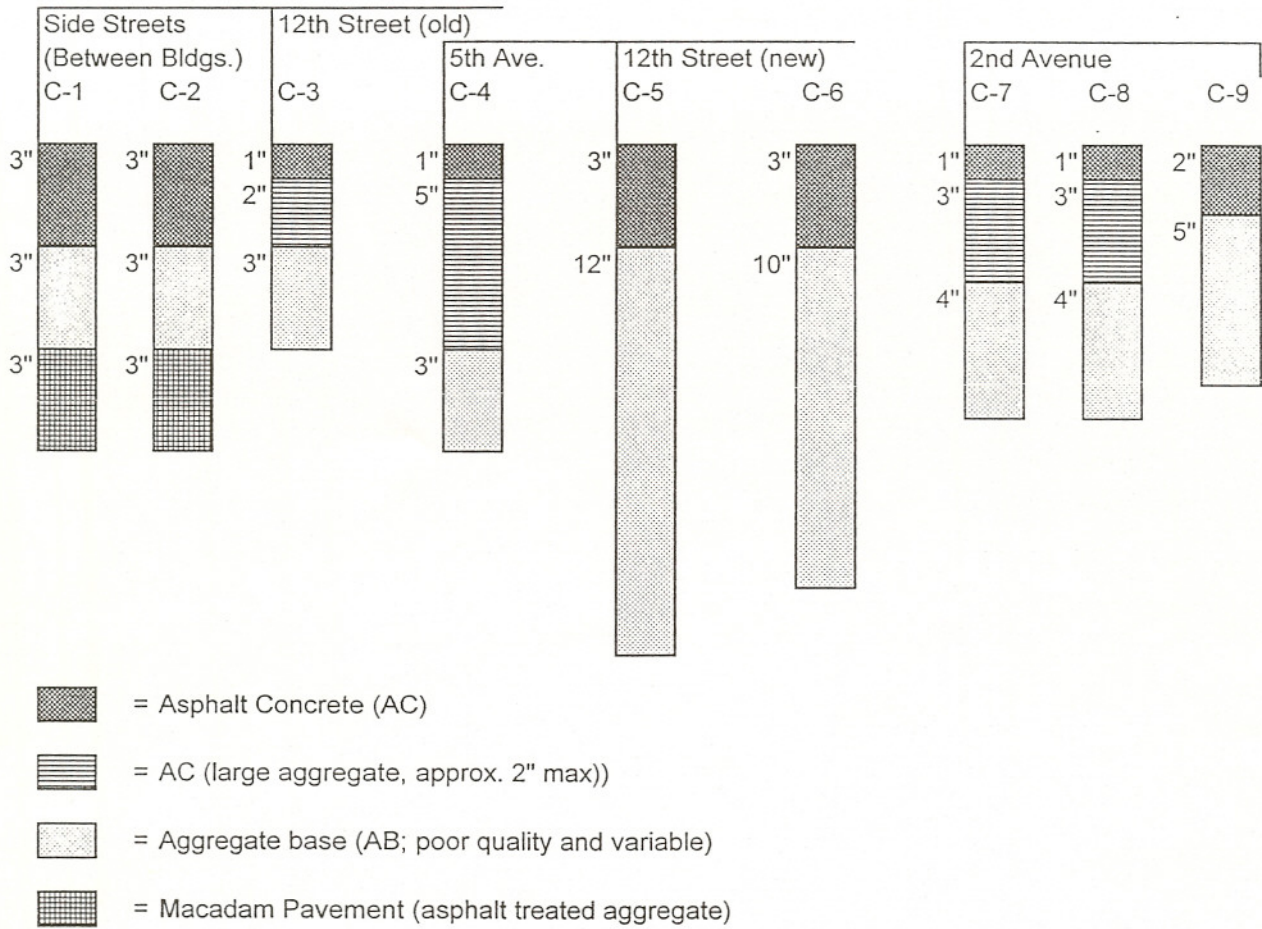

NOVEMBER 1999
 D&M CONSULTING ENGINEERS
 A URS CORPORATION COMPANY

EXISTING PAVEMENT SECTIONS
 12th STREET GATEWAY / 2nd AVENUE REALIGNMENTS
 FORT ORD, CALIFORNIA

FIGURE
 2
 PROJECT
 201148

R-VALUE REPORT

Terratech, Inc.

ASTM D2844

(408) 372-3716

Project: 12th Street Gateway

Date: 7/29/99

Client: Bestor Engineers

Project #: 201148

Lab #: L5054

Sample #: R-1 (Bulk)

Sample Date: 7/21/99

Material Description: SAND; dark brown

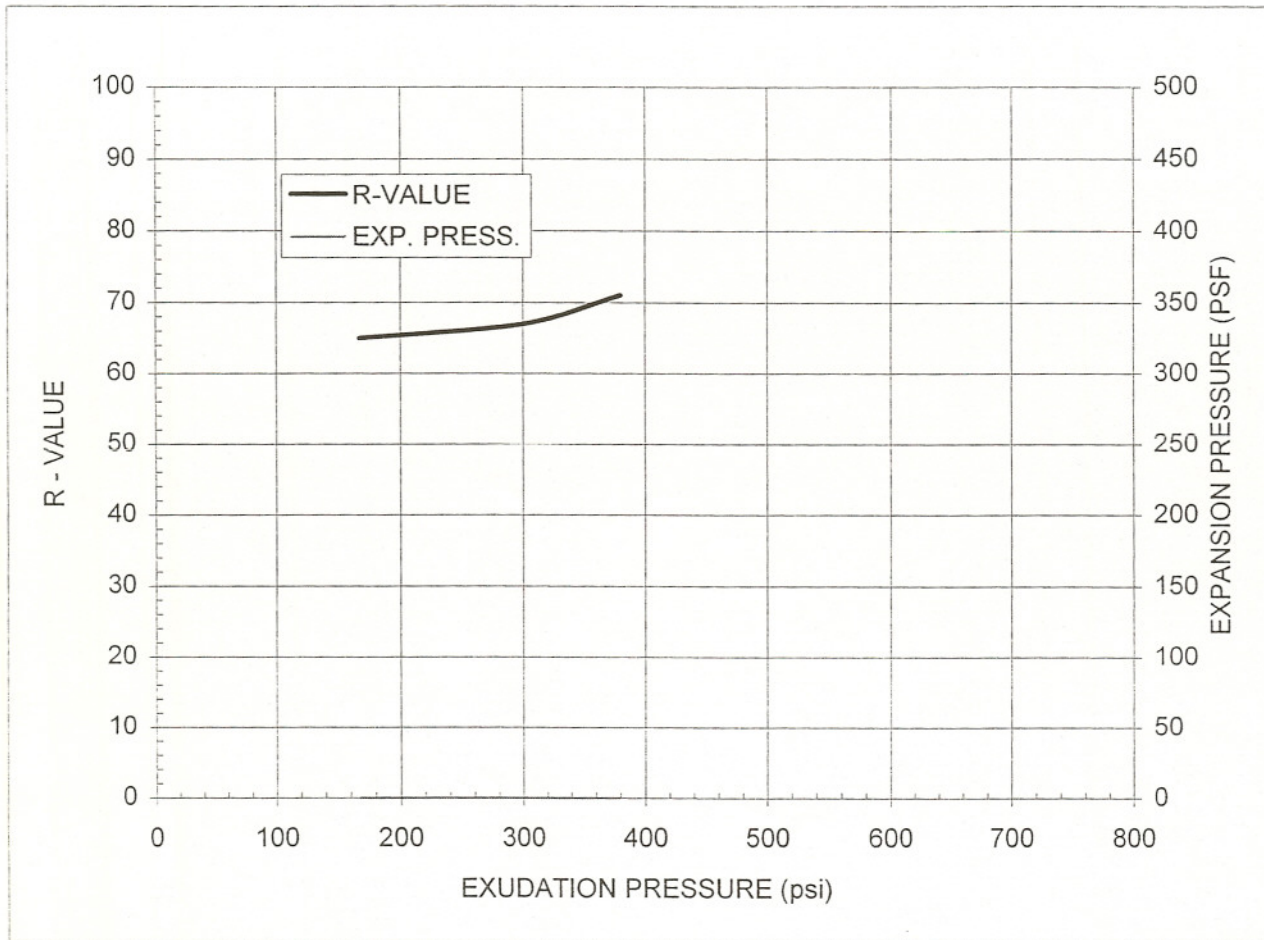

Specimen No.	A	B	C	
Exudation Pressure, psi	167	300	380	
Expansion Pressure, psf	0	0	0	
R-Value	65	67	71	
Moisture Content at Test, %	14.8	13.9	11.4	
Dry Density at Test, pcf	108.1	108.4	109.9	
R-Value @ 300 psi Exudation Pressure =		67	Expansion Pressure @300 psi Exudat'n, psf =	
			0	

Comments:

Report By: Gary A. Bomberger, Laboratory Manager

R-VALUE REPORT

Terratech, Inc.

ASTM D2844

(408) 372-3716

Project: 12th Street Gateway

Date: 7/29/99

Client: Bestor Engineers

Project #: 201148

Lab #: L5054

Sample #: R-2 (Bulk)

Sample Date: 7/21/99

Material Description: SAND; tan

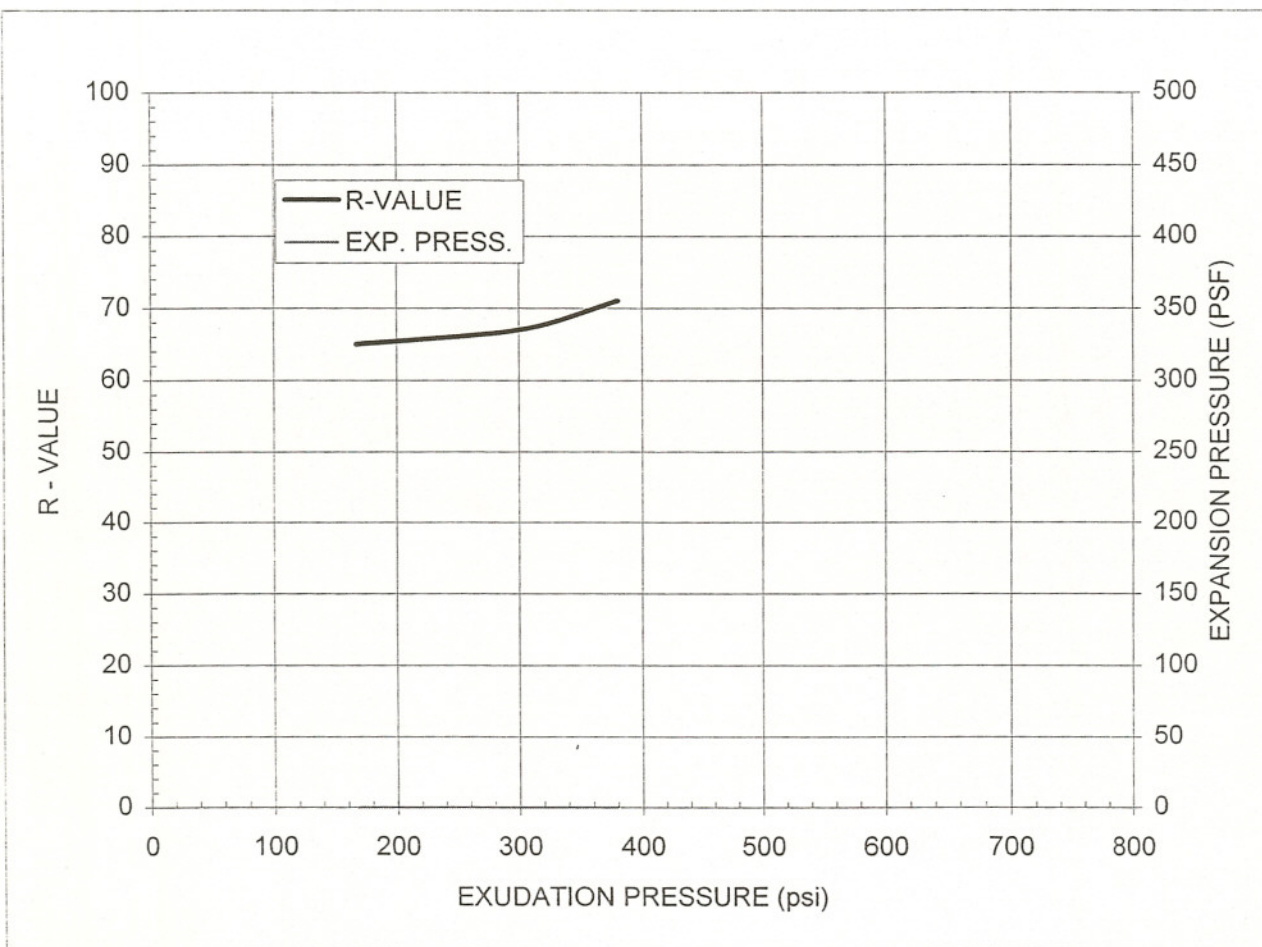

Specimen No.	A	B	C
Exudation Pressure, psi	280	380	440
Expansion Pressure, psf	0	0	0
R-Value	59	63	68
Moisture Content at Test, %	16.3	14.2	12.5
Dry Density at Test, pcf	103.6	104.6	110.2

R-Value @ 300 psi Exudation Pressure = **60**

Expansion Pressure @300 psi Exudat'n, psf = **0**

Comments:

Report By: Gary A. Bomberger, Laboratory Manager

R-VALUE REPORT

Terratech, Inc.

ASTM D2844

(408) 372-3716

Project: 12th Street Gateway

Date: 7/29/99

Client: Bestor Engineers

Project #: 201148

Lab #: L5054

Sample #: R-3 (Bulk)

Sample Date: 7/21/99

Material Description: SAND; tan

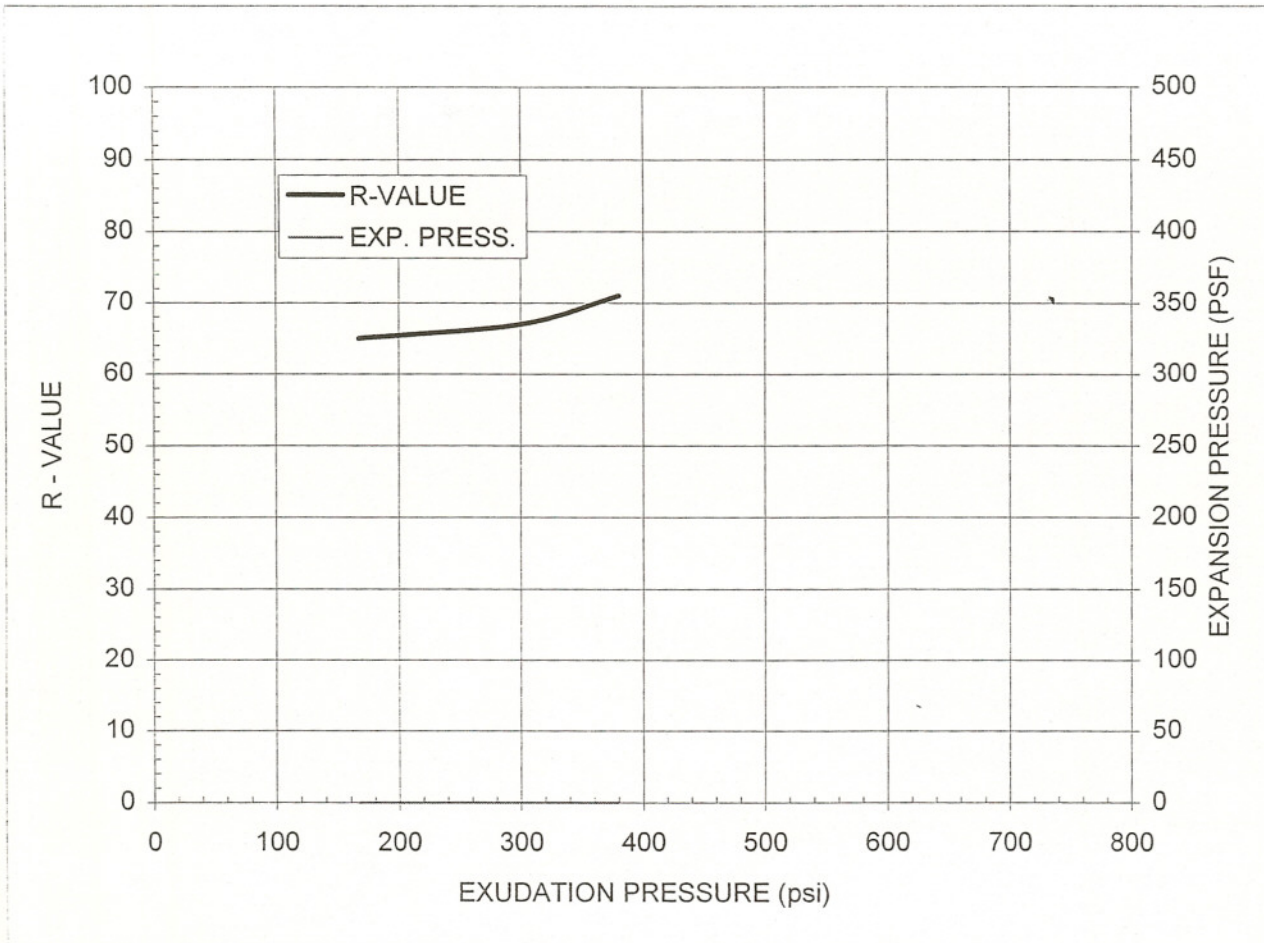

Specimen No.	A	B	C
Exudation Pressure, psi	220	300	600
Expansion Pressure, psf	0	0	0
R-Value	37	45	57
Moisture Content at Test, %	15.2	14.4	1.8
Dry Density at Test, pcf	102.6	105.4	105.9

R-Value @ 300 psi Exudation Pressure = **40**

Expansion Pressure @300 psi Exudat'n, psf = **0**

Comments:

Report By: Gary A. Bomberger, Laboratory Manager

DCM Engineering 2006¹

¹ Please see Figure 5 for full citation.

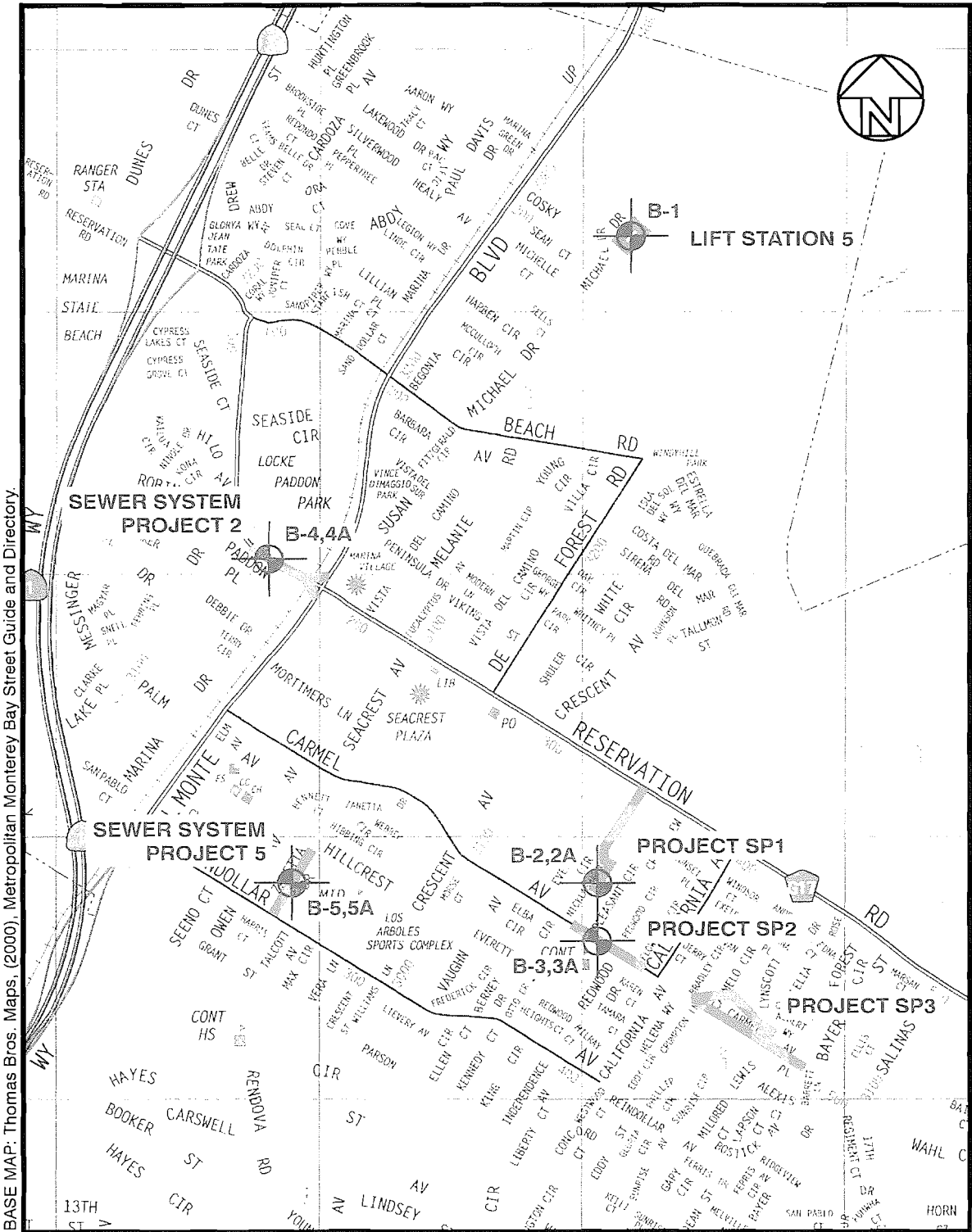

BASE MAP: Thomas Bros. Maps, (2000), Metropolitan Monterey Bay Street Guide and Directory.

LEGEND:

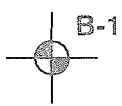

- Approximate location of project geotechnical borings



- Approximate project alignments/site locations

DCM Engineering

WINZLER & KELLY
 Marina Coast Water District
 2005 Marina Sewer Improvement Projects
 Marina, California

PLATE NO.

























2

FILE NO. J-4962-1

APRIL 2006

BORING LOCATION MAP

KEY TO BORING LOG

<table border="0" style="width: 100%;"> <tr> <td style="width: 20px; text-align: center;"></td> <td>Shelby tube sample</td> </tr> <tr> <td style="width: 20px; text-align: center;"></td> <td>Grab sample</td> </tr> <tr> <td style="width: 20px; text-align: center;"></td> <td>1.4" I.D./2" O.D. Standard Penetration Test (ASTM D1586) sampler (SPT)</td> </tr> <tr> <td style="width: 20px; text-align: center;"></td> <td>2.5" I.D./3" O.D. Modified California sampler (MCS) with brass liners</td> </tr> <tr> <td style="width: 20px; text-align: center;"></td> <td>2" I.D./2.5" O.D. Split Spoon sampler (SSS)</td> </tr> </table>		Shelby tube sample		Grab sample		1.4" I.D./2" O.D. Standard Penetration Test (ASTM D1586) sampler (SPT)		2.5" I.D./3" O.D. Modified California sampler (MCS) with brass liners		2" I.D./2.5" O.D. Split Spoon sampler (SSS)	<table border="0" style="width: 100%;"> <tr> <td style="width: 20px; text-align: center;">NSR</td> <td>No sample recovery</td> </tr> <tr> <td style="width: 20px; text-align: center;">PP</td> <td>Pocket Penetrometer (tsf = tons per square foot)</td> </tr> <tr> <td style="width: 20px; text-align: center;"></td> <td>Groundwater level observed in boring at end of drilling unless noted otherwise. Not to be interpreted as the equilibrium groundwater level.</td> </tr> <tr> <td style="width: 20px; text-align: center;"></td> <td>Groundwater seepage encountered during drilling</td> </tr> <tr> <td style="width: 20px; text-align: center;"></td> <td>Planned pipeline I.D. (projected to boring)</td> </tr> </table>	NSR	No sample recovery	PP	Pocket Penetrometer (tsf = tons per square foot)		Groundwater level observed in boring at end of drilling unless noted otherwise. Not to be interpreted as the equilibrium groundwater level.		Groundwater seepage encountered during drilling		Planned pipeline I.D. (projected to boring)
	Shelby tube sample																				
	Grab sample																				
	1.4" I.D./2" O.D. Standard Penetration Test (ASTM D1586) sampler (SPT)																				
	2.5" I.D./3" O.D. Modified California sampler (MCS) with brass liners																				
	2" I.D./2.5" O.D. Split Spoon sampler (SSS)																				
NSR	No sample recovery																				
PP	Pocket Penetrometer (tsf = tons per square foot)																				
	Groundwater level observed in boring at end of drilling unless noted otherwise. Not to be interpreted as the equilibrium groundwater level.																				
	Groundwater seepage encountered during drilling																				
	Planned pipeline I.D. (projected to boring)																				

RELATIVE DENSITY		CONSISTENCY		
SANDS AND GRAVELS	SPT, N	SILTS AND CLAYS	SPT, N	UNCONFINED COMPRESSIVE STRENGTH, tsf
VERY LOOSE	0-4	VERY SOFT	0-2	0-0.25
LOOSE	4-10	SOFT	2-4	0.25-0.50
MEDIUM DENSE	10-30	MEDIUM STIFF	4-8	0.50-1.00
DENSE	30-50	STIFF	8-15	1.00-2.00
VERY DENSE	50+	VERY STIFF	15-30	2.00-4.00
		HARD	30+	>4.00

Reference: Terzaghi, K. and Peck, R., SOIL MECHANICS IN ENGINEERING PRACTICE, 2nd ed., John Wiley and Sons, New York, 1967. Page 341 Table 45.1 and pp. 347 Table 45.2.

MOISTURE CONDITION	
DESCRIPTION	CRITERIA
DRY	Absence of moisture, dusty, dry to the touch
MOIST	Damp but no visible water
WET	Visible free water, usually soil is below water table

Reference: ASTM D2488, Table 3 - Criteria for Describing Moisture Condition

CONSTITUENT DESCRIPTIONS	
DESCRIPTION	CRITERIA
TRACE	less than 5%
FEW	5% to 10%
LITTLE	15% to 25%
SOME	30% to 45%
MOSTLY	50% to 100%

Reference: ASTM D2488, Note 15

NOTES:

1. Lines separating strata in the logs represent approximate boundaries only and are dashed where strata change depth is less certain and queried where strata change depth is not known. Actual strata change may be gradual. No warranty is provided as to the continuity of strata between borings. Logs represent the subsurface section observed at the boring location on the date of drilling only.
2. Penetration Resistance (blows/ft.) are the last 12" of an 18" drive or the middle 12" of a 24" drive using a 140-pound hammer falling 30 inches per blow unless noted otherwise. The Penetration Resistance values noted on the logs are actual blows per foot of penetration for the respective sampler type (i.e., MCS and SSS sampler Penetration Resistance has not been correlated to an equivalent SPT sampler "N" value).
3. All borings were made with a truck mounted Mobile B-24 drill rig using 4-inch diameter continuous flight solid stem augers unless noted otherwise.
4. Where noted on the boring logs, slough is defined as material from the bore hole walls which collapses into and partially fills the open bore hole on removal of the solid flight augers for sampling. The presence of slough within the borehole can contaminate the sampled soils or render drive sampling impossible (samplers fill entirely with slough).

DCM Engineering

WINZLER & KELLY
Marina Coast Water District
2005 Marina Sewer Improvement Projects
Marina, California

PLATE NO.

A-1

FILE NO. J-4962-1

APRIL 2006

BORING LOG LEGEND

(1 of 2)

UNIFIED SOIL CLASSIFICATION SYSTEM

CRITERIA FOR ASSIGNING GROUP SYMBOLS AND GROUP NAMES ^A			GROUP SYMBOL	GROUP NAME ^B
COARSE-GRAINED SOILS More than 50% retained on No. 200 sieve	GRAVELS More than 50% of coarse fraction retained on No. 4 sieve	Clean Gravels < 5% fines ^C	$Cu \geq 4$ and $1 \leq Cc \leq 3^E$	GW Well-graded gravel ^F
		Gravels with Fines > 12% fines ^C	$Cu < 4$ and/or $1 > Cc > 3^E$	GP Poorly graded gravel ^F
		Fines classify as ML or MH	GM Silty gravel ^{F,G,H}	
		Fines classify as CL or CH	GC Clayey gravel ^{F,G,H}	
	SANDS 50% or more of coarse fraction passes No. 4 sieve	Clean Sands < 5% fines ^D	$Cu \geq 6$ and $1 \leq Cc \leq 3^E$	SW Well-graded sand ^I
		Sands with Fines > 12% fines ^D	$Cu < 6$ and/or $1 > Cc > 3^E$	SP Poorly graded sand ^I
		Fines classify as ML or MH	SM Silty sand ^{G,H,I}	
		Fines classify as CL or CH	SC Clayey sand ^{G,H,I}	
FINE-GRAINED SOILS 50% or more passes the No. 200 sieve	SILTS AND CLAYS Liquid limit ≤ 50	Inorganic	$PI > 7$ plots on or above "A" line ^J	CL Lean clay ^{K,L,M}
		Organic	$PI < 4$ plots below "A" line ^J	ML Silt ^{K,L,M}
		Liquid limit-oven dried Liquid limit-not dried < 0.75	OL Organic Clay ^{K,L,M,N} Organic Silt ^{K,L,M,O}	
		PI plots on or above "A" line	CH Fat clay ^{K,L,M}	
	SILTS AND CLAYS Liquid limit > 50	Inorganic	PI plots below "A" line	MH Elastic silt ^{K,L,M}
		Organic	Liquid limit-oven dried Liquid limit-not dried < 0.75	OH Organic Clay ^{K,L,M,P} Organic Silt ^{K,L,M,Q}
		Primarily organic matter, dark color and organic odor		PT Peat
		Primarily organic matter, dark color and organic odor		PT Peat

NOTES:

- A Based on the material passing the 3-in. (75mm) sieve.
- B If field sample contained cobbles or boulders, or both, add "with cobbles or boulders, or both" to group name.
- C Gravels with 5% to 12% fines require dual symbols:
 GW-GM well-graded gravel with silt
 GW-GC well-graded gravel with clay
 GP-GM poorly graded gravel with silt
 GP-GC poorly graded gravel with clay
- D Sands with 5% to 12% fines require dual symbols:
 SW-SM well-graded sand with silt
 SW-SC well-graded sand with clay
 SP-SM poorly graded sand with silt
 SP-SC poorly graded sand with clay
- E $Cu = \frac{D_{60}}{D_{10}}$ $Cc = \frac{(D_{30})^2}{D_{10} \times D_{60}}$
- F If soil contains $\geq 15\%$ sand, add "with sand" to group name.
- G If fines classify as CL-ML, use dual symbol GC-GM, or SC-SM.
- H If fines are organic, add "with organic fines" to group name.
- I If soil contains $\geq 15\%$ gravel, add "with gravel" to group name.
- J If Atterberg limits plot in hatched area, soil is a CL-ML (silty clay).
- K If soil contains 15% to 29% plus No. 200, add "with sand" or "with gravel", whichever is predominant.
- L If soil contains $\geq 30\%$ plus No. 200, predominantly sand, add "sandy" to group name.
- M If soil contains $\geq 30\%$ plus No. 200, predominantly gravel, add "gravelly" to group name.
- N $PI \geq 4$ and plots on or above "A" line.
- O $PI < 4$ or plots below "A" line.
- P PI plots on or above "A" line.
- Q PI plots below "A" line.

DCM Engineering

WINZLER & KELLY

Marina Coast Water District
 2005 Marina Sewer Improvement Projects
 Marina, California

PLATE NO.

A-1

(2 of 2)

TUNNELMAN'S GROUND CLASSIFICATION FOR SOILS

Classification		Behavior	Typical Soil Types
FIRM		Heading can be advanced without initial support and final lining can be constructed before ground starts to move.	Loess above water table; hard clay, marl, cemented sand and gravel when not highly overstressed.
RAVELING	Slow Raveling	Chunks or flakes of material begin to drop out of the arch or walls sometime after the ground has been exposed due to loosening or to overstress and "brittle" fracture (ground separates or breaks along distinct surfaces, opposed to squeezing ground). In fast raveling ground, the process starts within a few minutes, otherwise the ground is slow raveling.	Residual soils or sand with small amounts of binder may be fast raveling below the water table, slow raveling above. Stiff fissured clays may be slow or fast raveling depending upon degree of overstress.
	Fast Raveling		
SQUEEZING		Ground squeezes or extrudes plastically into tunnel, without visible fracturing or loss of continuity, and without perceptible increase in water content. Ductile, plastic yield and flow due to overstress.	Ground with low frictional strength. Rate of squeeze depends on degree of overstress. Occurs at shallow to medium depth in clay of very soft to medium consistency. Stiff to hard clay under high cover may move in combination of raveling at excavation surface and squeezing at depth behind surface.
RUNNING	Cohesive, running	Granular materials without cohesion are unstable at a slope greater than their angle of repose ($\pm 30-35^\circ$). When exposed at steeper slopes, they run like granulated sugar or dune sand until the slope flattens to the angle of repose.	Clean, dry granular materials. Apparent cohesion in moist sand, or weak cementation in any granular soil may allow the material to stand for brief period of raveling before it breaks down and runs. Such behavior is cohesive-running.
	Running		
FLOWING		A mixture of soil and water flows into the tunnel like a viscous fluid. The material can enter the tunnel from the invert as well as from the face, crown, and walls, and can flow for great distances, completely filling the tunnel in some cases.	Below the water table in silt, sand, or gravel without enough clay content to give significant cohesion and plasticity. May also occur in highly sensitive clay when such material is disturbed.
SWELLING		Ground absorbs water, increases in volume, and expands slowly into the tunnel.	Highly preconsolidated clay with plasticity index in excess of about 30, generally containing significant percentages of montmorillonite.

REFERENCE: Heuer, R.E., 1974, Important ground parameters in soft ground tunneling, Subsurface exploration for underground excavation and heavy construction, New England College, Henniker, New Hampshire, American Society of Civil Engineers, New York, P. 41-55.

DCM Engineering

WINZLER & KELLY
 Marina Coast Water District
 2005 Marina Sewer Improvement Projects
 Marina, California
**TUNNELMAN'S GROUND
 CLASSIFICATION**

PLATE NO.

A-2

FILE NO. J-4962-1

APRIL 2006

DEPTH feet	SAMPLE NO.	TYPE	PENETRATION RESISTANCE blows/ft.	GROUNDWATER	LOG OF BORING B-1		% MOISTURE	DRY DENSITY lbs./ft. ³	LIQUID LIMIT	PLASTICITY INDEX	GRAIN SIZE			UNCONFINED COMPRESSIVE STRENGTH kips/ft. ²	DIRECT SHEAR	
					LOCATION: South and west of existing Lift Station No. 5 (outside fence; approximately 4' west of fence and 4' north of gate).						DESCRIPTION ①					Cohesion p.s.f.
5	1		9			POORLY GRADED SAND WITH CLAY (SP-SC) - brown - predominantly fine-grained sand - trace ¼ to ½ inch gravel near surface - trace organics (roots) - very little cohesion - loose - dry	2	91			0	92	8			
	2		10				2	101			CORROSION TEST See Plate C-6			60	32°	
10	3		9			POORLY GRADED SAND (SP) - light olive brown to yellowish brown - predominantly fine-grained sand - very little cohesion - loose to medium dense - dry to moist										
	4		25				2	102								
15	5		18								0	96	4			
	6		6			ORGANIC CLAY (OH) - pale brown and olive - yellow mottled with light - olive brown streaks - high plasticity - medium stiff - moist to wet	134	36	199	153	LL RATIO O.D. N.D. = 0.35			1.92		
20	7		33			POORLY GRADED SAND WITH CLAY (SP-SC) - olive brown - predominantly fine-grained sand - high plasticity clay - dense - wet										
	8		50 (6")		②		13	121			0	88	12	FINES 6% Silt 6% Clay		
25	9		46													
					BOTTOM OF BORING AT 25.5 FEET											

REMARKS: ① Boring drilled on October 20, 2005. See Plate A-1 in Appendix A for definitions of terms.
 ② Groundwater level shown on log was recorded during drilling. At the end of drilling, the borehole collapsed to a depth of 22 feet with no free groundwater on top of collapsed portion.

DCM Engineering

WINZLER & KELLY
 Marina Coast Water District
 2005 Marina Sewer Improvement Projects
 Marina, California
LOG OF BORING B-1

PLATE NO.

B-1

FILE NO. J-4962-1

APRIL 2006

DEPTH feet	SAMPLE NO.	TYPE	PENETRATION RESISTANCE blows/ft.	GROUNDWATER	LOG OF BORING B-2 LOCATION: In front of #3102 Nicklas Lane (see Plate 2).		% MOISTURE	DRY DENSITY lbs./ft. ³	LIQUID LIMIT	PLASTICITY INDEX	GRAIN SIZE			UNCONFINED COMPRESSIVE STRENGTH kips/ft. ²	DIRECT SHEAR	
					DESCRIPTION ①						Gravel (> #4 sieve) %	Sand (#4 to #200 sieve) %	Fines (< #200 sieve) %		Cohesion p.s.f.	Internal Friction Angle
				②	POORLY GRADED SAND (SP) - very dark grayish brown - predominantly fine-grained sand - very little cohesion - dry											
1			16		POORLY GRADED SAND (SP) - dark yellowish brown to light olive brown - predominantly fine-grained sand - very little cohesion - medium dense - dry		3	103								
5	2		13									0	99	1		
					POORLY GRADED SAND (SP) - light olive brown - predominantly fine-grained sand - very little cohesion - medium dense - dry											
10	3		21													
					POORLY GRADED SAND (SP) - light olive brown - predominantly fine-grained sand - very little cohesion - medium dense - dry		3	102								
10	4		18									1	97	2		
					POORLY GRADED SAND (SP) - light olive brown - predominantly fine-grained sand - very little cohesion - medium dense - dry											
15	5		31													
					POORLY GRADED SAND (SP) - light olive brown - predominantly fine-grained sand - very little cohesion - medium dense - dry											
15	6		23													
					POORLY GRADED SAND (SP) - light olive brown - predominantly fine-grained sand - very little cohesion - medium dense - dry											
15	7		19													
20	BOTTOM OF BORING AT 19.5 FEET															

REMARKS: ① Boring drilled on October 20, 2005. See Plate A-1 in Appendix A for definitions of terms.
 ② No free groundwater encountered during drilling.
 ③ Projected existing pipeline depth from Winzler & Kelly 50% Submittal Drawings (2006).

DCM Engineering

WINZLER & KELLY
 Marina Coast Water District
 2005 Marina Sewer Improvement Projects
 Marina, California
 LOG OF BORING B-2

PLATE NO.

B-2

FILE NO. J-4962-1

APRIL 2006

DEPTH feet	SAMPLE NO.	TYPE	PENETRATION RESISTANCE blows/ft.	GROUNDWATER	LOG OF BORING B-3		MOISTURE %	DRY DENSITY lbs./ft. ³	LIQUID LIMIT	PLASTICITY INDEX	GRAIN SIZE			UNCONFINED COMPRESSIVE STRENGTH kips/ft. ²	DIRECT SHEAR	
					LOCATION: Carmel Avenue at intersection with Pleasant Circle (see Plate 2).						Gravel % (> #4 sieve)	Sand % (#4 to #200 sieve)	Fines % (< #200 sieve)		Cohesion p.s.f.	Internal Friction Angle
					DESCRIPTION ①											
				②	CARMEL AVENUE - approximately 3 inches asphalt over 10 inches aggregate base											
					POORLY GRADED SAND (SP) - very dark grayish brown - very little cohesion - predominantly fine-grained sand - dry - trace gravel											
5	1		12		POORLY GRADED SAND (SP) - dark yellowish brown - very little cohesion - predominantly fine-grained sand - loose - dry					4	106		0	96	4	
10	2		18		POORLY GRADED SAND (SP) - light olive brown to brownish yellow - predominantly fine-grained sand - very little cohesion - loose, becoming medium dense with depth - dry					3	102		0	99	1	
	3		13													
	4		32							4	101					
15	5		26													
	6		23							3						
20	BOTTOM OF BORING AT 19.5 FEET															
25																

REMARKS: ① Boring drilled on October 20, 2005. See Plate A-1 in Appendix A for definitions of terms.
 ② No free groundwater encountered during drilling.
 ③ Projected existing pipeline depth from Winzler & Kelly 50% Submittal Drawings (2006).

DCM Engineering

WINZLER & KELLY
 Marina Coast Water District
 2005 Marina Sewer Improvement Projects
 Marina, California
 LOG OF BORING B-3

PLATE NO.

B-3

FILE NO. J-4962-1

APRIL 2006

DEPTH feet	SAMPLE NO.	TYPE	PENETRATION RESISTANCE blows/ft.	GROUNDWATER	LOG OF BORING B-3A		% MOISTURE lbs./ft. ³	DRY DENSITY lbs./ft. ³	LIQUID LIMIT	PLASTICITY INDEX	GRAIN SIZE			UNCONFINED COMPRESSIVE STRENGTH kips/ft. ²	DIRECT SHEAR	
					LOCATION: Carmel Avenue at intersection with Pleasant Circle (see Plate 2). Boring is within backfill for existing sanitary sewer.						DESCRIPTION ①		% Gravel (> #4 sieve)		% Sand (#4 to #200 sieve)	% Fines (< #200 sieve)
					②	CARMEL AVENUE - approximately 3 inches asphalt over 10 inches aggregate base										
1		X				FILL - POORLY GRADED SAND										
2			4			- dark brown - very loose - predominantly fine grained sand - dry to moist - very little cohesion	5	96								
5						BOTTOM OF BORING AT 4.5 FEET										
10						<div style="border: 1px solid black; padding: 5px; width: fit-content; margin: auto;"> MOISTURE-DENSITY RELATIONSHIP Using Sample 1 from Boring B-3A Maximum Dry Density = 118 pcf Optimum Moisture = 10% See Plate C-5 </div>										
15																
20																
25																

REMARKS: ① Boring drilled on October 20, 2005. See Plate A-1 in Appendix A for definitions of terms.
 ② No free groundwater encountered during drilling.
 ③ Projected existing pipeline depth from Winzler & Kelly 50% Submittal Drawings (2006).

DCM Engineering

WINZLER & KELLY
 Marina Coast Water District
 2005 Marina Sewer Improvement Projects
 Marina, California
LOG OF BORING B-3A

PLATE NO.

B-3A

FILE NO. J-4962-1

APRIL 2006

DEPTH feet	SAMPLE NO.	TYPE	PENETRATION RESISTANCE blows/ft.	GROUNDWATER	LOG OF BORING B-4A		% MOISTURE	DRY DENSITY lbs./ft. ³	LIQUID LIMIT	PLASTICITY INDEX	GRAIN SIZE			UNCONFINED COMPRESSIVE STRENGTH kips/ft. ²	DIRECT SHEAR	
					LOCATION: Reservation Road, approximately 450 feet west of Del Monte Boulevard (see Plate 2). Boring is within backfill for existing sanitary sewer.	DESCRIPTION ①					% Gravel (> #4 sieve)	% Sand (#4 to #200 sieve)	% Fines (< #200 sieve)		Cohesion p.s.f.	Internal Friction Angle
				②	RESERVATION RD. - approximately 1 inch asphalt over 6 inches aggregate base											
1			15		FILL - POORLY GRADED SAND - brown - fine-grained sand - very little cohesion - medium dense to loose - moist		4	101								
5	2		4								0	96	4			
					BOTTOM OF BORING AT 6 FEET											
10					<div style="border: 1px solid black; padding: 5px; display: inline-block;"> MOISTURE-DENSITY RELATIONSHIP Using drilled cuttings from Boring B-4A Maximum Dry Density = 116 pcf Optimum Moisture = 11% </div>											
15																
20																
25																

REMARKS: ① Boring drilled on March 23, 2006. See Plate A-1 in Appendix A for definitions of terms.
 ② No free groundwater encountered during drilling.
 ③ Projected existing pipeline depth from Winzler & Kelly 50% Submittal Drawings (2006).

DCM Engineering

WINZLER & KELLY
 Marina Coast Water District
 2005 Marina Sewer Improvement Projects
 Marina, California
LOG OF BORING B-4A

PLATE NO.

B-4A

FILE NO. J-4962-1

APRIL 2006

DEPTH feet	SAMPLE NO.	TYPE	PENETRATION RESISTANCE blows/ft.	GROUNDWATER	LOG OF BORING B-5 LOCATION: Zanetta Drive, approximately 340 feet north of Reindollar Avenue (see Plate 2).	% MOISTURE	DRY DENSITY lbs./ft. ³	LIQUID LIMIT	PLASTICITY INDEX	GRAIN SIZE			UNCONFINED COMPRESSIVE STRENGTH kips/ft. ²	DIRECT SHEAR						
										Gravel % (> #4 sieve)	Sand % (#4 to #200 sieve)	Fines % (< #200 sieve)		Cohesion p.s.f.	Internal Friction Angle					
DESCRIPTION ①																				
				②	ZANETTA DRIVE - approximately 2 inch asphalt over 6 inches aggregate base															
1			20		POORLY GRADED SAND (SP) - dark brown and light olive brown marbled - very little cohesion - moist - fine-grained sand	2	102													
5			13			POORLY GRADED SAND (SP) - light olive brown - fine-grained sand - very little cohesion - medium dense - moist														
3			21			4	104			0	99	1								
10			11																	
5			26			2														
15			30																	
7			24			4														
Borehole sloughing below 16' (see table below)																				
BOTTOM OF BORING AT 19.5 FEET																				
SLOUGH DEPTHS ON SAMPLING <table border="1" style="margin: auto;"> <thead> <tr> <th>Sample No.</th> <th>Slough Depth*</th> </tr> </thead> <tbody> <tr> <td>5-7</td> <td>2'</td> </tr> </tbody> </table> <p>*- slough depth measured from intended sample depth</p>						Sample No.	Slough Depth*	5-7	2'											
Sample No.	Slough Depth*																			
5-7	2'																			

REMARKS: ① Boring drilled on March 23, 2006. See Plate A-1 in Appendix A for definitions of terms.
 ② No free groundwater encountered during drilling.
 ③ Projected existing pipeline depth from Winzler & Kelly 50% Submittal Drawings (2006).

DCM Engineering

WINZLER & KELLY
 Marina Coast Water District
 2005 Marina Sewer Improvement Projects
 Marina, California
LOG OF BORING B-5

PLATE NO.

B-5

FILE NO. J-4962-1

APRIL 2006

DEPTH feet	SAMPLE NO.	TYPE	PENETRATION RESISTANCE blows/ft.	GROUNDWATER	LOG OF BORING B-5A		MOISTURE %	DRY DENSITY lbs./ft. ³	LIQUID LIMIT	PLASTICITY INDEX	GRAIN SIZE			UNCONFINED COMPRESSIVE STRENGTH kips/ft. ²	DIRECT SHEAR	
					LOCATION: Zanetta Drive, approximately 340 feet north of Reindollar Avenue (see Plate 2). Boring is within backfill for existing sanitary sewer.	DESCRIPTION ①					Gravel % (> #4 sieve)	Sand % (#4 to #200 sieve)	Fines % (< #200 sieve)		Cohesion p.s.f.	Internal Friction Angle
					②	ZANETTA DRIVE - approximately 2 inch asphalt over 6 inches aggregate base										
1			5			FILL - POORLY GRADED SAND - brown to dark brown - fine-grained sand - very little cohesion - very loose - moist	4	98								
5			2									7	90	1		
						BOTTOM OF BORING AT 6 FEET										
10																
15																
20																
25																

REMARKS: ① Boring drilled on March 23, 2006. See Plate A-1 in Appendix A for definitions of terms.
 ② No free groundwater encountered during drilling.
 ③ Projected existing pipeline depth from Winzler & Kelly 50% Submittal Drawings (2006).

DCM Engineering

WINZLER & KELLY
 Marina Coast Water District
 2005 Marina Sewer Improvement Projects
 Marina, California
LOG OF BORING B-5A

PLATE NO.
B-5A

FILE NO. J-4962-1

APRIL 2006

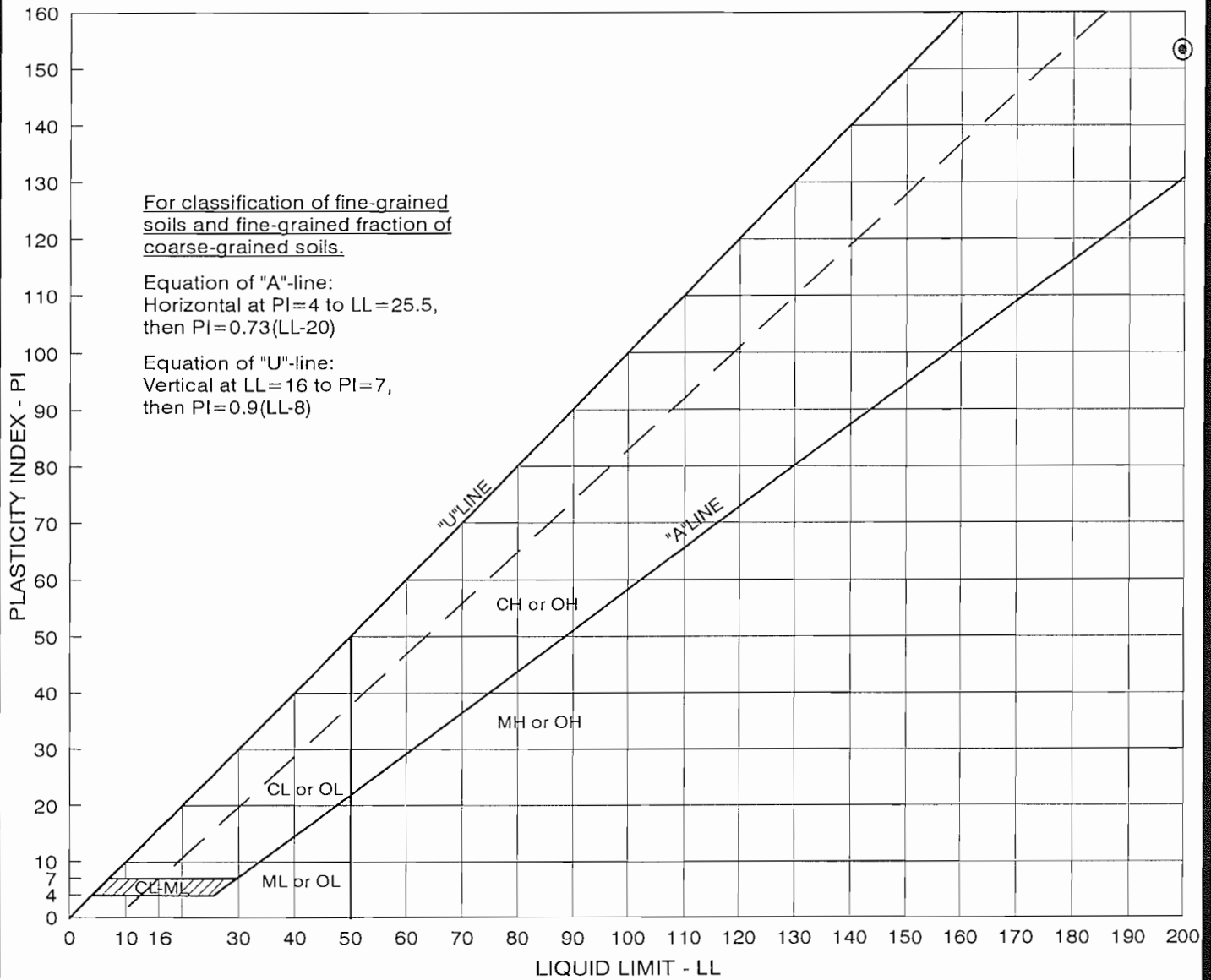

TEST SYMBOL	BORING SAMPLE NO.	DEPTH (ft)	LIQUID LIMIT - LL	PLASTICITY INDEX - PI	RATIO ^①	GROUP SYMBOL ^②
⊙	B-1-6B	18½-19	199	153	0.35	OH

① If ratio of Liquid Limit (oven dried) to Liquid Limit (not dried) is less than 0.75, specimen classifies as organic
 ② Classification of fines < 0.425mm

DCM Engineering

WINZLER & KELLY
 Marina Coast Water District
 2005 Marina Sewer Improvement Projects
 Marina, California
PLASTICITY INDEX

PLATE NO.

C-1

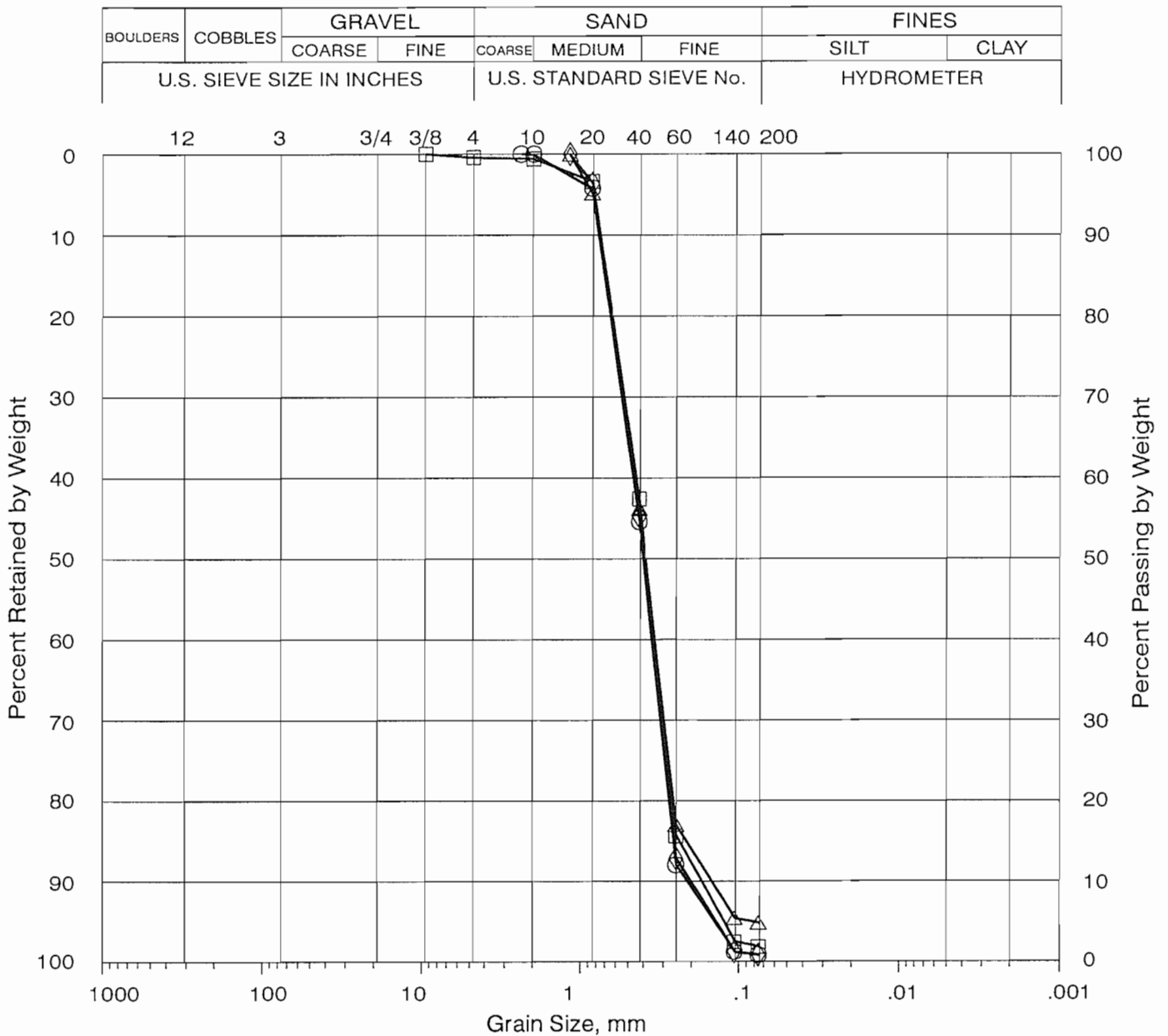

TEST SYMBOL	BORING SAMPLE NO.	DEPTH (feet)	GROUP SYMBOL	DESCRIPTION (based on grain size)
○	B-2-2	4½-6	SP	poorly graded sand
□	B-2-4	9½-11	SP	poorly graded sand
△	B-3-1A	6-6½	SP	poorly graded sand
◇	B-3-3	9½-11	SP	poorly graded sand

NOTE:

The largest particle (grain) size that could have been sampled from our borings by our sample barrels is a function of the inside diameter of the sample barrels used (see Plate A-1). Therefore, there may be larger particles (e.g., coarse gravel, cobbles or boulders) in the soils sampled than reflected on the boring logs and grain size distribution curves provided in this report.

DCM Engineering

WINZLER & KELLY
 Marina Coast Water District
 2005 Marina Sewer Improvement Projects
 Marina, California

PLATE NO.

C-2

FILE NO. J-4962-1

APRIL 2006

GRAIN SIZE ANALYSIS

(2 of 3)

BOULDERS	COBBLES	GRAVEL		SAND			FINES	
		COARSE	FINE	COARSE	MEDIUM	FINE	SILT	CLAY
U.S. SIEVE SIZE IN INCHES				U.S. STANDARD SIEVE No.			HYDROMETER	

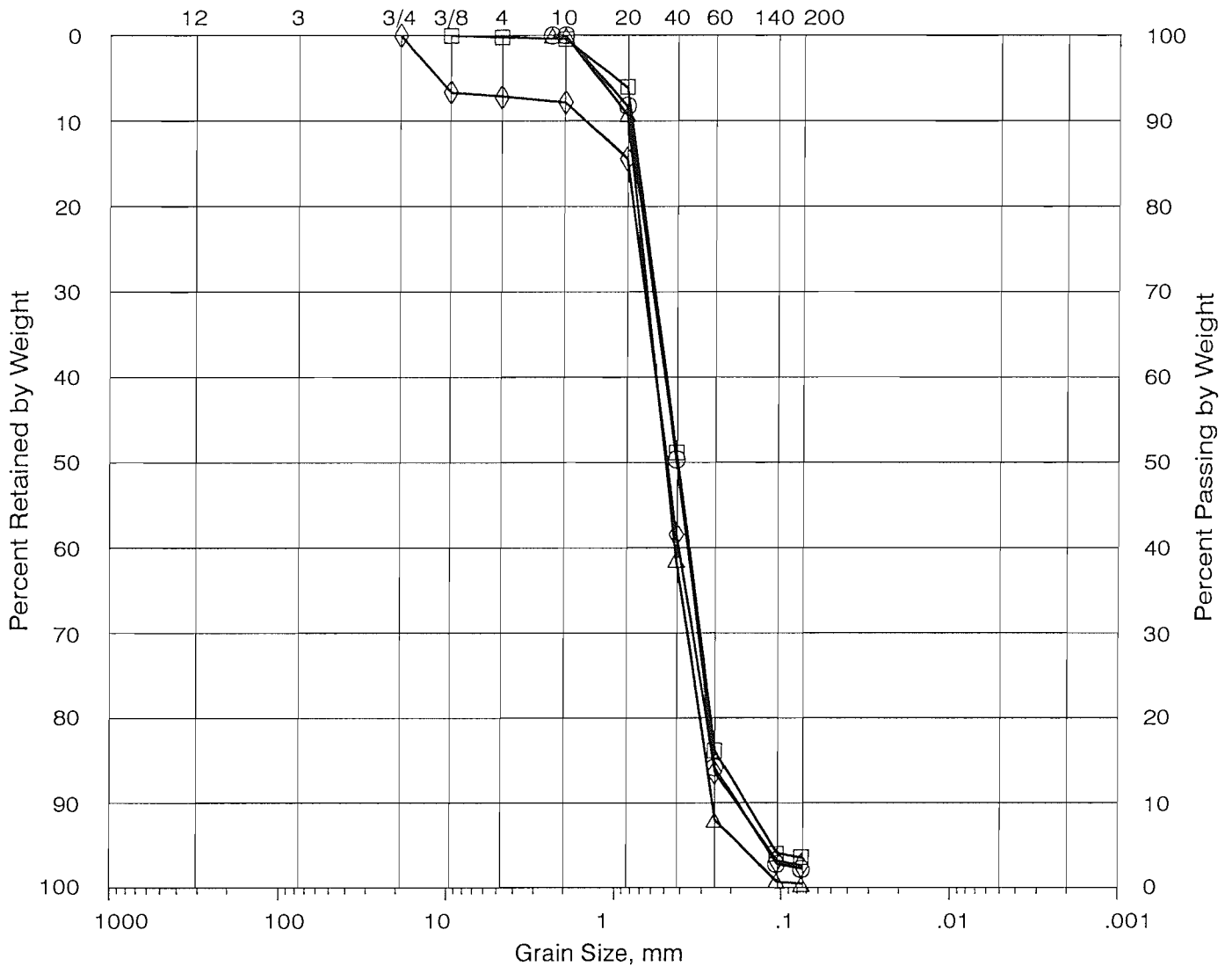

UNCONFINED COMPRESSION TEST

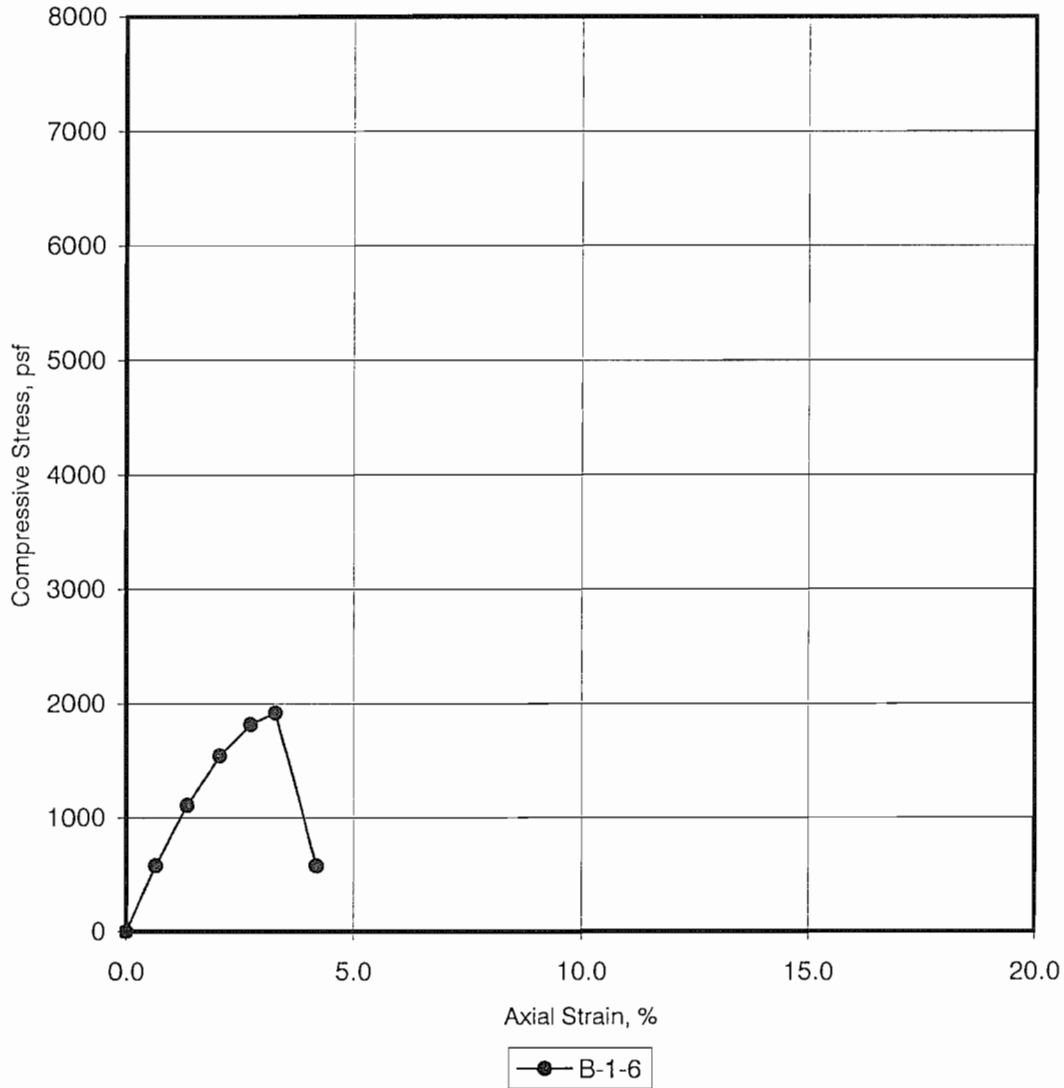

BORING SAMPLE NO.	B-1-6
MAXIMUM UNCONFINED STRESS, psf	1920
% STRAIN @ PEAK STRESS	3.3
DEPTH, ft.	19-19½
WATER CONTENT, %	134
DRY DENSITY, pcf	36
SATURATION, %	97

Maximum Unconfined Stress cut-off = 15% strain
 Average Strain Rate = 0.07 in/min.

DCM Engineering

WINZLER & KELLY
 Marina Coast Water District
 2005 Marina Sewer Improvement Projects
 Marina, California

PLATE NO.

C-3

FILE NO. J-4962-1

APRIL 2006

UNCONFINED COMPRESSION

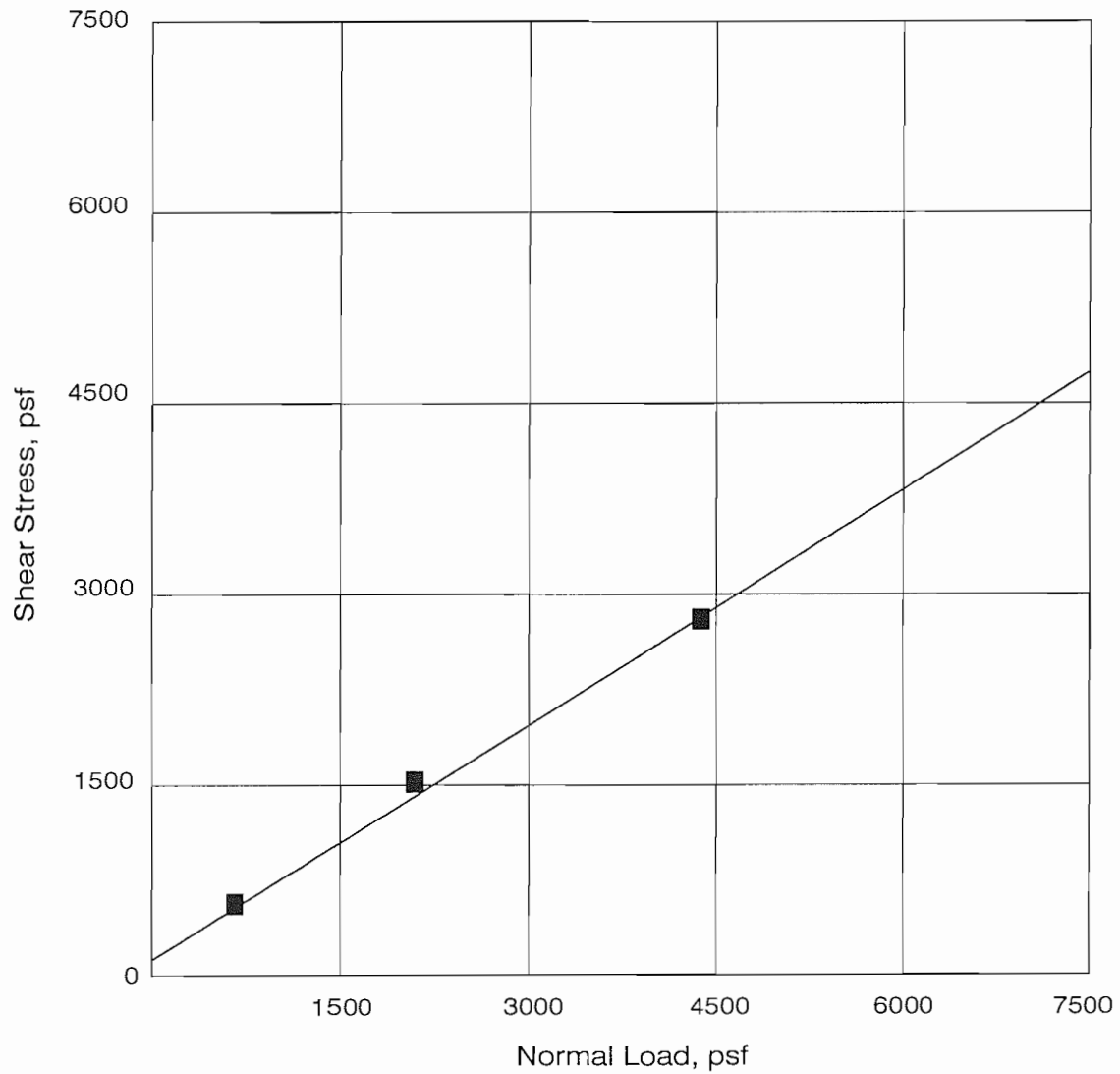

TEST SYMBOL	GRAPH LINE	BORING SAMPLE NO.	DEPTH (ft)	COHESION (p.s.f.)	INTERNAL FRICTION ANGLE (degrees)	AVE. DRY DENSITY (pcf)/ MOISTURE CONTENT (%)	
						BEFORE TEST	AFTER TEST
■	—	B-1-2B	8½-9	60	32	101/2	104/18

DCM Engineering

WINZLER & KELLY
 Marina Coast Water District
 2005 Marina Sewer Improvement Projects
 Marina, California
DIRECT SHEAR

PLATE NO.

C-4

FILE NO. J-4962-1

APRIL 2006

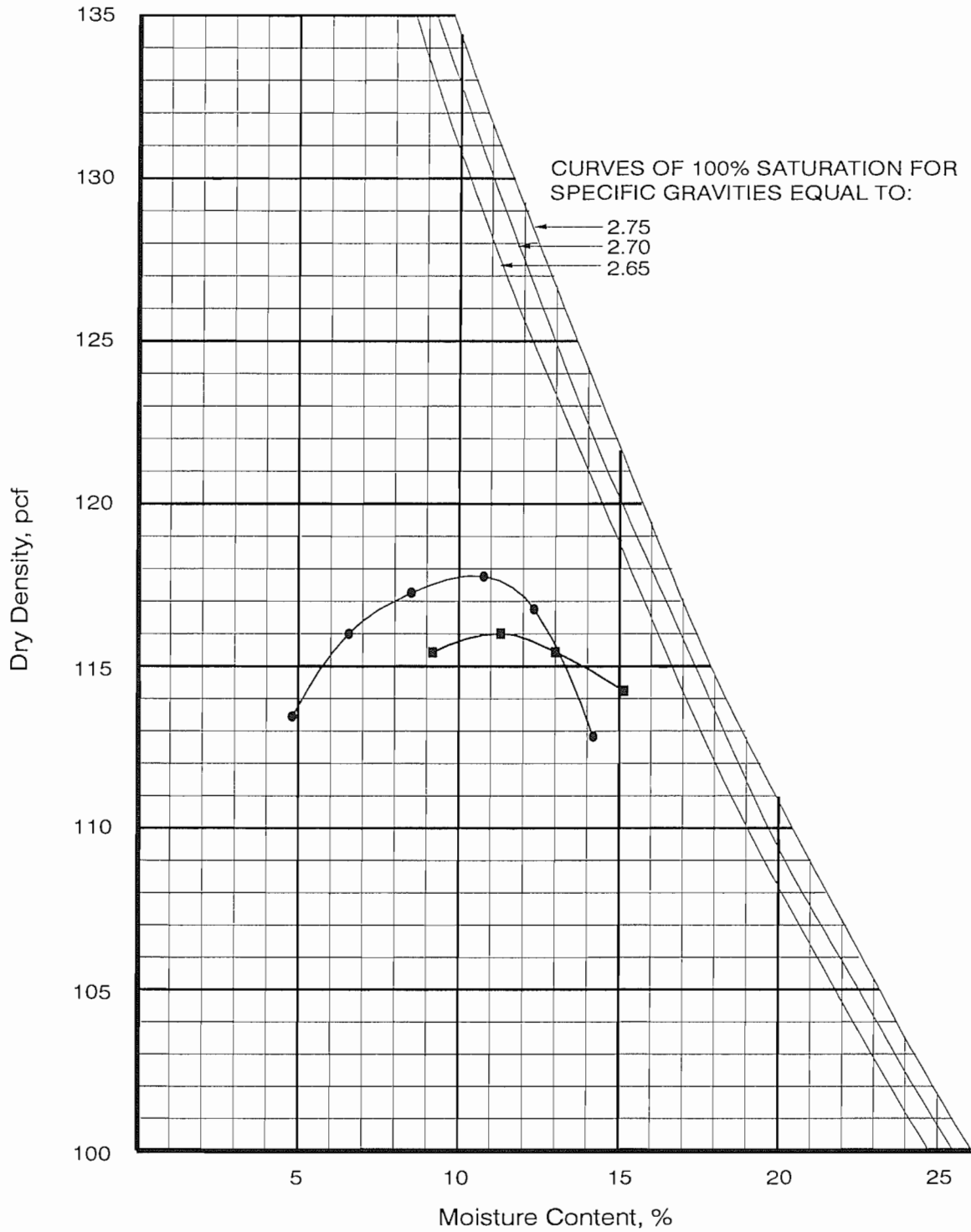

TEST SYMBOL	SAMPLE NO.	DESCRIPTION	MAXIMUM DRY DENSITY (pcf)	OPTIMUM MOISTURE CONTENT (%)
●	B-3A-1	poorly graded sand	117.8	10.2
■	B-4A	poorly graded sand	116.0	11.3

TEST METHOD A.S.T.M. D1557-91 Procedure

DCM Engineering

WINZLER & KELLY
 Marina Coast Water District
 2005 Marina Sewer Improvement Projects
 Marina, California
**MOISTURE-DENSITY
 RELATIONSHIP**

PLATE NO.

C-5

FILE NO. J-4962-1

APRIL 2006

CORROSION TESTS and RESULTS

BORING SAMPLE NO.	RESISTIVITY (ohm-cm)		REDOX (mv)	pH	SULFIDES	SULFATES (ppm)	CHLORIDES (ppm)
	as-received	saturated					
B-1-2B	>54,814	15,801	+265	6.19	Nil	61.1	46.1
B-2-1	>54,814	7,728	+336	5.66	Nil	58.7	35.3
B-4-3	n/a	20,000	+450	6.9	Not Detected	Not Detected	Not Detected

Test Notes:

1. Appendix A of ANSI/AWWA C105/A215, TABLE A, provides soil test methods and evaluation for conditions corrosive to gray or ductile-cast iron pipe and fittings.
2. The above tests (excluding redox and sulfides) were performed in accordance with the following Caltrans Test Methods:
 - a. California Test 643 (1993): METHOD FOR ESTIMATING THE SERVICE LIFE OF STEEL CULVERTS
 - b. California Test 532 (1993): METHOD FOR ESTIMATING THE TIME TO CORROSION OF REINFORCED CONCRETE SUBSTRUCTURES
 - c. California Test 422 (1978): METHOD OF TESTING SOILS AND WATERS FOR CHLORIDE CONTENT
 - d. California Test 417 (1986): METHOD OF TESTING SOILS AND WATERS FOR SULFATE CONTENT
3. ASTM D4568: METHOD OF TESTING SOILS FOR SULFIDE CONTENT.
4. Testing for samples B-1-2B and B-2-1 provided by ConCeCo/Matcor Engineering, Inc.
5. Testing for sample B-4-3 provided by Cerco Analytical Inc.

DCM Engineering

WINZLER & KELLY
 Marina Coast Water District
 2005 Marina Sewer Improvement Projects
 Marina, California
CORROSION TEST RESULTS

PLATE NO.

C-6

Fugro 2004¹

¹ Please see Figure 5 for full citation.

North Campus Community Plan

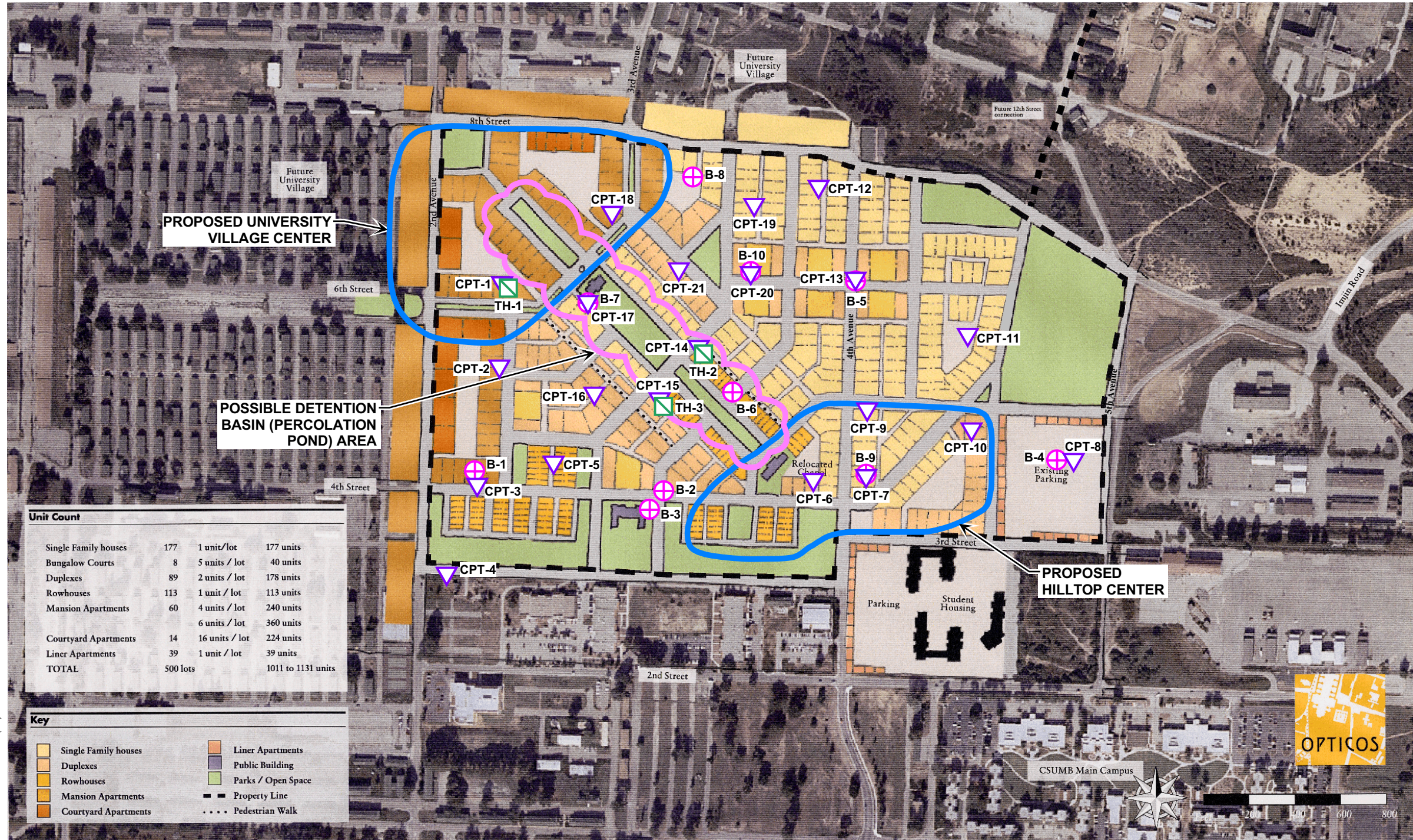

LEGEND

- B-1 Approximate boring location
- CPT-1 Approximate CPT location
- TH-1 Approximate percolation test hole location

- Notes:**
1. Locations shown are approximate.
 2. Adjacent boring/CPT () for correlative purposes.

Unit Count			
Single Family houses	177	1 unit/lot	177 units
Bungalow Courts	8	5 units / lot	40 units
Duplexes	89	2 units / lot	178 units
Rowhouses	113	1 unit / lot	113 units
Mansion Apartments	60	4 units / lot	240 units
		6 units / lot	360 units
Courtyard Apartments	14	16 units / lot	224 units
Liner Apartments	39	1 unit / lot	39 units
TOTAL	500 lots		1011 to 1131 units

Key	
	Single Family houses
	Duplexes
	Rowhouses
	Mansion Apartments
	Courtyard Apartments
	Liner Apartments
	Public Building
	Parks / Open Space
	Property Line
	Pedestrian Walk

200403350.0013350.001site.dwg(1-6)

Cal State University at Monterey Bay

1.1

BASE MAP SOURCE: Denise Duffy & Associates, Inc. (2004).

**SITE LAYOUT AND
EXPLORATION PLAN**
North Campus Housing
California State University
Monterey Bay

APPENDIX A FIELD EXPLORATION

The field exploration for this geotechnical study consisted of advancing 21 Cone Penetration Test (CPT) soundings on March 2, 2004 and drilling ten hollow-stem-auger borings on March 8 through 10, 2004. The approximate locations of the CPT soundings and borings performed for this study are shown on Plate 2 – Exploration Location Plan. The locations of the CPT soundings and borings were determined with a GPS beacon receiver. The resulting locations have an estimated horizontal accuracy of about 10 feet.

Ground surface elevations at CPT and boring locations were estimated from the elevations shown on Plate 2. Elevations are referenced to mean sea level (msl).

BORINGS

Hollow-stem-auger drilling services were performed by Fugro Geosciences of Oakland, California. The borings were advanced using a truck-mounted CME 75 drilling rig equipped with 8-inch-diameter hollow-stem-augers. The drilling was performed under the observation of a Fugro staff engineer, who prepared field logs of the soil conditions and obtained soil samples for laboratory observation and testing. The soils were classified in the field in general accordance with ASTM D2487. Borings B-1 through B-8 were excavated to depths between about 30 and 50 feet below the ground surface. Borings B-9 and B-10 were excavated to depths of about 6½ feet and 10 feet below the ground surface (respectively), primarily to extract Shelby tube samples of silty sand materials encountered in adjacent CPT soundings CPT-7 and CPT-20. Upon completion, the borings were backfilled with cuttings and where appropriate, cold asphalt patch in the upper several inches.

Sampling

During drilling operations, drive samples were obtained from the borings using either a modified California or Standard Penetration Test (SPT) sampler. The modified California sampler has a 3-inch outside diameter and a 2-3/8-inch inside diameter. The samplers were driven 18 inches into the material at the bottom of the boring using a 140-pound automatic trip hammer with a 30-inch drop. The number of blows required to drive the California or SPT sampler the last 12 inches was recorded on the boring logs. Additionally, Shelby push-tube samples were extracted from Borings B-9 and B-10. Recovered samples were placed in transport containers and returned to the laboratory for further classification and testing.

Boring Logs

Logs of the borings, showing depths and descriptions of soils encountered, geologic structure where applicable, vertical locations of samples, sampler blow counts, and results of density and moisture content tests, are presented on Plates A-1 through A-10 - Log of Boring. A legend of symbols typically used on the boring logs is presented on Plate A-11 - Key to Terms and Symbols Used on Logs. The logs represent the interpretation of field logs and tests, interpolation between samples, and the results of laboratory observation and tests. The stratification lines are approximate boundaries between soil types; the transitions can be gradual.



CONE PENETRATION TEST SOUNDINGS

CPT soundings were performed by Fugro Geosciences, Inc., of Santa Fe Springs, California. The cone penetrometer is mounted on a 20-ton truck and consists of a 38-millimeter-diameter rod with a 10-square-centimeter, 60-degree-apex-angle cone at the base. The cone is equipped with electronic load cells that measure both point resistance and frictional resistance between the soils and the cylinder side of the cone. The primary purpose of performing CPTs was to provide a nearly continuous log of the earth materials and soil stratigraphy between boring locations and sample depths.

Although many factors influence CPT profiles, including: physical cone properties, vertical effective stress, pore pressure, soil compressibility and fabric, and depositional characteristics, the classifications are generally consistent with the laboratory classification data and with the visual descriptions made during the soil borings (Plate A.33 presents one example of soil classification using CPT data).

CPT soundings were advanced to depths between about 30 and 50 feet below the ground surface. Upon completion, the CPT soundings were backfilled with bentonite pellets. Data results of CPT soundings consisting of plots of sleeve friction, tip resistance, and friction ratio versus depth are presented on Plates A-12 through A-32- Log of CPT. A soil classification chart is presented on Plate A-33 - CPT Correlation Chart.





ELEVATION, ft	DEPTH, ft	MATERIAL SYMBOL	SAMPLE NO.	SAMPLERS	SAMPLER BLOW COUNT	LOCATION: Per Plate 2 N 2,134,401.09594 E 5,738,070.41674 NAD83, State Plane, CA Zone 4, Feet SURFACE EL: 147 ft +/- (rel. MSL datum)	UNIT WET WEIGHT, pcf	UNIT DRY WEIGHT, pcf	WATER CONTENT, %	% PASSING #200 SIEVE	LIQUID LIMIT, %	PLASTICITY INDEX, %	UNDRAINED SHEAR STRENGTH, S _u , ksf		
MATERIAL DESCRIPTION															
146	2		B-1		(22)	Fine to Medium SAND with silt (SP-SM): dense, dark brown, moist	109	99	10	11					
144	4		2		12										
142	6		3		12										
140	8		4		12										
138	10		5		(9)			- loose locally, from 4' to 5.5' - mottled with light brown, from 4.5' to 5'	110	101	8				
136	12		6		7										
134	14		7		7										
132	16		8		8										
130	18		9		9		48	Fine SAND with silt (SP-SM): very dense, light brown, damp to dry			3	20			
128	20		10		10										
126	22		11		11		(22)	Fine SAND (SP): dense, light brown, dry	111	107	4	3			
124	24		12		12										
122	26		13		13		(36)	- very dense, at 21'							
120	28		14		14										
118	30		15		15										
116	32		16		16		(39)								
114	34		17		17										
112	36	17	17		34	- very dense, at 26'									
110	38														
108															

The log and data presented are a simplification of actual conditions encountered at the time of drilling at the drilled location. Subsurface conditions may differ at other locations and with the passage of time.

COMPLETION DEPTH: 51.5 ft
DEPTH TO WATER: Not encountered
BACKFILLED WITH: Cuttings
DRILLING DATE: March 8, 2004

DRILLING METHOD: 8-inch-dia. Hollow Stem Auger
HAMMER TYPE: Automatic Trip
DRILLED BY: Fugro Geosciences
LOGGED BY: N Song
CHECKED BY: C A Wockner

LOG OF BORING NO. B-1
North Campus Housing
California State University
Monterey Bay

PLATE A-1a





ELEVATION, ft	DEPTH, ft	MATERIAL SYMBOL	SAMPLE NO.	SAMPLERS	SAMPLER BLOW COUNT	LOCATION: Per Plate 2 N 2,134,401.09594 E 5,738,070.41674 NAD83, State Plane, CA Zone 4, Feet SURFACE EL: 147 ft +/- (rel. MSL datum)	UNIT WET WEIGHT, pcf	UNIT DRY WEIGHT, pcf	WATER CONTENT, %	% PASSING #200 SIEVE	LIQUID LIMIT, %	PLASTICITY INDEX, %	UNDRAINED SHEAR STRENGTH, S _u , ksf	
MATERIAL DESCRIPTION														
106	42		18		(41)	Fine to Medium SAND (SP): dense, light brown, dry								
104	44		20											
102	46		21		59	- very dense, at 46'								
100	48													
98	50													
96	52		22		(56)	- very dense, grades to fine grained, at 51'								
94	54		23											
92	56													
90	58													
88	60													
86	62													
84	64													
82	66													
80	68													
78	70													
76	72													
74	74													
72	76													
70	78													
68														

The log and data presented are a simplification of actual conditions encountered at the time of drilling at the drilled location. Subsurface conditions may differ at other locations and with the passage of time.

COMPLETION DEPTH: 51.5 ft
 DEPTH TO WATER: Not encountered
 BACKFILLED WITH: Cuttings
 DRILLING DATE: March 8, 2004

DRILLING METHOD: 8-inch-dia. Hollow Stem Auger
 HAMMER TYPE: Automatic Trip
 DRILLED BY: Fugro Geosciences
 LOGGED BY: N Song
 CHECKED BY: C A Wockner

LOG OF BORING NO. B-1
 North Campus Housing
 California State University
 Monterey Bay

PLATE A-1b





ELEVATION, ft	DEPTH, ft	MATERIAL SYMBOL	SAMPLE NO.	SAMPLERS	SAMPLER BLOW COUNT	LOCATION: Per Plate 2 N 2,134,316.01760 E 5,738,904.25227 NAD83, State Plane, CA Zone 4, Feet SURFACE EL: 159 ft +/- (rel. MSL datum)	UNIT WET WEIGHT, pcf	UNIT DRY WEIGHT, pcf	WATER CONTENT, %	% PASSING #200 SIEVE	LIQUID LIMIT, %	PLASTICITY INDEX, %	UNDRAINED SHEAR STRENGTH, S _u , ksf		
MATERIAL DESCRIPTION															
158	2		1		(15)	Fine SAND with silt (SP): medium dense, dark brown, damp to moist - locally grades to brown, at 4.5'									
			2				(17)	107	100	6					
156	4		3				(14)	102	96	6					
			4		(14)		106	100	5						
154	6		5												
			6		(25)										
152	8		7		(25)		Fine SAND (SP): dense, light brown, damp	105	99	5					
150	10		8		(37)										
148	12		9		(37)		- very dense, at 16'								
146	14	10		(51)											
144	16	11		(51)	- very dense, at 20'										
142	18	12		28											
140	20	13		28											
138	22	14		31											
136	24	15		31											
134	26	16													
132	28	17													
130	30	18													
128	32	19													
126	34	20													
124	36	21													
122	38	22													
120		23													

The log and data presented are a simplification of actual conditions encountered at the time of drilling at the drilled location. Subsurface conditions may differ at other locations and with the passage of time.

COMPLETION DEPTH: 31.0 ft
DEPTH TO WATER: Not encountered
BACKFILLED WITH: Cuttings
DRILLING DATE: March 8, 2004

DRILLING METHOD: 8-inch-dia. Hollow Stem Auger
HAMMER TYPE: Automatic Trip
DRILLED BY: Fugro Geosciences
LOGGED BY: N Song
CHECKED BY: C A Wockner

LOG OF BORING NO. B-2
North Campus Housing
California State University
Monterey Bay





ELEVATION, ft	DEPTH, ft	MATERIAL SYMBOL	SAMPLE NO.	SAMPLERS	SAMPLER BLOW COUNT	LOCATION: Per Plate 2 N 2,134,232.82076 E 5,738,843.13181 NAD83, State Plane, CA Zone 4, Feet SURFACE EL: 157 ft +/- (rel. MSL datum)	UNIT WET WEIGHT, pcf	UNIT DRY WEIGHT, pcf	WATER CONTENT, %	% PASSING #200 SIEVE	LIQUID LIMIT, %	PLASTICITY INDEX, %	UNDRAINED SHEAR STRENGTH, S _u , ksf	
MATERIAL DESCRIPTION														
156	2		B 1		(14)	Fine to Medium SAND (SP): medium dense to dense, dark brown, damp	115	107	8	6				
			B 2		(14)									
154	4			3		(17)	Fine SAND (SP): dense, light brown, damp to moist, trace silt	120	115	4				
				4		(17)								
152	6			5		(17)	Fine SAND (SP): dense, light brown, damp to moist, trace silt	105	99	6	4			
				6		(17)								
150	8													
148	10													
146	12			7		(21)	- fine to medium grained, at 10.5'	102	96	6				
				8		(21)								
144	14													
142	16			9		27	- very dense, at 15'							
140	18													
138	20													
136	22			10		(38)	- very dense, at 25'							
			11	(38)										
134	24													
132	26		12		42	- very dense, at 31'								
130	28													
128	30													
126	32		13		(54)	- very dense, at 36'								
			14		(54)									
124	34													
122	36		15		53	- very dense, at 36'								
120	38													
118			16		(54)									

The log and data presented are a simplification of actual conditions encountered at the time of drilling at the drilled location. Subsurface conditions may differ at other locations and with the passage of time.

COMPLETION DEPTH: 51.0 ft
 DEPTH TO WATER: Not encountered
 BACKFILLED WITH: Cuttings
 DRILLING DATE: March 10, 2004

DRILLING METHOD: 8-inch-dia. Hollow Stem Auger
 HAMMER TYPE: Automatic Trip
 DRILLED BY: Fugro Geosciences
 LOGGED BY: N Song
 CHECKED BY: C A Wockner

LOG OF BORING NO. B-3
 North Campus Housing
 California State University
 Monterey Bay

PLATE A-3a





ELEVATION, ft	DEPTH, ft	MATERIAL SYMBOL	SAMPLE NO.	SAMPLERS	SAMPLER BLOW COUNT	LOCATION: Per Plate 2 N 2,134,232.82076 E 5,738,843.13181 NAD83, State Plane, CA Zone 4, Feet SURFACE EL: 157 ft +/- (rel. MSL datum)	UNIT WET WEIGHT, pcf	UNIT DRY WEIGHT, pcf	WATER CONTENT, %	% PASSING #200 SIEVE	LIQUID LIMIT, %	PLASTICITY INDEX, %	UNDRAINED SHEAR STRENGTH, S _u , ksf			
MATERIAL DESCRIPTION																
116	42	[Dotted pattern symbol]	17	[Sampler symbol]	62	Fine SAND (SP): very dense, light brown, damp to moist										
114	44															
112	46															
110	48															
108	50						20		35	- dense, at 50'						
106	52															
104	54															
102	56															
100	58															
98	60															
96	62															
94	64															
92	66															
90	68															
88	70															
86	72															
84	74															
82	76															
80	78															
78																

The log and data presented are a simplification of actual conditions encountered at the time of drilling at the drilled location. Subsurface conditions may differ at other locations and with the passage of time.

COMPLETION DEPTH: 51.0 ft
 DEPTH TO WATER: Not encountered
 BACKFILLED WITH: Cuttings
 DRILLING DATE: March 10, 2004

DRILLING METHOD: 8-inch-dia. Hollow Stem Auger
 HAMMER TYPE: Automatic Trip
 DRILLED BY: Fugro Geosciences
 LOGGED BY: N Song
 CHECKED BY: C A Wockner

LOG OF BORING NO. B-3
 North Campus Housing
 California State University
 Monterey Bay

PLATE A-3b





ELEVATION, ft	DEPTH, ft	MATERIAL SYMBOL	SAMPLE NO.	SAMPLERS	SAMPLER BLOW COUNT	LOCATION: Per Plate 2 N 2,134,447.47676 E 5,740,639.41804 NAD83, State Plane, CA Zone 4, Feet SURFACE EL: 162 ft +/- (rel. MSL datum)	UNIT WET WEIGHT, pcf	UNIT DRY WEIGHT, pcf	WATER CONTENT, %	% PASSING #200 SIEVE	LIQUID LIMIT, %	PLASTICITY INDEX, %	UNDRAINED SHEAR STRENGTH, S _u , ksf		
MATERIAL DESCRIPTION															
-160	2		B-1		(23)	ARTIFICIAL FILL (af) Fine to Medium SAND with silt and gravel (SP-SM); dense, dark brown, damp to moist, trace pieces of glass - mottled rusty brown and olive, some gravel, at 3'	122	111	10	10					
			B-2					118	112	6					
			B-3												
			B-4					(18)							
-158	4		B-5						99	87	14				
			B-6					(18)							
			B-7						92	85	9				
-156	6					Fine SAND (SP): dense, light brown, damp to moist - fine to medium grained, at 15' - very dense, at 20' - very dense, at 25'									
-154	8		8		16										
-152	10									4	2				
-150	12														
-148	14														
-146	16		9				(28)								
			10												
-144	18														
-142	20			11			34								
-140	22														
-138	24														
-136	26			12			(72)								
-134	28														
-132	30		13		26										
-130	32														
-128	34														
-126	36														
-124	38														

The log and data presented are a simplification of actual conditions encountered at the time of drilling at the drilled location. Subsurface conditions may differ at other locations and with the passage of time.

COMPLETION DEPTH: 31.0 ft
 DEPTH TO WATER: Not encountered
 BACKFILLED WITH: Cuttings
 DRILLING DATE: March 10, 2004

DRILLING METHOD: 8-inch-dia. Hollow Stem Auger
 HAMMER TYPE: Automatic Trip
 DRILLED BY: Fugro Geosciences
 LOGGED BY: N Song
 CHECKED BY: C A Wockner

LOG OF BORING NO. B-4
 North Campus Housing
 California State University
 Monterey Bay





ELEVATION, ft	DEPTH, ft	MATERIAL SYMBOL	SAMPLE NO.	SAMPLERS	SAMPLER BLOW COUNT	LOCATION: Per Plate 2 N 2,135,345.64545 E 5,739,814.64435 NAD83, State Plane, CA Zone 4, Feet SURFACE EL: 171 ft +/- (rel. MSL datum)	UNIT WET WEIGHT, pcf	UNIT DRY WEIGHT, pcf	WATER CONTENT, %	% PASSING #200 SIEVE	LIQUID LIMIT, %	PLASTICITY INDEX, %	UNDRAINED SHEAR STRENGTH, S _u , ksf
MATERIAL DESCRIPTION													
170						1.5" Asphalt Concrete							
						5" Base							
	2		B 1		(27)	Fine SAND (SP): dense, brown, moist, trace silt	102	99	3	4			
			2		(37)	- grades to light brown, damp to moist, at 2'							
168			3		(37)								
	4		4		(37)	- locally fine to medium grained, from 3' to 3.5'	97	95	3				
			5		(23)								
166			6		(23)		106	104	2				
	6		7		(23)								
164													
	8												
162													
	10		8		21								
160										4			
	12												
158													
	14												
156			9		(33)								
	16		10		(33)								
			11		(33)								
154													
	18												
152													
	20		12		32								
150						- very dense, at 21'							
	22												
148													
	24												
146			13		(48)								
	26		14		(48)								
			15		(48)	- very dense, fine to medium grained, at 26'							
144													
	28												
142													
	30		16		50								
140						- very dense, at 31'							
	32												
138													
	34												
136			17		(57)								
	36		18		(57)								
			19		(57)	- very dense, fine to medium grained, from 35' to 36'							
134													
	38												
132			20		45								

The log and data presented are a simplification of actual conditions encountered at the time of drilling at the drilled location. Subsurface conditions may differ at other locations and with the passage of time.

COMPLETION DEPTH: 51.0 ft
DEPTH TO WATER: Not encountered
BACKFILLED WITH: Cuttings
DRILLING DATE: March 10, 2004

DRILLING METHOD: 8-inch-dia. Hollow Stem Auger
HAMMER TYPE: Automatic Trip
DRILLED BY: Fugro Geosciences
LOGGED BY: N Song
CHECKED BY: C A Wockner

LOG OF BORING NO. B-5
North Campus Housing
California State University
Monterey Bay

PLATE A-5a





ELEVATION, ft	DEPTH, ft	MATERIAL SYMBOL	SAMPLE NO.	SAMPLERS	SAMPLER BLOW COUNT	LOCATION: Per Plate 2 N 2,135,345.64545 E 5,739,814.64435 NAD83, State Plane, CA Zone 4, Feet SURFACE EL: 171 ft +/- (rel. MSL datum)	UNIT WET WEIGHT, pcf	UNIT DRY WEIGHT, pcf	WATER CONTENT, %	% PASSING #200 SIEVE	LIQUID LIMIT, %	PLASTICITY INDEX, %	UNDRAINED SHEAR STRENGTH, S _u , ksf				
MATERIAL DESCRIPTION																	
130	42	[Dotted pattern symbol]	21 22 23	[X symbol]	(80)	Fine SAND (SP): very dense, brown, moist, trace silt											
128	44																
126	46																
124	48																
122	50																
120	52																
118	54																
116	56																
114	58																
112	60																
110	62																
108	64																
106	66																
104	68																
102	70																
100	72																
98	74																
96	76																
94	78																
92																	

The log and data presented are a simplification of actual conditions encountered at the time of drilling at the drilled location. Subsurface conditions may differ at other locations and with the passage of time.

COMPLETION DEPTH: 51.0 ft
 DEPTH TO WATER: Not encountered
 BACKFILLED WITH: Cuttings
 DRILLING DATE: March 10, 2004

DRILLING METHOD: 8-inch-dia. Hollow Stem Auger
 HAMMER TYPE: Automatic Trip
 DRILLED BY: Fugro Geosciences
 LOGGED BY: N Song
 CHECKED BY: C A Wockner

LOG OF BORING NO. B-5
 North Campus Housing
 California State University
 Monterey Bay

PLATE A-5b





ELEVATION, ft	DEPTH, ft	MATERIAL SYMBOL	SAMPLE NO.	SAMPLERS	SAMPLER BLOW COUNT	LOCATION: Per Plate 2 N 2,134,750.19892 E 5,739,210.38080 NAD83, State Plane, CA Zone 4, Feet SURFACE EL: 163 ft +/- (rel. MSL datum)	UNIT WET WEIGHT, pcf	UNIT DRY WEIGHT, pcf	WATER CONTENT, %	% PASSING #200 SIEVE	LIQUID LIMIT, %	PLASTICITY INDEX, %	UNDRAINED SHEAR STRENGTH, S _u , ksf
MATERIAL DESCRIPTION													
162						3" Asphalt Concrete							
	2		B 1		(3)	4" Base	118	107	11	13			
	4		2		(6)	Silty Fine SAND (SM): loose to medium dense, dark brown, moist, fine to medium grained	95	90	6				
160			3		(6)		18	17	5				
	4		4		(12)		105	100	6				
158			5		(12)								
	6		6		(17)	Fine SAND (SP): dense, light brown, moist, trace to some silt							
156			7		(17)		106	102	4	2			
	8		8		(17)								
154			9		(17)								
	10		10		22								
152			11		(49)	- colors to brown, at 19.5' - very dense, at 20'							
	12		12		(49)		109	102	7				
150			13		(49)								
	14		14		26								
148			15		(41)	- grades to light brown, at 30'							
	16		16		(41)								
146			17		(41)								
	18		18		37								
144			18		37	- very dense, at 36'							
	20		18		37								
142			18		37								
	22		18		37								
140			18		37								
	24		18		37								
138			18		37								
	26		18		37								
136			18		37								
	28		18		37								
134			18		37								
	30		18		37								
132			18		37								
	32		18		37								
130			18		37								
	34		18		37								
128			18		37								
	36		18		37								
126			18		37								
	38		18		37								
124			18		37								

The log and data presented are a simplification of actual conditions encountered at the time of drilling at the drilled location. Subsurface conditions may differ at other locations and with the passage of time.

COMPLETION DEPTH: 51.0 ft
DEPTH TO WATER: Not encountered
BACKFILLED WITH: Cuttings
DRILLING DATE: March 9, 2004

DRILLING METHOD: 8-inch-dia. Hollow Stem Auger
HAMMER TYPE: Automatic Trip
DRILLED BY: Fugro Geosciences
LOGGED BY: N Song
CHECKED BY: C A Wockner

LOG OF BORING NO. B-6
North Campus Housing
California State University
Monterey Bay

PLATE A-6a





ELEVATION, ft	DEPTH, ft	MATERIAL SYMBOL	SAMPLE NO.	SAMPLERS	SAMPLER BLOW COUNT	LOCATION: Per Plate 2 N 2,134,750.19892 E 5,739,210.38080 NAD83, State Plane, CA Zone 4, Feet SURFACE EL: 163 ft +/- (rel. MSL datum)	UNIT WET WEIGHT, pcf	UNIT DRY WEIGHT, pcf	WATER CONTENT, %	% PASSING #200 SIEVE	LIQUID LIMIT, %	PLASTICITY INDEX, %	UNDRAINED SHEAR STRENGTH, S _u , ksf
MATERIAL DESCRIPTION													
122	42	[Dotted pattern]	19	[Symbol]	(41)	Fine to Medium SAND (SP): dense, light brown, moist - dense, fine to medium grained, at 41' - very dense, at 46'							
120	44		20										
118	46		21	[X symbol]	38								
116	48												
114	50		22	[Symbol]	(42)								
112	52		23	[Symbol]									
110	54		24	[Symbol]									
108	56												
106	58												
104	60												
102	62												
100	64												
98	66												
96	68												
94	70												
92	72												
90	74												
88	76												
86	78												
84													

The log and data presented are a simplification of actual conditions encountered at the time of drilling at the drilled location. Subsurface conditions may differ at other locations and with the passage of time.

COMPLETION DEPTH: 51.0 ft
DEPTH TO WATER: Not encountered
BACKFILLED WITH: Cuttings
DRILLING DATE: March 9, 2004

DRILLING METHOD: 8-inch-dia. Hollow Stem Auger
HAMMER TYPE: Automatic Trip
DRILLED BY: Fugro Geosciences
LOGGED BY: N Song
CHECKED BY: C A Wockner

LOG OF BORING NO. B-6
North Campus Housing
California State University
Monterey Bay

PLATE A-6b





ELEVATION, ft	DEPTH, ft	MATERIAL SYMBOL	SAMPLE NO.	SAMPLERS	SAMPLER BLOW COUNT	LOCATION: Per Plate 2 N 2,135,145.22070 E 5,738,571.46435 NAD83, State Plane, CA Zone 4, Feet SURFACE EL: 138 ft +/- (rel. MSL datum)	UNIT WET WEIGHT, pcf	UNIT DRY WEIGHT, pcf	WATER CONTENT, %	% PASSING #200 SIEVE	LIQUID LIMIT, %	PLASTICITY INDEX, %	UNDRAINED SHEAR STRENGTH, S _u , ksf
MATERIAL DESCRIPTION													
						2" Asphalt Concrete			4				
						4" Base							
						Fine to Medium SAND (SP): dense, brown, moist - grades to light brown, at 1.5'	106	98	8	4			
136	2		B 1		(30)		100	96	4				
			B 2										
			B 3										
			B 4		(21)								
134	4		B 5				99	95	5				
			B 6		(26)								
			B 7				107	102	5				
132	6					- grades to fine grained, at 5.5'							
130	8												
128	10		8		(29)								
126	12		9				97	93	4	1			
124	14												
122	16		10		21					3			
120	18												
118	20		11		(36)								
116	22		12										
114	24												
112	26		13		28								
110	28												
108	30		14		(36)								
106	32		15										
104	34												
102	36		16		52	very dense, at 36'							
100	38												

The log and data presented are a simplification of actual conditions encountered at the time of drilling at the drilled location. Subsurface conditions may differ at other locations and with the passage of time.

COMPLETION DEPTH: 51.0 ft
DEPTH TO WATER: Not encountered
BACKFILLED WITH: Cuttings
DRILLING DATE: March 10, 2004

DRILLING METHOD: 8-inch-dia. Hollow Stem Auger
HAMMER TYPE: Automatic Trip
DRILLED BY: Fugro Geosciences
LOGGED BY: N Song
CHECKED BY: C A Wockner

LOG OF BORING NO. B-7
North Campus Housing
California State University
Monterey Bay

PLATE A-7a





ELEVATION, ft	DEPTH, ft	MATERIAL SYMBOL	SAMPLE NO.	SAMPLERS	SAMPLER BLOW COUNT	LOCATION: Per Plate 2 N 2,135,145.22070 E 5,738,571.46435 NAD83, State Plane, CA Zone 4, Feet SURFACE EL: 138 ft +/- (rel. MSL datum)	UNIT WET WEIGHT, pcf	UNIT DRY WEIGHT, pcf	WATER CONTENT, %	% PASSING #200 SIEVE	LIQUID LIMIT, %	PLASTICITY INDEX, %	UNDRAINED SHEAR STRENGTH, S _u , ksf
						MATERIAL DESCRIPTION							
			17		(39)	Fine to Medium SAND (SP): dense, brown, moist							
96	42		18										
94	44		19	X	33								
92	46		20	X	41	- very dense, at 50'							
90	48												
88	50												
86	52												
84	54												
82	56												
80	58												
78	60												
76	62												
74	64												
72	66												
70	68												
68	70												
66	72												
64	74												
62	76												
60	78												

The log and data presented are a simplification of actual conditions encountered at the time of drilling at the drilled location. Subsurface conditions may differ at other locations and with the passage of time.

COMPLETION DEPTH: 51.0 ft
 DEPTH TO WATER: Not encountered
 BACKFILLED WITH: Cuttings
 DRILLING DATE: March 10, 2004

DRILLING METHOD: 8-inch-dia. Hollow Stem Auger
 HAMMER TYPE: Automatic Trip
 DRILLED BY: Fugro Geosciences
 LOGGED BY: N Song
 CHECKED BY: C A Wockner

LOG OF BORING NO. B-7
 North Campus Housing
 California State University
 Monterey Bay

PLATE A-7b





ELEVATION, ft	DEPTH, ft	MATERIAL SYMBOL	SAMPLE NO.	SAMPLERS	SAMPLER BLOW COUNT	LOCATION: Per Plate 2 N 2,135,696.27309 E 5,739,032.61182 NAD83, State Plane, CA Zone 4, Feet SURFACE EL: 147 ft +/- (rel. MSL datum)	UNIT WET WEIGHT, pcf	UNIT DRY WEIGHT, pcf	WATER CONTENT, %	% PASSING #200 SIEVE	LIQUID LIMIT, %	PLASTICITY INDEX, %	UNDRAINED SHEAR STRENGTH, S _u , ksf
MATERIAL DESCRIPTION													
146	2		1		(23)	2.5" Asphalt Concrete	107	101	6				
			2			4" Base							
144	4		3		(23)	Fine SAND (SP): dense, light brown, moist, trace silt							
142	6		4		(24)								
			5			- mottled with olive color, at 5'							
140	8		6										
138	10		7										
136	12		8										
134	14		9										
132	16		10		21								
130	18		11										
128	20		12		(40)		102	98	4				
126	22		13			- very dense, at 20'							
124	24		14										
122	26		15		(56)	- very dense, at 25'							
120	28		16										
118	30		17		38	- very dense, at 30'							
116	32												
114	34												
112	36												
110	38												
108													

The log and data presented are a simplification of actual conditions encountered at the time of drilling at the drilled location. Subsurface conditions may differ at other locations and with the passage of time.

COMPLETION DEPTH: 31.0 ft
 DEPTH TO WATER: Not encountered
 BACKFILLED WITH: Cuttings
 DRILLING DATE: March 9, 2004

DRILLING METHOD: 8-inch-dia. Hollow Stem Auger
 HAMMER TYPE: Automatic Trip
 DRILLED BY: Fugro Geosciences
 LOGGED BY: N Song
 CHECKED BY: C A Wockner

LOG OF BORING NO. B-8
 North Campus Housing
 California State University
 Monterey Bay





ELEVATION, ft	DEPTH, ft	MATERIAL SYMBOL	SAMPLE NO.	SAMPLERS	SAMPLER BLOW COUNT	LOCATION: Per Plate 2 N 2,134,380.36323 E 5,739,804.05826 NAD83, State Plane, CA Zone 4, Feet SURFACE EL: 176 ft +/- (rel. MSL datum)	UNIT WET WEIGHT, pcf	UNIT DRY WEIGHT, pcf	WATER CONTENT, %	% PASSING #200 SIEVE	LIQUID LIMIT, %	PLASTICITY INDEX, %	UNDRAINED SHEAR STRENGTH, S _u , ksf
MATERIAL DESCRIPTION													
-174	2		B			2" Asphalt Concrete							
-172	4		1			5" Base Silty Fine SAND (SM): brown, damp - grades to dark brown, at 2'				15			
-170	6												
-168	8												
-166	10												
-164	12												
-162	14												
-160	16												
-158	18												
-156	20												
-154	22												
-152	24												
-150	26												
-148	28												
-146	30												
-144	32												
-142	34												
-140	36												
-138	38												

The log and data presented are a simplification of actual conditions encountered at the time of drilling at the drilled location. Subsurface conditions may differ at other locations and with the passage of time.

COMPLETION DEPTH: 6.5 ft
 DEPTH TO WATER: Not encountered
 BACKFILLED WITH: Cuttings
 DRILLING DATE: March 10, 2004

DRILLING METHOD: 8-inch-dia. Hollow Stem Auger
 HAMMER TYPE: Automatic Trip
 DRILLED BY: Fugro Geosciences
 LOGGED BY: N Song
 CHECKED BY: C A Wockner

LOG OF BORING NO. B-9
 North Campus Housing
 California State University
 Monterey Bay





ELEVATION, ft	DEPTH, ft	MATERIAL SYMBOL	SAMPLE NO.	SAMPLERS	SAMPLER BLOW COUNT	LOCATION: Per Plate 2 N 2,135,276.00074 E 5,739,289.31671 NAD83, State Plane, CA Zone 4, Feet SURFACE EL: 156 ft +/- (rel. MSL datum)	UNIT WET WEIGHT, pcf	UNIT DRY WEIGHT, pcf	WATER CONTENT, %	% PASSING #200 SIEVE	LIQUID LIMIT, %	PLASTICITY INDEX, %	UNDRAINED SHEAR STRENGTH, S _u , ksf
MATERIAL DESCRIPTION													
-154	2					2" Asphalt Concrete							
						4" Base							
						Fine SAND (SP): brown, damp to moist							
-152	4					Silty Fine SAND (SM): dark brown, damp to moist							
-150	6		1										
-148	8		B							16			
-146	10												
-144	12												
-142	14												
-140	16												
-138	18												
-136	20												
-134	22												
-132	24												
-130	26												
-128	28												
-126	30												
-124	32												
-122	34												
-120	36												
-118	38												

The log and data presented are a simplification of actual conditions encountered at the time of drilling at the drilled location. Subsurface conditions may differ at other locations and with the passage of time.

COMPLETION DEPTH: 10.0 ft
 DEPTH TO WATER: Not encountered
 BACKFILLED WITH: Cuttings
 DRILLING DATE: March 9, 2004

DRILLING METHOD: 8-inch-dia. Hollow Stem Auger
 HAMMER TYPE: Automatic Trip
 DRILLED BY: Fugro Geosciences
 LOGGED BY: N Song
 CHECKED BY: C A Wockner

LOG OF BORING NO. B-10
 North Campus Housing
 California State University
 Monterey Bay





ELEVATION, ft	DEPTH, ft	MATERIAL SYMBOL	SAMPLE NO.	SAMPLES	BLOW COUNT / REC'D/DRIVE"	LOCATION: The drill hole location referencing local landmarks or coordinates SURFACE EL: Using local, MSL, MLLW or other datum	General Notes
MATERIAL DESCRIPTION							
-12	2		1		25	Well graded GRAVEL (GW)	COARSE GRAINED SOIL TEXTURE SYMBOL Sloped line in symbol column indicates transitional boundary SAMPLERS AND SAMPLER DIMENSIONS (unless otherwise noted in report text) are as follows: Symbol for: 1 SPT Sampler, driven 1-3/8" ID, 2" OD 2 CA Liner Sampler, driven 2-3/8" ID, 3" OD 3 CA Liner Sampler, disturbed 2-3/8" ID, 3" OD 4 Thin-walled Tube, pushed 2-7/8" ID, 3" OD 5 Bulk Bag Sample (from cuttings) 6 CA Liner Sampler, Bagged 7 Hand Auger Sample 8 CME Core Sample 9 Pitcher Sample 10 Lexan Sample 11 Vibracore Sample 12 No Sample Recovered 13 Sonic Soil Core Sample SAMPLER DRIVING RESISTANCE Number of blows with 140 lb. hammer, falling 30" to drive sampler 1 ft. after seating sampler 6"; for example, Blows/ft Description 25 25 blows drove sampler 12" after initial 6" of seating 86/11" After driving sampler the initial 6" of seating, 36 blows drove sampler through the second 6" interval, and 50 blows drove the sampler 5" into the third interval 50/6" 50 blows drove sampler 6" after initial 6" of seating Ref/3" 50 blows drove sampler 3" during initial 6" seating interval Blow counts for California Liner Sampler shown in () Length of sample symbol approximates recovery length Classification of Soils per ASTM D2487 or D2488 Geologic Formation noted in bold font at the top of interpreted interval STRENGTH LEGEND Q = Unconfined Compression u = Unconsolidated Undrained Triaxial t = Torvane p = Pocket Penetrometer m = Miniature Vane WATER LEVEL SYMBOLS Initial or perched water level Final ground water level Seepages encountered Rock Quality Designation (RQD) is the sum of recovered core pieces greater than 4 inches divided by the length of the cored interval.
-14	4		2		(25)	Poorly graded GRAVEL (GP)	
-16	6		3		(25)	Well graded SAND (SW)	
-18	8		4		(25)	Poorly graded SAND (SP)	
-20	10		5		(25)	Silty SAND (SM)	
-22	12		6		18"/30"	Clayey SAND (SC)	
-24	14		7		(25)	Silty, Clayey SAND (SC-SM)	
-26	16		8		(25)	Elastic SILT (MH)	
-28	18		9		(25)	SILT (ML)	
-30	20		10		20"/24"	Silty CLAY (CL-ML)	
-32	22		11		(25)	Fat CLAY (CH)	
-34	24		12		(25)	Lean CLAY (CL)	
-36	26		13		30"/30"	CONGLOMERATE	
-38	28				20"/24"	SANDSTONE	
-40	30					SILTSTONE	
-42	32					MUDSTONE	
-44	34					CLAYSTONE	
-46	36					SHALE	
-48	38					IGNEOUS	
						Paving and/or Base Materials	

KEY TO TERMS & SYMBOLS USED ON LOGS



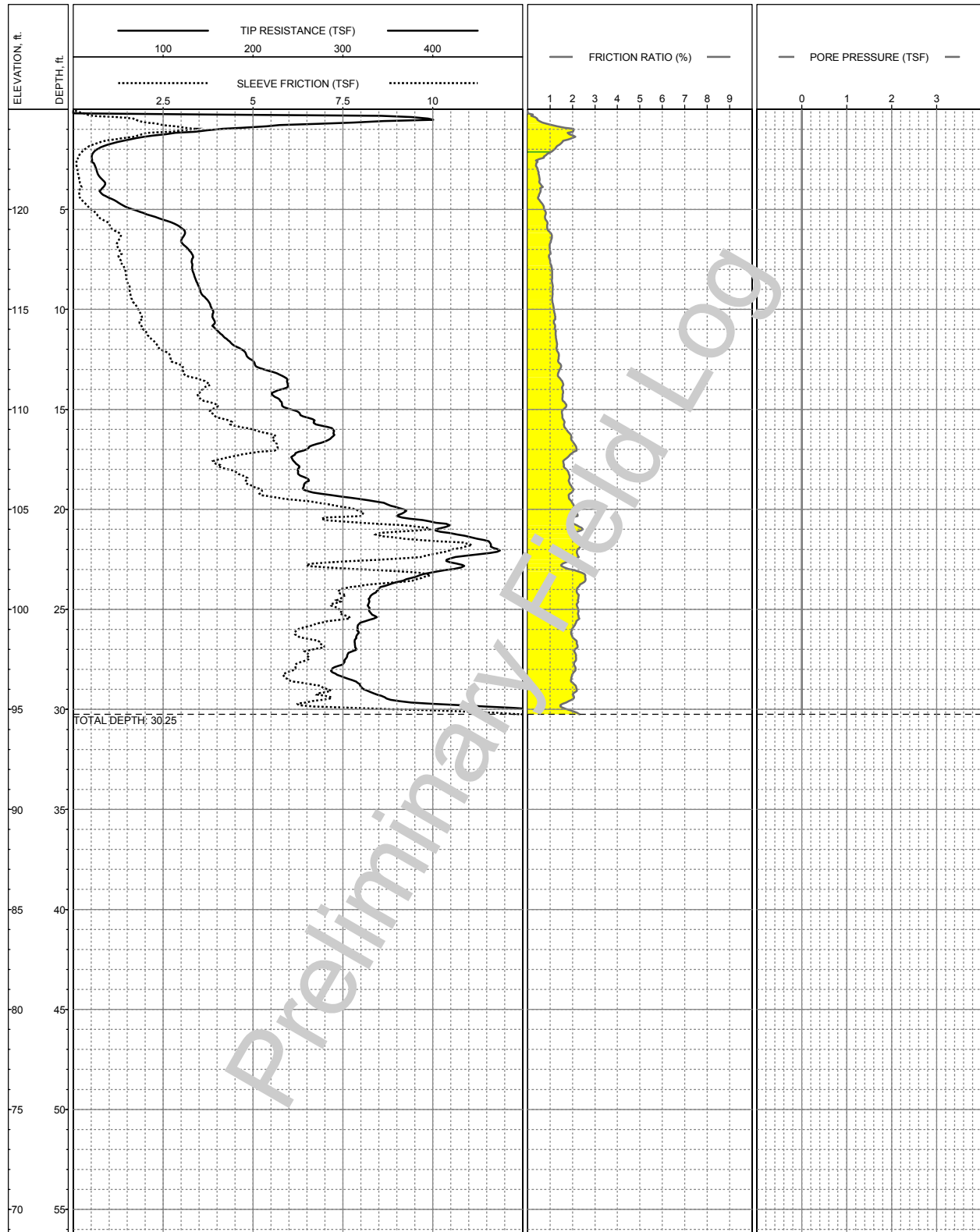

LOCATION: E5738192.63 N2135235.21 (Stateplane, CA Z4, NAD 83, Feet)
 SURFACE EL: 125ft +/- (MSL)
 COMPLETION DEPTH: 30.25ft
 TESTDATE: 3/2/2004

EXPLORATION METHOD: Cone Penetrometer
 PERFORMED BY: Fugro Geosciences
 REVIEWED BY: C A Wockner

LOG OF CPT-1
 North Campus Housing
 California State University
 Monterey Bay

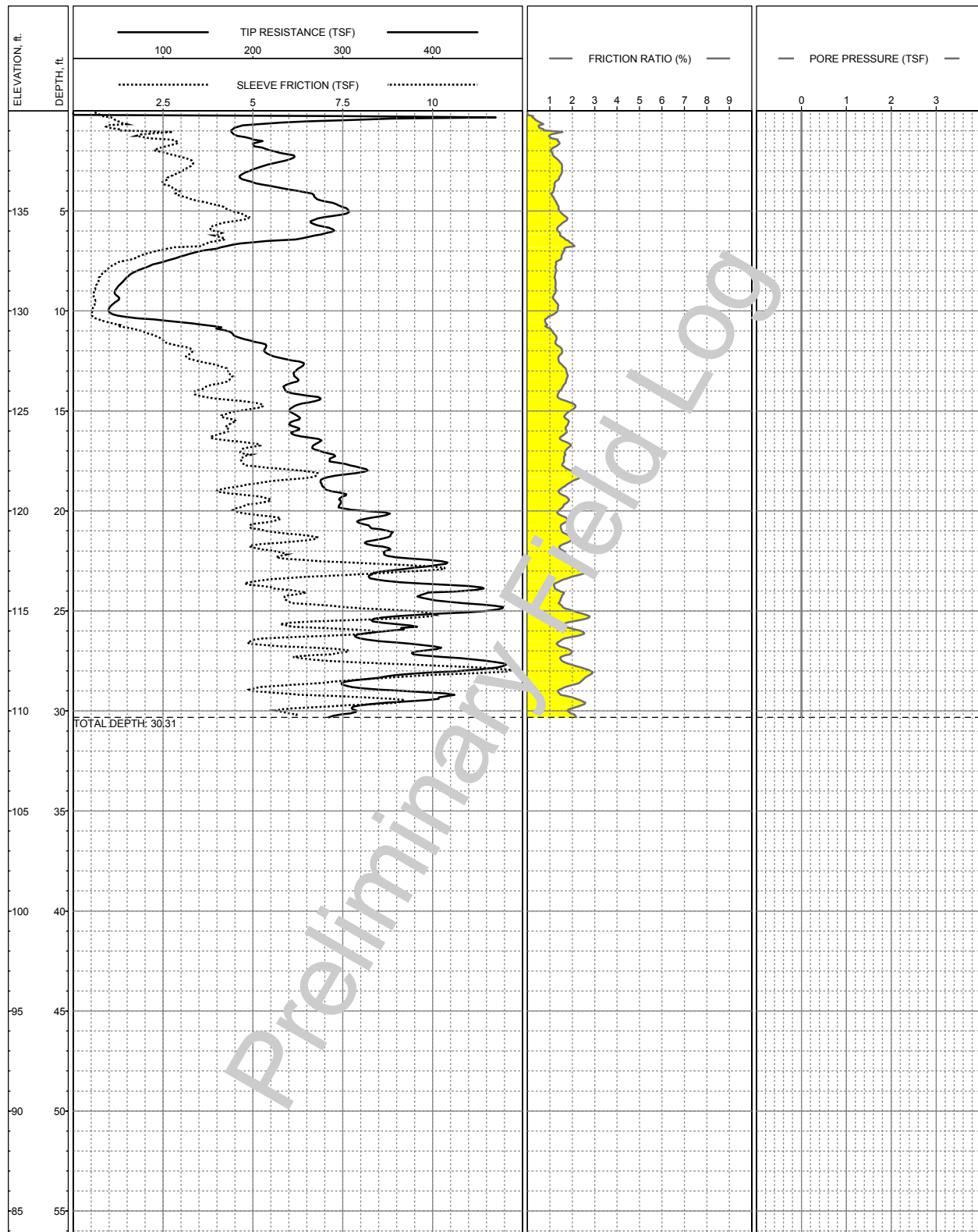

LOCATION: E5738176.92 N2134865.39 (Stateplane, CA Z4, NAD 83, Feet)
 SURFACE EL: 140ft +/- (MSL)
 COMPLETION DEPTH: 30.31ft
 TESTDATE: 3/2/2004

EXPLORATION METHOD: Cone Penetrometer
 PERFORMED BY: Fugro Geosciences
 REVIEWED BY: C A Wockner

LOG OF CPT-2
 North Campus Housing
 California State University
 Monterey Bay

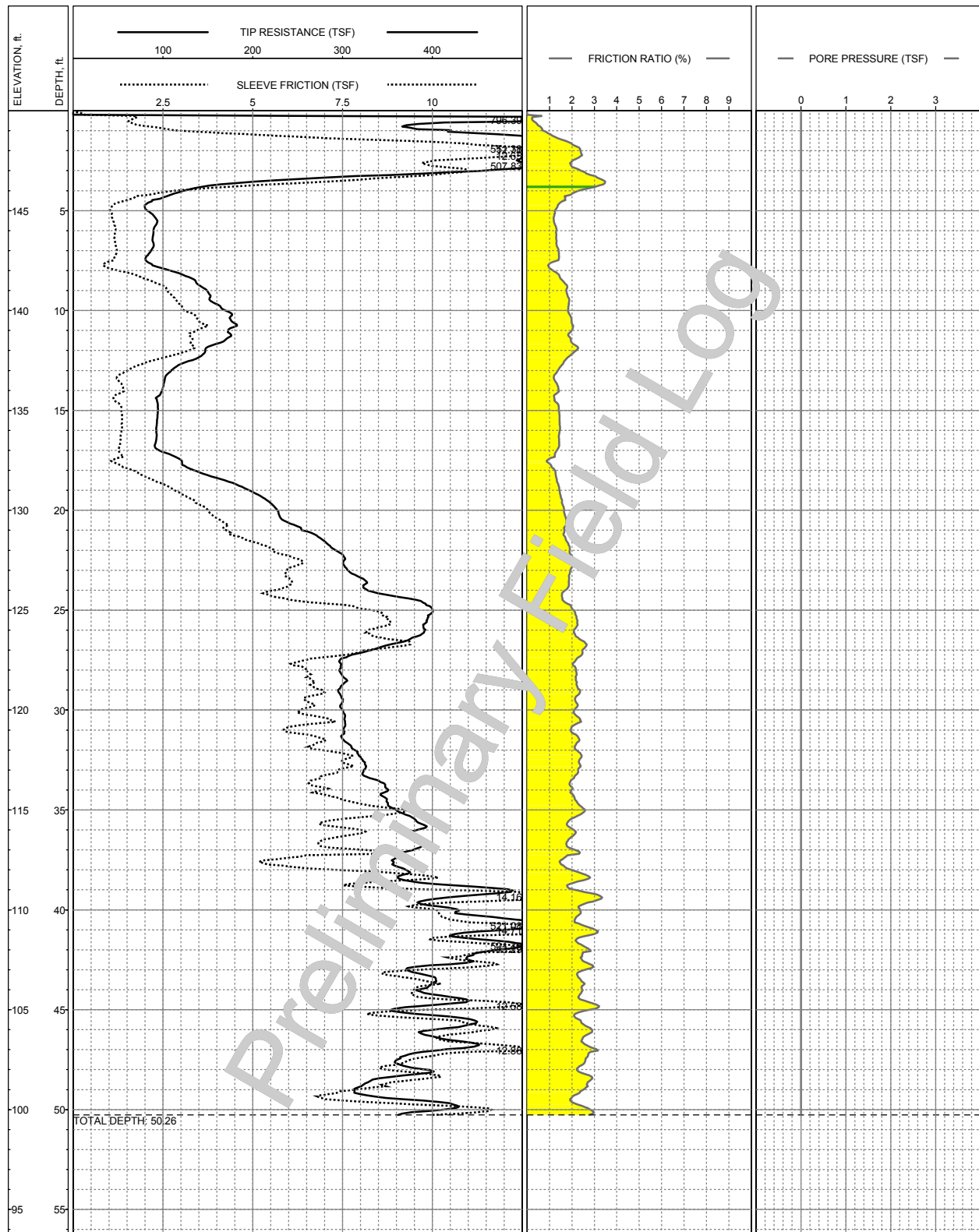

LOCATION: E5738064.64 N2134370.91 (Stateplane, CA Z4, NAD 83, Feet)
 SURFACE EL: 150ft +/- (MSL)
 COMPLETION DEPTH: 50.26ft
 TESTDATE: 3/2/2004

EXPLORATION METHOD: Cone Penetrometer
 PERFORMED BY: Fugro Geosciences
 REVIEWED BY: C A Wockner

LOG OF CPT-3
 North Campus Housing
 California State University
 Monterey Bay

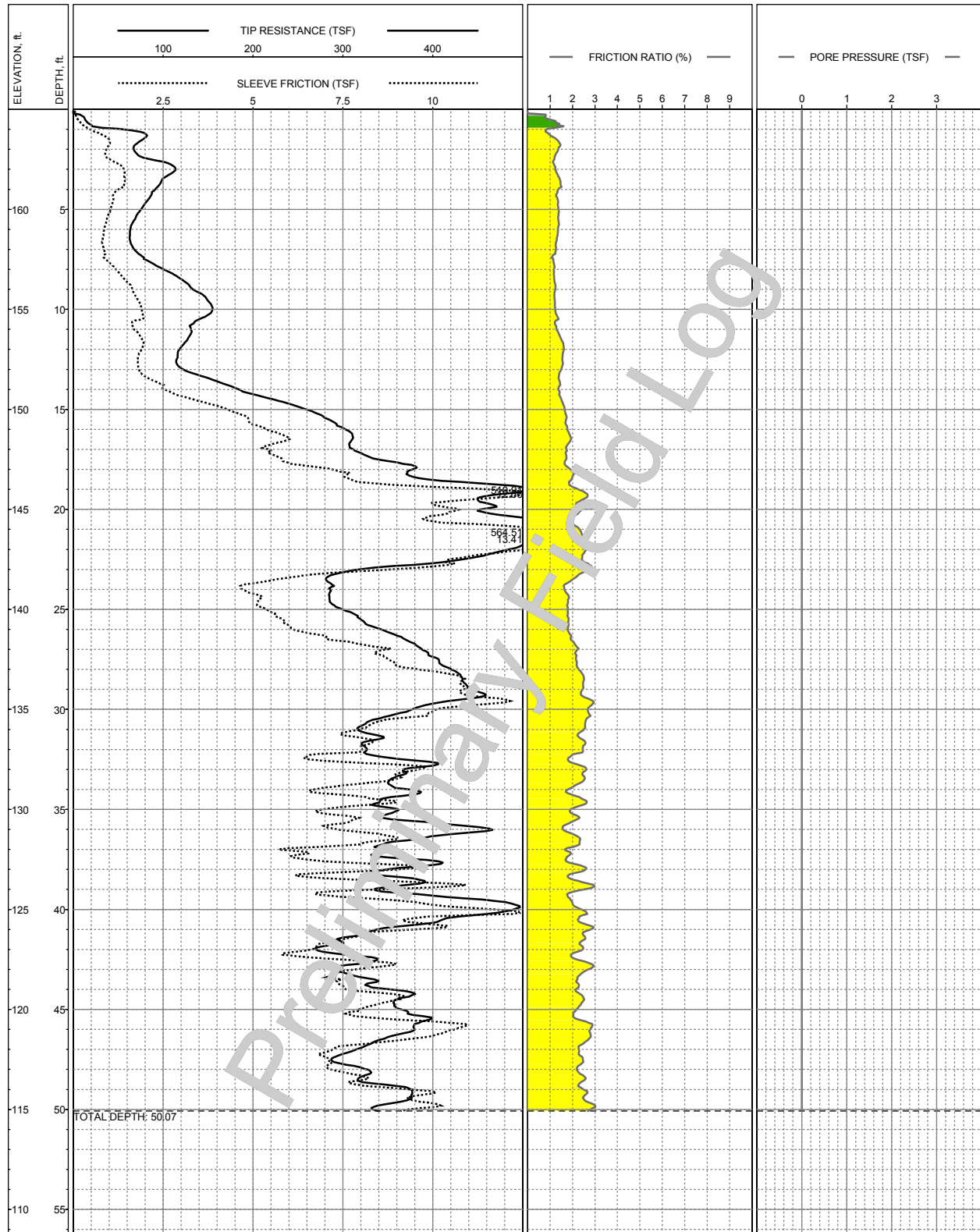

LOCATION: E5737944.36 N2133939.34 (Stateplane, CA Z4, NAD 83, Feet)
 SURFACE EL: 165ft +/- (MSL)
 COMPLETION DEPTH: 50.07ft
 TESTDATE: 3/2/2004

EXPLORATION METHOD: Cone Penetrometer
 PERFORMED BY: Fugro Geosciences
 REVIEWED BY: C A Wockner

LOG OF CPT-4
 North Campus Housing
 California State University
 Monterey Bay

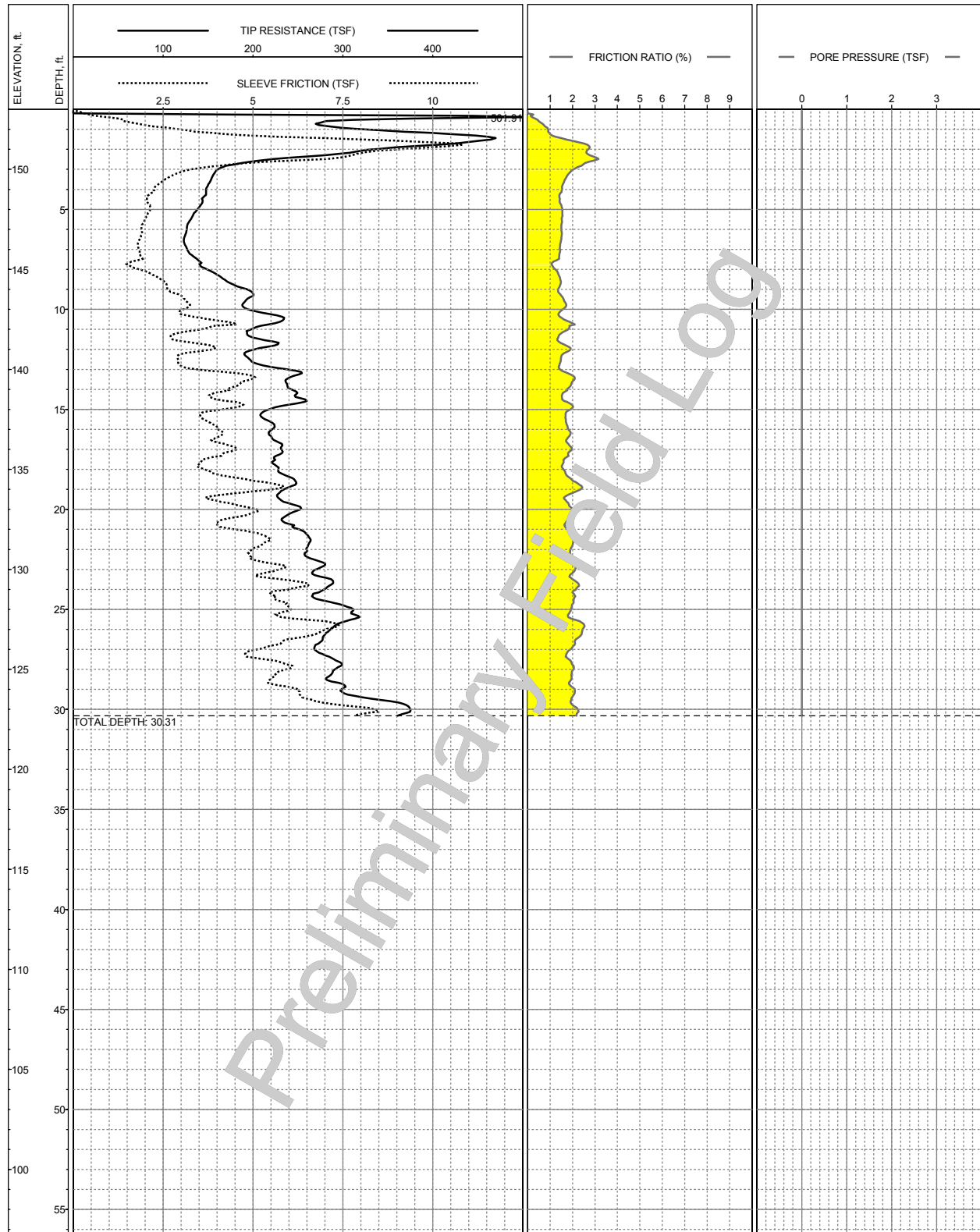

LOCATION: E5738418.78 N2134439.47 (Stateplane, CA Z4, NAD 83, Feet)
 SURFACE EL: 153ft +/- (MSL)
 COMPLETION DEPTH: 30.31ft
 TESTDATE: 3/2/2004

EXPLORATION METHOD: Cone Penetrometer
 PERFORMED BY: Fugro Geosciences
 REVIEWED BY: C A Wockner

LOG OF CPT-5
 North Campus Housing
 California State University
 Monterey Bay

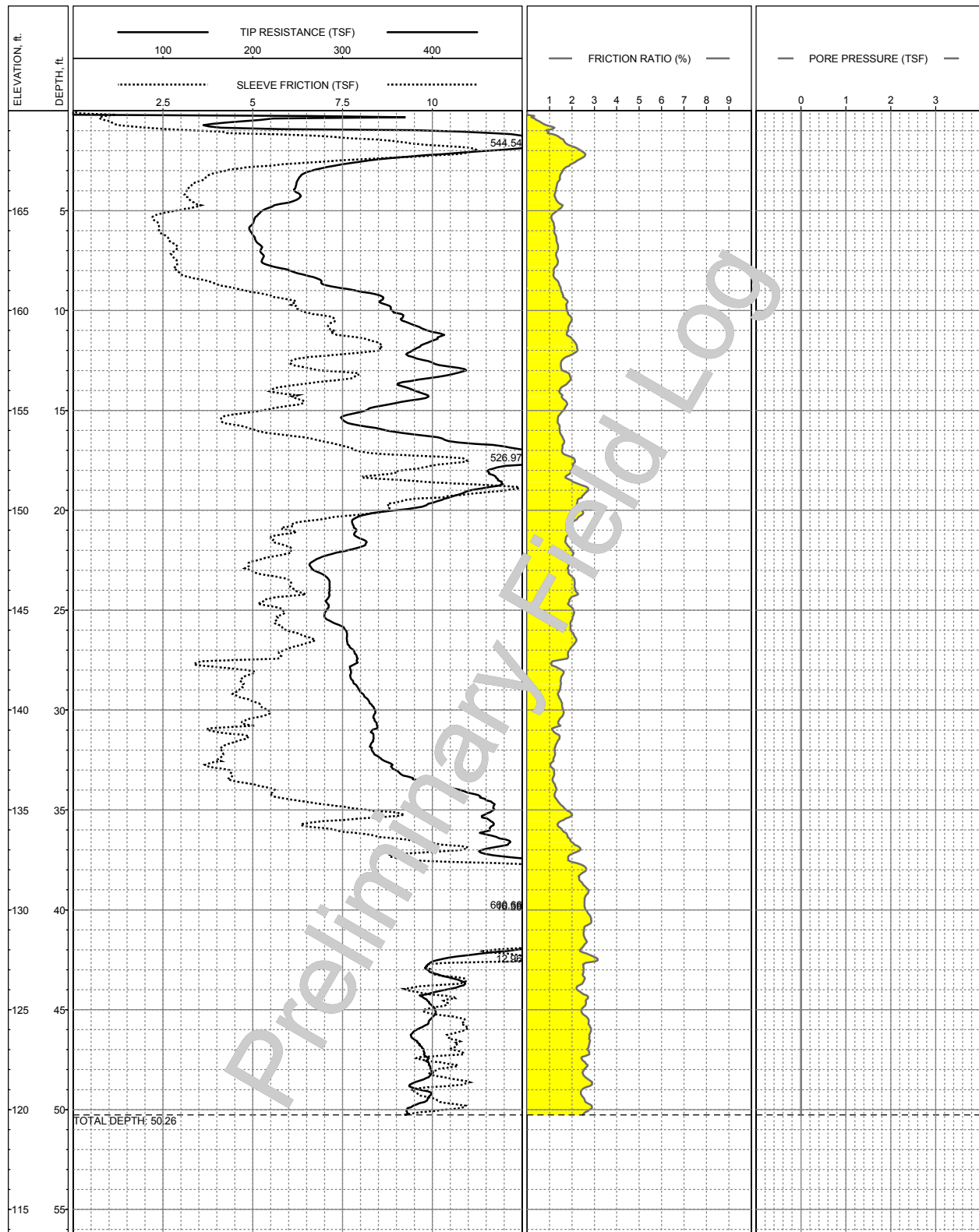

LOCATION: E5739565.89 N2134363.46 (Stateplane, CA Z4, NAD 83, Feet)
 SURFACE EL: 170ft +/- (MSL)
 COMPLETION DEPTH: 50.26ft
 TESTDATE: 3/2/2004

EXPLORATION METHOD: Cone Penetrometer
 PERFORMED BY: Fugro Geosciences
 REVIEWED BY: C A Wockner

LOG OF CPT-6
 North Campus Housing
 California State University
 Monterey Bay

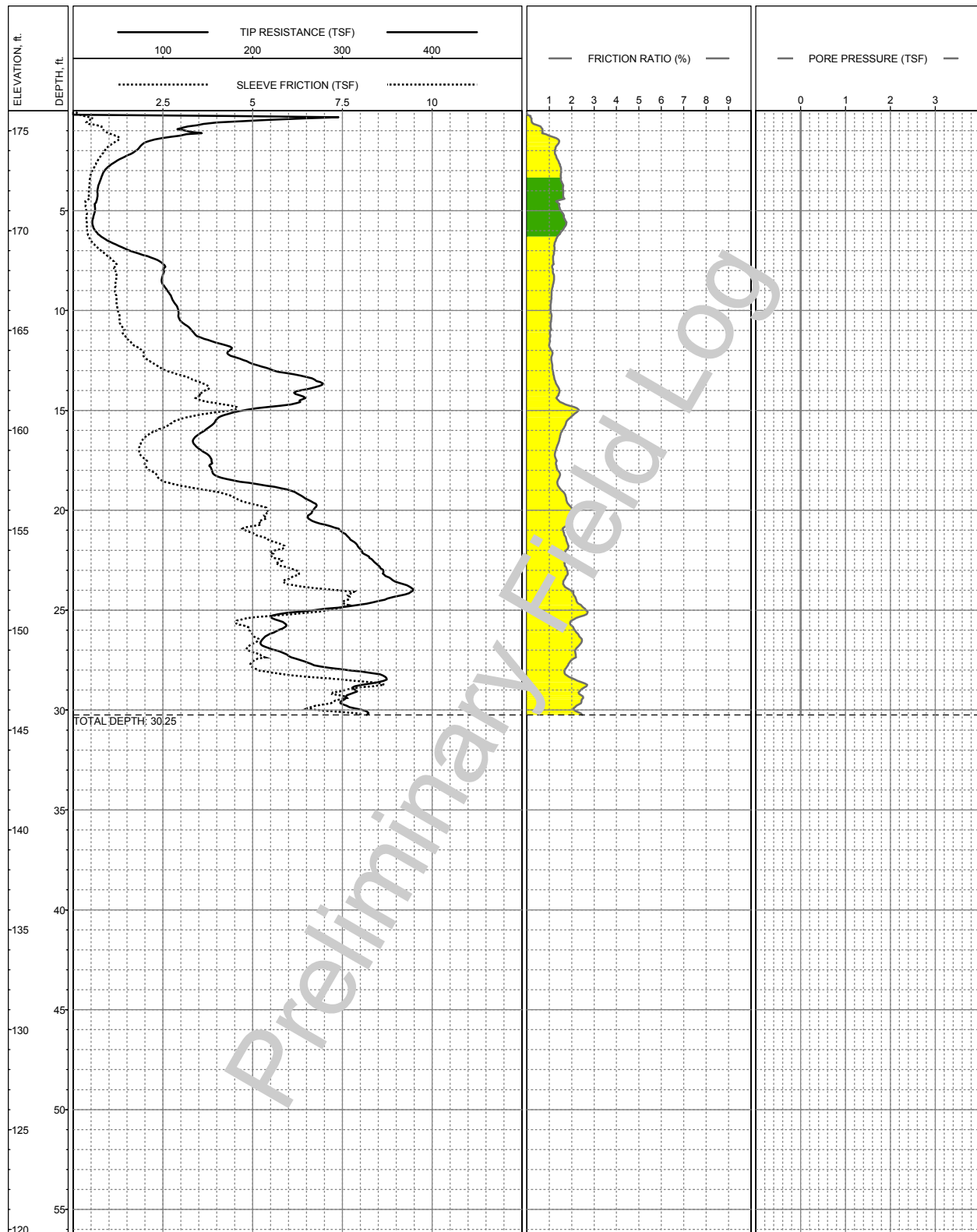

LOCATION: E5739804.06 N2134380.36 (Stateplane, CA Z4, NAD 83, Feet)
 SURFACE EL: 176ft +/- (MSL)
 COMPLETION DEPTH: 30.25ft
 TESTDATE: 3/2/2004

EXPLORATION METHOD: Cone Penetrometer
 PERFORMED BY: Fugro Geosciences
 REVIEWED BY: C A Wockner

LOG OF CPT-7
 North Campus Housing
 California State University
 Monterey Bay

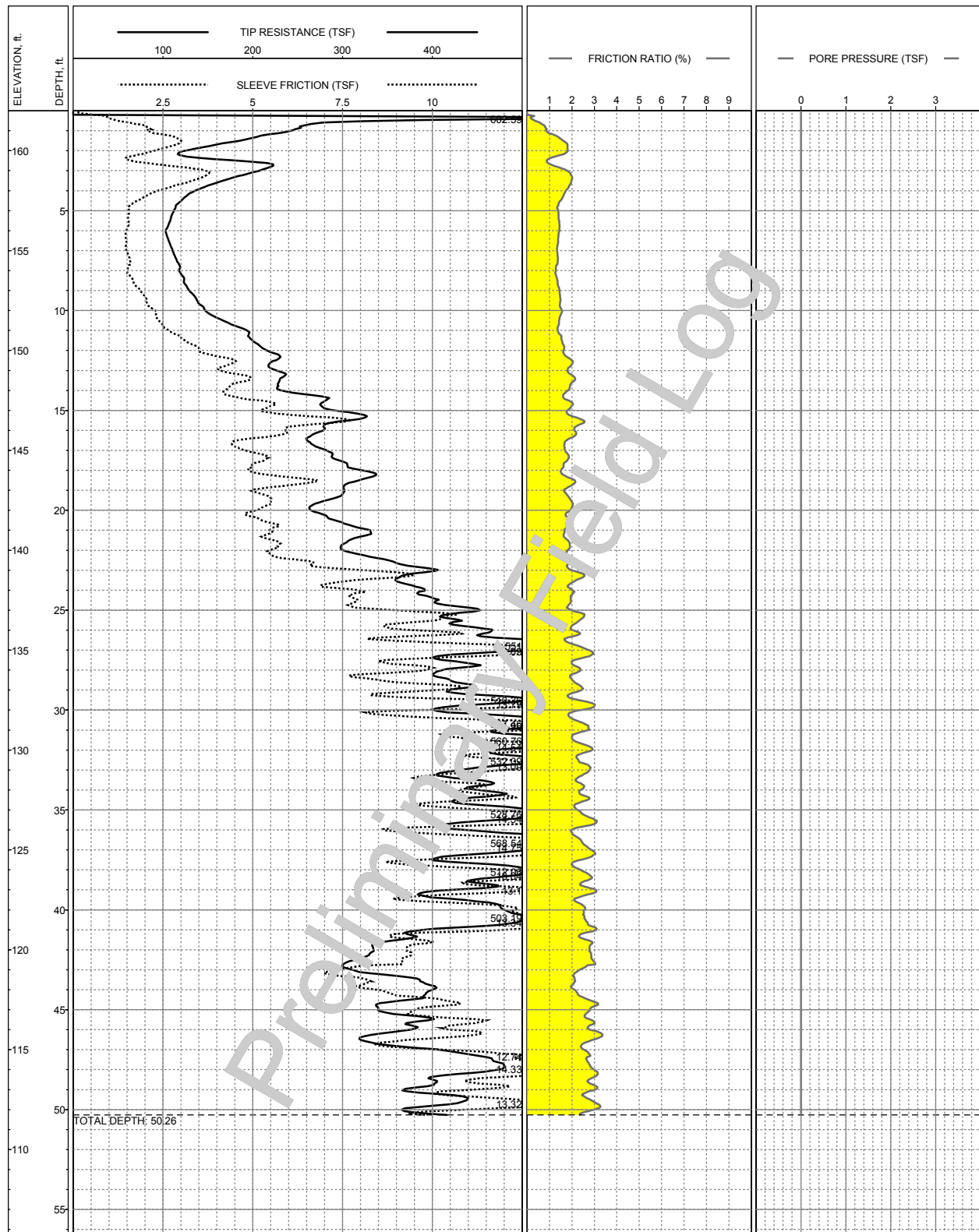

LOCATION: E5740717.76 N2134451.26 (Stateplane, CA Z4, NAD 83, Feet)
 SURFACE EL: 162ft +/- (MSL)
 COMPLETION DEPTH: 50.26ft
 TESTDATE: 3/2/2004

EXPLORATION METHOD: Cone Penetrometer
 PERFORMED BY: Fugro Geosciences
 REVIEWED BY: C A Wockner

LOG OF CPT-8
 North Campus Housing
 California State University
 Monterey Bay

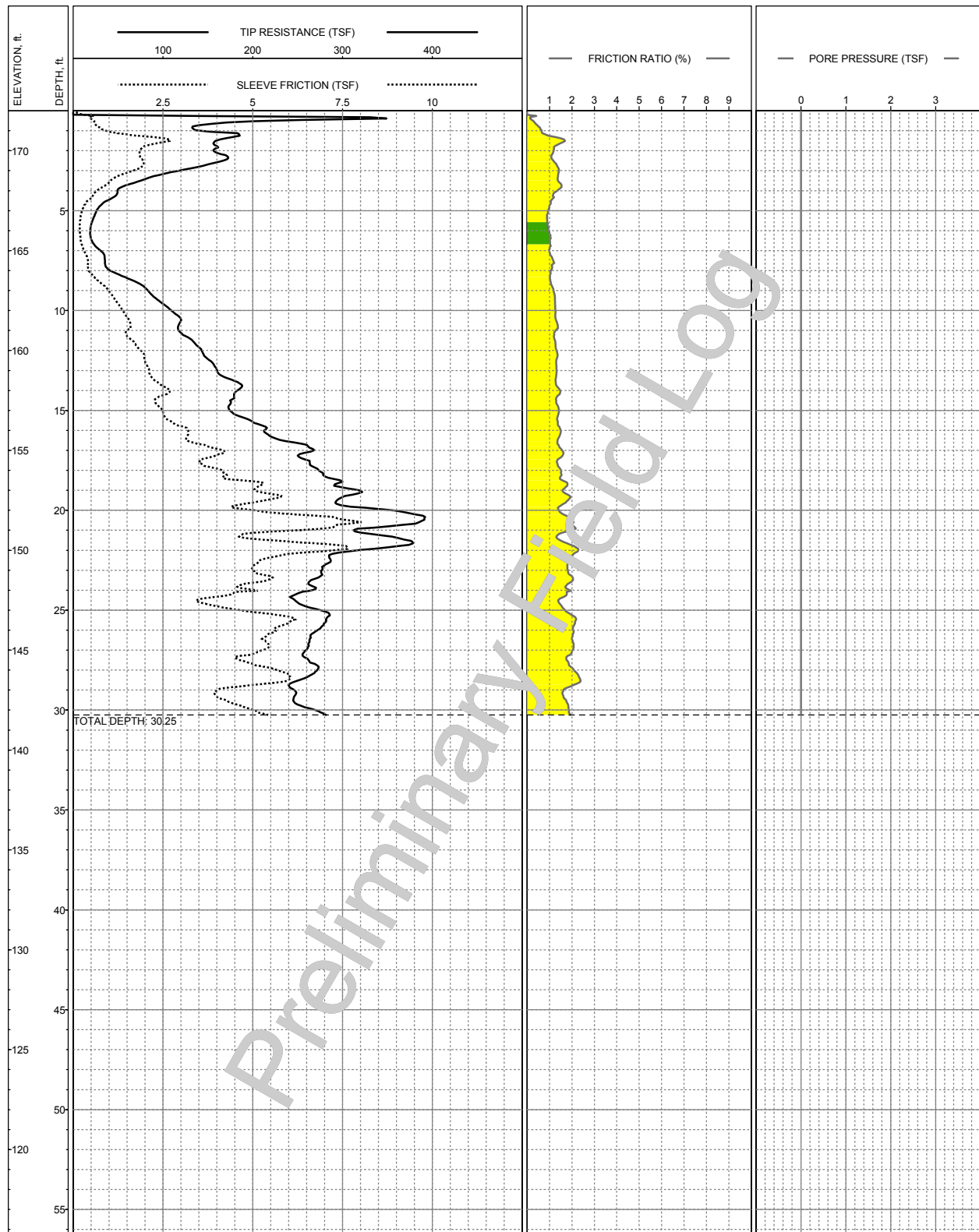

LOCATION: E5739804.77 N2134672.14 (Stateplane, CA Z4, NAD 83, Feet)
 SURFACE EL: 172ft +/- (MSL)
 COMPLETION DEPTH: 30.25ft
 TESTDATE: 3/2/2004

EXPLORATION METHOD: Cone Penetrometer
 PERFORMED BY: Fugro Geosciences
 REVIEWED BY: C A Wockner

LOG OF CPT-9
 North Campus Housing
 California State University
 Monterey Bay

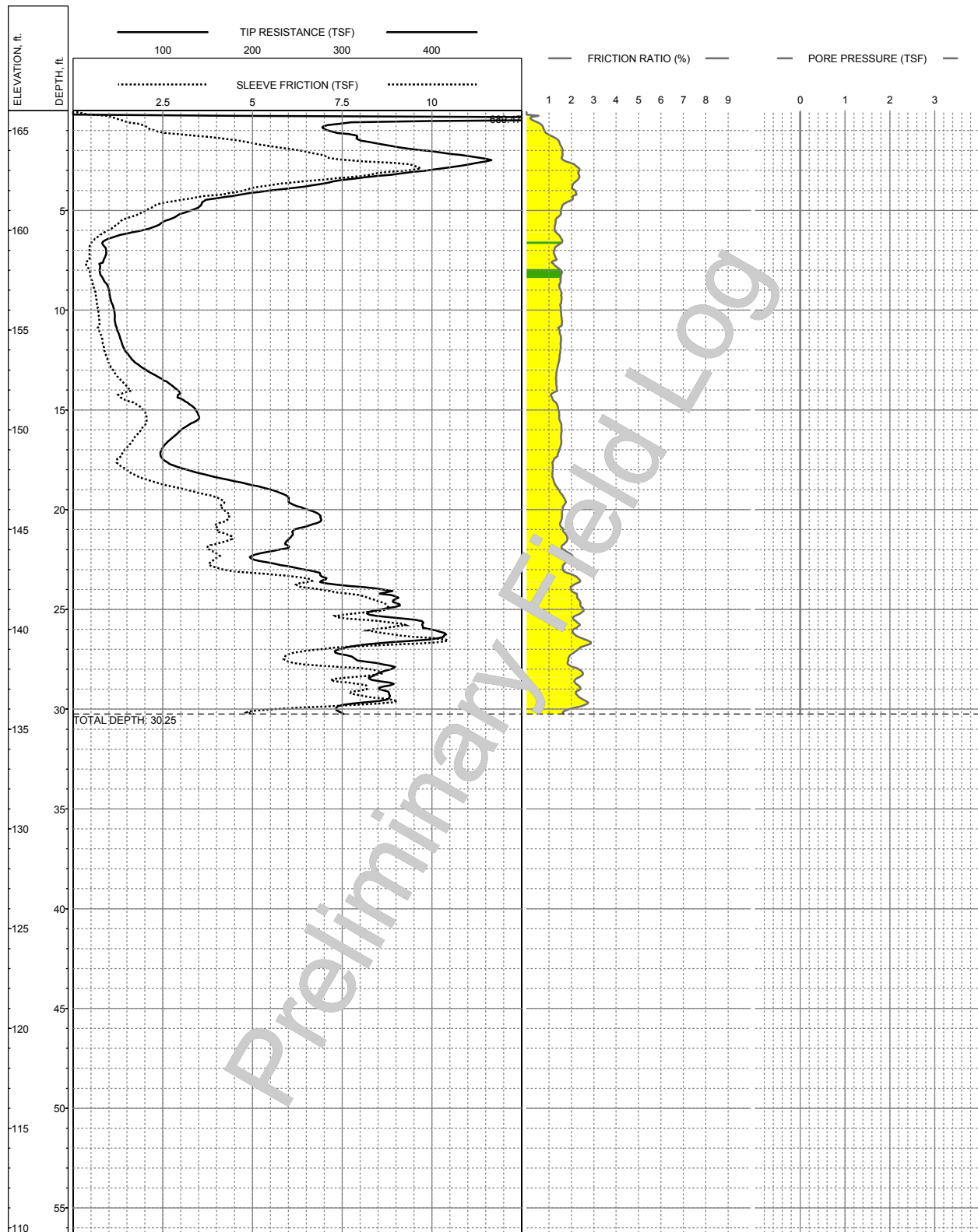

LOCATION: E5740266.87 N2134585.82 (Stateplane, CA Z4, NAD 83, Feet)
 SURFACE EL: 166ft +/- (MSL)
 COMPLETION DEPTH: 30.25ft
 TESTDATE: 3/2/2004

EXPLORATION METHOD: Cone Penetrometer
 PERFORMED BY: Fugro Geosciences
 REVIEWED BY: C A Wockner

LOG OF CPT-10
 North Campus Housing
 California State University
 Monterey Bay

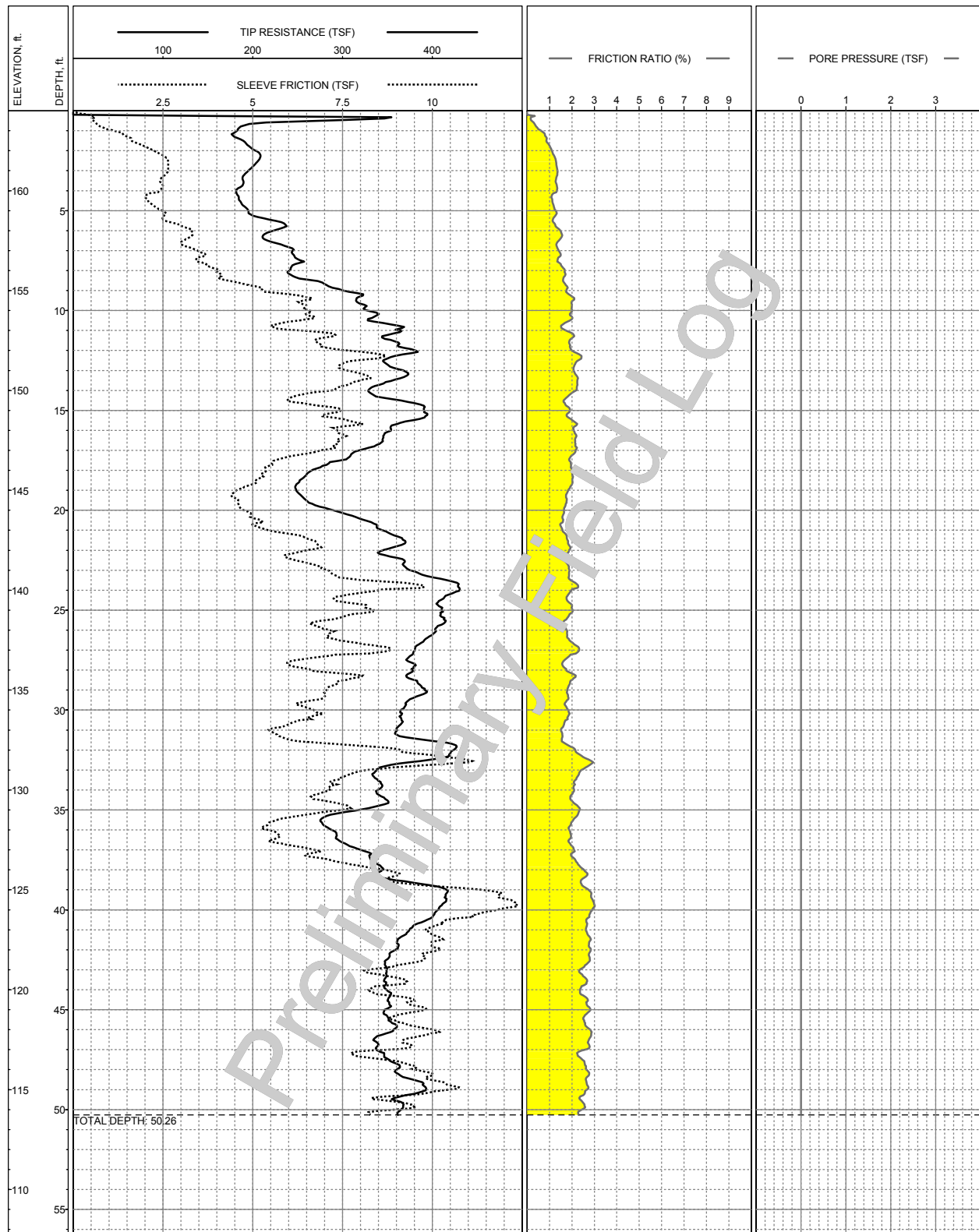

LOCATION: E5740249.76 N2135005.16 (Stateplane, CA Z4, NAD 83, Feet)
 SURFACE EL: 164ft +/- (MSL)
 COMPLETION DEPTH: 50.26ft
 TESTDATE: 3/2/2004

EXPLORATION METHOD: Cone Penetrometer
 PERFORMED BY: Fugro Geosciences
 REVIEWED BY: C A Wockner

LOG OF CPT-11
 North Campus Housing
 California State University
 Monterey Bay

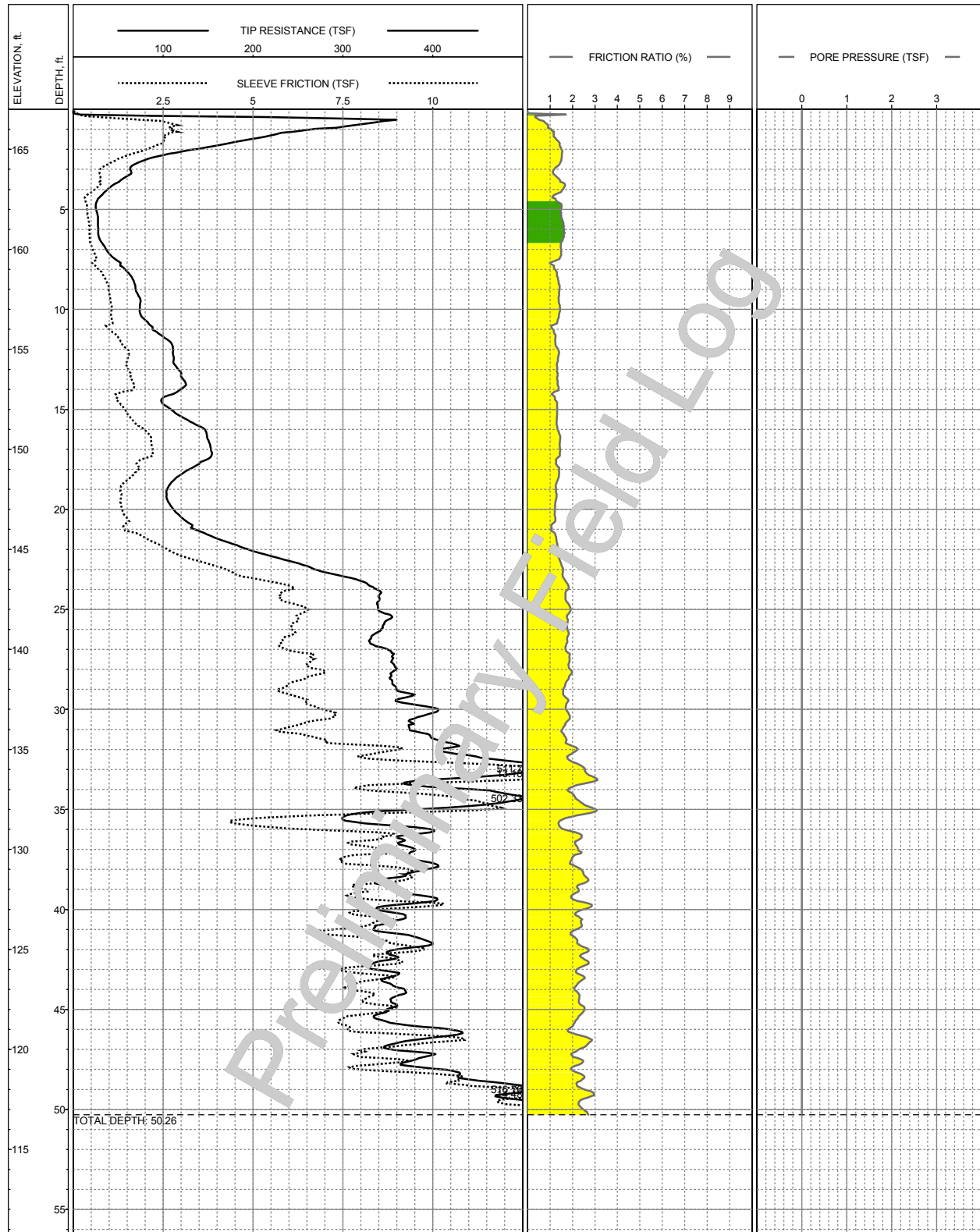

LOCATION: E5739614.44 N2135691.42 (Stateplane, CA Z4, NAD 83, Feet)
 SURFACE EL: 167ft +/- (MSL)
 COMPLETION DEPTH: 50.26ft
 TESTDATE: 3/2/2004

EXPLORATION METHOD: Cone Penetrometer
 PERFORMED BY: Fugro Geosciences
 REVIEWED BY: C A Wockner

LOG OF CPT-12
 North Campus Housing
 California State University
 Monterey Bay

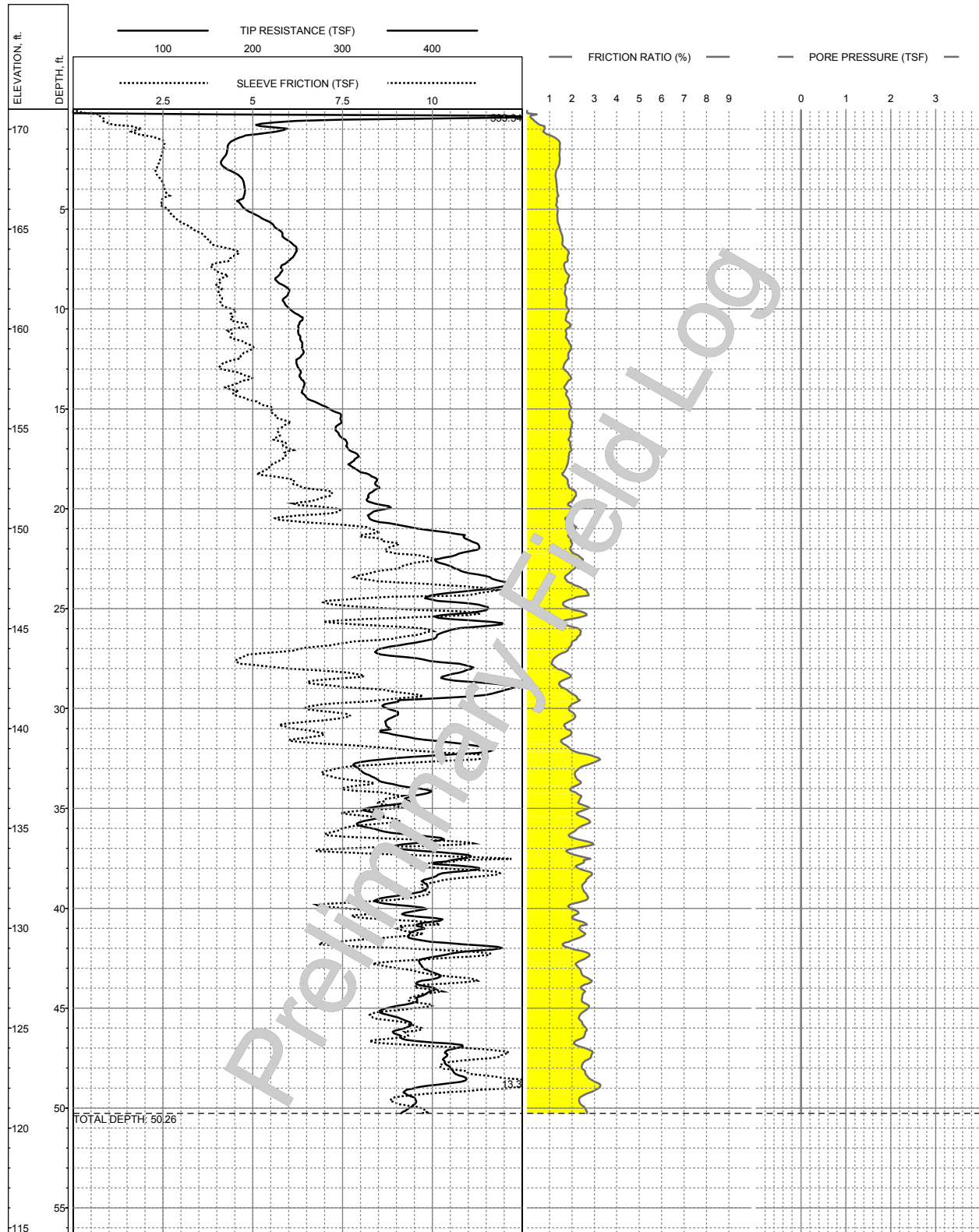

LOCATION: E5739839.43 N2135357.06 (Stateplane, CA Z4, NAD 83, Feet)
 SURFACE EL: 171ft +/- (MSL)
 COMPLETION DEPTH: 50.26ft
 TESTDATE: 3/2/2004

EXPLORATION METHOD: Cone Penetrometer
 PERFORMED BY: Fugro Geosciences
 REVIEWED BY: C A Wockner

LOG OF CPT-13
 North Campus Housing
 California State University
 Monterey Bay

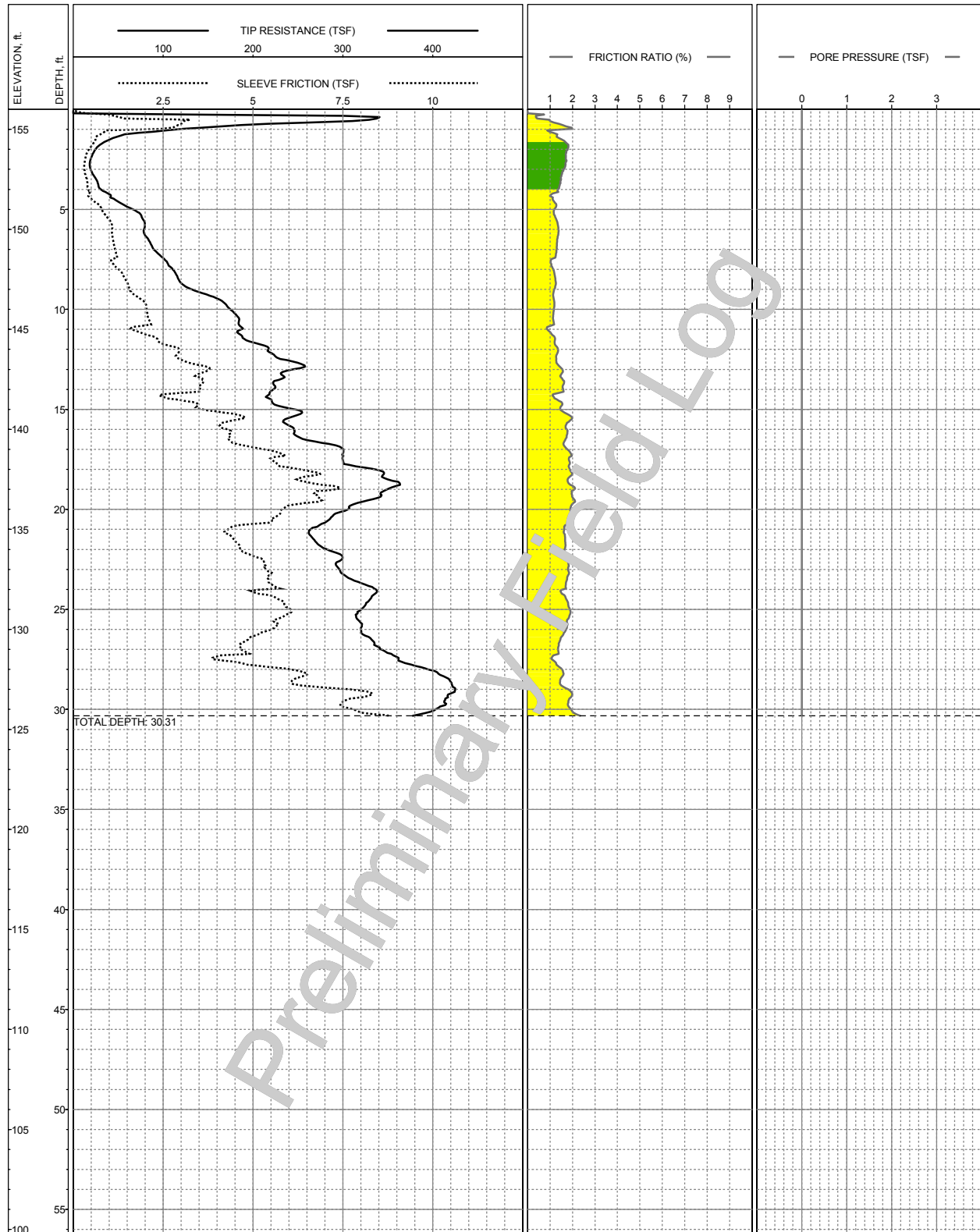

LOCATION: E5739059.68 N2134948.85 (Stateplane, CA Z4, NAD 83, Feet)
 SURFACE EL: 156ft +/- (MSL)
 COMPLETION DEPTH: 30.31ft
 TESTDATE: 3/2/2004

EXPLORATION METHOD: Cone Penetrometer
 PERFORMED BY: Fugro Geosciences
 REVIEWED BY: C A Wockner

LOG OF CPT-14
 North Campus Housing
 California State University
 Monterey Bay

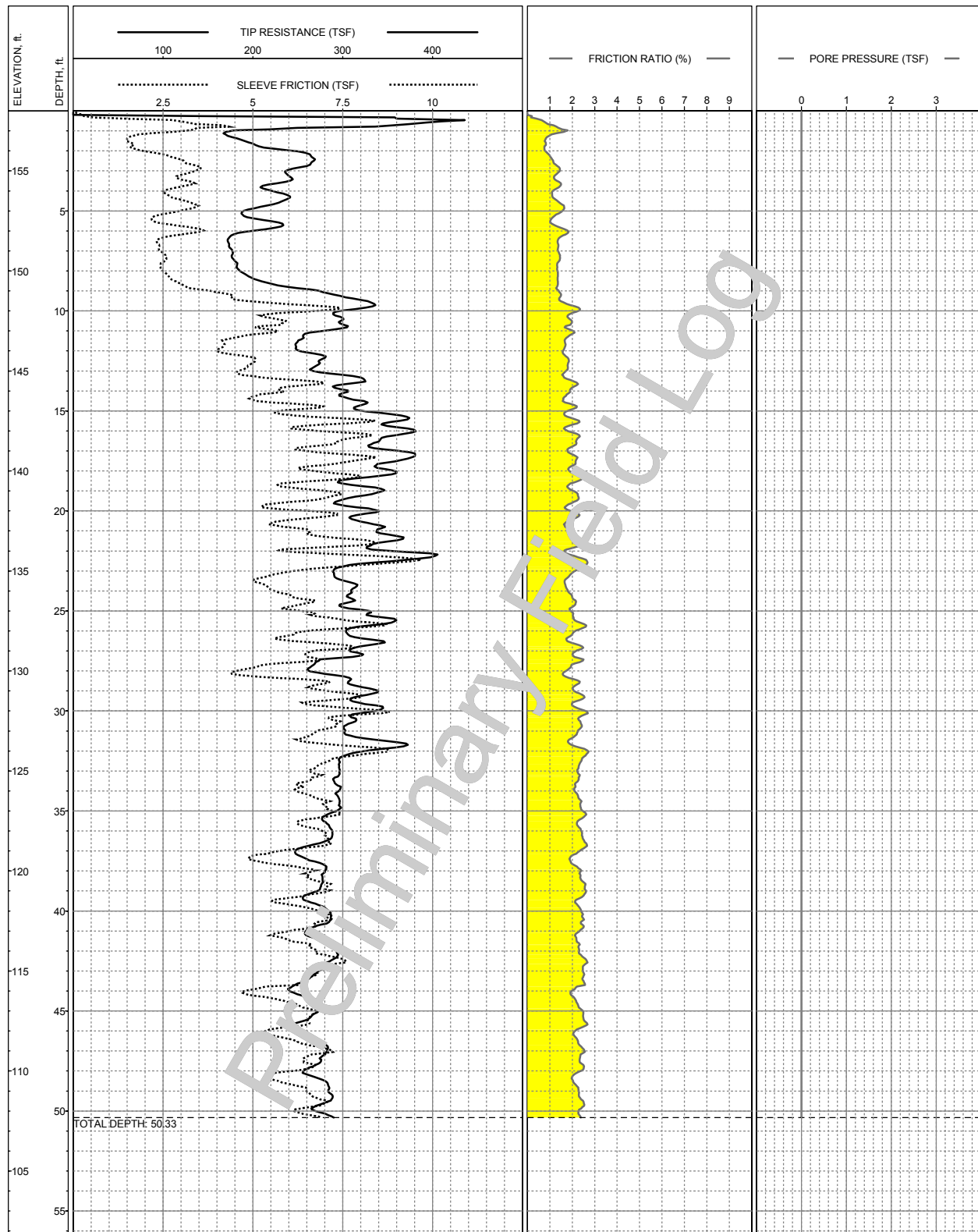

LOCATION: E5738886.63 N2134717.17 (Stateplane, CA Z4, NAD 83, Feet)
 SURFACE EL: 158ft +/- (MSL)
 COMPLETION DEPTH: 50.33ft
 TESTDATE: 3/2/2004

EXPLORATION METHOD: Cone Penetrometer
 PERFORMED BY: Fugro Geosciences
 REVIEWED BY: C A Wockner

LOG OF CPT-15
 North Campus Housing
 California State University
 Monterey Bay

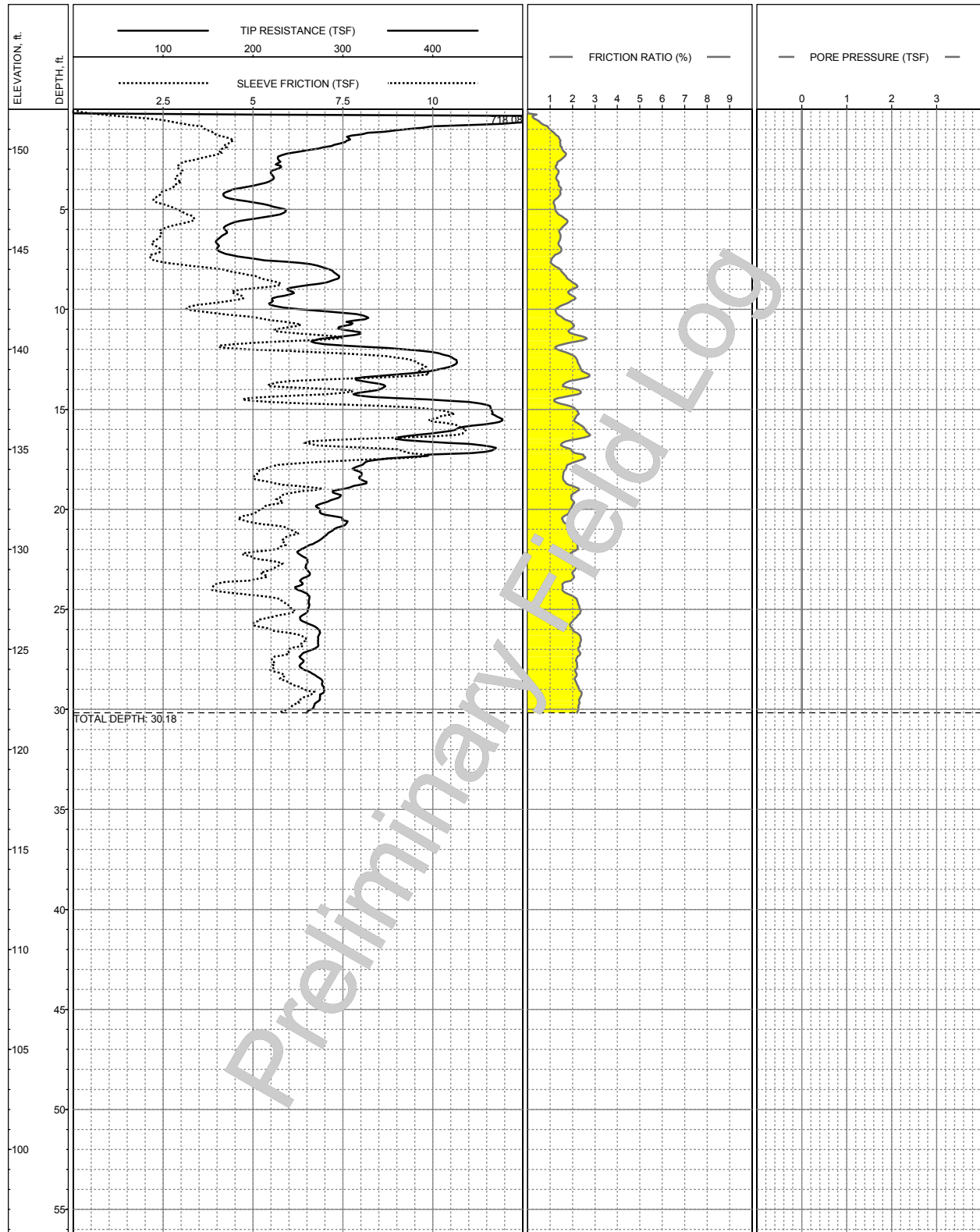

LOCATION: E5738598.86 N2134743.79 (Stateplane, CA Z4, NAD 83, Feet)
 SURFACE EL: 152ft +/- (MSL)
 COMPLETION DEPTH: 30.18ft
 TESTDATE: 3/2/2004

EXPLORATION METHOD: Cone Penetrometer
 PERFORMED BY: Fugro Geosciences
 REVIEWED BY: C A Wockner

LOG OF CPT-16
 North Campus Housing
 California State University
 Monterey Bay

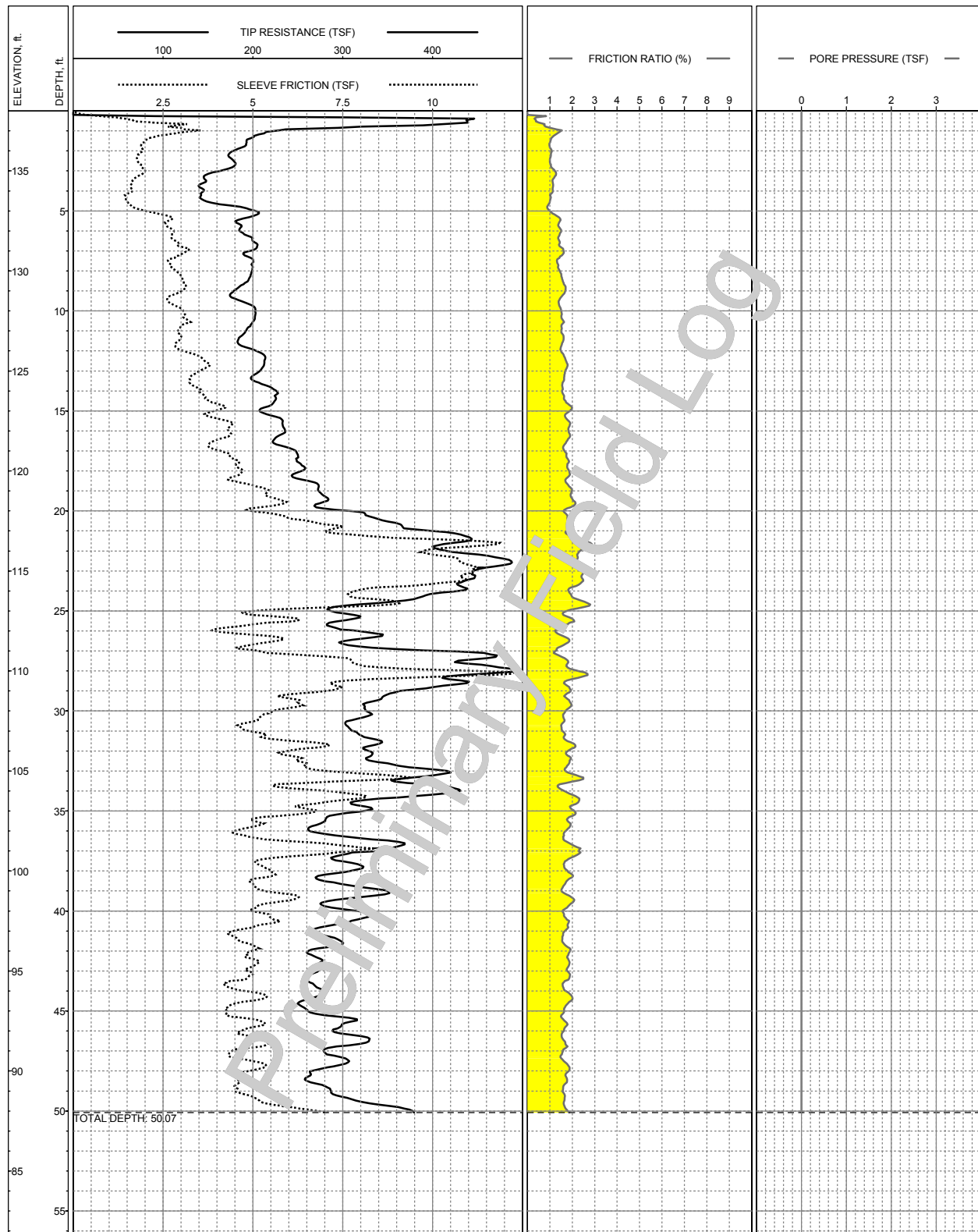

LOCATION: E5738571.46 N2135145.22 (Stateplane, CA Z4, NAD 83, Feet)
 SURFACE EL: 138ft +/- (MSL)
 COMPLETION DEPTH: 50.07ft
 TESTDATE: 3/2/2004

EXPLORATION METHOD: Cone Penetrometer
 PERFORMED BY: Fugro Geosciences
 REVIEWED BY: C A Wockner

LOG OF CPT-17
 North Campus Housing
 California State University
 Monterey Bay

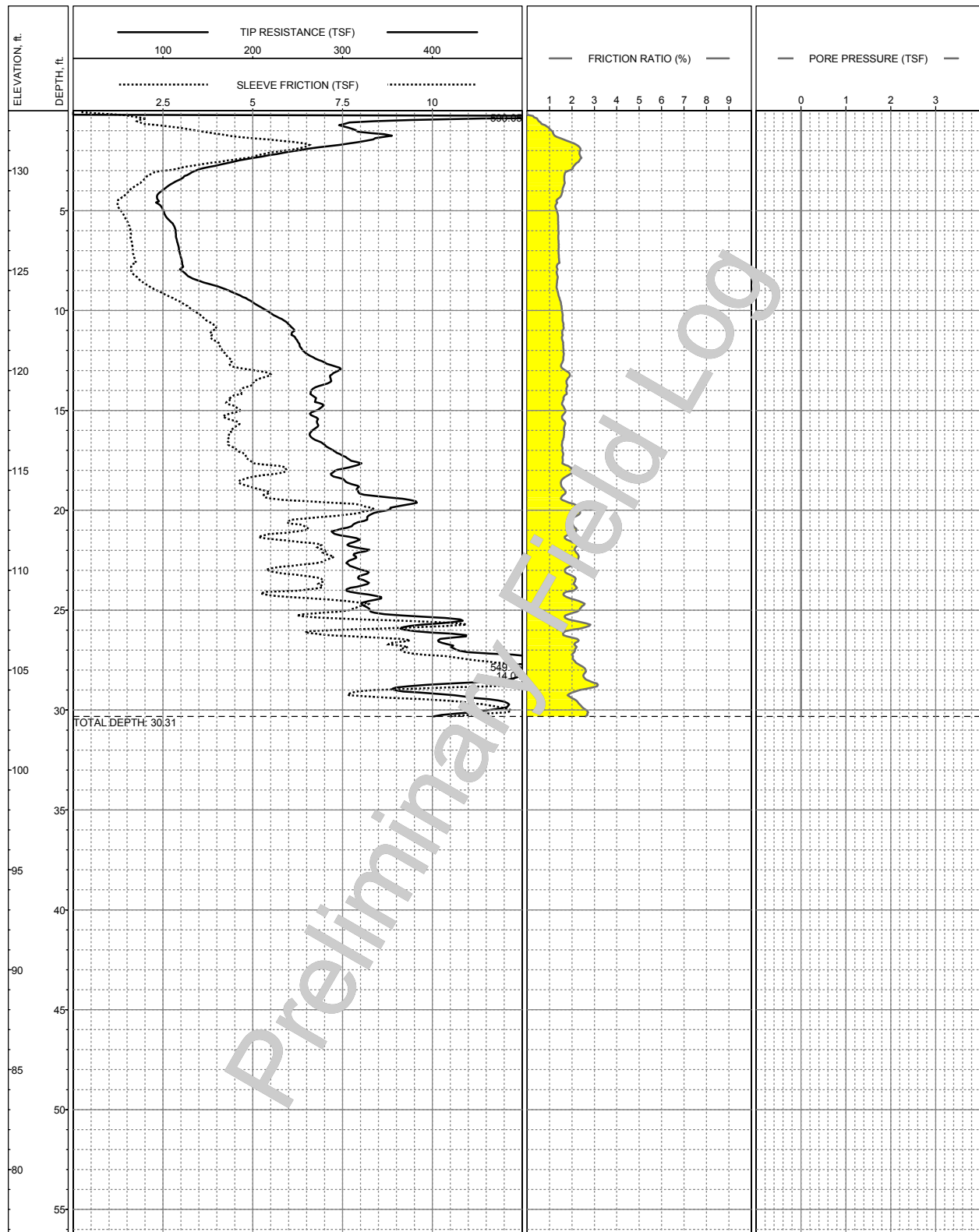

LOCATION: E5738676.01 N2135542.8 (Stateplane, CA Z4, NAD 83, Feet)
 SURFACE EL: 133ft +/- (MSL)
 COMPLETION DEPTH: 30.31ft
 TESTDATE: 3/2/2004

EXPLORATION METHOD: Cone Penetrometer
 PERFORMED BY: Fugro Geosciences
 REVIEWED BY: C A Wockner

LOG OF CPT-18
 North Campus Housing
 California State University
 Monterey Bay

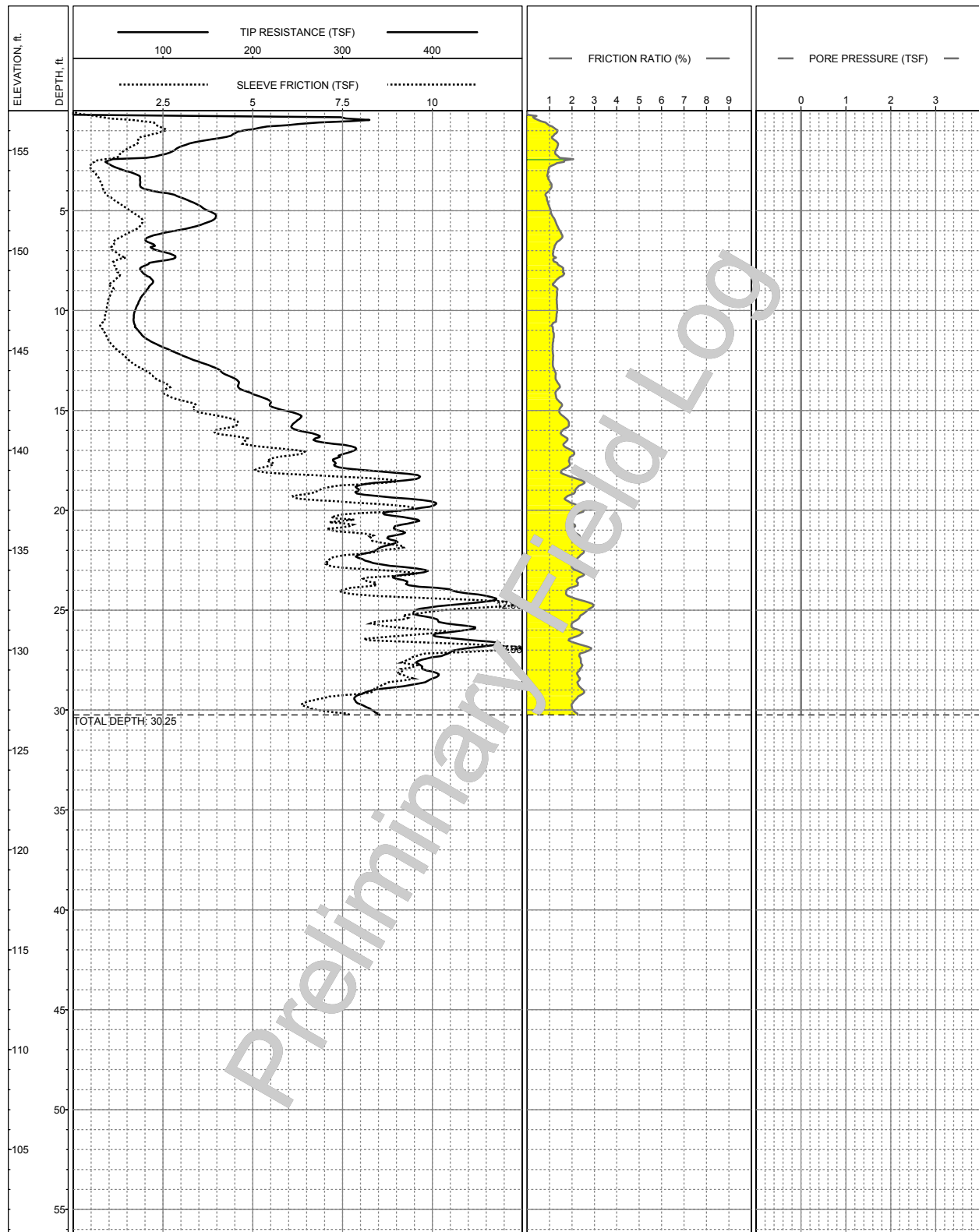

LOCATION: E5739303.06 N2135579.11 (Stateplane, CA Z4, NAD 83, Feet)
 SURFACE EL: 157ft +/- (MSL)
 COMPLETION DEPTH: 30.25ft
 TESTDATE: 3/2/2004

EXPLORATION METHOD: Cone Penetrometer
 PERFORMED BY: Fugro Geosciences
 REVIEWED BY: C A Wockner

LOG OF CPT-19
 North Campus Housing
 California State University
 Monterey Bay

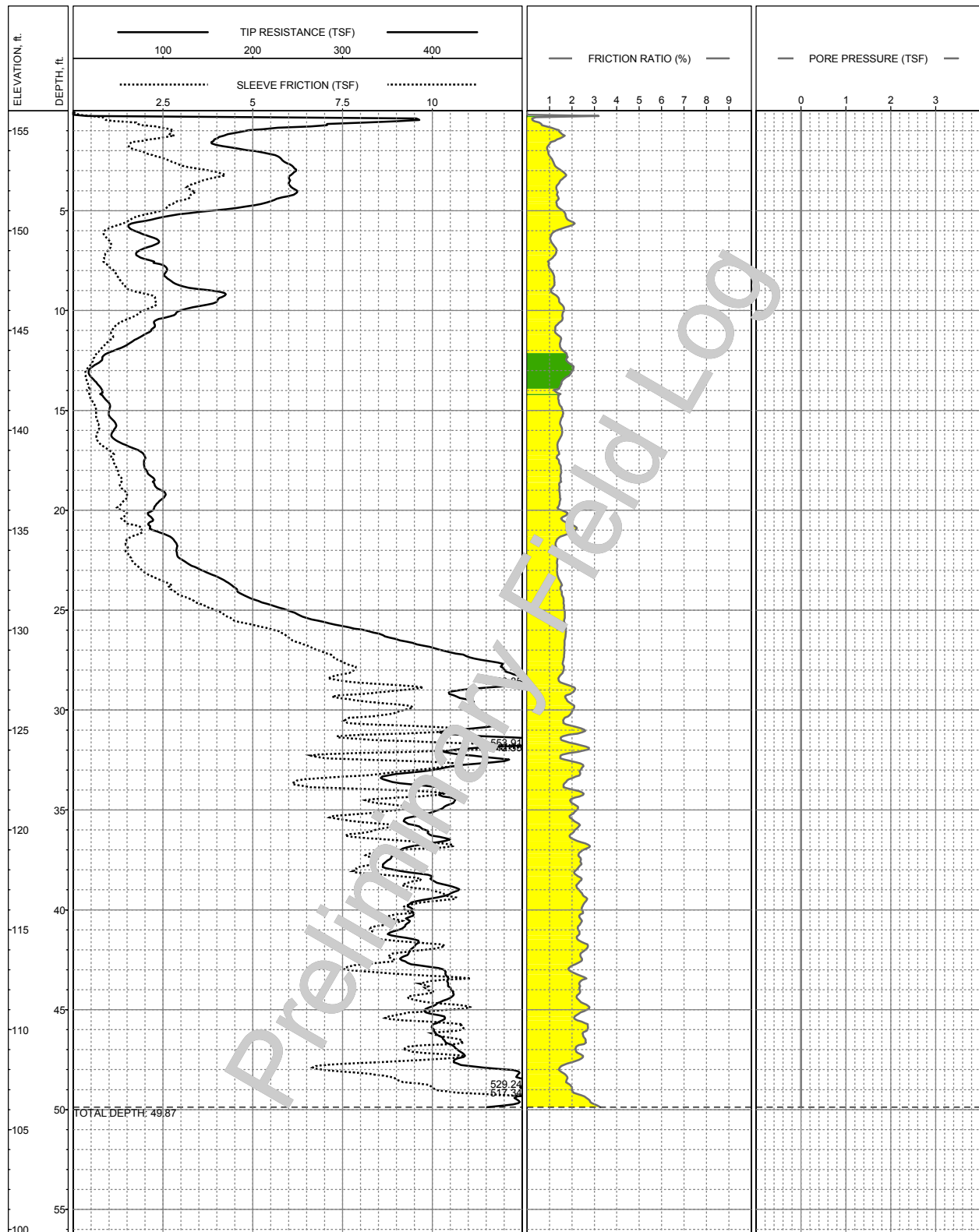

LOCATION: E5739289.32 N2135276 (Stateplane, CA Z4, NAD 83, Feet)
 SURFACE EL: 156ft +/- (MSL)
 COMPLETION DEPTH: 49.87ft
 TESTDATE: 3/2/2004

EXPLORATION METHOD: Cone Penetrometer
 PERFORMED BY: Fugro Geosciences
 REVIEWED BY: C A Wockner

LOG OF CPT-20
 North Campus Housing
 California State University
 Monterey Bay

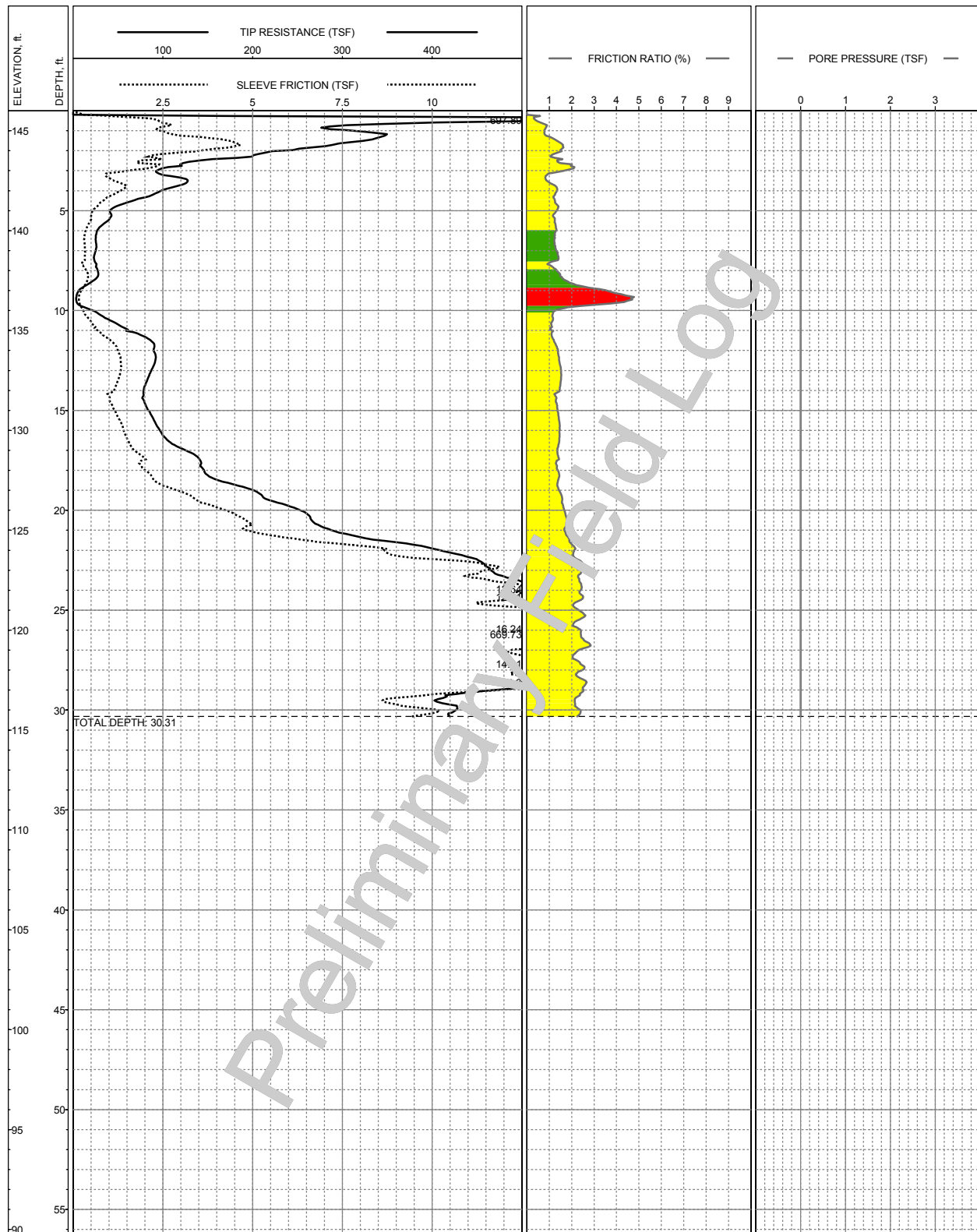

LOCATION: E5738972.05 N2135297.41 (Stateplane, CA Z4, NAD 83, Feet)
 SURFACE EL: 146ft +/- (MSL)
 COMPLETION DEPTH: 30.31ft
 TESTDATE: 3/2/2004

EXPLORATION METHOD: Cone Penetrometer
 PERFORMED BY: Fugro Geosciences
 REVIEWED BY: C A Wockner

LOG OF CPT-21
 North Campus Housing
 California State University
 Monterey Bay

APPENDIX B LABORATORY TESTING

Laboratory tests were performed on selected California liner and bulk soil samples to estimate engineering characteristics of the various earth materials encountered. Testing was performed in accordance with ASTM Standards for Soil Testing, latest revision or as noted otherwise. Laboratory test results are summarized on Plate B-1 - Summary of Laboratory Test Results.

Laboratory Moisture and Density Determinations

Moisture content and dry density determinations were performed on selected samples. The results are presented on the boring logs and Plate B-1.

Expansion Index Test

An expansion index test was performed on a sample of near-surface soil to estimate expansion characteristics. The test was performed in general accordance with ASTM D4329. The result is presented on Plate B-1.

Grain-Size Distribution

Grain size distribution was determined in general accordance with standard test method ASTM D422. In addition, we performed tests to determine the amount of material in soils finer than the No. 200 Sieve in accordance with ASTM test method D1140. The grain-size curves are presented on Plate B-2 - Grain Size Curves, and the results of percent passing the No. 200 sieve (or fines content) are presented on the boring logs and Plate B-1.

Compaction Tests

Compaction tests were performed on selected bulk samples of native materials to assess compaction characteristics. The tests were performed in general accordance with ASTM D1557. Compaction curves are presented on Plates B-3a through B-3c - Compaction Test Results. Maximum dry densities and optimum moisture contents are tabulated on Plate B-1.

Direct Shear Tests

Direct shear strength tests were performed on soil specimens compacted to about 90 percent of the maximum dry density at about optimum moisture content. The samples were pre-loaded with a confining pressure and then flooded with water for at least twenty-four hours. The samples were sheared horizontally at a controlled strain rate, allowing partial drainage. The shear stress on the samples was recorded at regular strain intervals. The results of the direct shear tests are tabulated on Plate B-1, and presented on Plates B-4a through B-4c - Direct Shear Test Results.



Hydroconsolidation Tests

Limited one-dimensional consolidation tests were performed on selected liner samples in general accordance with ASTM Test Method 2435 to estimate the hydroconsolidation (collapse) potential of the sandy native soils. The samples were loaded to the approximate overburden pressure and then inundated with water. The collapse potential was measured after the samples had achieved equilibrium after inundation. The results of the hydroconsolidation tests are presented on Plates B-5a through B-5d - Hydroconsolidation Test Results.

Soil Chemistry Tests/Corrosion Tests

Samples of soil in the upper 5 feet at three locations were tested for resistivity, pH, sulfate, and chloride content to assess corrosion potential by Health Science Associates, Inc., of Los Alamitos, California. The results of the tests are presented on Plate B-6 - Laboratory Report (Health Science Associates' report), and are summarized on Plate B-1.

R-Value Test

R-value tests were performed samples of near-surface soil at three locations on the site. The tests were performed in accordance with standard test method ASTM D2844 and results of the tests are summarized on Plate B-1.





DRILL HOLE	DEPTH, #	SAMPLE NUMBER	MATERIAL DESCRIPTION	UWW pcf	UDW pcf	MC %	FINES %	ATTERBERG LIMITS		COMPACTION TEST		DIRECT SHEAR		COMPRESSIVE STRENGTH TESTS		CORROSIIVITY TESTS				EXPANSION INDEX (SE)	TEST LISTING
								LL	PI	MAX DD pcf	OPT MC %	C ksf	PHI deg	Q _u ksf	S _u (Cell Pres.) ksf	R	pH	CI	So ₁		
B-1	1.5		Fine to Medium SAND with silt (SP-SM)				11														S
B-1	2.0		Fine to Medium SAND with silt (SP-SM)	109	99	10															T
B-1	5.0		Fine to Medium SAND with silt (SP-SM)	110	101	8															T
B-1	10.5		Fine SAND with silt (SP-SM)				3														M, FC
B-1	16.0		Fine SAND (SP)	111	107	4	3														T, C, FC
B-2	2.0		Fine SAND with silt (SP-SM)	107	100	6															T
B-2	3.5		Fine SAND with silt (SP-SM)	102	96	6															T
B-2	5.0		Fine SAND with silt (SP-SM)	106	100	5															T, C
B-2	10.5		Fine SAND (SP)	105	99	5															T
B-3	1.5		Fine to Medium SAND (SP)				6														S
B-3	2.0		Fine to Medium SAND (SP)	115	107	8															T
B-3	3.5		Fine to Medium SAND (SP)	120	115	4															T
B-3	5.0		Fine SAND (SP)	105	99	6	4														T, FC
B-3	10.5		Fine SAND (SP)	102	96	6															T
B-4	1.0		Fine to Medium SAND with silt and gravel (SP-SM)	122	111	10	10		124.0	8.5	0.3	37			410	8.53	<25	0.317	78		T, P, D, S, Co, R
B-4	2.0		Fine to Medium SAND with silt and gravel (SP-SM)	118	112	6															T
B-4	3.5		Fine to Medium SAND with silt and gravel (SP-SM)	99	87	14															T
B-4	5.0		Fine to Medium SAND with silt and gravel (SP-SM)	92	85	9															T
B-4	9.5		Fine SAND (SP)				4														M, FC
B-5	1.5		Fine SAND (SP)				4														S
B-5	2.0		Fine SAND (SP)	102	99	3															T
B-5	3.5		Fine SAND (SP)	97	95	3															T
B-5	5.0		Fine SAND (SP)	106	104	2															T
B-5	10.5		Fine SAND (SP)				4														FC
B-6	1.0		Silty Fine SAND (SM)	118	107	11	13		120.0	9.0	0.1	35			3800	7.53	<25	0.004	72	0	T, P, D, S, Co.
B-6	2.0		Silty Fine SAND (SM)	95	90	6															R, EI
B-6	3.5		Silty Fine SAND (SM)	18	17	5															T
B-6	5.0		Silty Fine SAND (SM)	105	100	6															T
B-6	10.5		Fine SAND (SP)	106	102	4	2														T, FC

SUMMARY OF LABORATORY TEST RESULTS

North Campus Housing
California State University
Monterey Bay

Classification Tests
UWW = Unit Wet Weight
UDW = Unit Dry Weight
MC = Moisture Content
Fines = % Passing #200 Sieve
LL = Liquid Limit
PI = Plasticity Index

Direct Shear Test
C = Assigned Cohesion, ksf
PHI = Assigned Friction Angle, degrees
Compaction Test
MAX DD = Maximum Dry Density
OPT MC = Optimum Moisture Content

Compressive Strength Tests
Q_u = Unconfined Compression
S_u = Undrained Shear Strength
u = Unconsolidated Undrained
p = Pocket Penetrometer
t = Torvane
m = Miniature Vane

Corrosivity Tests
R = Resistivity, ohm-cm, satur.
pH = pH
Cl = Chloride, ppm
SO₄ = Sulfate, % by weight

Test Listing Abbreviations
M = Moisture Content
T = Total & Dry Unit Weight
S = Sieve Analysis
FC = % Passing #200 Sieve
H = Hydrometer Analysis
A = Atterberg Limits
P = Compaction Test

D = Direct Shear Test
C = Consolidation Test
Co = Corrosivity Tests
CU = CU Triaxial
U = UU Triaxial
R = R-Value
SE = Sand Equivalent



DRILL HOLE	DEPTH, #	SAMPLE NUMBER	MATERIAL DESCRIPTION	UWW		MC FINES		ATTERBERG LIMITS		COMPACTION TEST		DIRECT SHEAR		COMPRESSIVE STRENGTH TESTS		CORROSION TESTS				EXPANSION INDEX (SE)	TEST LISTING
				pcf	pcf	%	%	LL	PI	MAX DD pcf	OPT MC %	C ksf	PHI deg	Qu, ksf	S _u (Cell Pres.) ksf	R	pH	CI	So ₁		
B-6	20.5		Fine SAND (SP)	109	102	7														T, C	
B-7	0.0		AC			4														M	
B-7	1.0		Fine to Medium SAND (SP)	106	98	8	4			110.0	7.0	0.0	46	6400	6.89	<25	<.003	72		T, P, D, S, Co, R	
B-7	2.0		Fine to Medium SAND (SP)	100	96	4														T	
B-7	3.5		Fine to Medium SAND (SP)	99	95	5														T	
B-7	5.0		Fine to Medium SAND (SP)	107	102	5														T	
B-7	10.5		Fine to Medium SAND (SP)	97	93	4	1													T, FC	
B-7	16.0		Fine to Medium SAND (SP)				3													S	
B-8	0.0		AC	107	101	6														T	
B-8	1.5		Fine SAND (SP)																		
B-8	15.5		Fine SAND (SP)	102	98	4														T, C	
B-9	3.5		Silty Fine SAND (SM)				15													S	
B-10	8.5		Silty Fine SAND (SM)				16													S	

Classification Tests
 UWW = Unit Wet Weight
 UDW = Unit Dry Weight
 MC = Moisture Content
 Fines = % Passing #200 Sieve
 LL = Liquid Limit
 PI = Plasticity Index

Direct Shear Test
 C = Assigned Cohesion, ksf
 PHI = Assigned Friction Angle, degrees
 Compaction Test
 MAX DD = Maximum Dry Density
 OPT MC = Optimum Moisture Content

Compressive Strength Tests
 Qu = Unconfined Compression
 Su = Undrained Shear Strength
 u = Unconsolidated Undrained
 p = Pocket Penetrometer
 t = Torvane
 m = Miniature Vane

Corrosivity Tests
 R = Resistivity, ohm-cm, satur.
 pH = pH
 CI = Chloride, ppm
 SO₄ = Sulfate, % by weight

Test Listing Abbreviations
 M = Moisture Content
 T = Total & Dry Unit Weight
 S = Sieve Analysis
 FC = % Passing #200 Sieve
 H = Hydrometer Analysis
 A = Atterberg Limits
 P = Compaction Test
 D = Direct Shear Test
 C = Consolidation Test
 Co = Corrosivity Tests
 CU = CU Triaxial
 U = UU Triaxial
 R = R-Value
 SE = Sand Equivalent

SUMMARY OF LABORATORY TEST RESULTS
 North Campus Housing
 California State University
 Monterey Bay



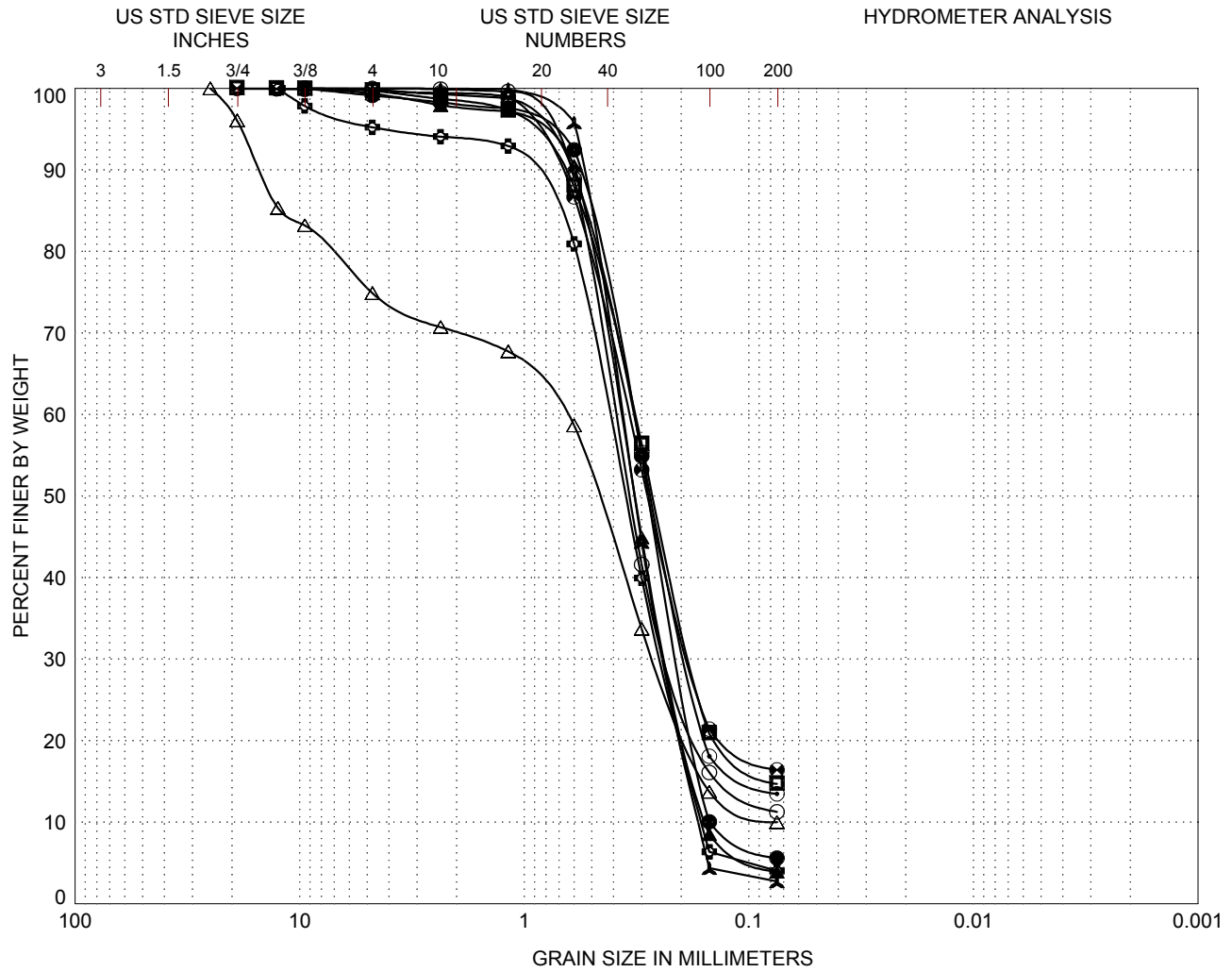

GRAVEL		SAND			SILT or CLAY
Coarse	Fine	Coarse	Medium	Fine	

LEGEND		CLASSIFICATION	Cc	Cu	
(location)	(depth,ft)				
○	B-1	1.5'	Fine to Medium SAND with silt (SP-SM)	1.9	6.3
●	B-3	1.5'	Fine to Medium SAND (SP)	0.8	2.2
△	B-4	1.5'	Fine to Medium SAND with silt and gravel (SP-SM)	1.4	8.8
▲	B-5	1.5'	Fine SAND (SP)	0.9	2.4
⊙	B-6	1.5'	Silty Fine SAND (SM)		
⊕	B-7	1.5'	Fine to Medium SAND (SP)	0.9	2.6
▲	B-7	16'	Fine to Medium SAND (SP)	0.9	2.2
⊠	B-9	2.5-3.5'	Silty Fine SAND (SM)		
⊗	B-10	8.5-10'	Silty Fine SAND (SM)		

GRAIN SIZE CURVES
 North Campus Housing
 California State University
 Monterey Bay



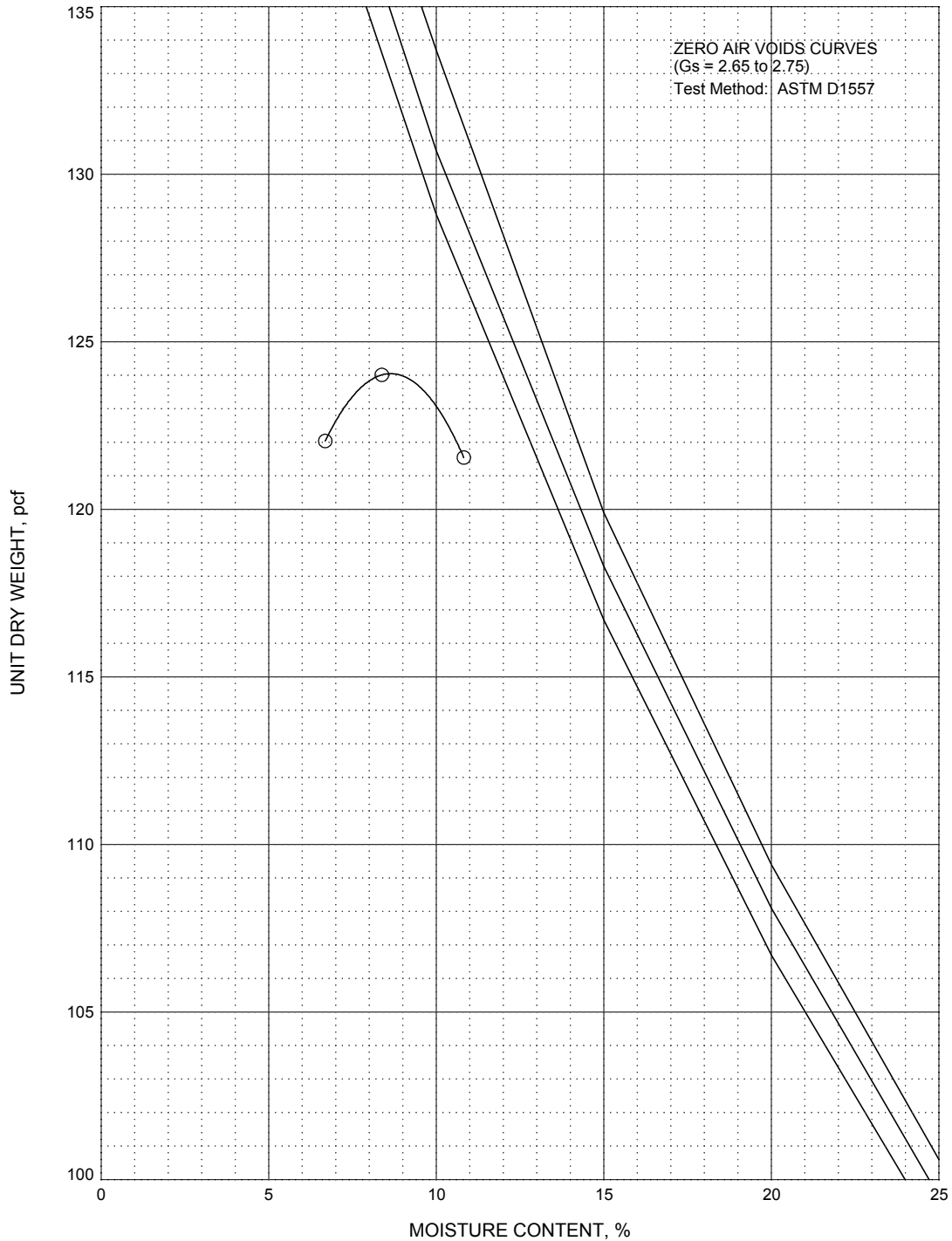

<u>LEGEND</u>		<u>CLASSIFICATION</u>	<u>MAXIMUM UNIT DRY WEIGHT, pcf</u>	<u>OPTIMUM WATER CONTENT, %</u>
(location)	depth, ft			
○ B-4	1-5	Fine to Medium SAND with silt and gravel (SP-SM)	124.0	8.5

COMPACTION TEST RESULTS
 North Campus Housing
 California State University
 Monterey Bay

PLATE B-3a



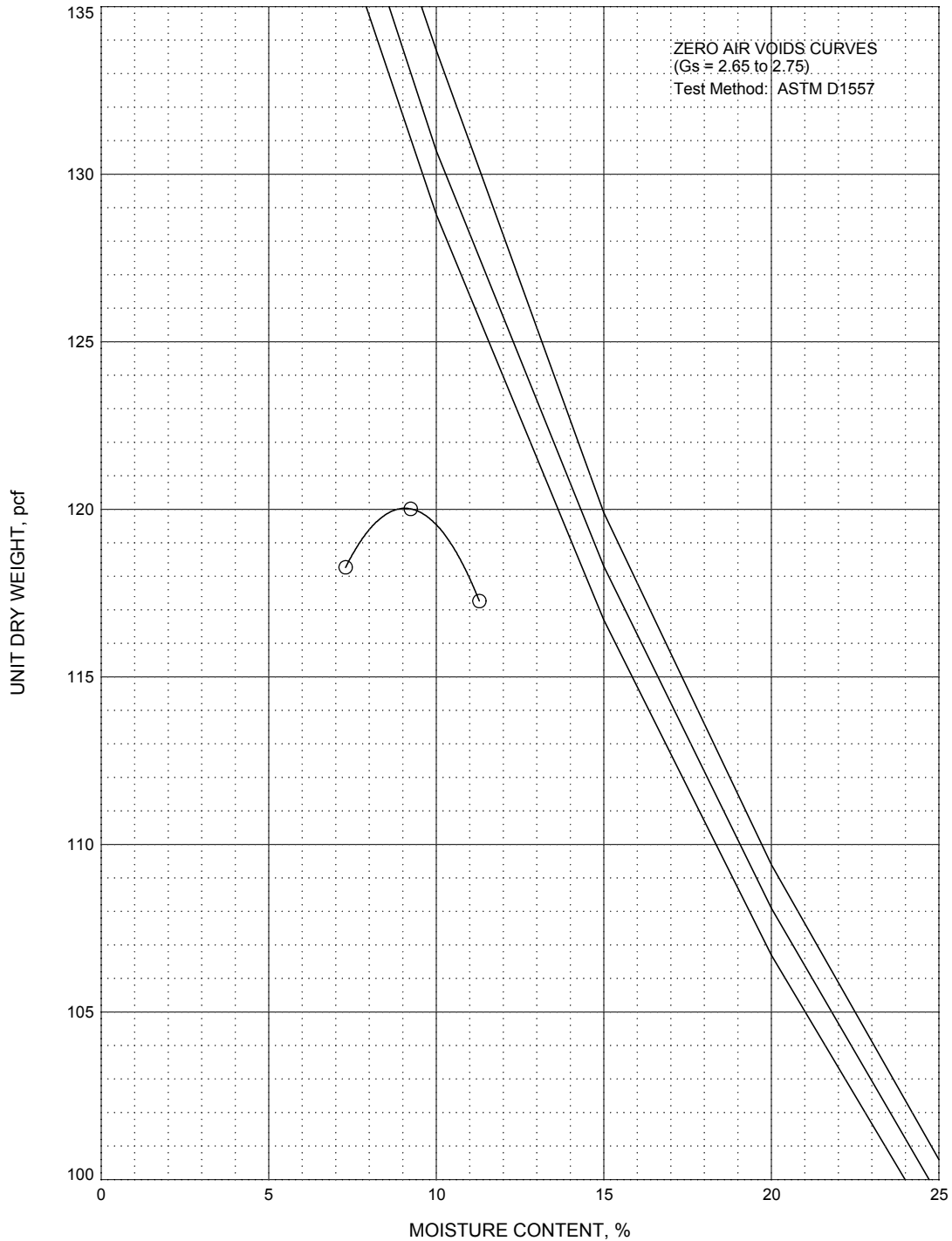

LEGEND
 (location) depth, ft
 ○ B-6 1-5

CLASSIFICATION
 Silty Fine SAND (SM)

MAXIMUM UNIT DRY WEIGHT, pcf
 120.0

OPTIMUM WATER CONTENT, %
 9.0

COMPACTION TEST RESULTS
 North Campus Housing
 California State University
 Monterey Bay

PLATE B-3b



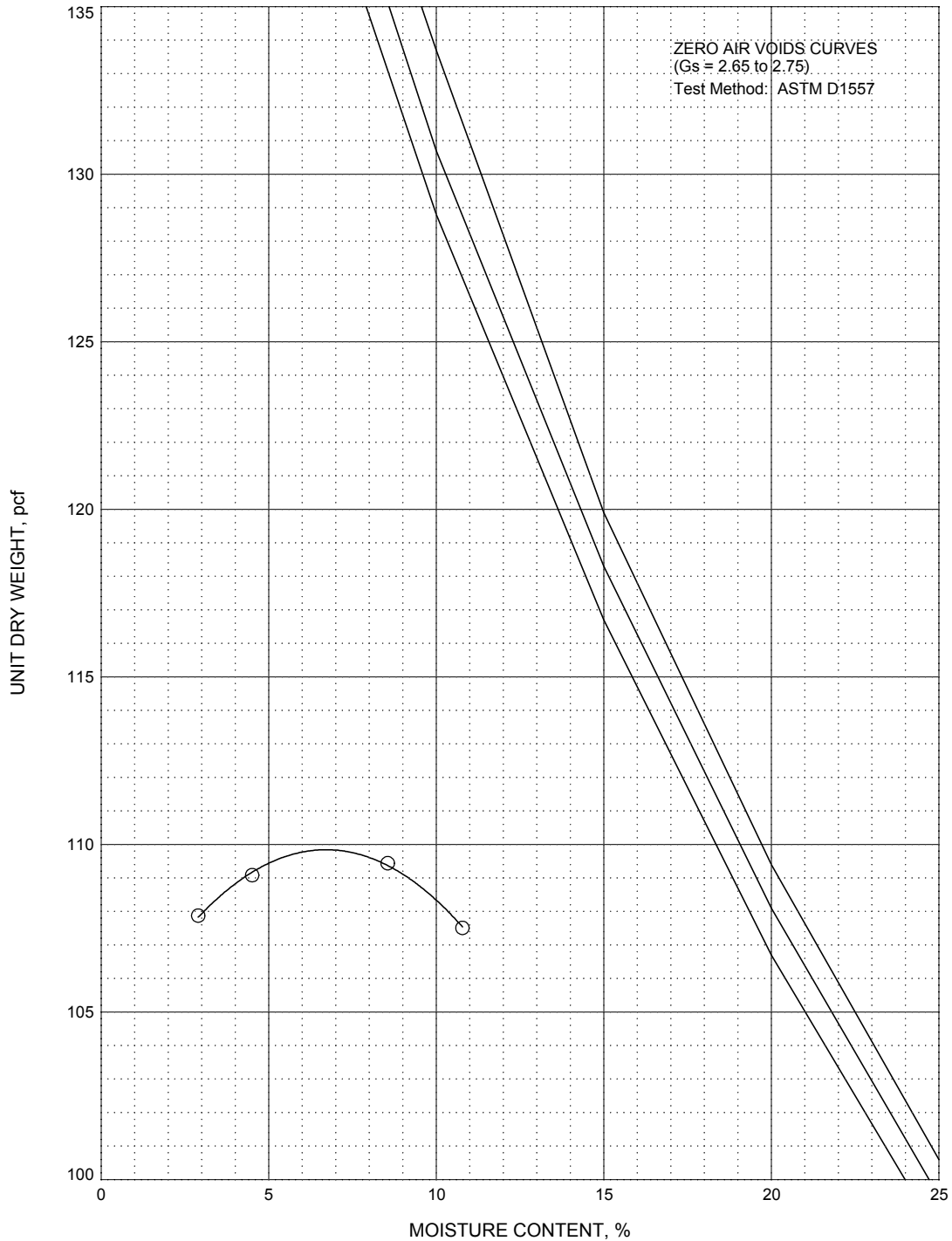

LEGEND
 (location) depth, ft
 ○ B-7 1-5

CLASSIFICATION
 Fine to Medium SAND (SP)

MAXIMUM UNIT DRY WEIGHT, pcf
 110.0

OPTIMUM WATER CONTENT, %
 7.0

COMPACTION TEST RESULTS
 North Campus Housing
 California State University
 Monterey Bay

PLATE B-3c



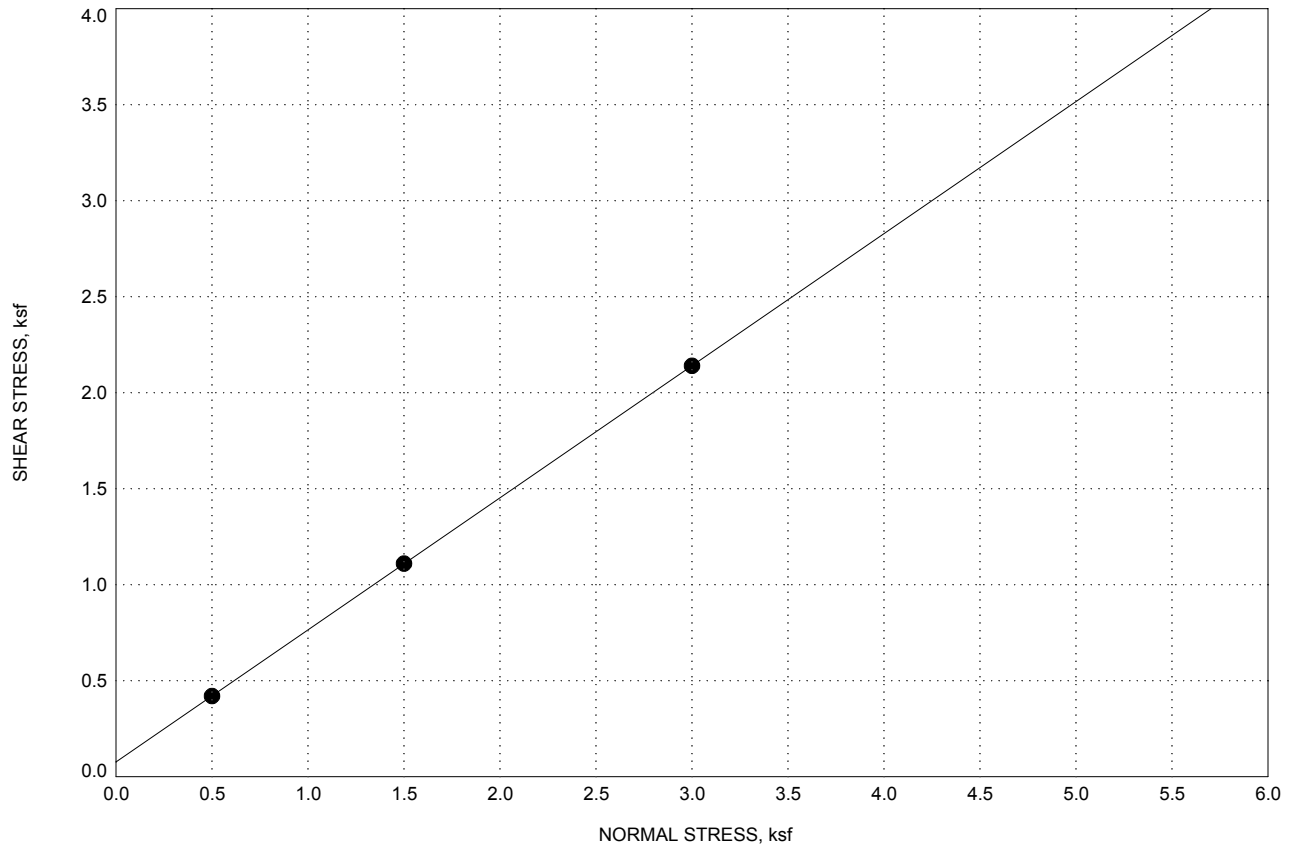

COHESION, ksf	0.1
ANGLE OF INTERNAL FRICTION, deg	35
LOCATION	B-6
DEPTH, ft	1-5
MOISTURE CONTENT, %	11
UNIT DRY WEIGHT, pcf	107
MATERIAL DESCRIPTION	Silty Fine SAND (SM)
SAMPLE CONDITION	Sample compacted to ~90% relative compaction

DIRECT SHEAR TEST RESULTS

North Campus Housing
 California State University
 Monterey Bay

PLATE B-4b



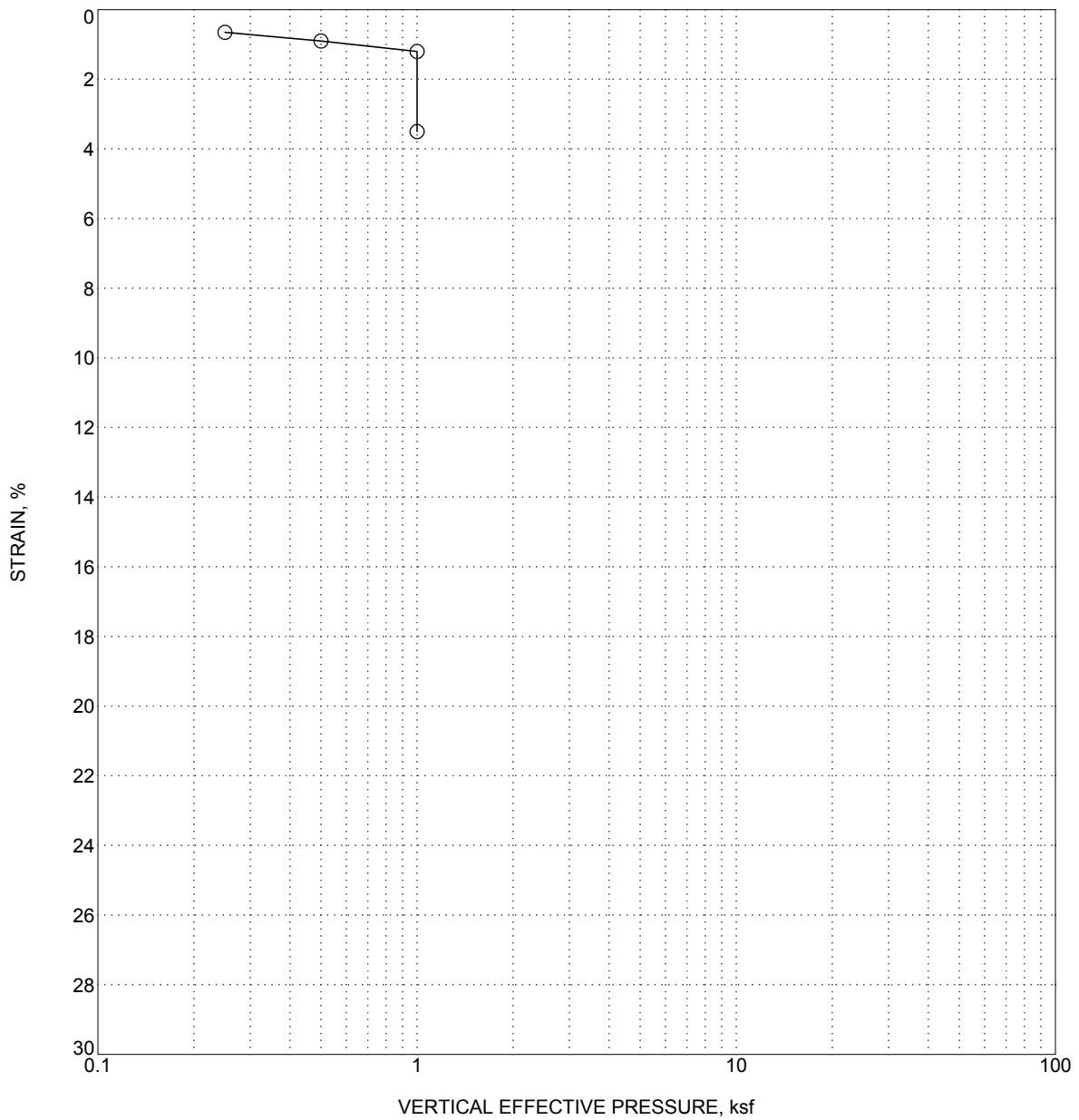

LOCATION	B-1
DEPTH, ft	16
INITIAL MOISTURE CONTENT, %	4
UNIT DRY WEIGHT, pcf	107
MATERIAL DESCRIPTION	Fine SAND (SP)
SAMPLE CONDITION	Liner Sample

HYDROCONSOLIDATION TEST RESULTS

North Campus Housing
California State University
Monterey Bay

PLATE B-5a



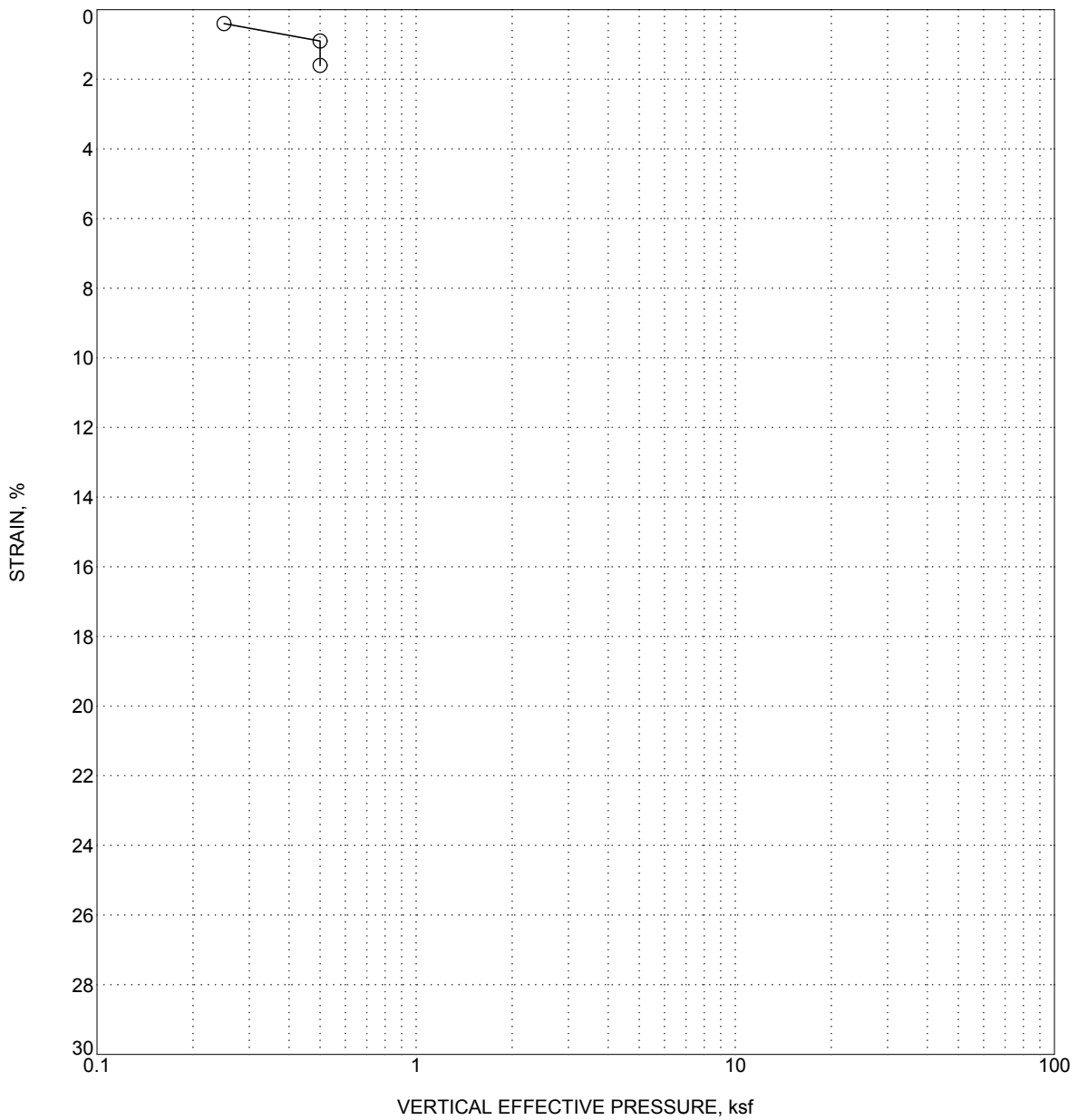

LOCATION	B-2
DEPTH, ft	5
INITIAL MOISTURE CONTENT, %	5
UNIT DRY WEIGHT, pcf	100
MATERIAL DESCRIPTION	Fine SAND with silt (SP-SM)
SAMPLE CONDITION	Liner Sample

HYDROCONSOLIDATION TEST RESULTS

North Campus Housing
California State University
Monterey Bay

PLATE B-5b



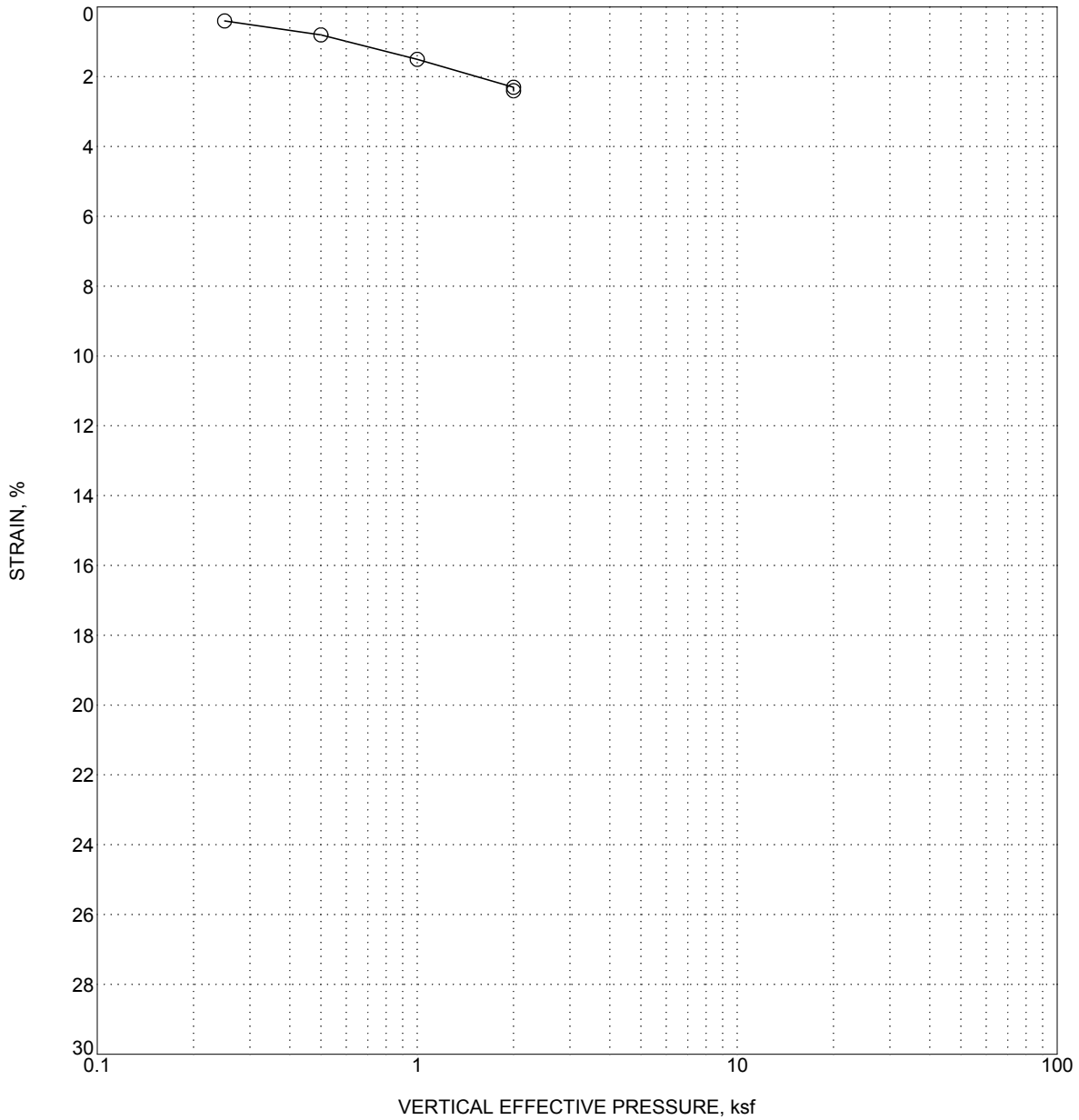

LOCATION	B-6
DEPTH, ft	20.5
INITIAL MOISTURE CONTENT, %	7
UNIT DRY WEIGHT, pcf	102
MATERIAL DESCRIPTION	Fine SAND (SP)
SAMPLE CONDITION	Liner Sample

HYDROCONSOLIDATION TEST RESULTS

North Campus Housing
California State University
Monterey Bay

PLATE B-5c



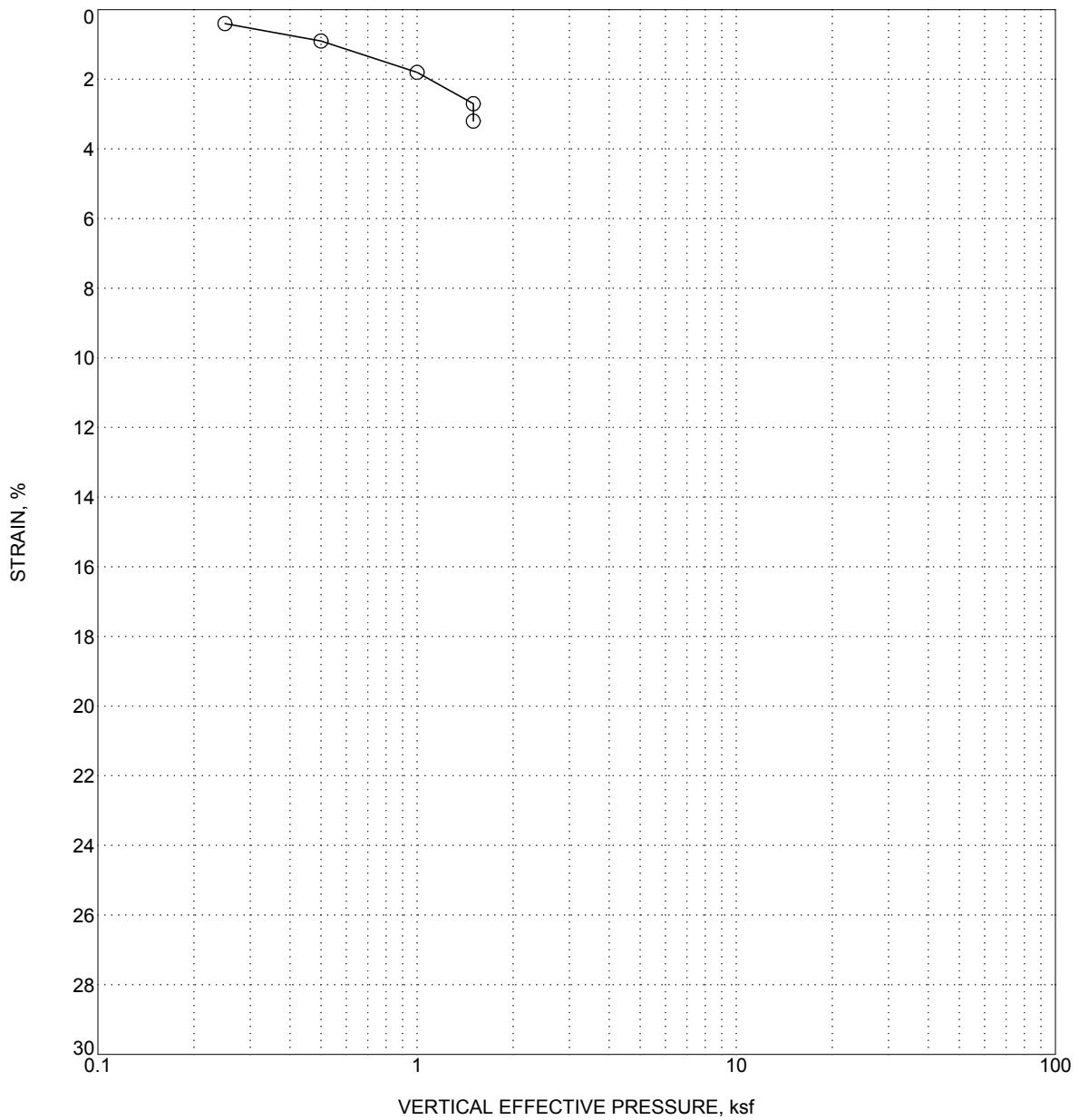

LOCATION	B-8
DEPTH, ft	15.5
INITIAL MOISTURE CONTENT, %	4
UNIT DRY WEIGHT, pcf	98
MATERIAL DESCRIPTION	Fine SAND (SP)
SAMPLE CONDITION	Liner Sample

HYDROCONSOLIDATION TEST RESULTS

North Campus Housing
California State University
Monterey Bay

PLATE B-5d





LABORATORY REPORT

Report Number : 142139.fin
Purchase Order : 9700.032/
Job No.

CAROL WOCKNER
FUGRO WEST INC.
4820 MC GRATH ST.
VENTURA, CA. 93003

Date Received : 16-MAR-04
Date Completed : 24-MAR-04
Date Sent : 24-MAR-04
Page # 1 of 1

Sample Description : 4- Bulk Soils

California Test Methods : 532,643

Auto No.	Submitter Sample Number	Resistivity ohms/cm	pH Units	Chloride ppm	Water Soluble Sulfate in Soil wt%
320599	DH-4	410	8.53	<25	0.317
320600	DH-6	3800	7.53	<25	0.0037
320601	DH-7	6400	6.89	<25	<0.0025

Sample No.	Resistivity Ohm-cm								
	50	100	150	200	250	300	350	400	
320599	880	760	430	410	410				
320600	5100	4200	4000	3800	3800				
320601	8200	7900	6800	6400	6400				

Remarks : Sample(s) and sampling data as provided :
by : G. Godinez

Analyst(s) : DL/WS Ref :

California ELAP No.: 1406
AIHA Accreditation No.: 172
NVLAP Accreditation No.: 101384
AIHA ELLAP Accreditation No.: 10985
LACSD Lab No.: 10125

Reviewed by:
Michael Chapman
Technical Approval:
Laboratory Director, Jamie Steedman-Lyde

Geotechnical Consultants Inc. 1979¹

¹ Please see Figure 5 for full citation.

RESERVATION ROAD BRANCH BORING LOCATION MAP

JOB V78020 APR.1979 Plate 227

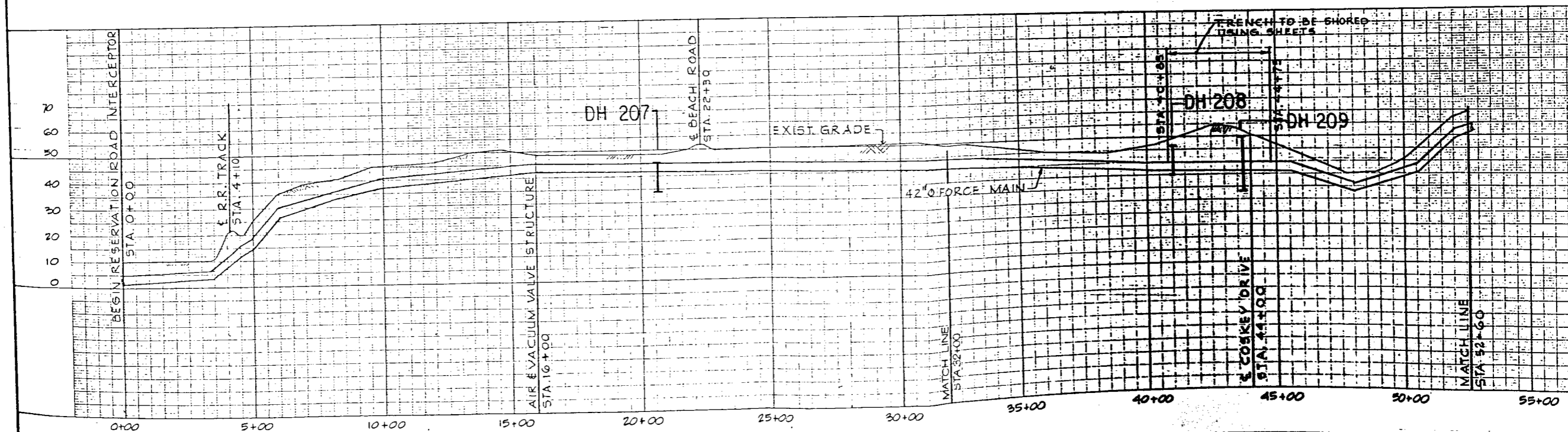
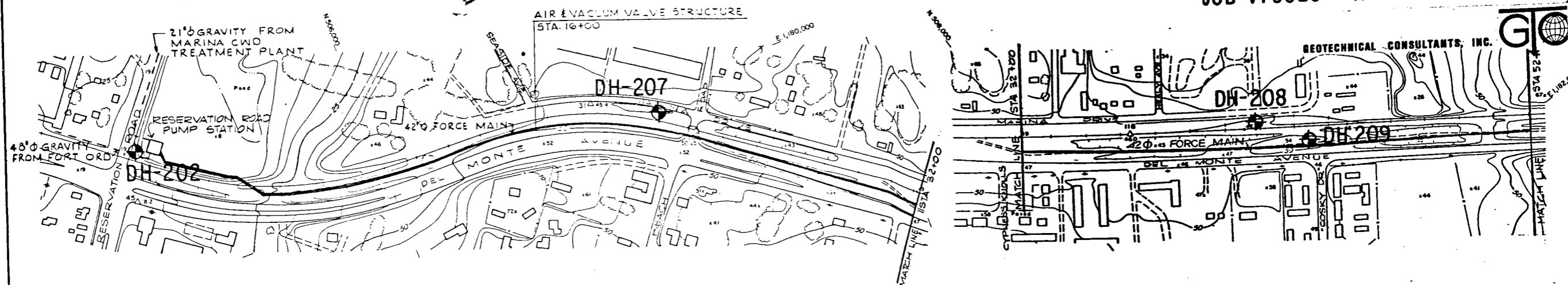

PROJECT NO.	DATE		
DESIGNED BY D E C			
DRAWN BY E A C			
CHECKED BY M S C			
HORIZONTAL SCALE 1" = 20'			
VERTICAL SCALE 1" = 20'			
NO.	DATE	DESCRIPTION	BY
REVISIONS			

SCALES

ENGINEERING-SCIENCE, INC.
ENGINEERS AND CONSULTANTS
600 BANCROFT WAY BERKELEY, CALIFORNIA 94710 (415) 548-7970
SUBMITTED BY _____ DATE _____
C.E. R.E. NO.

MONTEREY PENINSULA
WATER POLLUTION CONTROL AGENCY
MONTEREY COUNTY, CALIFORNIA

STAGE 2 - REGIONAL INTERCEPTORS AND OUTFALL PROJECT
RESERVATION ROAD INTERCEPTOR STATION 0+00 TO 52+60

SHEET
P-0.11

PHOTOGRAMMETRY BY GREENWOOD AERIAL MAPPING CO.

RESERVATION ROAD BRANCH BORING LOCATION MAP

JOB V78020 APR.1979 Plate 2.28

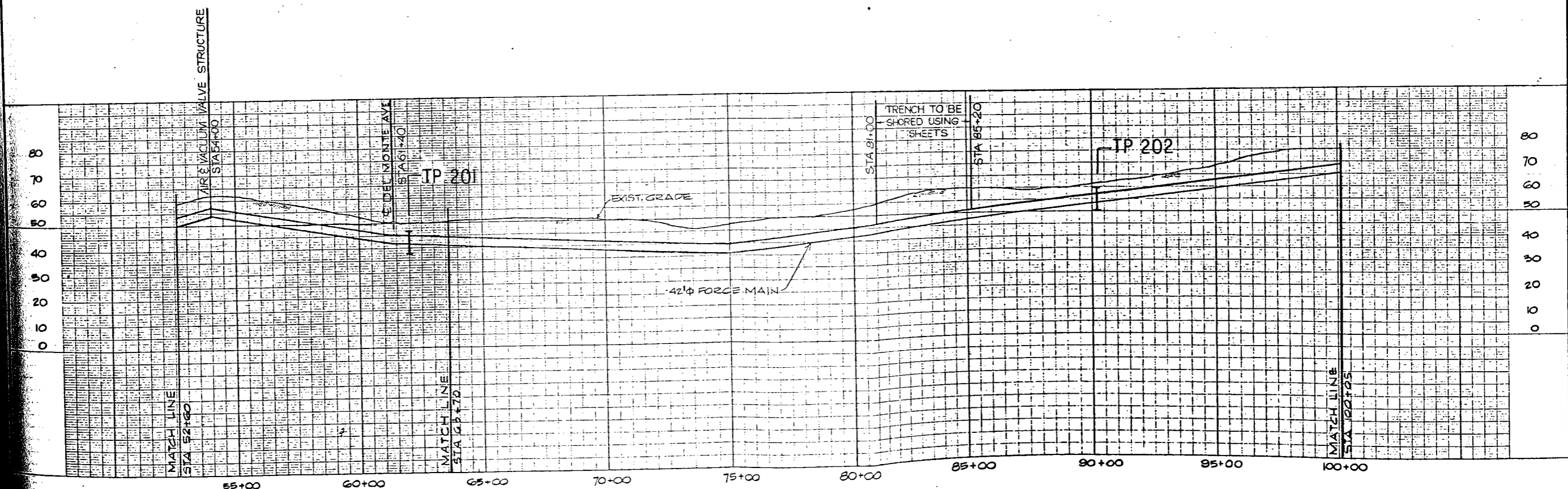
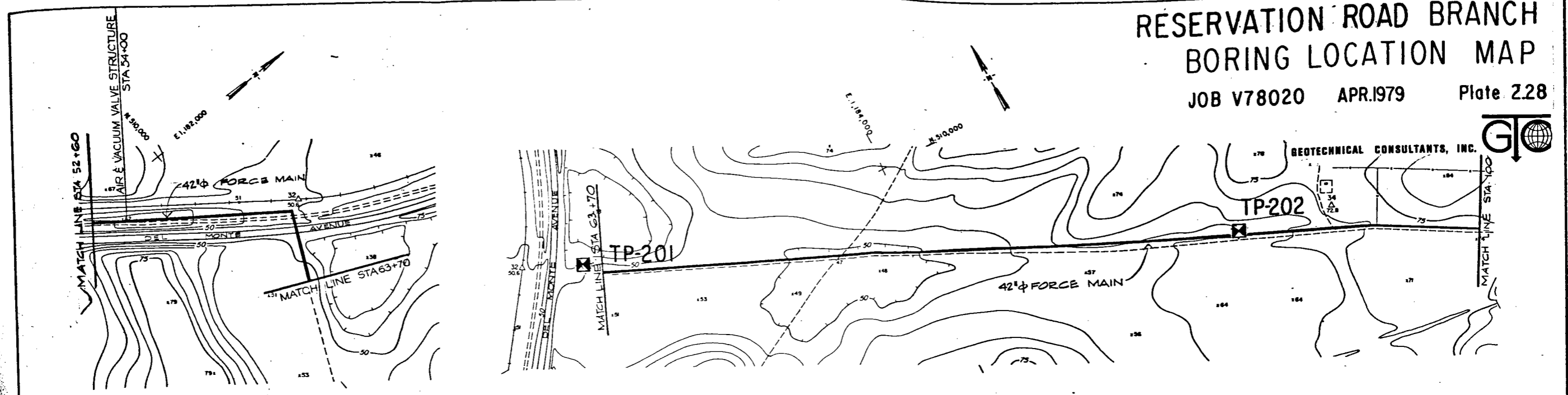

PROJECT NO.	DATE
DESIGNED BY <i>REB.</i>	
DRAWN BY <i>AD</i>	
CHECKED BY <i>M.S.C.</i>	
HORIZONTAL 1" = 200'	
VERTICAL 1" = 20'	
DATE	DESCRIPTION
	BY
	REVISIONS
	SCALE

ENGINEERING-SCIENCE, INC.
ENGINEERS AND CONSULTANTS
600 BANCROFT WAY BERKELEY, CALIFORNIA 94710 (415) 548-7970
SUBMITTED BY _____ DATE _____
C.E. _____ E.E. NO. _____

MONTEREY PENINSULA
WATER POLLUTION CONTROL AGENCY
MONTEREY COUNTY, CALIFORNIA

**STAGE 2 - REGIONAL INTERCEPTORS
AND OUTFALL PROJECT**
RESERVATION ROAD INTERCEPTOR P-012
STA. 52+60 TO 100+05

GRAMMETRY BY GREENWOOD AERIAL MAPPING CO.
PHOTOS DATED 1-25-78

LOG OF DRILL HOLE

DRILLED May 16, 1978 WITH Flight Auger
 DIAMETER OF DRILL HOLE IN INCHES 6
 LOGGED BY T. Huber

DH-207

SURFACE ELEVATION IN FEET 45 DATUM

GEOLOGICAL CLASSIFICATION DESCRIPTION	ELEVATION IN FEET	DEPTH IN FEET	SYMBOL	SAMPLES	ENGINEERING CLASSIFICATION AND DESCRIPTION	TEST DATA M - D - 0 (RC)
OLDER SAND DUNE DEPOSITS (Qod)	40	5		4	SAND (SP), brown, fine to medium grained, medium dense to dense. light yellow-brown fine to coarse grained	4-107-DS (3)
				(15) 7		
	35	10		8		
				23		
		15			Bottom of drill hole at a depth of 11 feet. No ground water. Minimal caving. Drill hole backfilled.	
		20				
		25				
		30				
		35				



V78020

Plate A-1.32

LOG OF DRILL HOLE

DRILLED May 16, 1978 WITH Flight Auger
 DIAMETER OF DRILL HOLE IN INCHES 6
 LOGGED BY T. Huber

DH-208

SURFACE ELEVATION IN FEET		44		DATUM	
GEOLOGICAL CLASSIFICATION DESCRIPTION	ELEVATION IN FEET	DEPTH IN FEET	SYMBOL	ENGINEERING CLASSIFICATION AND DESCRIPTION	TEST DATA M-D-0 (RC)
FILL (af)			SILTY SAND (SM-SP), with gray, gray-green, medium dense.	5-106 - DS
OLDER SAND DUNE DEPOSITS (Q _{od})	40	5	SAND (SP), brown, fine to medium grained, medium dense. orange-brown	
	35	10	medium dense to dense	
		15		
		20		
		25		
		30		
		35		
				Bottom of drill hole at a depth of 11½ feet. No ground water. Minimal caving. Drill hole backfilled.	

LOG OF DRILL HOLE

DRILLED May 16, 1978 WITH Flight Auger
 DIAMETER OF DRILL HOLE IN INCHES 7
 LOGGED BY T. Huber

DH 209

SURFACE ELEVATION IN FEET 50 DATUM

GEOLOGICAL CLASSIFICATION DESCRIPTION	ELEVATION IN FEET	DEPTH IN FEET	SYMBOL	SAMPLES	ENGINEERING CLASSIFICATION AND DESCRIPTION	TEST DATA M - D - 0 (RC)
OLDER SAND DUNE DEPOSITS (Qod)	45	5	.		SILTY SAND (SM-SP), brown to dark brown, fine to coarse grained, medium dense.	10-112 4-98
			.		brown to orange-brown	
	40	10	.	9	orange-brown to yellow-brown	
			.	8		
			.	(87) 11	medium dense to dense	
	35	15	.	16		
			.	30		
	30	20	.	11		
			.	(43) 21		
			.	22		
		25			Bottom of drill hole at 21½ feet. No ground water. Minimal caving. Drill hole backfilled.	
		30				
		35				

LOG OF TEST PIT

EXCAVATED May 26, 1978 WITH Backhoe

TP-201

PIT DIMENSIONS IN FEET W 2 L 18 D 8

SURFACE ELEVATION IN FEET 46 DATUM

GEOLOGICAL CLASSIFICATION DESCRIPTION	ELEVATION IN FEET	DEPTH IN FEET	SYMBOL SAMPLES	ENGINEERING CLASSIFICATION AND DESCRIPTION	TEST DATA M - ^D - 0 (RC)
OLDER SAND DUNE DEPOSITS (Qod)	45	5		SILTY SAND (SM), brown, fine to coarse grained, medium dense. orange-brown	
	40				SAND (SP), orange-brown, fine to coarse grained, medium dense.
		10		Bottom of test pit at 8 feet. No ground water. Caving from 4 to 8 feet.	
		15			

PIT DIMENSIONS IN FEET W 2 L 18 D 9

TP-202

SURFACE ELEVATION IN FEET 60

OLDER SAND DUNE DEPOSITS (Qod)	55	5		SILTY SAND (SM-SP), brown, fine to coarse grained, medium dense.	
					SAND (SP), brown to orange-brown, fine to coarse grained, medium dense to dense.
	50	10		Bottom of test pit at 9 feet. No ground water. Minimal caving.	

SHEAR TEST DATA

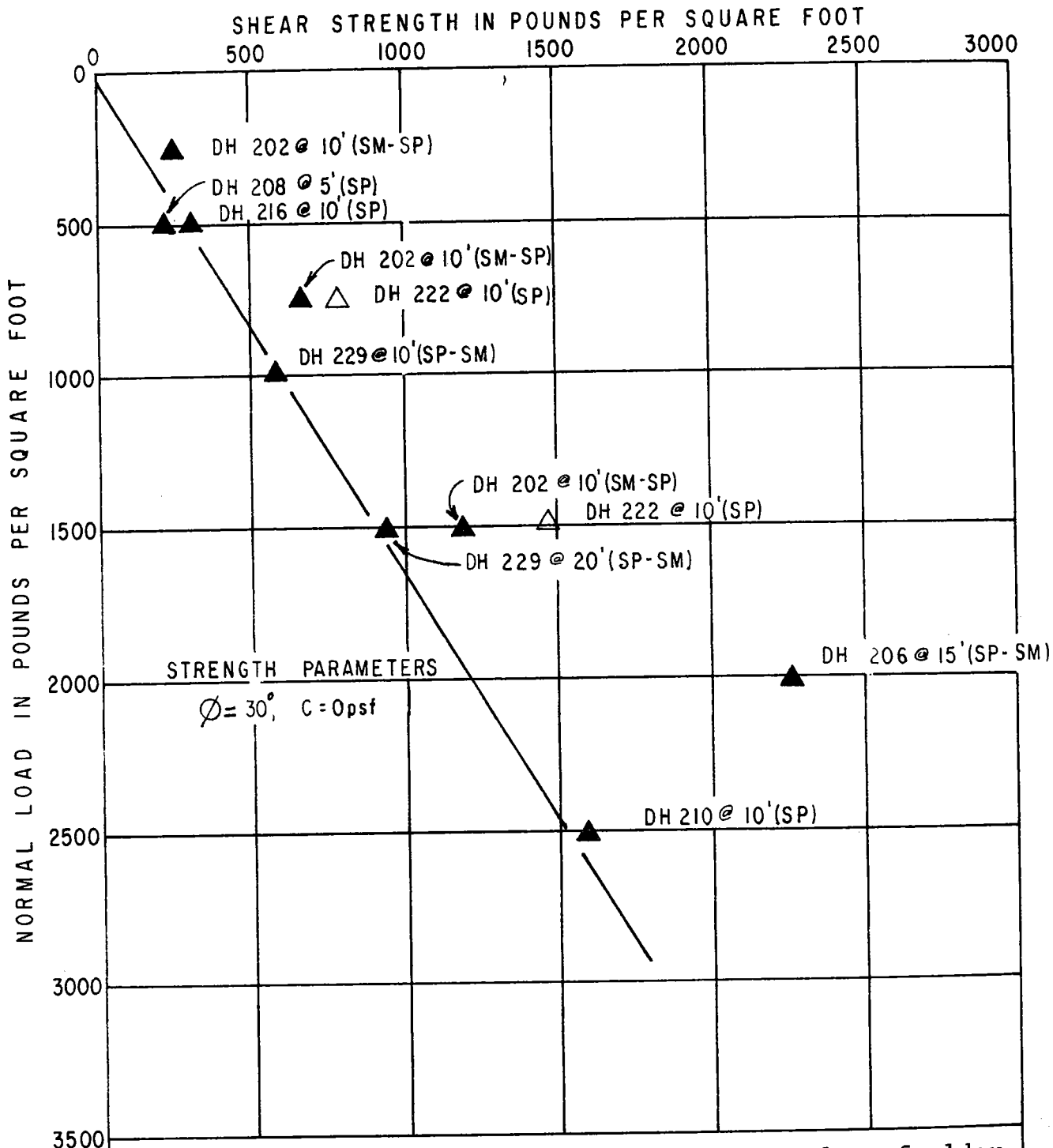

NOTE: Tests performed on undisturbed samples of older dune sand deposits.

HLA 1999¹

¹ Please see Figure 5 for full citation.

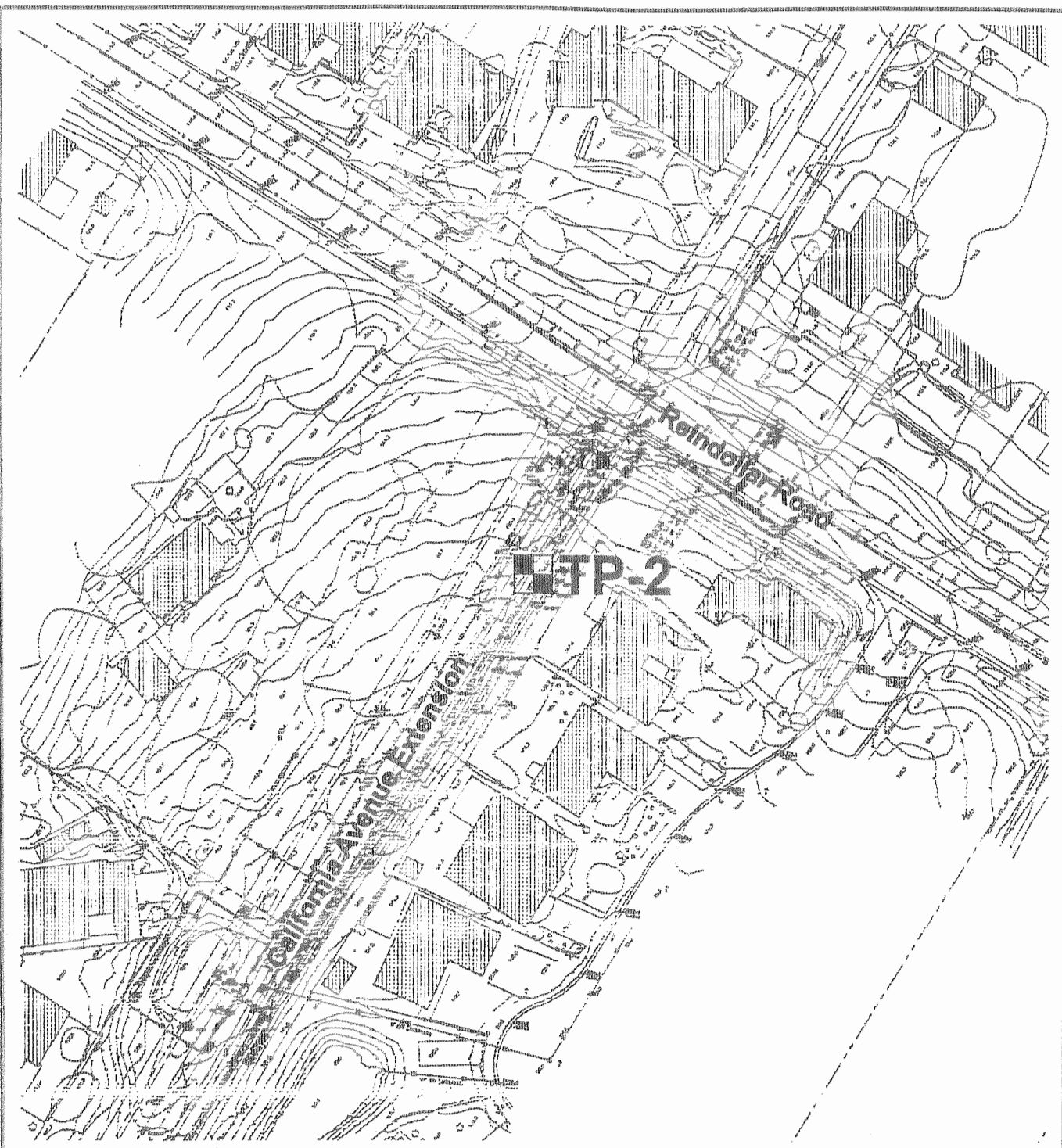

LEGEND

 TP-1 Approximate test pit location



BASE: Topographic Drawing Provided by Sandis Humber Jones

Harding Lawson Associates
Engineering and
Environmental Services

TP-2 Approximate Location
Proposed Roadway Improvements
Fort Ord Reuse Authority
Former Fort Ord and Vicinity

PLATE
2

ca_buse.rdg

DRAWN
BRZ

JOB NUMBER
46354

APPROVED

DATE
11/88

REVISED DATE

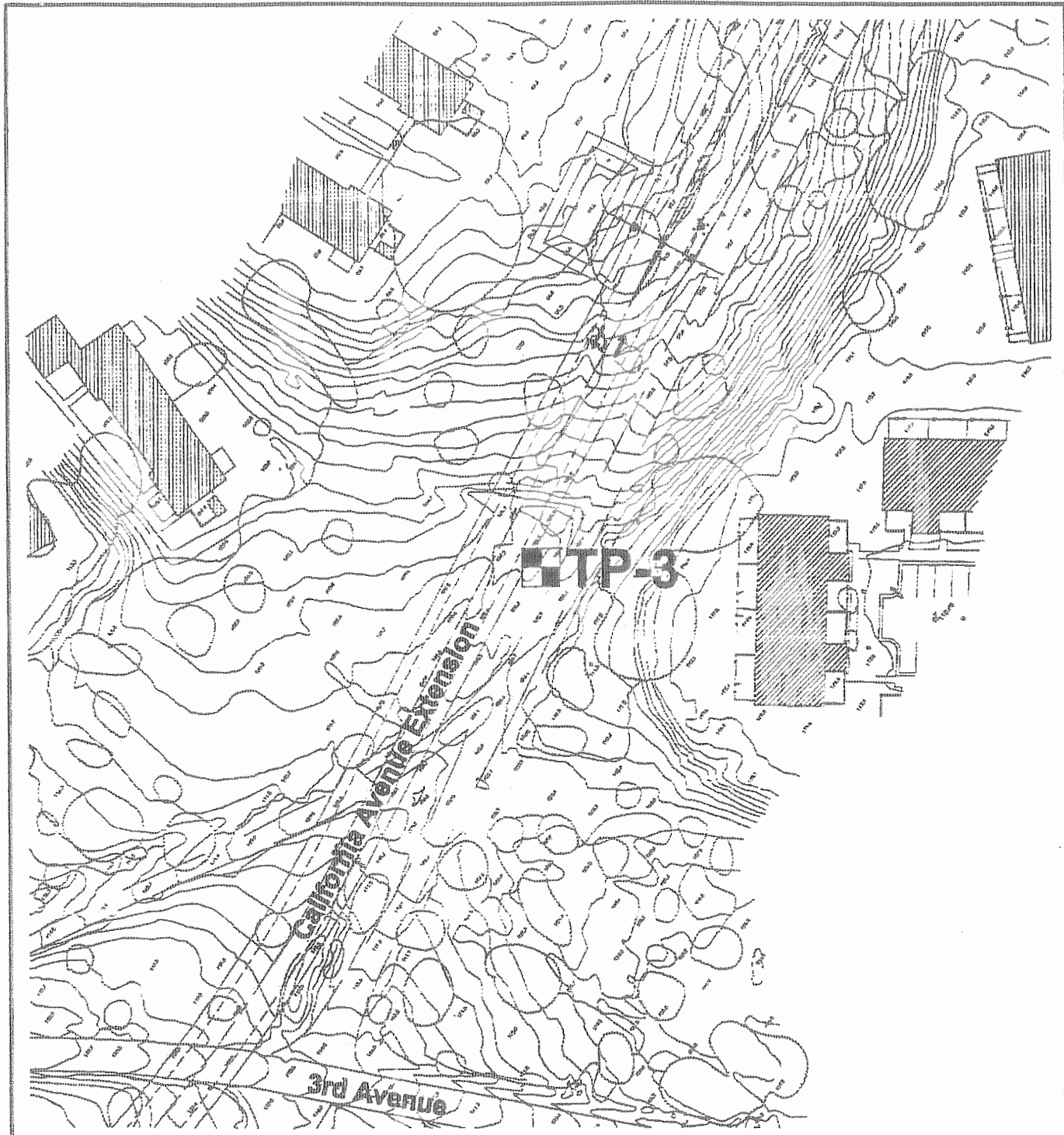

LEGEND

■ TP-1 Approximate test pit location

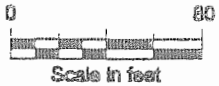

BASE: Topographic Drawing Provided by Sandra Humber Jones

Harding Lawson Associates
Engineering and
Environmental Services

TP-3 Approximate Location
Proposed Roadway Improvements
Fort Ord Reuse Authority
Former Fort Ord and Vicinity

PLATE
3

ca_base.dwg

DRAWN
BRZ

JOB NUMBER
48354

APPROVED

DATE
11/98

REVISED DATE

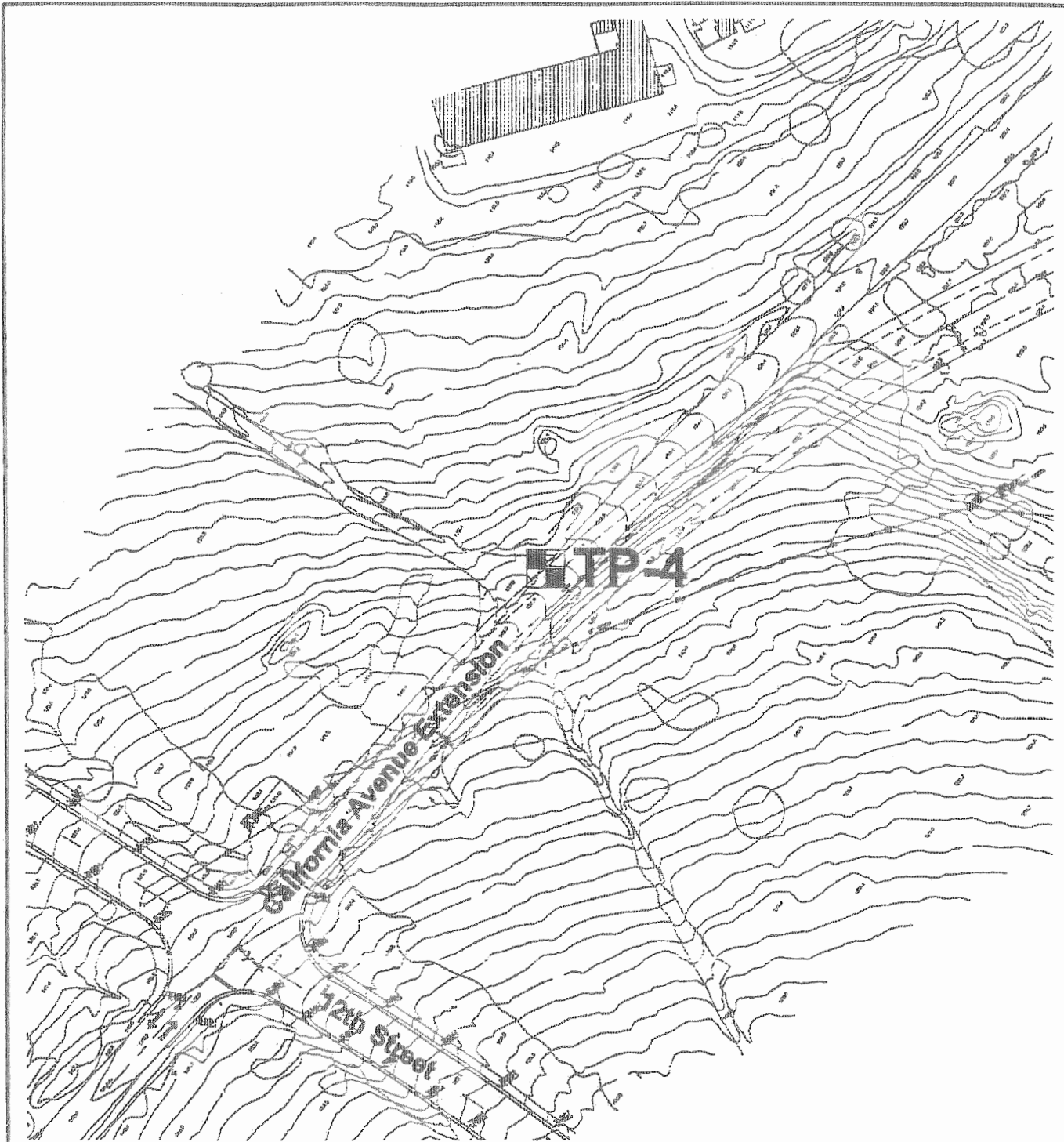

LEGEND

 TP-1 Approximate test pit location

BASE: Topographic Drawing Provided by Sandie Humber Jones

Harding Lawson Associates
Engineering and
Environmental Services

TP-4 Approximate Location
Proposed Roadway Improvements
Fort Ord Reuse Authority
Former Fort Ord and Vicinity

PLATE
4

DRAWN
BRZ

JOB NUMBER
48354

APPROVED

DATE
11/88

REVISED DATE

ca_base.dwg

MAJOR DIVISIONS			SYMBOLS	TYPICAL NAMES
COARSE-GRAINED SOILS OVER 50% > No. 200 SIEVE SIZE	GRAVELS	CLEAN GRAVELS WITH LESS THAN 5% FINES	GW	Well-graded gravels or gravel-sand mixtures, little or no fines
			GP	Poorly graded gravels or gravel-sand mixtures, little or no fines
		GRAVELS WITH OVER 15% FINES	GM	Silty gravels, gravel-sand mixtures
			GC	Clayey gravels, gravel-sand-clay mixtures
	SANDS	CLEAN SANDS WITH LESS THAN 5% FINES	SW	Well-graded sand or gravelly sands, little or no fines
			SP	Poorly graded sands or gravelly sands, little or no fines
		SANDS WITH OVER 15% FINES	SM	Silty sand, sand-silt mixtures
			SC	Clayey sands, sand-clay mixtures
FINE-GRAINED SOILS OVER 50% < No. 200 SIEVE SIZE	SILTS & CLAYS		ML	Inorganic silts and very fine sands, rock flour, silty or clayey fine sands or clayey silts with slight plasticity
	LIQUID LIMIT 50% OR LESS		CL	Inorganic clays of low to medium plasticity, gravelly clays, sandy clays, silty clays, lean clays
			OL	Organic silts and organic silty clays of low plasticity
	SILTS & CLAYS		MH	Inorganic silts, micaceous or diatomaceous fine sandy or silty soils, elastic silts
	LIQUID LIMIT GREATER THAN 50%		CH	Inorganic clays of high plasticity, fat clays
			OH	Organic clays of medium to high plasticity, organic silty clays, organic silts
	HIGHLY ORGANIC SOILS		PT	Peat and other highly organic soils

UNIFIED SOIL CLASSIFICATION SYSTEM - ASTM D2488-93

	Bulk or classification sample
	Sample preserved for possible laboratory analysis
	Lost Sample
	First encountered groundwater

CLASSIFICATION	RANGE OF GRAIN SIZES	
	U.S. Standard Sieve Size	Grain Size in Millimeters
BOULDERS	Above 12"	Above 305
COBBLES	12" to 3"	305 to 76.2
GRAVEL coarse fine	3" to No. 4	76.2 to 4.75
	3" to 3/4"	76.2 to 19.1
	3/4" to No. 4	19.1 to 4.75
SAND coarse medium fine	No. 4 to No. 200	4.75 to 0.075
	No. 4 to No. 10	4.75 to 2.00
	No. 10 to No. 40	2.00 to 0.425
	No. 40 to No. 200	0.425 to 0.075
SILT & CLAY	Below No. 200	Below 0.075

KEY TO TEST DATA*

Source: ASTM D 2488-90, based on United Soil Classification system
 * Not part of ASTM Classification System

SOIL_CLASS_GEOI.2_46354.GPJ_HLA_NOVA.GDT_11/15/99

Harding Lawson Associates
 Engineering and
 Environmental Services

Soil Classification Chart and Key to Test Data

PLATE

FORA
 Fort Ord, California

A-1

DRAWN	JOB NUMBER	APPROVED	DATE	REVISED DATE
PCB	46354		11/99	

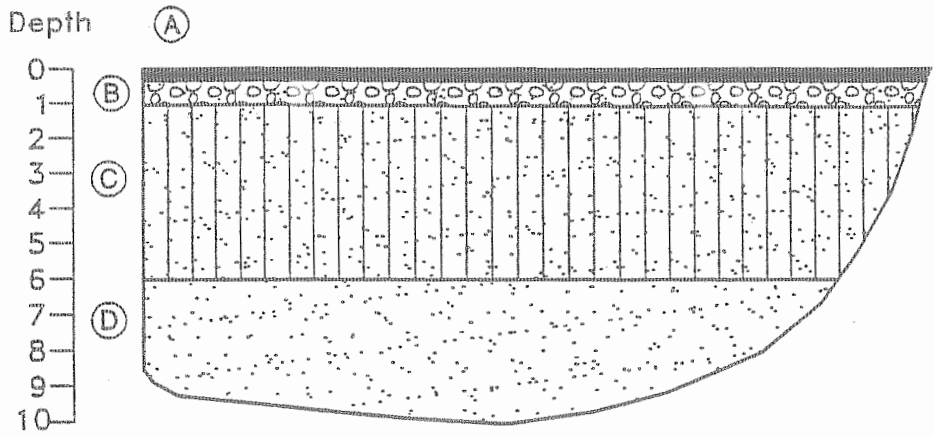

- Ⓐ ASPHALT, 3 inches thick:
- Ⓑ LIGHT GREENISH GRAY WELL GRADED GRAVEL WITH SILT (GW-GM):
Loose, dry, 70% fine to coarse gravel, 20% fine to coarse sand, 10% silt, baserock
- Ⓒ YELLOWISH BROWN SILTY SAND (SM):
Loose, moist, 80% fine to medium sand, 20% silt
- Ⓓ at 6 ft., change to WELL GRADED SAND (SW), 5% silt
at 8 ft., color change to dark yellowish brown

Notes:
Trenching on 9/22/99
Samples at 2.5, 5, 7.5 and 10 ft. BGS

46354001 DWG 1.0
19991121:450

Harding Lawson Associates
Engineering and
Environmental Services

Log of Test Pit #1
East Garrison & Reservation Rd.
FORA
Fort Ord, California

FIGURE

TP-1

DRAWN PCB	JOB NUMBER 46354 3	APPROVED	DATE 11/99	REVISED DATE
--------------	-----------------------	----------	---------------	--------------

Depth

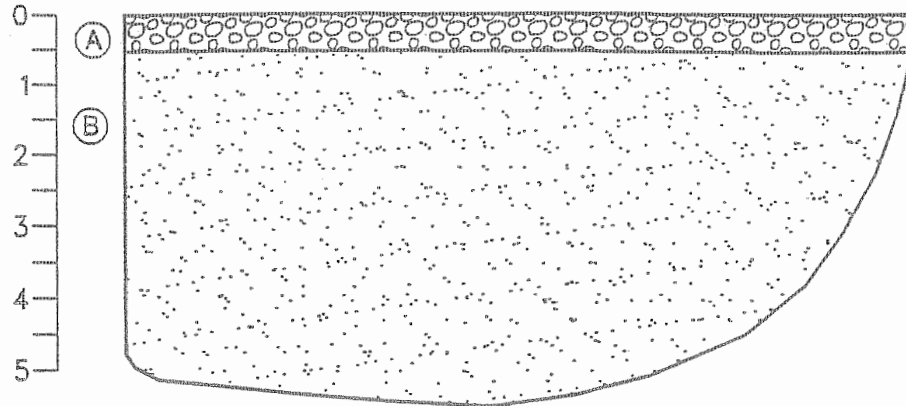

- ① LIGHT GREENISH GRAY WELL GRADED GRAVEL WITH SILT (GW-GM):
Loose, dry, 70% fine to coarse gravel, 20% fine to coarse sand, 10% silt, baserock
- ② YELLOWISH BROWN POORLY GRADED SAND WITH SILT AND GRAVEL (SP-SW) (10YR 5/6):
Loose, dry, 90% fine to coarse sand, 10% silt, roots from 1 to 5.5 ft. deep

Notes:

Trenching on 9/22/99
Samples at 2.5 and 5 ft. BGS

46354002.DWG 1.0
19991104.1805

Harding Lawson Associates
Engineering and
Environmental Services

Log of Test Pit #2
California St. Extension
FORA
Fort Ord, California

FIGURE

TP-2

DRAWN	JOB NUMBER	APPROVED	DATE	REVISED DATE
PCB	46354 3		11/99	

Depth

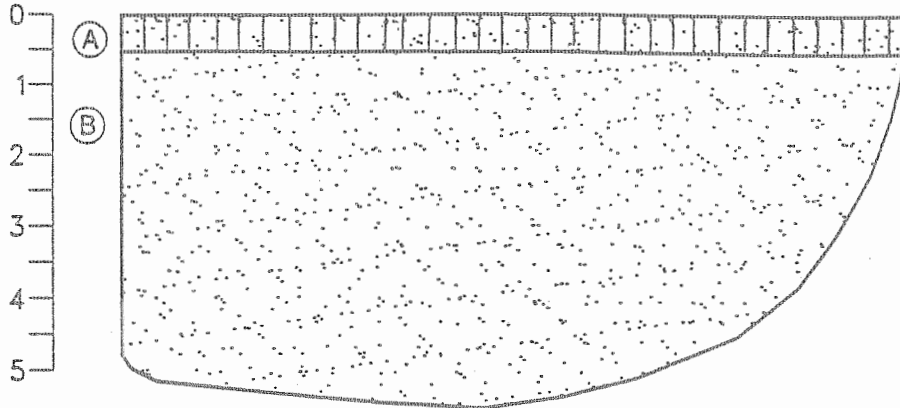

(A) LIGHT OLIVE BROWN SILTY SAND (SM) (2.5Y 5/4):
Loose, dry, 75% sand, 25% silt.

(B) LIGHT YELLOWISH BROWN POORLY GRADED SAND
(SP) (10YR 6/4):
Loose, dry, fine to coarse sand, <5% silt

@ 5 ft.: change to 100% fine to coarse sand

Notes:

Trenching on 9/22/99
Samples at 2.5 and 5 ft. BGS

46354003.DWG 1.0
19991121458

Harding Lawson Associates
Engineering and
Environmental Services

Log of Test Pit #3
East of 12th Avenue
FORA
Fort Ord, California

FIGURE

TP-3

DRAWN
PCB

JOB NUMBER
46354 3

APPROVED

DATE
11/99

REVISED DATE

Depth

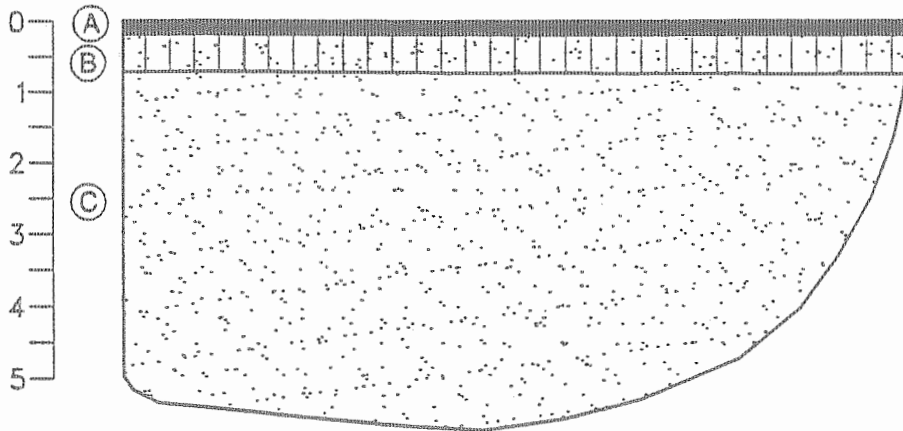

- (A) ASPHALT, 1 in.
- (B) BROWN SILTY SAND (SM) (10YR 4/3):
Loose, dry, 75% fine to coarse sand, 25% silt.
- (C) LIGHT YELLOWISH BROWN WELL GRADED SAND
(SW-SM) (10YR 6/4):
Loose, dry, 90% fine to coarse sand, 10% silt

@ 5 ft.: change to 100% fine to coarse sand

Notes:

Trenching on 9/22/99
Samples at 2.5 and 5 ft. BGS

46354004.DWG 1.0
19991112.1500

Harding Lawson Associates
Engineering and
Environmental Services

Log of Test Pit #4
California Extension
FORA
Fort Ord, California

FIGURE

TP-4

DRAWN	JOB NUMBER	APPROVED	DATE	REVISED DATE
PCB	46354 3		11/99	

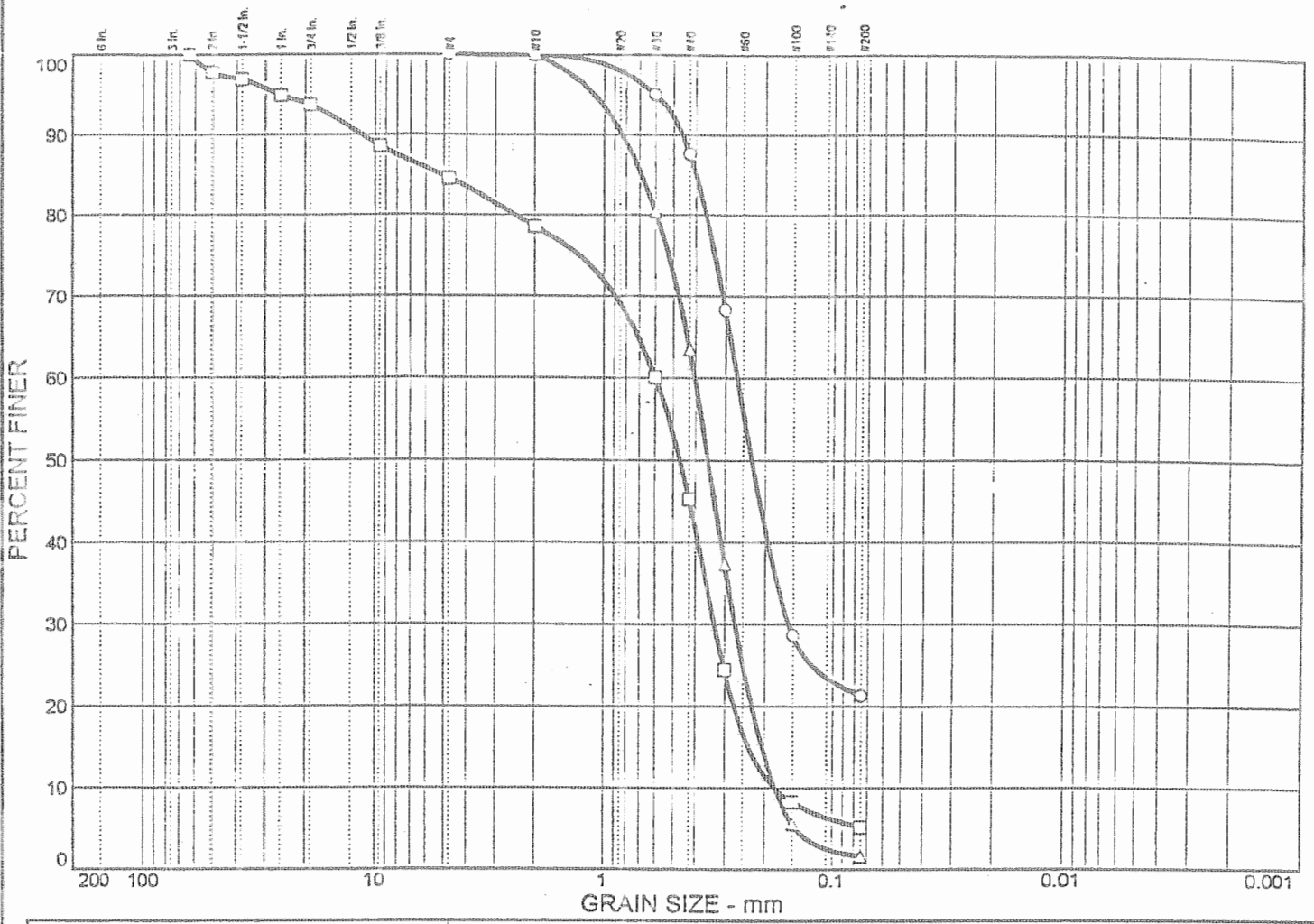

% COBBLES	% GRAVEL		% SAND			% FINES				
	CRS.	FINE	CRS.	MEDIUM	FINE	SILT	CLAY			
○	0.0	0.0	0.1	12.3	66.3	21.3				
□	0.0	6.3	6.0	33.4	40.0	5.2				
△	0.0	0.0	0.0	36.5	61.9	1.6				
×	LL	PL	D ₈₅	D ₆₀	D ₅₀	D ₃₀	D ₁₅	D ₁₀	C _c	C _u
○			0.400	0.265	0.229	0.156				
□			5.09	0.598	0.466	0.331	0.235	0.180	1.02	3.32
△			0.687	0.404	0.354	0.270	0.204	0.179	1.01	2.26

MATERIAL DESCRIPTION								USCS	AASHTO
○ orange brown silty SAND								SP-SM	
□ brown SAND w/gravel									
△ light brown SAND									

Project No. 179-161 Client: HLA	Remarks: ○ □ △
Project: 46354.1	
○ Source: 1 (TP-1) Elev./Depth: 1.5' □ Source: 2 (TP-2) Elev./Depth: 1.5' △ Source: 3 (TP-3) Elev./Depth: 1.5'	

COOPER TESTING LABORATORIES

R-VALUE TEST

JOB #: 179-161b
 DATE: 10/08/1999
 CLIENT: HLA
 SAMPLE #: 46354.1, TP2 @ 1.5'
 SOIL TYPE: brown SAND w/gravel and silt

DISH WEIGHT: 53.8
 WET: 366.5
 DRY: 355.1
 INITIAL MOSITURE: 0.0378

SPECIMEN	A	B	C	D	VALUES AT 300 EXUDATION
					R-VALUE: 71 EXP. PRESSURE: 0
EXUDATION PRESSURE (psi)	190	800	439	0	REMARKS
PREPARED WEIGHT (gm)	1200	1200	1200	1200	
FINAL WATER ADDED (gm)	80	60	70	0	
WEIGHT, SOIL & MOLD (gm)	3185	3144	3110	0	
WEIGHT, MOLD (gm)	2106	2104	2110	0	
HEIGHT (in)	2.61	2.52	2.35	0.00	
MOISTURE CONTENT (%)	10.7	9.0	9.8	0.0	
DRY DENSITY (pcf)	113.1	114.7	117.3	0.0	
EXPANSION DIAL	0	0	0	0	
EXPANSION PRESSURE (psf)	0	0	0	0	
STABILOMETER @ 2000 lb	38	28	28	0	
URNS DISPLACEMENT	3.85	3.83	3.78	0.00	
R-VALUE	68	75	76	0	
R-VALUE (corrected)	68	75	73	0	

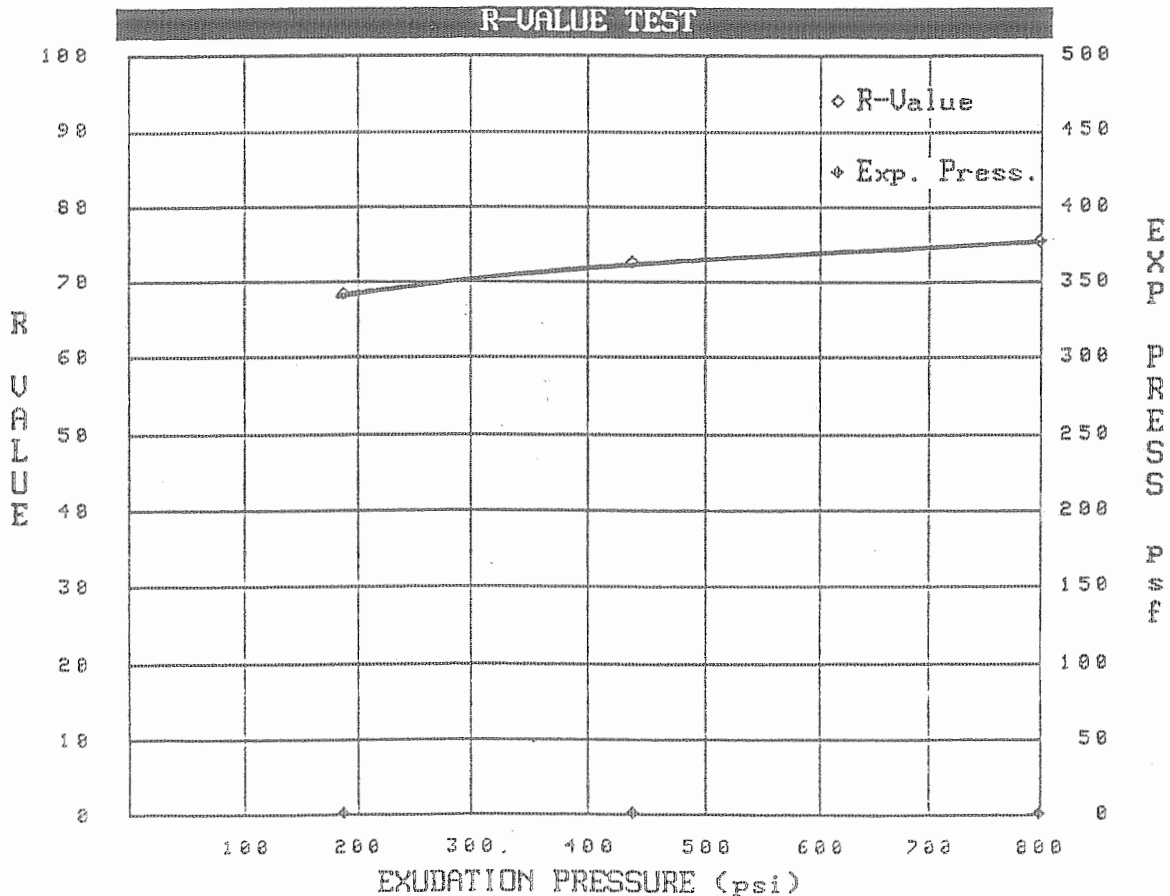

COOPER TESTING LABORATORIES

R-VALUE TEST

JOB #: 179-161a
 DATE: 10/05/1999
 CLIENT: HLA
 SAMPLE #: 46354.1, TP1 @ 1.5'
 SOIL TYPE: orange brown silty SAND

DISH WEIGHT: 43.6
 WET: 319.8
 DRY: 305.7
 INITIAL MOISTURE: 0.0538

SPECIMEN	A	B	C	D	VALUES AT 300 EXUDATION
					R-VALUE: 65 EXP. PRESSURE: 0
REMARKS					
EXUDATION PRESSURE (psi)	89	184	602	0	
PREPARED WEIGHT (gm)	1200	1200	1200	1200	
FINAL WATER ADDED (gm)	100	60	50	0	
WEIGHT, SOIL & MOLD (gm)	3163	3159	3135	0	
WEIGHT, MOLD (gm)	2070	2117	2108	0	
HEIGHT (in)	2.53	2.37	2.30	0.00	
MOISTURE CONTENT (%)	14.2	10.6	9.8	0.0	
DRY DENSITY (pcf)	114.6	120.3	123.2	0.0	
EXPANSION DIAL	0	0	0	0	
EXPANSION PRESSURE (psf)	0	0	0	0	
STABILOMETER @ 2000 lb	74	46	27	0	
TURNS DISPLACEMENT	4.57	3.85	3.65	0.00	
R-VALUE	39	62	77	62	
R-VALUE (corrected)	39	58	74	10	

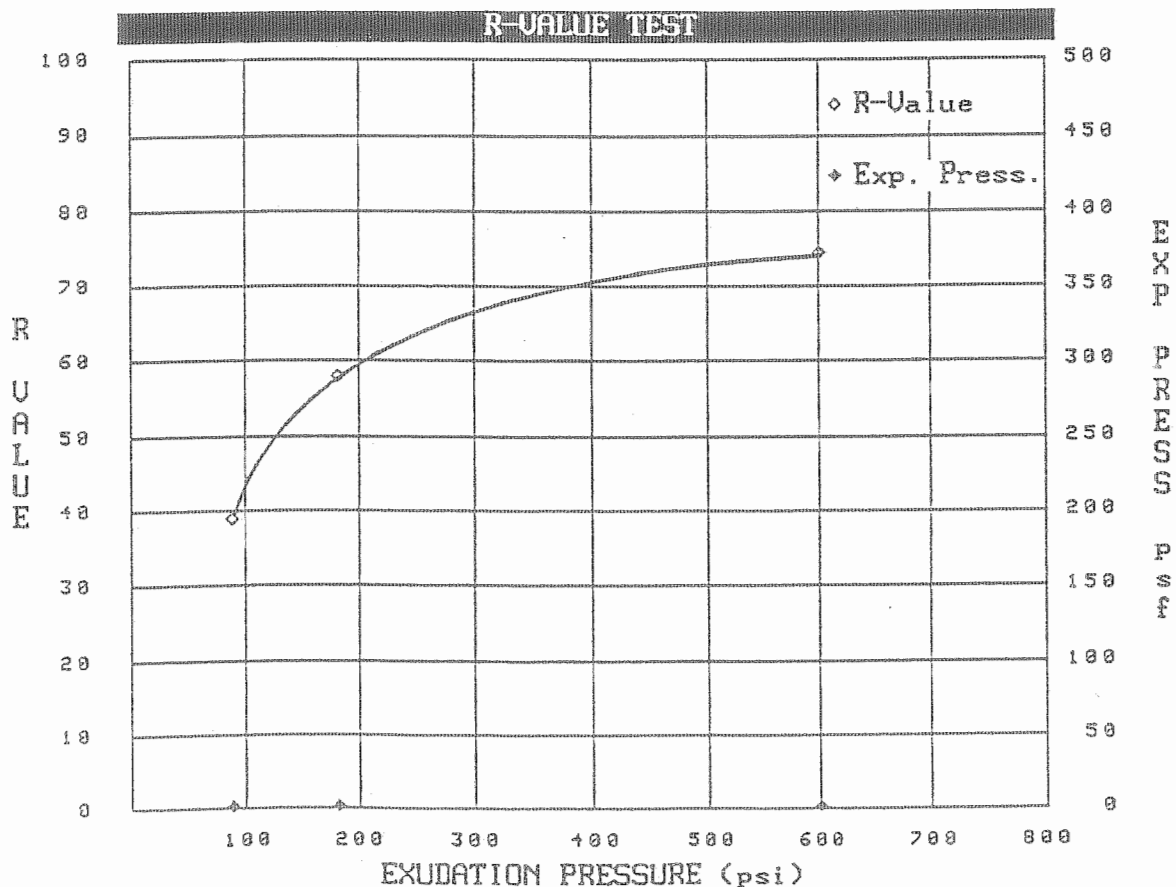

COOPER TESTING LABORATORIES

R-VALUE TEST

JOB #: 179-161
 DATE: 10/05/1999
 CLIENT: HLA
 SAMPLE #: 46354.1, TP3 @ 1.5'
 SOIL TYPE: yellow brown silty SAND

DISH WEIGHT: 53.8
 WET: 381.8
 DRY: 365.9
 INITIAL MOISTURE: 0.0509

SPECIMEN	A	B	C	D	VALUES AT 300 EXUDATION
					R-VALUE: 73 EXP. PRESSURE: 0
EXUDATION PRESSURE (psi)	456	76	350	141	REMARKS
PREPARED WEIGHT (gm)	1200	1200	1200	1200	
FINAL WATER ADDED (gm)	90	110	100	105	
WEIGHT, SOIL & MOLD (gm)	3073	3085	3057	3104	
WEIGHT, MOLD (gm)	2125	2139	2131	2138	
HEIGHT (in)	2.42	2.46	2.42	2.53	
MOISTURE CONTENT (%)	13.0	14.7	13.9	14.3	
DRY DENSITY (pcf)	105.0	101.5	101.8	101.2	
EXPANSION DIAL	0	0	0	0	
EXPANSION PRESSURE (psf)	0	0	0	0	
STABILOMETER @ 2000 lb	28	35	32	34	
TURNS DISPLACEMENT	3.43	3.52	3.28	3.57	
R-VALUE	77	72	75	72	
R-VALUE (corrected)	76	70	74	72	

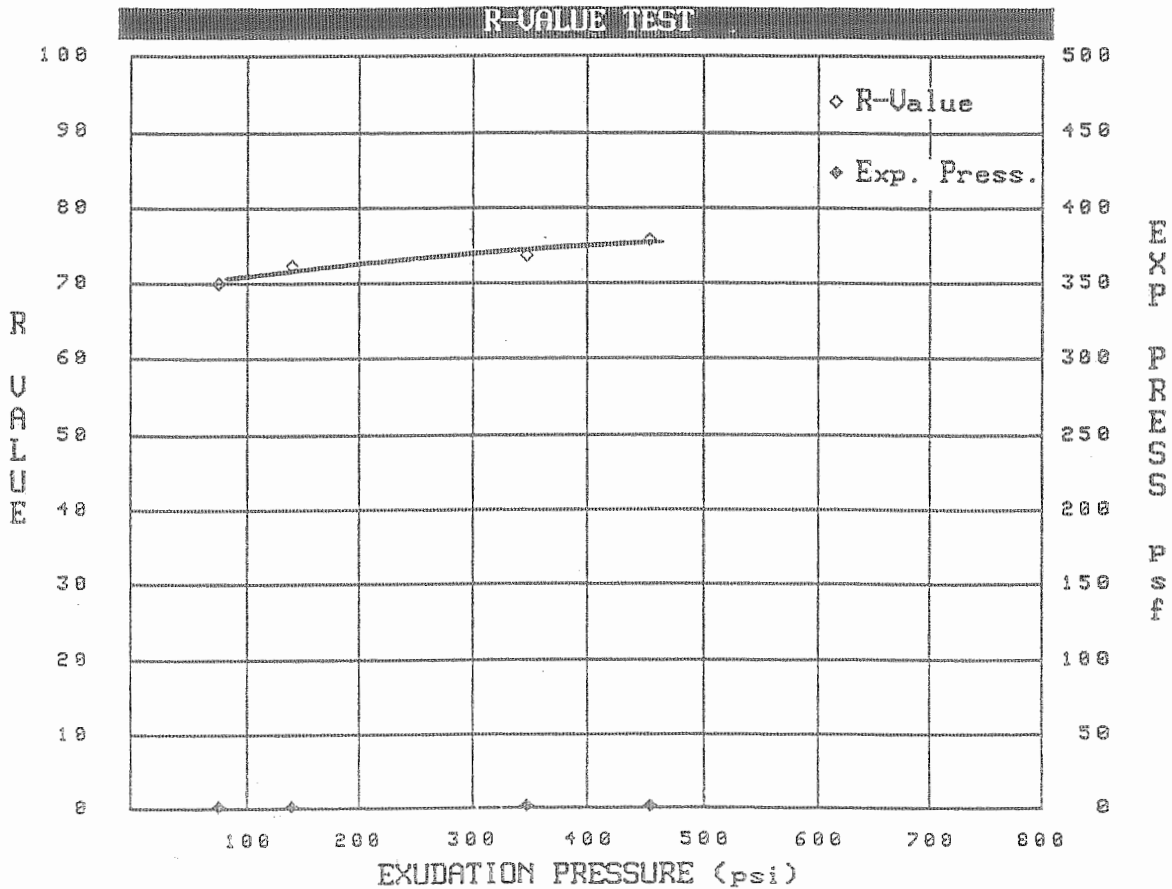

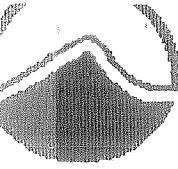

1343 Redwood Way
Petaluma, CA 94954

(707) 795-9605/FAX 795-9384

Environmental
Technical
Services

Testing & Monitoring
Analytical Labs
Technical Support

Serving people and the environment so that both benefit.

COMPANY: Harding Lawson Associates, 90 digital Drive, Novato, CA 94949
ATTN: Joe Phaby
PROJECT NAME: Fort Ord
Monterey, California
JOB NUMBER: 46354.1

DATE COLLECTED: 9/22/99
DATE RECEIVED: 9/28/99
DATE of COMPLETION: 10/12/99

ANALYST(S): C. Lawrence, J. Garibay
SUPERVISOR: D. Jacobson, LAB DIRECTOR, G.S. Conrad PhD

LAB SAMPLE NUMBER	SAMPLE ID	DESCRIPTION of SOIL and/or SEDIMENT	SOIL pH -log[H+]	SINGLE POINT RESISTIVITY ohm-cm	ELECTRICAL CONDUCTIVITY µmhos/cm	SULFATE SO4 ppm	CHLORIDE Cl ppm
99-0361	9938EG1	TP-1 @ 2.5'	5.94	8620	[116]	72	54
99-0362	9938CE2	TP-2 @ 2.5'	4.94	8850	[113]	51	60

Method	Detection	Limits ---->	---	1	0.1	1	1
LAB SAMPLE NUMBER	SAMPLE ID	DESCRIPTION of SOIL and/or SEDIMENT	SALINITY ECe mmhos/cm	SOLUBLE SULFIDES (S=) ppm	SOLUBLE CYANIDES (CN=) ppm	REDOX mV	PERCENT MOISTURE %

Method	Detection	Limits ---->	---	0.1	0.1	1	0.1
--------	-----------	--------------	-----	-----	-----	---	-----

COMMENTS

While the resistivities were approaching 10,000 ohm-cm in both samples, both pHs were very acidic; chloride & sulfate levels were low in both. The CalTrans times to perforation would be as follows: for 9938EG and 18 ga it is 21.6 yrs, & for 12 ga it would be 47.6 yrs; and for 9938CE is at 18.1 yrs, and for 12 ga it would be 39.8 yrs. These times are not very good, are pretty decent, and might be characterized as "average" to good. The sulfate and chloride concentrations are not high enough to be of any concern as they relate to potential impact on grouts, mortars and cements, and on ferrous reinforcement in construction materials. Finally, the times to perforation would be dramatically increased by liming these soils to the 7.5-8 pH range especially since acidity is their only problem - resistivities are very high, much higher than typical which accounts for good perf times; (e.g. 18 ga times would increase to about 60+ years for the two).

NOTES: Methods are from the following sources: extractions by Cal Trans protocols as per Method 417 (SO4), 422 (Cl), 32/643 (pH & resistivity); and/or by ASTM Vol. 4.08 & ASTM Vol. 11.01 (=EPA Meth Chem Anal, or Standard Methods); ASTM G 51; Specific Cond. - ASTM D 1125; resistivity - ASTM G 57; redox - Pt probe/ISE; sulfate - extraction Title 22, ion ASTM D 516 (=EPA 375.4); chloride - extraction Title 22, detection ASTM D 512 (=EPA 325.3); sulfides - extraction 22, detection EPA 376.2 (=SMEWW 4500-S D); cyanides - extraction Title 22, detection ASTM D 4374 (=EPA 335.2).

Kleinfelder Inc. 2005¹

¹ Please see Figure 5 for full citation.

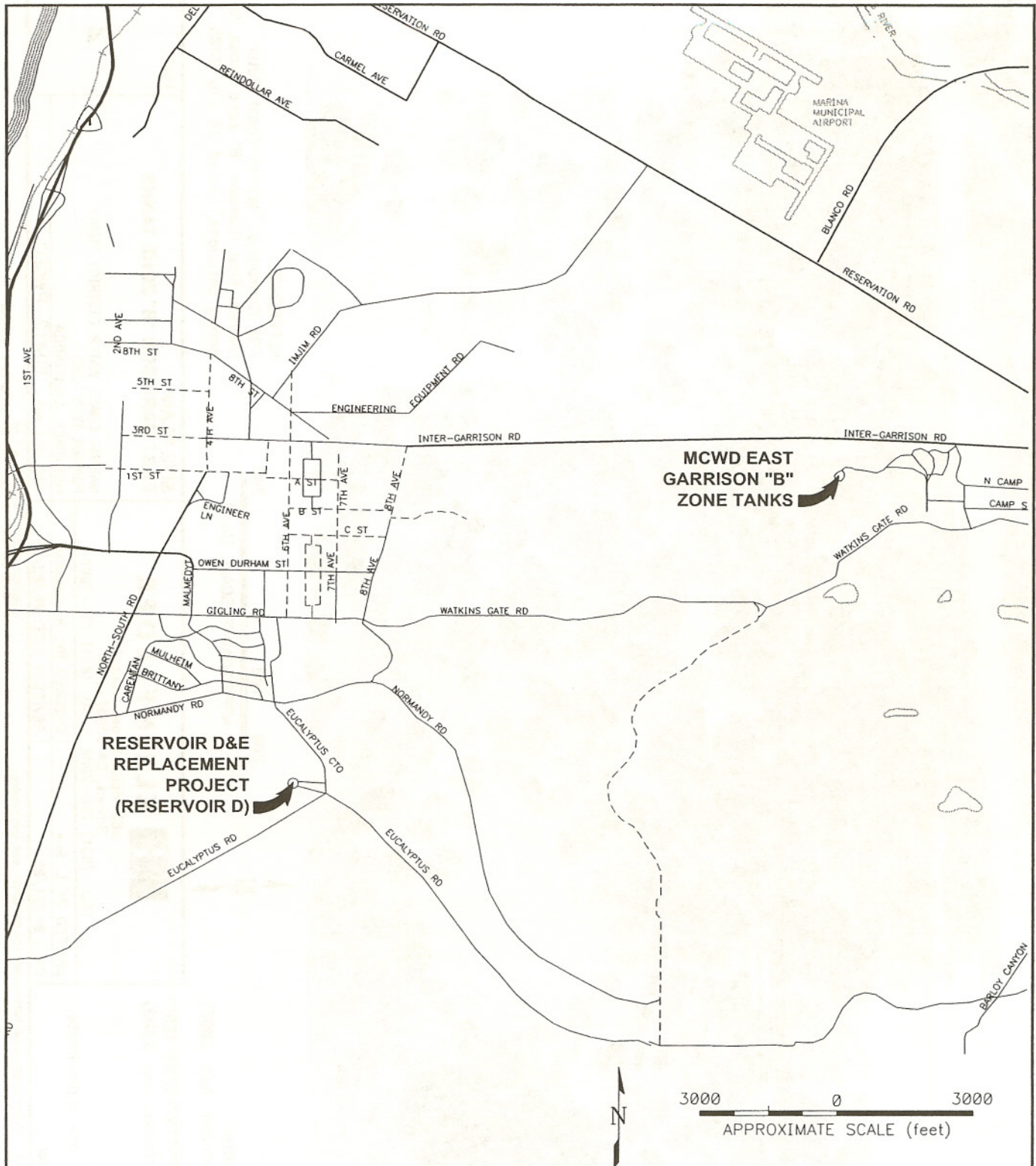

© by Kleinfelder Inc., 2005



365 Victor Street, Suite L
 Salinas, CA 93907-2024
 TEL: (831) 755-7900 FAX: (831) 755-7909

SITE VICINITY MAP

MARINA COAST WATER DISTRICT TANKS
 FORMER FORT ORD
 MONTEREY, CALIFORNIA
 PROJECT NO. 59012-PWGE0

PLATE

1

DRAFTED BY: L. Sue

CHECKED BY: R. Hasseler

DATE: 08/26/05

REVISION DATE:

ATTACHED XREFS: XRef: TB_A-port

ATTACHED IMAGES:

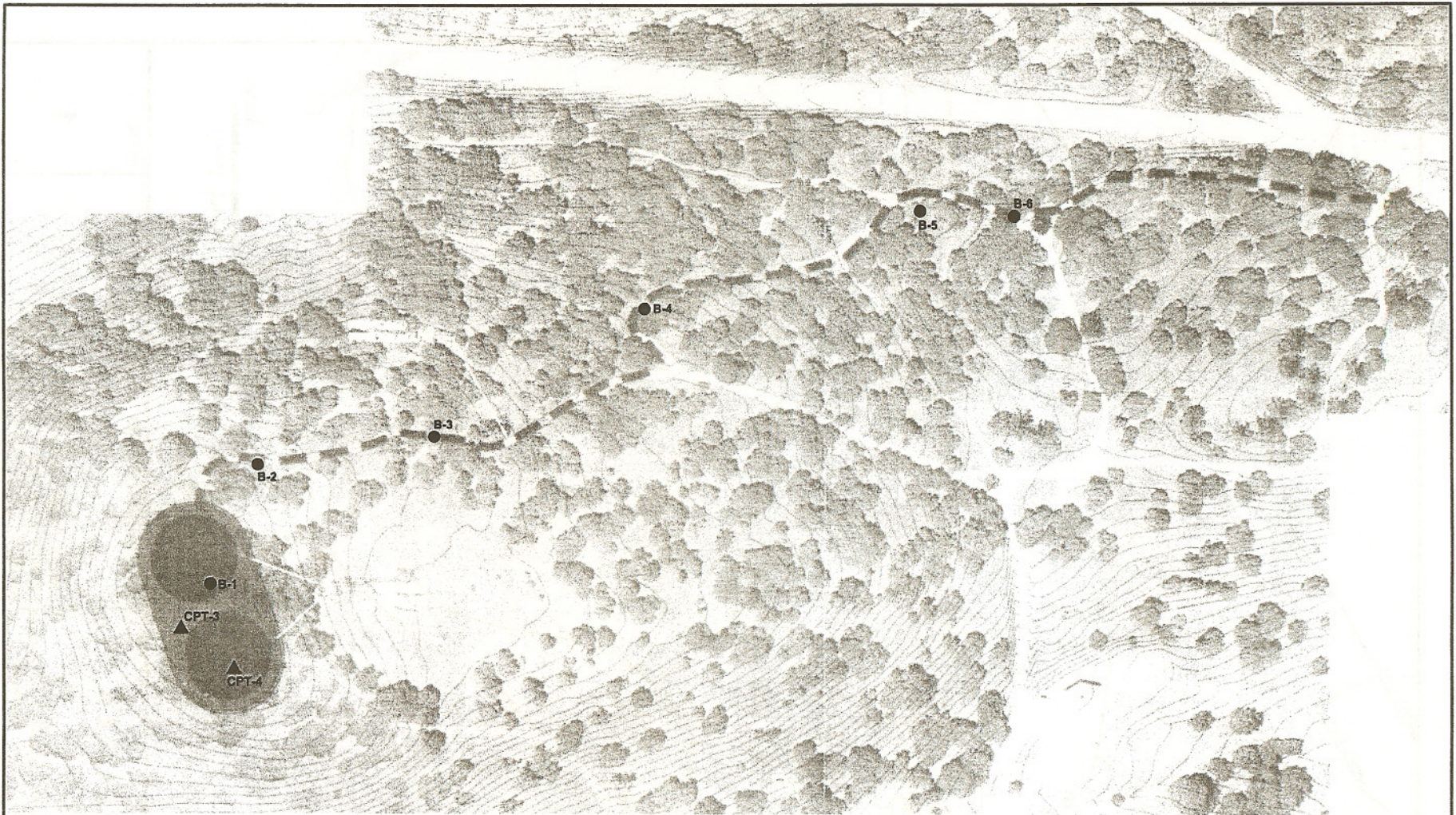

LEGEND

- SOIL BORING
(by Kleinfelder, Aug. 2005)
- ▲ CONE PENETROMETER TEST
(by Kleinfelder, Aug. 2005)

NOTE: Locations are approximate.

© by Kleinfelder Inc., 2005

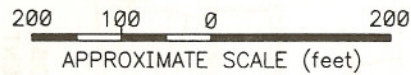

REFERENCE:

RBF Consulting, "Marina Coast Water District, East Garrison 'B' Zone Tanks, Soil Boring Locations," dated 28 July 2005.

 KLEINFELDER 365 Victor Street, Suite L Salinas, CA 93907-2024 TEL: (831) 755-7900 FAX: (831) 755-7909		SITE PLAN: EAST GARRISON "B" ZONE TANKS	PLATE <h1 style="font-size: 2em;">2</h1>
DRAFTED BY: L. Sue		CHECKED BY: R. Hasseler	
DATE: 09/21/05		REVISION DATE: 09/02/05	
		MARINA COAST WATER DISTRICT TANKS FORMER FORT ORD MONTEREY, CALIFORNIA PROJECT NO. 59012-PWGEO	



LEGEND

- SOIL BORING
(by Kleinfelder, Aug. 2005)
- ▲ CONE PENETROMETER TEST
(by Kleinfelder, Aug. 2005)

NOTE: Locations are approximate.

© by Kleinfelder Inc., 2005

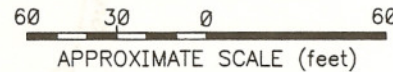

REFERENCE:

RBF Consulting, "Reservoir D Site Boring Locations," dated 15 July 2005.

 KLEINFELDER 365 Victor Street, Suite L Salinas, CA 93907-2024 TEL: (831) 755-7900 FAX: (831) 755-7909		SITE PLAN: RESERVOIR D SITE	PLATE 3
DRAFTED BY: L. Sue DATE: 09/21/05	CHECKED BY: R. Hasseler REVISION DATE:	MARINA COAST WATER DISTRICT TANKS FORMER FORT ORD MONTEREY, CALIFORNIA PROJECT NO. 59012-PWGEO	

UNIFIED SOIL CLASSIFICATION SYSTEM

MAJOR DIVISIONS		LTR	ID	DESCRIPTION	MAJOR DIVISIONS		LTR	ID	DESCRIPTION
COARSE GRAINED SOILS	GRAVEL AND GRAVELLY		GW	Well-graded gravels or gravel with sand, little or no fines.	FINE GRAINED SOILS	SILTS AND CLAYS		ML	Inorganic silts and very fine sands, rock flour or clayey silts with slight plasticity.
			GP	Poorly-graded gravels or gravel with sand, little or no fines.				CL	Inorganic lean clays of low to medium plasticity, gravelly clays, sandy clays, silty clays.
			GM	Silty gravels, silty gravel with sand mixture.				OL	Organic silts and organic silt-clays of low plasticity.
			GC	Clayey gravels, clayey gravel with sand mixture.			MH	Inorganic elastic silts, micaceous or diatomaceous or silty soils.	
	SAND AND SANDY		SW	Well-graded sands or gravelly sands, little or no fines.		SILTS AND CLAYS		CH	Inorganic fat clays (high plasticity).
			SP	Poorly-graded sands or gravelly sands, little or no fines.				OH	Organic clays of medium high to high plasticity.
			SM	Silty sand.					
			SC	Clayey sand.		HIGHLY ORGANIC SOILS		Pt	Peat and other highly organic soils.



Standard Penetration Split Spoon Sampler 2.0 inch O.D., 1.4 inch I.D.

Modified California Sampler 2.5 inch O.D., 2.0 inch I.D.

Bulk Sample

California Sampler, 3.0 inch O.D., 2.5 inch I.D.

Shelby Tube 3.0 inch O.D.



Approximate water level first observed in boring. Time recorded in reference to a 24 hour clock.



Approximate water level observed in boring following drilling

PEN Pocket Penetrometer reading, in tsf
 TV:Su Torvane shear strength, in ksf

LL	LIQUID LIMIT	TX	TRIAxIAL SHEAR
PI	PLASTICITY INDEX	CONSOL	CONSOLIDATION
%-#200	SIEVE ANALYSIS (#200 SCREEN)	R-Value	RESISTANCE VALUE
DS	DIRECT SHEAR	SE	SAND EQUIVALENT
C	COHESION (PSF)	EI	EXPANSION INDEX
PHI	FRICITION ANGLE	FS	FREE SWELL (U.S.B.R.)

Notes: Blow counts represent the number of blows a 140-pound hammer falling 30 inches required to drive a sampler through the last 12 inches of an 18 inch penetration, unless otherwise noted.

The lines separating strata on the logs represent approximate boundaries only. The actual transition may be gradual. No warranty is provided as to the continuity of soil strata between borings. Logs represent the soil section observed at the boring location on the date of drilling only.



BORING LOG LEGEND

MARINA COAST WATER DISTRICT TANKS
 FORMER FORT ORD
 MONTEREY, CALIFORNIA

PLATE

A-1

PROJECT NO. 59012-PWGE0

Date Completed: 8/5/05

Drilling method: 8" Hollow Stem Auger

Logged By: P. Llewellyn

Hammer Wt: 140 lbs., 30" drop

Total Depth: 100.0 ft

Notes: Sand

Depth, ft	FIELD		LABORATORY				Pen, tsf	DESCRIPTION
	Sample	Blows/ft	Dry Density pct	Moisture Content %	Compress. Strength tsf	Other Tests		
8						Passing #200 = 11%	POORLY GRADED SAND with SILT (SM) - brown, damp, loose, fine grained sand - dark yellowish-brown, moist	
5								
10							POORLY GRADED SAND (SP) - yellowish-brown, moist, loose - medium dense - brownish-yellow, fine grained sand	
15								
20								
25						Passing #200 = 2%		

L:\0005\PROJECTS\59012\59012.GPJ



KLEINFELDER

PROJECT NO. 59012-PWGEO

LOG OF BORING NO. B-7

MARINA COAST WATER DISTRICT TANKS
FORMER FORT ORD
MONTEREY, CALIFORNIA

PLATE

A-8

9/21/05 2:43:05 PM

Depth, ft	FIELD		LABORATORY				Pen, tsf	DESCRIPTION (Continued from previous plate)
	Sample	Blows/ft	Dry Density pcf	Moisture Content %	Compress. Strength tsf	Other Tests		
30	31							- dense
35	40							
40	46				Passing #200 =32%			SILTY SAND (SM) - grayish-brown, moist, dense, fine grained sand
45	36							POORLY GRADED SAND with SILT (SP-SM) - yellowish-brown, moist, dense, fine grained sand
50	62				Passing #200 =8%			- very dense
55	61							

L:\2005\05\PROJECTS\59012\59012.GPJ



PROJECT NO. 59012-PWGEO

LOG OF BORING NO. B-7

MARINA COAST WATER DISTRICT TANKS
FORMER FORT ORD
MONTEREY, CALIFORNIA

PLATE

A-8
(cont'd)

9/21/05 2:43:06 PM

Depth, ft	FIELD		LABORATORY				Pen, tsf	DESCRIPTION
	Sample	Blows/ft	Dry Density pct	Moisture Content %	Compress. Strength tsf	Other Tests		
60	59							- dark brown, very dense
65	62					Passing #200 = 11%		
70	56							POORLY GRADED SAND (SP) - yellowish-brown, moist, very dense, fine grained sand
75	61							
80	59							- brownish-yellow
85	40					Passing #200 = 5%		POORLY GRADED SAND with SILT (SP-SM) -brownish-yellow, moist, dense, fine grained sand

L:\2005\PROJECTS\59012\59012.GPJ



KLEINFELDER

PROJECT NO. 59012-PWGeo

LOG OF BORING NO. B-7

MARINA COAST WATER DISTRICT TANKS
FORMER FORT ORD
MONTEREY, CALIFORNIA

PLATE

A-8
(cont'd)

9/21/05 2:43:07 PM

Depth, ft	FIELD		LABORATORY				Pen, tsf	DESCRIPTION
	Sample	Blows/ft	Dry Density pcf	Moisture Content %	Compress. Strength tsf	Other Tests		
90	51						(Continued from previous plate) - very dense	
95	59							
100	53							
105							Boring terminated at 100 feet, below ground surface. No free water encountered. Boring backfilled with drilling spoils.	
110								
115								

L:\2005\PROJECTS\59012\59012.GPJ



KLEINFELDER

PROJECT NO. 59012-PWGEO

LOG OF BORING NO. B-7

MARINA COAST WATER DISTRICT TANKS
 FORMER FORT ORD
 MONTEREY, CALIFORNIA

PLATE

A-8
 (cont'd)

9/21/05 2:43:06 PM

Date Completed: 8/5/05

Drilling method: 8" Hollow Stem Auger

Logged By: P. Llewellyn

Hammer Wt: 140 lbs., 30" drop

Total Depth: 20.0 ft

Notes: Sand

Depth, ft	FIELD		LABORATORY				Pen, tsf	DESCRIPTION
	Sample	Blows/ft	Dry Density pcf	Moisture Content %	Compress. Strength tsf	Other Tests		
							Surface Elevation: Estimated feet (MSL)	
11							SILTY SAND (SM) - brown, damp, medium dense, fine grained sand	
5 12							POORLY GRADED SAND with SILT (SP-SM) - light yellowish-brown, medium dense	
10 17				8.0				
15 18							POORLY GRADED SAND (SP) - yellowish-brown, moist, medium dense, fine grained sand	
20 22							Boring terminated at 20 feet, below ground surface. No free water encountered. Boring backfilled with drilling spoils.	
25								

L:\2005\05\PROJECTS\59012\59012.GPJ



LOG OF BORING NO. B-8

PLATE

MARINA COAST WATER DISTRICT TANKS
FORMER FORT ORD
MONTEREY, CALIFORNIA

A-9

PROJECT NO. 59012-PWGEO

9/21/05 2:43:11 PM

PROJECT: Marina Coast - Water Tanks

LOCATION: Seaside CA

CPT-1

CPT-2

CPT-3

CPT-4

Qc (tsf)

Qc (tsf)

Qc (tsf)

Qc (tsf)

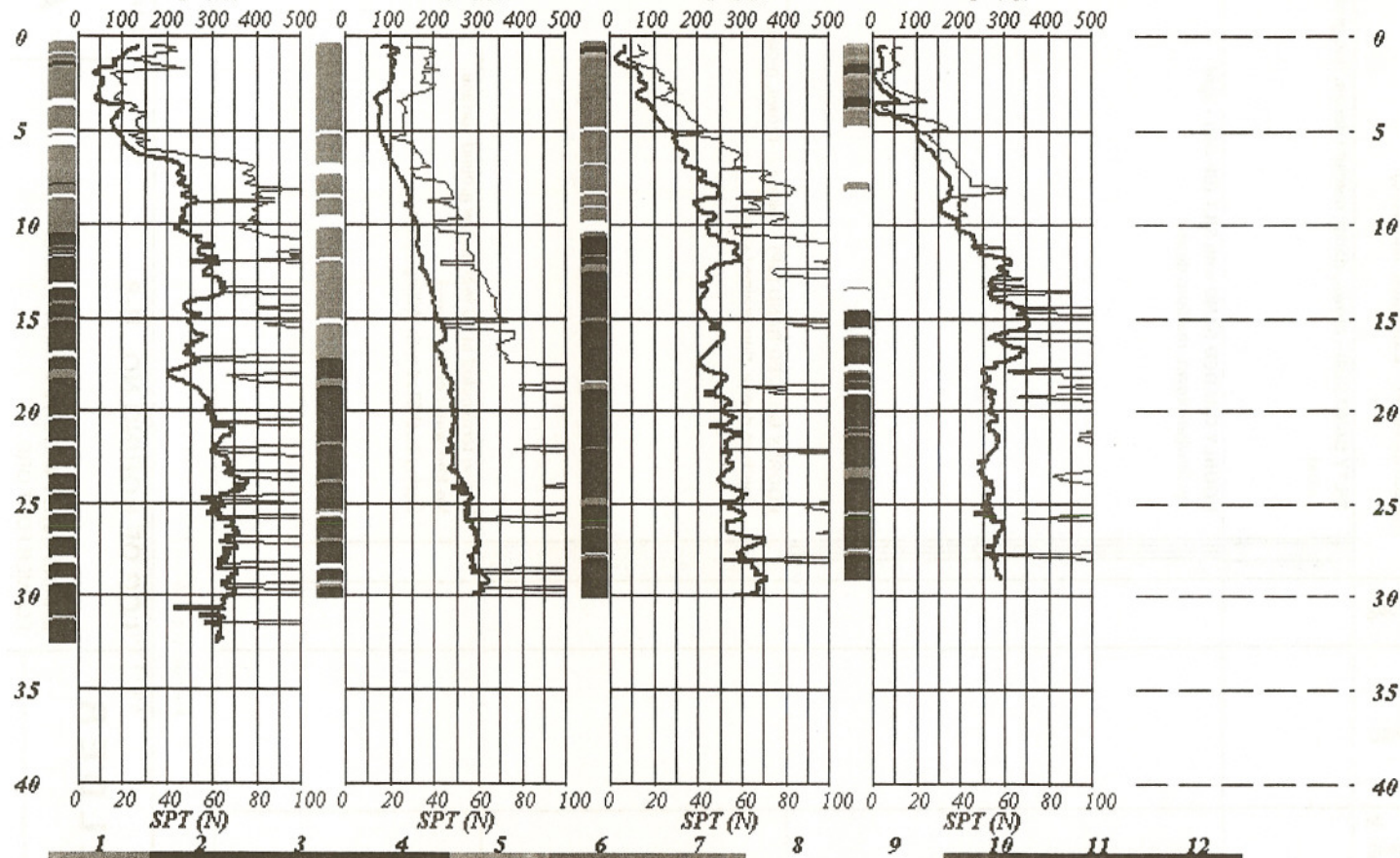

John Sarmiento & Associates **Cone Penetration Services** **Graphics Copyright 1996**

PROJECT: Marina Coast - Water Tanks

LOCATION: Seaside CA

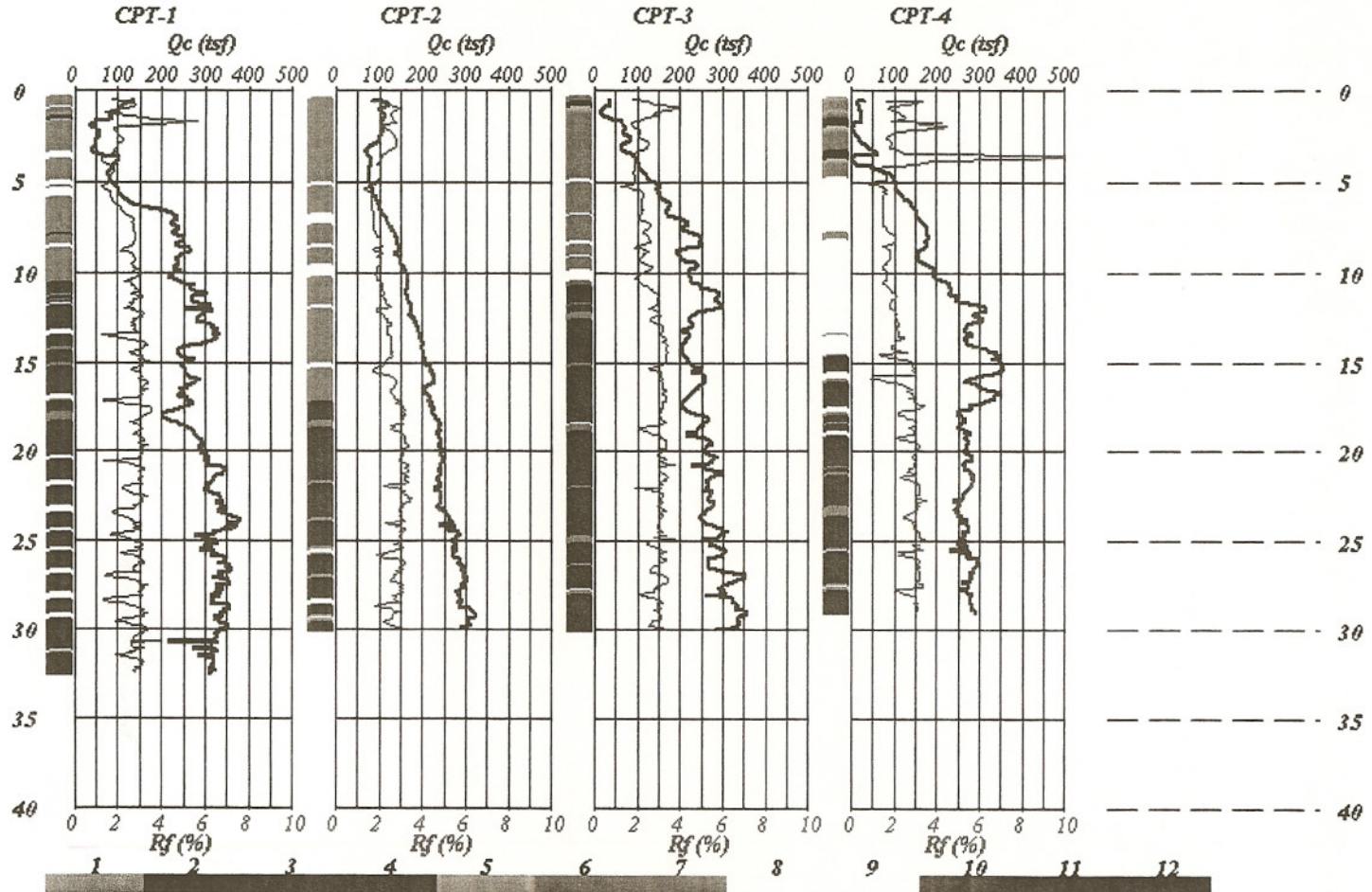

1 Sensitive 2 Peat 3 CLAY 4 Clay/Silt 5 SILT 6 Silty Sand 7 SAND 8 Grv Sand 9 Over Con/Cemented 10 11 12
 John Sarmiento & Associates Cone Penetration Services Graphics Copyright 1996

SIEVE ANALYSIS

KLEINFELDER, INC.

Project Marina Coast WD Tank
Boring B7-1

Depth, ft 1'

Proj. No. 59012/pwgeo Lab No. 5298 Tested by NA
Description Poorly Graded Sand With Silt (SP-SM)

Test date 8/23/2005

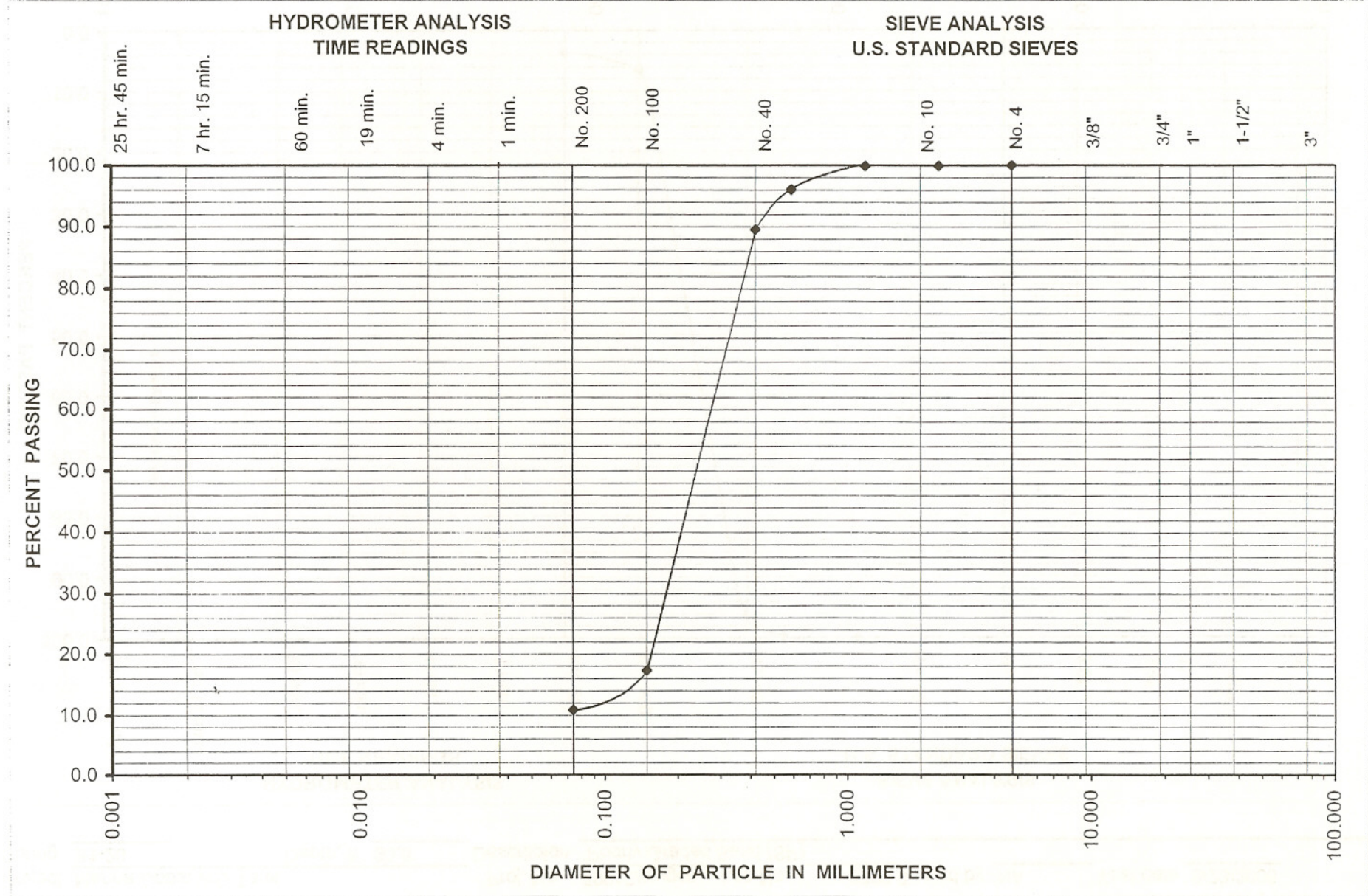

SIEVE ANALYSIS

KLEINFELDER, INC.

Project Marina Coast WD Tank

Proj. No. 59012/pwgeo

Lab No. 5298

Tested by NA

Test date 8/23/2005

Boring B7-6

Depth, ft 23.5'

Description Poorly Graded Sand (SP)

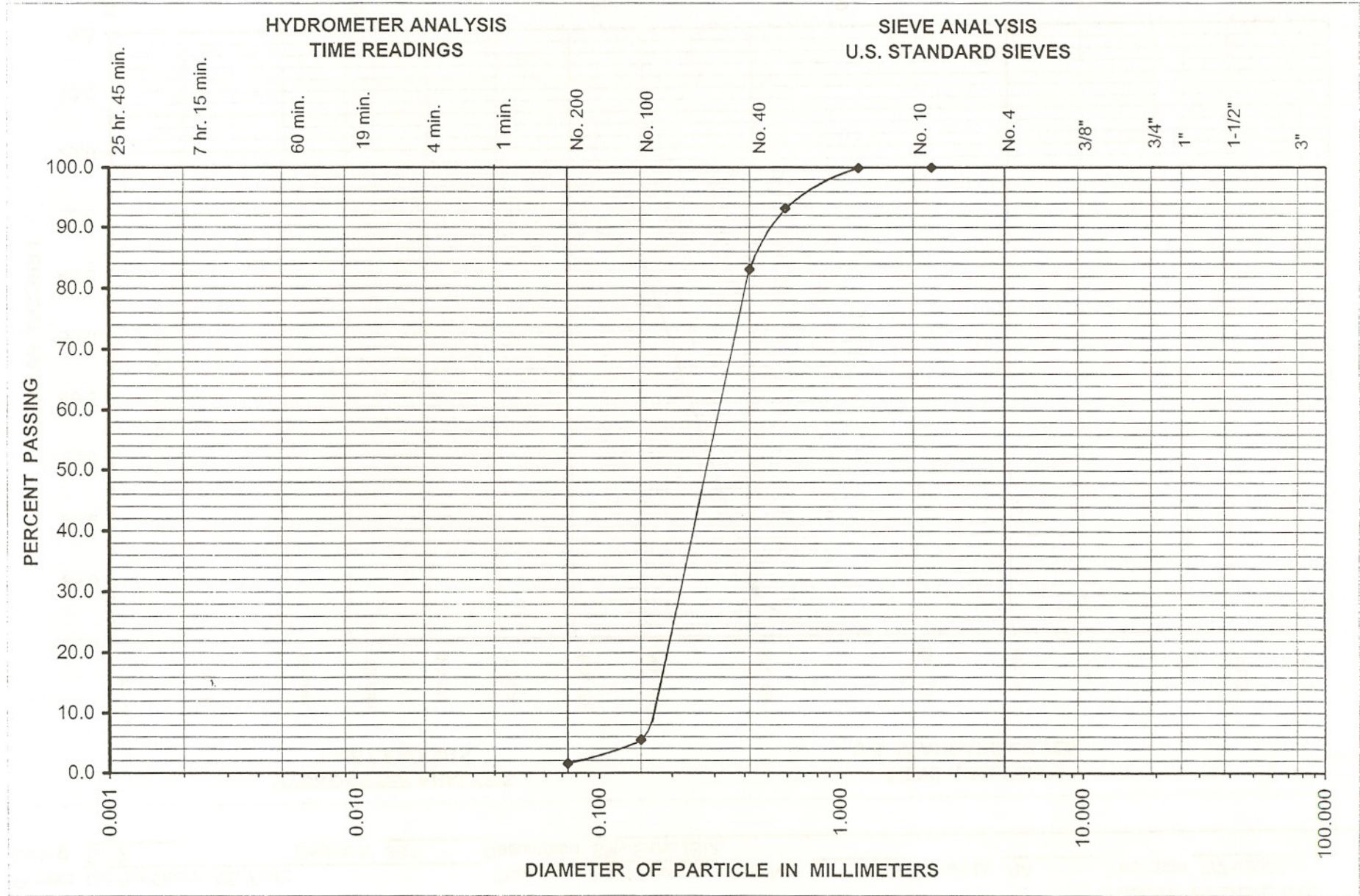

SIEVE ANALYSIS

KLEINFELDER, INC.

Project Marina Coast WD Tank

Proj. No. 59012/pwgeo

Lab No. 5298

Tested by NA

Test date 8/23/2005

Boring B7-9

Depth, ft 38.5'

Description Silty Sand (SM)

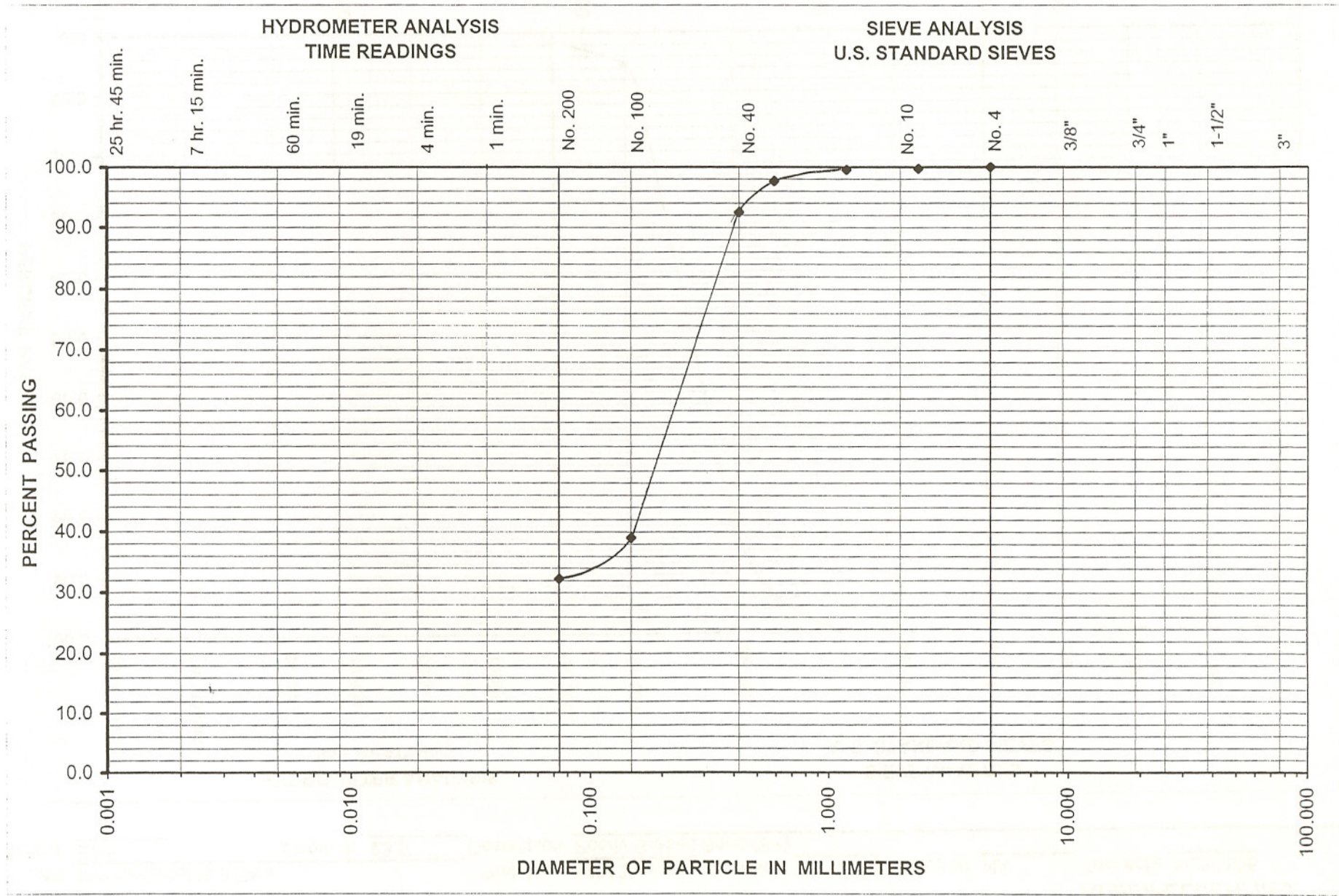

SIEVE ANALYSIS

KLEINFELDER, INC.

Project Marina Coast WD Tank

Proj. No. 59012/pwgeo

Lab No. 5298 Tested by NA

Test date 8/23/2005

Boring B7-11

Depth, ft 48.5'

Description Poorly Graded Sand With Silt (SP-SM)

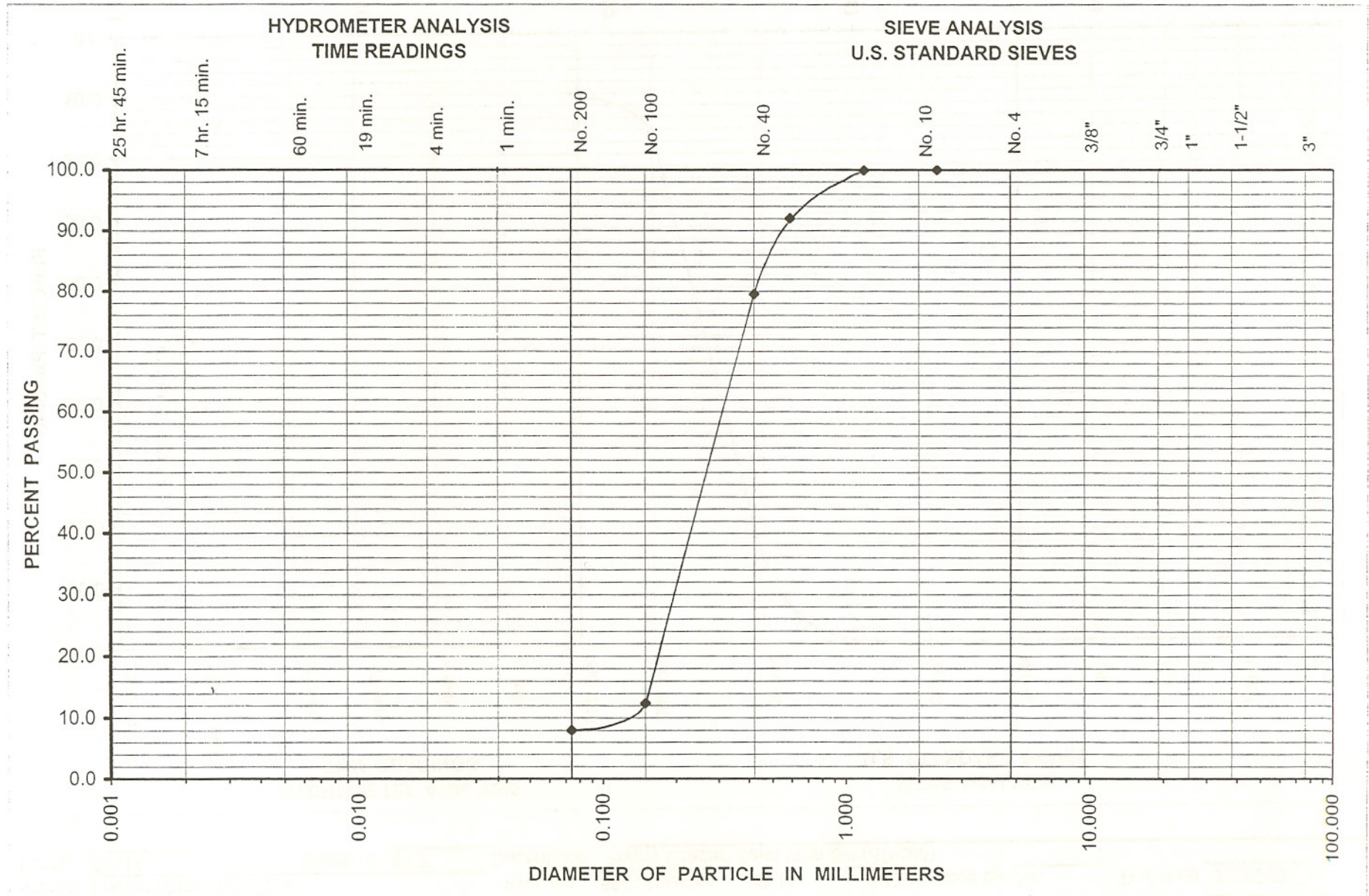

SIEVE ANALYSIS

KLEINFELDER, INC.

Project Marina Coast WD Tank

Proj. No. 59012/pwgeo

Lab No. 5298

Tested by NA

Test date 8/23/2005

Boring B7-14

Depth, ft 63.5'

Description Poorly Graded Sand With Silt (SP-SM)

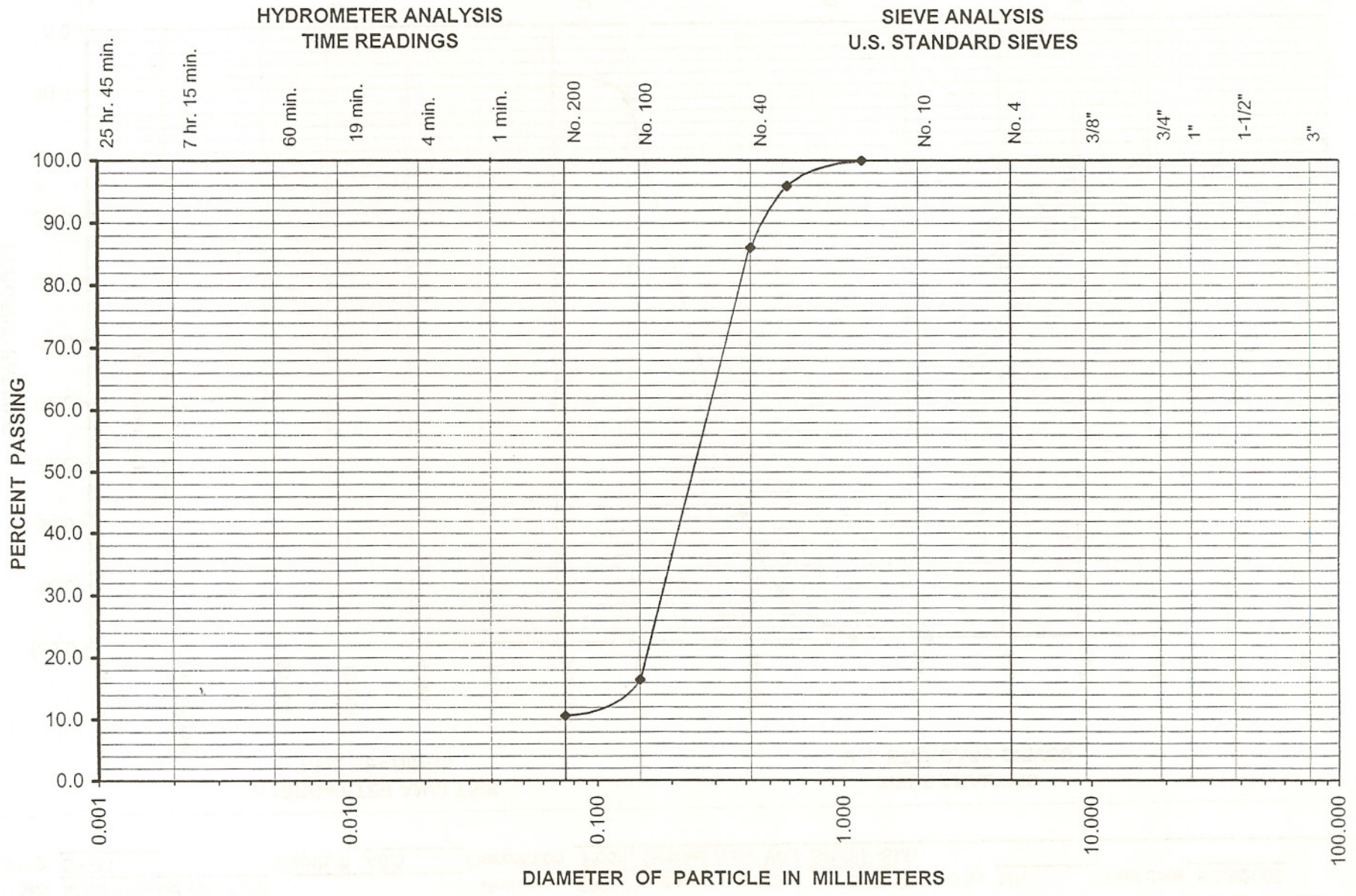

SIEVE ANALYSIS

KLEINFELDER, INC.

Project Marina Coast WD Tank

Proj. No. 59012/pwgeo

Lab No. 5298 Tested by NA

Test date 8/23/2005

Boring B7-18

Depth, ft 83.5'

Description Poorly Graded Sand With Silt (SP-SM)

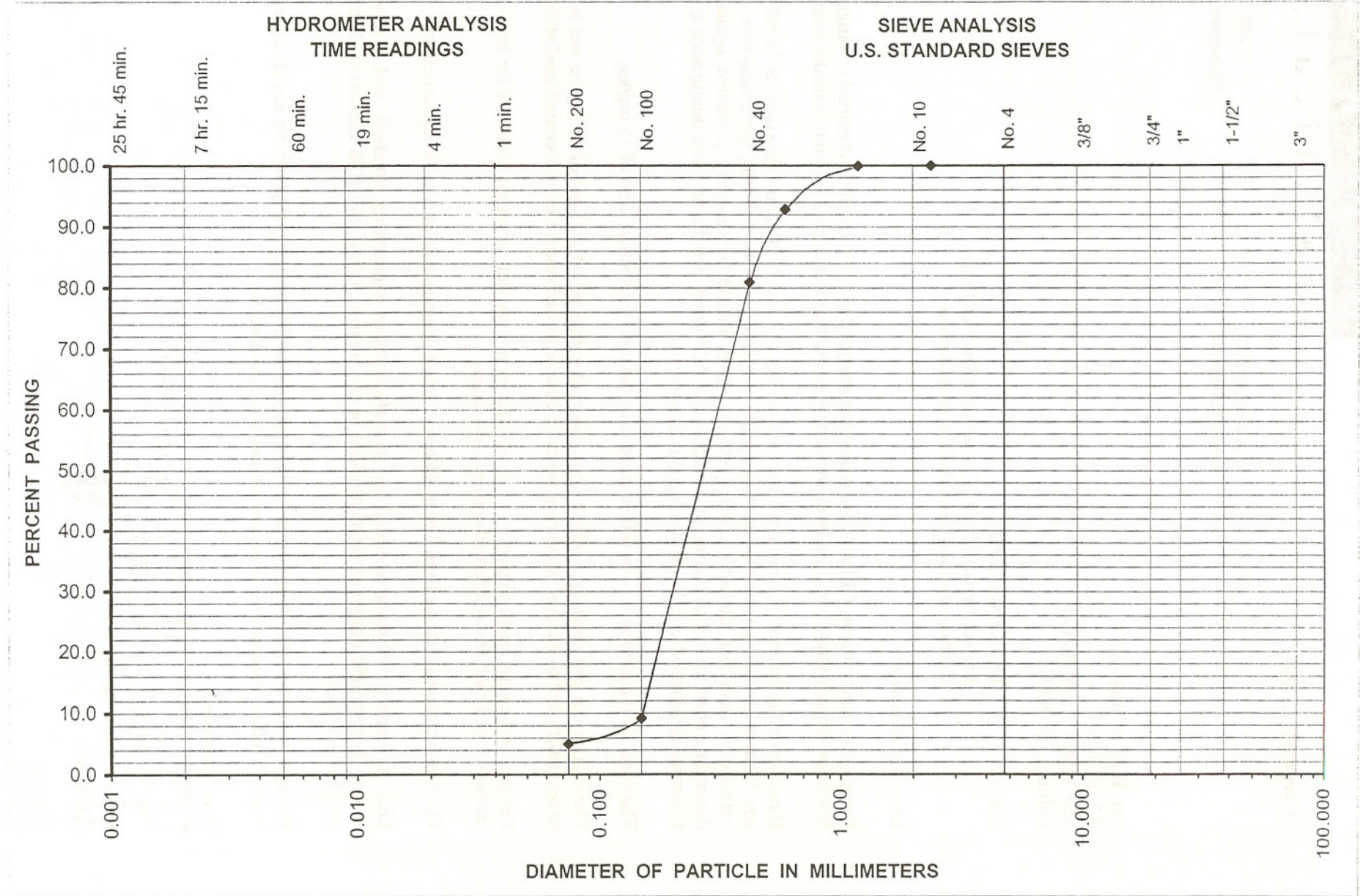

1 September, 2005

Job No.0508155
Cust. No.11454

3942-A Valley Avenue
Pleasanton, CA 94566-4715
Tel: 925.462.2771
Fax: 925.462.2775

Mr. Robert Hasseler
Kleinfelder
365 Victor Street, Suite L
Salinas, CA 93907

Subject: Project No.: 59012
Project Name: Marina Coast Water District Tanks
Corrosivity Analysis – ASTM Test Methods

Dear Mr. Hasseler:

Pursuant to your request, CERCO Analytical has analyzed the soil samples submitted on August 19, 2005. Based on the analytical results, a brief corrosivity evaluation is enclosed for your consideration.

Based upon the resistivity measurements, Samples No.001 and No.002 are classified as "mildly corrosive" and Sample No.003 is classified as "negligibly corrosive". All buried iron, steel, cast iron, ductile iron, galvanized steel and dielectric coated steel or iron should be properly protected against corrosion depending upon the critical nature of the structure. All buried metallic pressure piping such as ductile iron firewater pipelines should be protected against corrosion.

The chloride ion concentrations reflect none detected with a detection limit of 15 mg/kg.

The sulfate ion concentrations reflect none detected with a detection limit of 15 mg/kg and is determined to be insufficient to damage reinforced concrete structures and cement mortar-coated steel at this location.

The pH of the soils range from 6.9 to 7.3 which does not present corrosion problems for buried iron, steel, mortar-coated steel and reinforced concrete structures.

The redox potentials range from 430 to 450-mV, which is indicative of aerobic soil conditions.

This corrosivity evaluation is based on general corrosion engineering standards and is non-specific in nature. For specific design recommendations or consultation, please call JDH Corrosion Consultants, Inc. at (925) 927-6630.

We appreciate the opportunity of working with you on this project. If you have any questions, or if you require further information, please do not hesitate to contact us.

Very truly yours,

CERCO ANALYTICAL, INC.

J. Darby Howard, Jr., P.E.
President

JDH/jdl
Enclosure

CERCO Analytical, Inc.

3942-A Valley Avenue, Pleasanton, CA 94566-4715 (925) 462-2771 Fax (925) 462-2775

FINAL RESULTS

Client: Kleinfelder
 Client's Project No.: 59012
 Client's Project Name: Marina Coast Water District Tanks
 Authorization: Signed Chain of Custody

Date Sampled: 08/04-05/05
 Date Received: 19-Aug-2005
 Date of Report: 31-Aug-2005
 Matrix: Soil

Job/Sample No.	Sample I.D.	Redox (mV)	pH	Conductivity (umhos/cm)*	Resistivity (100% Saturation) (ohms-cm)	Sulfide (mg/kg)*	Chloride (mg/kg)*	Sulfate (mg/kg)*
0508155-001	B1-2 @ 5'	440	7.2	-	18,000	-	N.D.	N.D.
0508155-002	B4-2 @ 5'	450	7.3	-	10,000	-	N.D.	N.D.
0508155-003	B7-2 @ 5'	430	6.9	-	>80,000	-	N.D.	N.D.

Method:	ASTM D1498	ASTM D4972	ASTM D1125M	ASTM G57	ASTM D4658M	ASTM D4327	ASTM D4327
Detection Limit:	-	-	10	-	50	15	15
Date Analyzed:	29-Aug-2005	30-Aug-2005	-	31-Aug-2005	-	30-Aug-2005	30-Aug-2005

* Results Reported on "As Received" Basis
 N.D. - None Detected

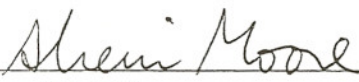
 Cheryl McMillen
 Laboratory Director

Quality Control Summary - All laboratory quality control parameters were found to be within established limits

Kleinfelder Inc. 2006¹

¹ Please see Figure 5 for full citation.

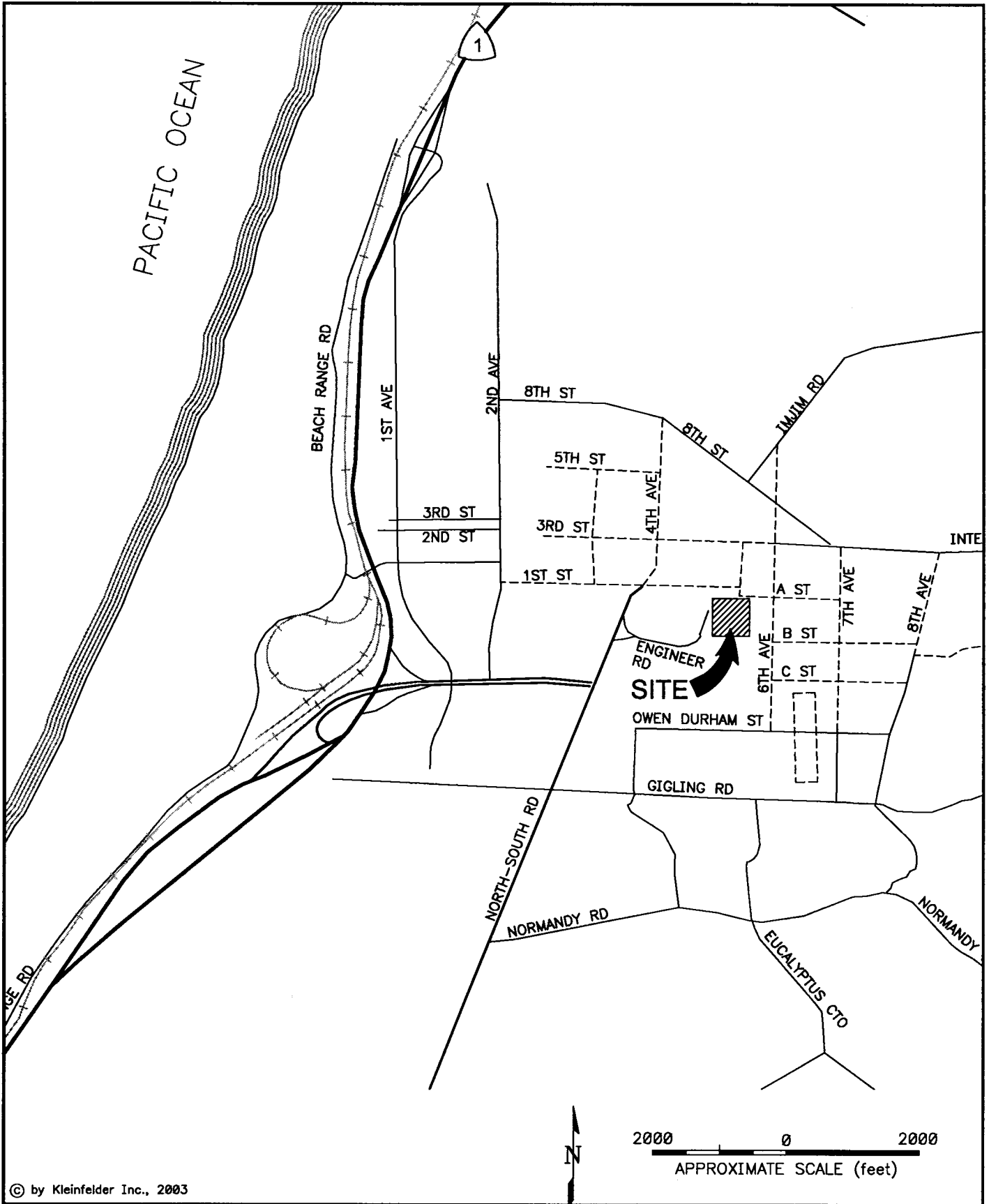

© by Kleinfelder Inc., 2003



365 Victor Street, Suite L
 Salinas, CA 93907
 PH. (831) 755-7900 FAX. (831) 755-7909

SITE VICINITY MAP

PLATE

CSUMB CAMPUS - LIBRARY PROJECT
 FIRST STREET AND FIFTH AVENUE
 SEASIDE, CALIFORNIA

1

DRAFTED BY: L. Sue

CHECKED BY: B. Rinker

DATE: 04-18-03

REVISION DATE:

PROJECT NO. 28624-GEO

ATTACHED XREFS: Xref: TELA-peirto

LEGEND

- LIMITS OF PROJECT SITE
- B-6 SOIL BORING (by Kleinfelder, 2003)

NOTE: Locations are approximate.





200 100 0 200
 APPROXIMATE SCALE (feet)

REFERENCE:
 California State University Monterey Bay, Library Site, not dated.

© by Kleinfelder Inc., 2003

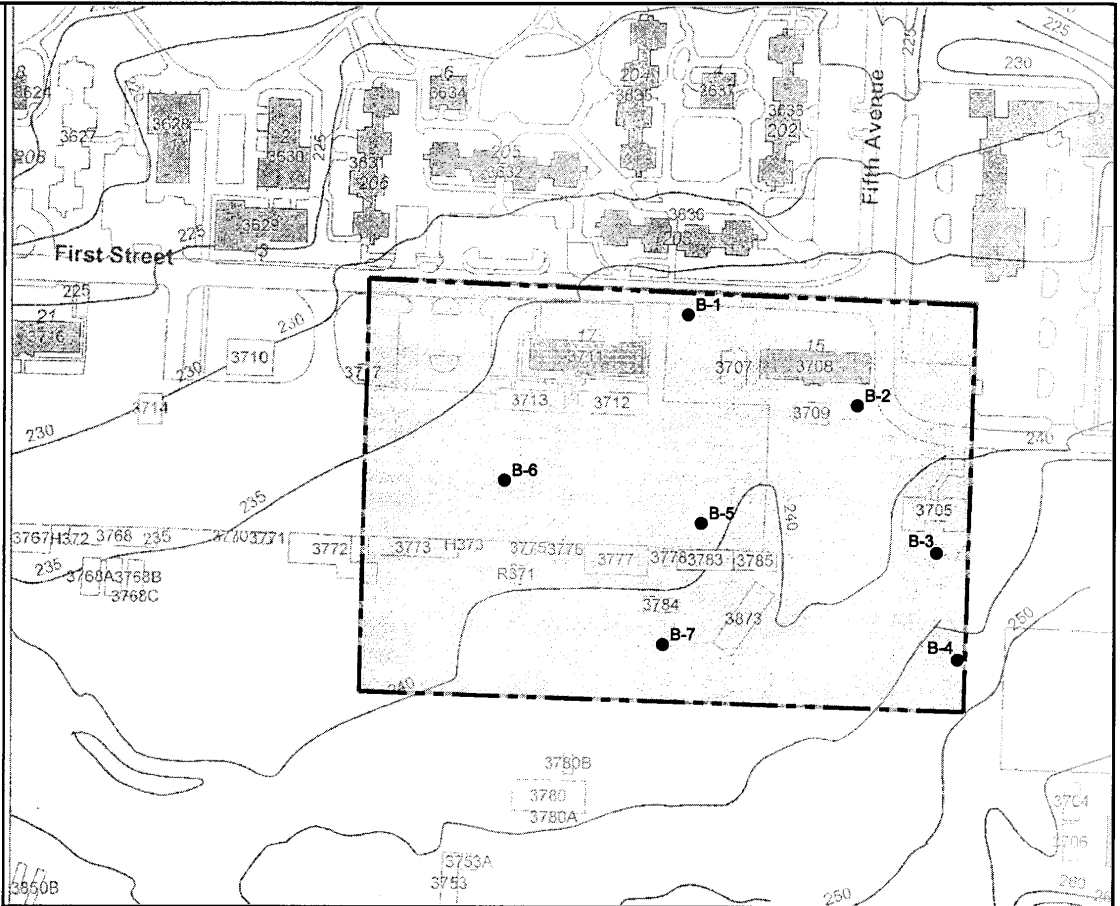
CAD FILE: D:_PROJECTS\28624\GEO\SITEPLAN.dwg
 LAYOUT: Layout1



 KLEINFELDER 365 Victor Street, Suite L Salinas, CA 93907 PH. (831) 755-7900 FAX. (831) 755-7909		SITE PLAN CSUMB CAMPUS - LIBRARY PROJECT FIRST STREET AND FIFTH AVENUE SEASIDE, CALIFORNIA	PLATE 2
DRAFTED BY: L.Sue DATE: 04-18-03	CHECKED BY: B. Hasseler REVISION DATE:	PROJECT NO. 28624-GEO	

ATTACHED XREFS: XRef: TB_A-landscape
 PLOTTED: 18 Apr 2003, 12:43pm

UNIFIED SOIL CLASSIFICATION SYSTEM

MAJOR DIVISIONS		LTR	ID	DESCRIPTION	MAJOR DIVISIONS		LTR	ID	DESCRIPTION
COARSE GRAINED SOILS	GRAVEL AND GRAVELLY	GW		Well-graded gravels or gravel with sand, little or no fines.	FINE GRAINED SOILS	SILTS AND CLAYS	ML		Inorganic silts and very fine sands, rock flour or clayey silts with slight plasticity.
		GP		Poorly-graded gravels or gravel with sand, little or no fines.			CL		Inorganic lean clays of low to medium plasticity, gravelly clays, sandy clays, silty clays.
		GM		Silty gravels, silty gravel with sand mixture.			OL		Organic silts and organic silt-clays of low plasticity.
		GC		Clayey gravels, clayey gravel with sand mixture.			MH		Inorganic elastic silts, micaceous or diatomaceous or silty soils.
	SAND AND SANDY	SW		Well-graded sands or gravelly sands, little or no fines.		SILTS AND CLAYS	CH		Inorganic fat clays (high plasticity).
		SP		Poorly-graded sands or gravelly sands, little or no fines.			OH		Organic clays of medium high to high plasticity.
		SM		Silty sand.			Pt		Peat and other highly organic soils.
		SC		Clayey sand.			HIGHLY ORGANIC SOILS		



Standard Penetration Split Spoon Sampler 2.0 inch, 1.4 inch I.D.

Modified California Sampler 2.5 inch O.D., 2.0 inch I.D.

Bulk Sample

California Sampler 3.0 inch O.D., 2.5 inch I.D.

Shelby Tube 3.0 inch O.D.



Approximate water level first observed in boring. Time recorded in reference to a 24 hour clock.



Approximate water level observed in boring following drilling

PEN Pocket Penetrometer reading, in tsf
 TV:Su Torvane shear strength, in ksf

LL	LIQUID LIMIT	TX	TRIAXIAL SHEAR
PI	PLASTICITY INDEX	CONSOL	CONSOLIDATION
%-#200	SIEVE ANALYSIS (#200 SCREEN)	R-Value	RESISTANCE VALUE
DS	DIRECT SHEAR	SE	SAND EQUIVALENT
C	COHESION (PSF)	EI	EXPANSION INDEX
PHI	FRICTION ANGLE	FS	FREE SWELL (U.S.B.R.)

Notes: Blow counts represent the number of blows a 140-pound hammer falling 30 inches required to drive a sampler through the last 12 inches of an 18 inch penetration, unless otherwise noted.

The lines separating strata on the logs represent approximate boundaries only. The actual transition may be gradual. No warranty is provided as to the continuity of soil strata between borings. Logs represent the soil section observed at the boring location on the date of drilling only.



BORING LOG LEGEND

CSUMB Campus - Library Project
First Street and Fifth Avenue
Seaside, California

PLATE

A-1

PROJECT NO. 28624/GEO

Date Completed: 4/10/03
 Logged By: R. Hasseler
 Total Depth: 51.5 ft

Drilling method: 8" Hollow Stem Auger
 Hammer Wt: 140 lbs., 30" drop
 Notes: _____

Depth, ft	FIELD		LABORATORY				Pen. tsf	DESCRIPTION
	Sample	Blows/ft	Dry Density pcf	Moisture Content %	Compress. Strength tsf	Other Tests		
5	9							SILTY SAND (SM) - dark brown, moist, loose, fine grained sand - red brown
10	13			7				POORLY GRADED SAND (SP) - yellow brown, moist, medium dense, fine grained sand, trace silt
15	20							
20	36			6				- dense
25	36							
30								

L:\200303\PROJECTS\28624\2864.GPJ



PROJECT NO. 28624/GEO

LOG OF BORING NO. B-1

CSUMB Campus - Library Project
 First Street and Fifth Avenue
 Seaside, California

PLATE

A-2

Depth, ft	FIELD		LABORATORY				Pen, tsf	DESCRIPTION
	Sample	Blows/ft	Dry Density pcf	Moisture Content %	Compress. Strength tsf	Other Tests		
		62						(Continued from previous plate)
35		62						- medium grained sand - very dense
40		43						- dense
45		56						- very dense
50		49						- dense
55								End of Boring at 51.5 No free water observed Boring backfilled with drilling spoils
60								

L:\2003\03\PROJECTS\28624\28624.GPJ



PROJECT NO. 28624/GEO

LOG OF BORING NO. B-1
 CSUMB Campus - Library Project
 First Street and Fifth Avenue
 Seaside, California

PLATE

A-2
(cont'd)

Date Completed: 4/9/03
 Logged By: R. Hasseler
 Total Depth: 36.5 ft

Drilling method: 8" Hollow Stem Auger
 Hammer Wt: 140 lbs., 30" drop
 Notes: _____

Depth, ft	FIELD		LABORATORY				Pen, tsf	DESCRIPTION
	Sample	Blows/ft	Dry Density pcf	Moisture Content %	Compress. Strength tsf	Other Tests		
25				7				SILTY SAND (SM) - dark brown, moist, medium dense, fine grained sand - decomposed granite inclusions
5	26		102	5				POORLY GRADED SAND (SP) - yellow brown, moist, medium dense, fine grained sand, trace silt - orange-brown, moist to damp
10	20							
15	24							
20	30							- dense
25	45							
30								



LOG OF BORING NO. B-2
 CSUMB Campus - Library Project
 First Street and Fifth Avenue
 Seaside, California

PLATE
A-3

PROJECT NO. 28624/GEO

L:\2003\03\PROJECTS\28624\28624.GPJ

Depth, ft	FIELD		LABORATORY				Pen, tsf	DESCRIPTION
	Sample	Blows/ft	Dry Density pcf	Moisture Content %	Compress. Strength tsf	Other Tests		
43								(Continued from previous plate)
35	40							- no recovery
40								End of Boring at 36.5 No free water observed Boring backfilled with drilling spoils
45								
50								
55								
60								

L:\00303\PROJECTS\28264\28264.GPJ



KLEINFELDER

PROJECT NO. 28624/GEO

LOG OF BORING NO. B-2
 CSUMB Campus - Library Project
 First Street and Fifth Avenue
 Seaside, California

PLATE

A-3
(cont'd)

Date Completed: 4/9/03

Drilling method: 8" Hollow Stem Auger

Logged By: R. Hasseler

Hammer Wt: 140 lbs., 30" drop

Total Depth: 36.5 ft

Notes: _____

Depth, ft	FIELD		LABORATORY				Pen, tsf	DESCRIPTION
	Sample	Blows/ft	Dry Density pcf	Moisture Content %	Compress. Strength tsf	Other Tests		
43		5					SILTY SAND (SM) - dark brown, moist, dense, fine grained sand - red-brown - loose	
5	9							
10	25	6					POORLY GRADED SAND (SP) - yellow brown, damp, medium dense, fine grained sand, trace silt	
15	20							
20	29							
25	35							
30								

L:\2003\PROJECTS\28624\2864.GPJ



LOG OF BORING NO. B-3

CSUMB Campus - Library Project
 First Street and Fifth Avenue
 Seaside, California

PLATE

A-4

PROJECT NO. 28624/GEO

Depth, ft	FIELD		LABORATORY				Pen, tsf	DESCRIPTION
	Sample	Blows/ft	Dry Density pcf	Moisture Content %	Compress. Strength tsf	Other Tests		
	44							(Continued from previous plate)
35	41							
40								End of Boring at 36.5 No free water observed Boring backfilled with drilling spoils
45								
50								
55								
60								

L:\200303\PROJECTS\28624\28624.GPJ



PROJECT NO. 28624/GEO

LOG OF BORING NO. B-3
 CSUMB Campus - Library Project
 First Street and Fifth Avenue
 Seaside, California

PLATE

A-4
(cont'd)

Date Completed: 4/9/03
 Logged By: R. Hasseler
 Total Depth: 36.5 ft

Drilling method: 8" Hollow Stem Auger
 Hammer Wt: 140 lbs., 30" drop
 Notes: _____

Depth, ft	FIELD		LABORATORY				Pen. tsf	DESCRIPTION
	Sample	Blows/ft	Dry Density pcf	Moisture Content %	Compress. Strength tsf	Other Tests		
5				6				SILTY SAND (SM) - dark brown, moist, loose, fine grained sand
5		27						- red-brown, medium dense
10		25		5				POORLY GRADED SAND (SP) - yellow brown, moist, medium dense, fine grained sand, trace silt
15		24						
20		22						
25		22						- red-brown
30								

L:\2003\03\PROJECTS\28624\28624.GPJ

 KLEINFELDER	LOG OF BORING NO. B-4 CSUMB Campus - Library Project First Street and Fifth Avenue Seaside, California	PLATE A-5
	PROJECT NO. <u>28624/GEO</u>	

Depth, ft	FIELD		LABORATORY				Pen, tsf	DESCRIPTION
	Sample	Blows/ft	Dry Density pcf	Moisture Content %	Compress. Strength tsf	Other Tests		
50								- very dense
35	58							End of Boring at 36.5 No free water observed Boring backfilled with drilling spoils
40								
45								
50								
55								
60								

L:\2003\03\PROJECTS\28624\28624.GPJ



PROJECT NO. 28624/GEO

LOG OF BORING NO. B-4
 CSUMB Campus - Library Project
 First Street and Fifth Avenue
 Seaside, California

PLATE

A-5
(cont'd)

Date Completed: 4/9/03
 Logged By: R. Hasseler
 Total Depth: 36.5 ft

Drilling method: 8" Hollow Stem Auger
 Hammer Wt: 140 lbs., 30" drop
 Notes: _____

Depth, ft	FIELD		LABORATORY				Pen, tsf	DESCRIPTION
	Sample	Blows/ft	Dry Density pcf	Moisture Content %	Compress. Strength tsf	Other Tests		
								Surface Elevation: Estimated feet (MSL)
6								1" AC overlay on 3" AC on 3.5" AB
16			101	5				SILTY SAND (SM) - dark brown, moist, loose, fine grained
								- medium dense
15				4				POORLY GRADED SAND (SP) - yellow brown, moist, medium dense, fine grained sand, trace silt
40								- dense
46								
36								
30								

L:\2003\03PROJECTS\28624\28624.GPJ



LOG OF BORING NO. B-5
 CSUMB Campus - Library Project
 First Street and Fifth Avenue
 Seaside, California

PLATE

A-6

PROJECT NO. 28624/GEO

Depth, ft	FIELD		LABORATORY				Pen, tsf	DESCRIPTION
	Sample	Blows/ft	Dry Density pcf	Moisture Content %	Compress. Strength tsf	Other Tests		
	51							(Continued from previous plate)
35	57							- very dense
40								End of Boring at 36.5 No free water observed Boring backfilled with drilling spoils
45								
50								
55								
60								

L:\2003\03\PROJECTS\28624\28624.GPJ



KLEINFELDER

PROJECT NO. 28624/GEO

LOG OF BORING NO. B-5
 CSUMB Campus - Library Project
 First Street and Fifth Avenue
 Seaside, California

PLATE

A-6
(cont'd)

Date Completed: 4/9/03

Drilling method: 8" Hollow Stem Auger

Logged By: R. Hasseler

Hammer Wt: 140 lbs., 30" drop

Total Depth: 36.5 ft

Notes: _____

Depth, ft	FIELD		LABORATORY				Pen. tsf	DESCRIPTION
	Sample	Blows/ft	Dry Density pcf	Moisture Content %	Compress. Strength tsf	Other Tests		
								Surface Elevation: Estimated feet (MSL)
								1" AC on 3.5" AC over 3" AB
5	25							POORLY GRADED SAND with SILT (SP-SM) - orange-brown, moist, medium dense, fine grained sand
	26		103	6				
10	9			5				SILTY SAND (SM) - dark brown, moist - loose fine grained sand
15	48							POORLY GRADED SAND (SP) - yellow brown, moist, medium dense, fine grained sand, trace silt
20	45							
25	38							
30								

L:\2003\03PROJECT\SV28264\28264.GPJ



LOG OF BORING NO. B-6

CSUMB Campus - Library Project
 First Street and Fifth Avenue
 Seaside, California

PLATE

A-7

PROJECT NO. 28624/GEO

Depth, ft	FIELD		LABORATORY				Pen, tsf	DESCRIPTION
	Sample	Blows/ft	Dry Density pcf	Moisture Content %	Compress. Strength tsf	Other Tests		
		49						(Continued from previous plate)
35		55						
40								- very dense End of Boring at 36.5 No free water observed Boring backfilled with drilling spoils
45								
50								
55								
60								

L:\2003\03\PROJECT\28624\28624.GPJ



KLEINFELDER

PROJECT NO. 28624/GEO

LOG OF BORING NO. B-6
 CSUMB Campus - Library Project
 First Street and Fifth Avenue
 Seaside, California

PLATE

A-7
(cont'd)

Date Completed: 4/10/03

Drilling method: 8" Hollow Stem Auger

Logged By: R. Hasseler

Hammer Wt: 140 lbs., 30" drop

Total Depth: 51.5 ft

Notes:

Depth, ft	FIELD		LABORATORY				Pen, tsf	DESCRIPTION
	Sample	Blows/ft	Dry Density pcf	Moisture Content %	Compress. Strength tsf	Other Tests		
5	26							SILTY SAND (SM) - dark brown, moist, medium dense, fine grained sand
10	38	105	8			-#200 = 10%		POORLY GRADED SAND with SILT (SP-SM) - yellow-brown, moist, dense, fine grained sand
15	12		9					SILTY SAND (SM) - dark brown, moist, medium dense, fine grained sand
20	9							- loose
25	15		7					POORLY GRADED SAND (SP) - orange brown, moist, medium dense, fine grained sand, trace silt
30	32							- dense

L:\2003\03\PROJECTS\2864\28284.GPJ



LOG OF BORING NO. B-7

CSUMB Campus - Library Project
 First Street and Fifth Avenue
 Seaside, California

PLATE

A-8

PROJECT NO. 28624/GEO

Depth, ft	FIELD		LABORATORY				Pen, tsf	DESCRIPTION
	Sample	Blows/ft	Dry Density pcf	Moisture Content %	Compress. Strength tsf	Other Tests		
				5				(Continued from previous plate)
35	41					-#200 = 4%		- grading to medium grained sand
40	52							- very dense
45	33							- dense
50	50							
55								End of Boring at 51.5 No free water observed Boring backfilled with drilling spoils
60								

L:\2003\03\PROJECTS\28624\28264.GPJ



PROJECT NO. 28624/GEO

LOG OF BORING NO. B-7
 CSUMB Campus - Library Project
 First Street and Fifth Avenue
 Seaside, California

PLATE

A-8
(cont'd)

S I E V E A N A L Y S I S

H Y D R O M E T E R

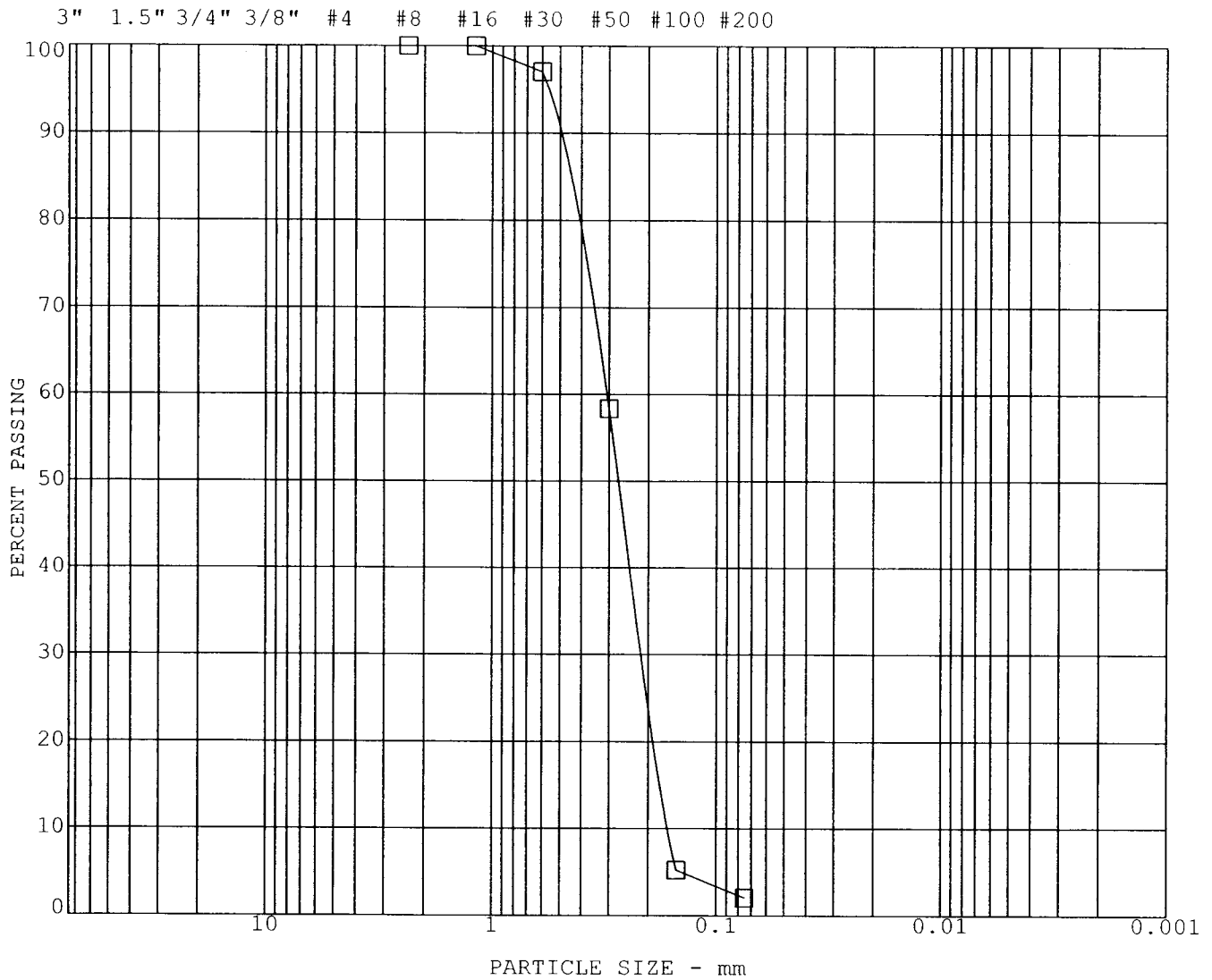

GRAVEL		SAND			FINES
coarse	fine	coarse	medium	fine	

<u>SYMBOL</u>	<u>BORING</u>	<u>DEPTH (ft)</u>	<u>CLASSIFICATION</u>
□	B-1	15.0	Yellow Brown Poorly Graded Sand, trace silt



GRAIN SIZE DISTRIBUTION
CSUMB Library

PLATE

B-1

PROJECT NO. 28324-GEO

L:\2003\03\PROJECTS\28624\28624.GPJ

SIEVE ANALYSIS

HYDROMETER

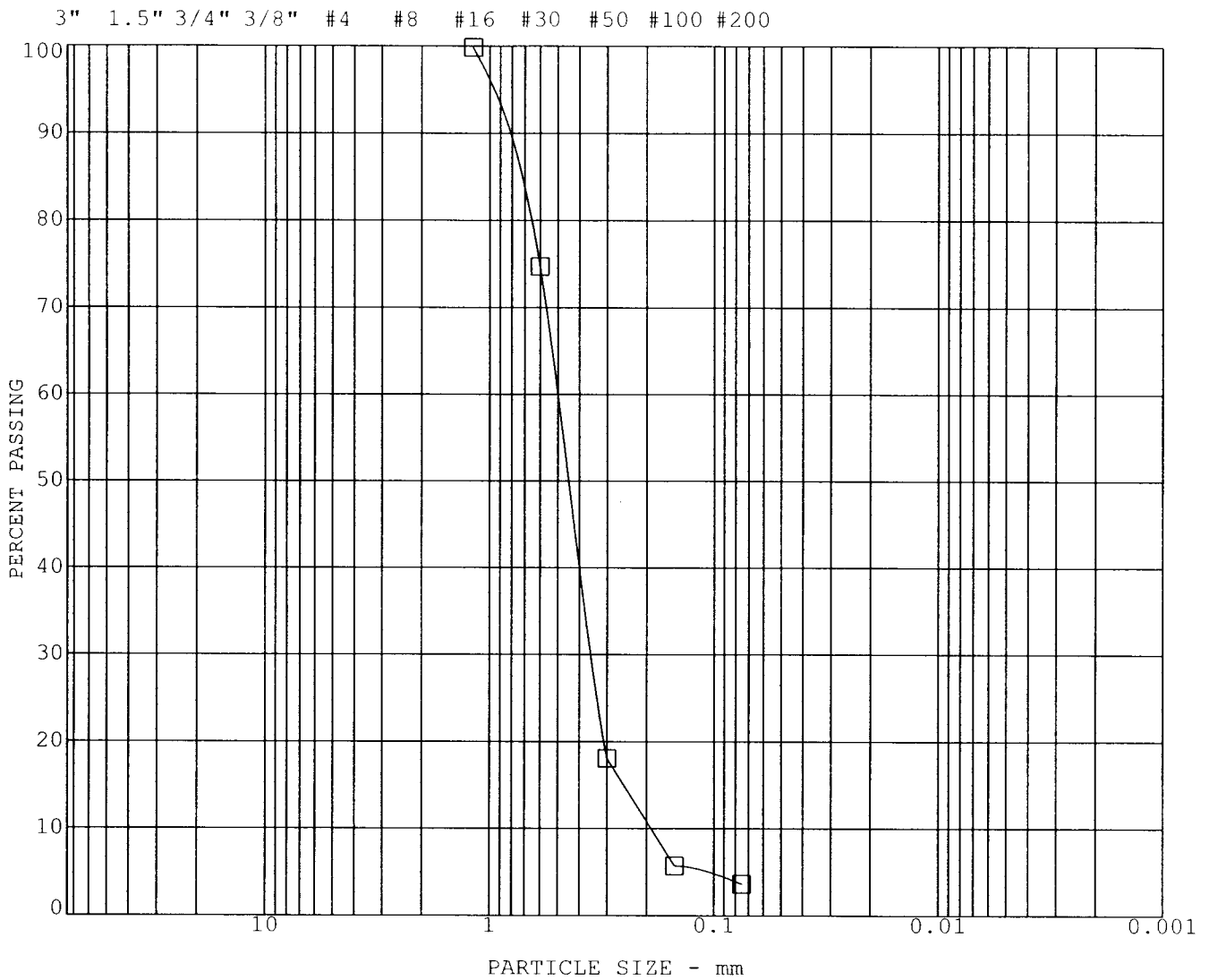

GRAVEL		SAND			FINES
coarse	fine	coarse	medium	fine	

SYMBOL	BORING	DEPTH (ft)	CLASSIFICATION
□	B-7	35.0	Yellow Brown Poorly Graded Sand, trace silt

L:\2003\03\PROJECTS\28624\28624.GPJ



GRAIN SIZE DISTRIBUTION
CSUMB Library

PLATE

B-2

PROJECT NO. 28624-GEO

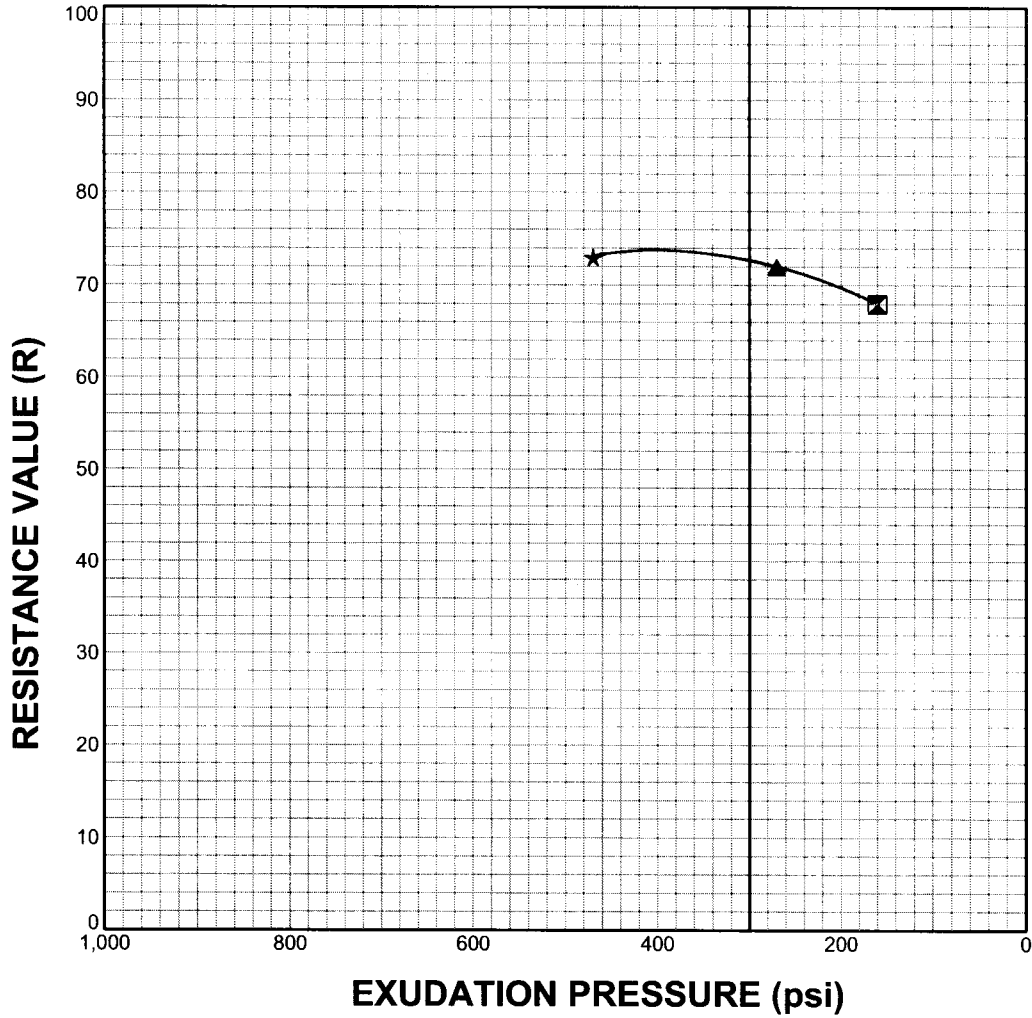

SPECIMEN NO.	☒	▲	★
MOISTURE CONTENT (%)	18.2	17.3	16.3
DRY DENSITY (PCF)	114.0	118.3	116.3
EXUDATION PRESSURE (PSI)	160	270	470
EXPANSION PRESSURE (PSF)	0	17	26
RESISTANCE VALUE (R)	68	72	73

Date Received: 4/18/03

SAMPLE SOURCE	CLASSIFICATION	SAND EQUIVALENT	EXPANSION PRESSURE	R-VALUE
(PL6180) Bulk #1, Surface	Dark Brown Silty Sand	---	19 psf	73

ASTM D 2844, Cal Test 301



KLEINFELDER

RESISTANCE VALUE TEST DATA
CSUMB Library

PLATE

B-3

PROJECT NO. 28624-GEO

7 May, 2003

Job No.0304184
Cust. No.11454

3942-A Valley Avenue
Pleasanton, CA 94566-4715
Tel: 925.462.2771
Fax: 925.462.2775

Mr. Robert G. Hasseler, P.E.
Kleinfelder
365 Victor Street, Suite L
Salinas, CA 93907

Subject: Project No.: 28624-GEO
Project Name: CSUMB Library
Corrosivity Analysis – ASTM Test Methods

Dear Mr. Hasseler:

Pursuant to your request, CERCO Analytical has analyzed the soil sample submitted on April 18, 2003. Based on the analytical results, a brief corrosivity evaluation is enclosed for your consideration.

Based upon the resistivity measurements, this sample is classified as "corrosive". All buried iron, steel, cast iron, ductile iron, galvanized steel and dielectric coated steel or iron should be properly protected against corrosion depending upon the critical nature of the structure. All buried metallic pressure piping such as ductile iron firewater pipelines should be protected against corrosion.

The chloride ion concentration reflects none detected with a detection limit of 15 mg/kg.

The sulfate ion concentration is 27 mg/kg and is determined to be insufficient to damage reinforced concrete structures and cement mortar-coated steel at this location.

The pH of the soil is 5.7 which does present corrosion problems for buried iron, steel, mortar-coated steel and reinforced concrete structures. Any soils with a pH of <6.0 is considered to be corrosive to buried iron, steel, mortar-coated steel and reinforced concrete structures. Therefore, corrosion prevention measures need to be considered for structures to be placed in this acidic soil.

The redox potential is 410-mV, which is indicative of aerobic soil conditions.

This corrosivity evaluation is based on general corrosion engineering standards and is non-specific in nature. For specific long-term corrosion control design recommendations or consultation, please call JDH Corrosion Consultants, Inc. at (925) 927-6630.

We appreciate the opportunity of working with you on this project. If you have any questions, or if you required further information, please do not hesitate to contact us.

Very truly yours,

CERCO ANALYTICAL, INC.

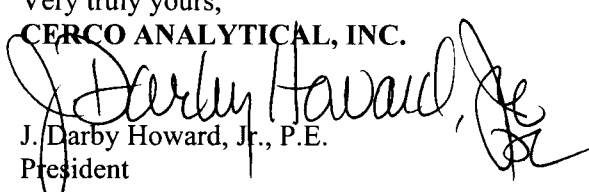
J. Darby Howard, Jr., P.E.
President

JDH/jdl
Enclosure

Pacific Crest Engineering 2004¹

¹ Please see Figure 5 for full citation.



Base Map from Thomas Bros. Maps

Pacific Crest Engineering Inc.
 444 Airport Blvd., Suite 106
 Watsonville, CA 95076

Regional Site Plan
 FORA Road Improvements
 Seaside, California

Figure No. 1
 Project No. 03102
 Date: 02/26/04

Pacific Crest Engineering Inc. 2/17/2004 5:31 PM 11x17.dwg

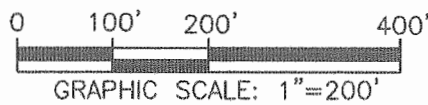
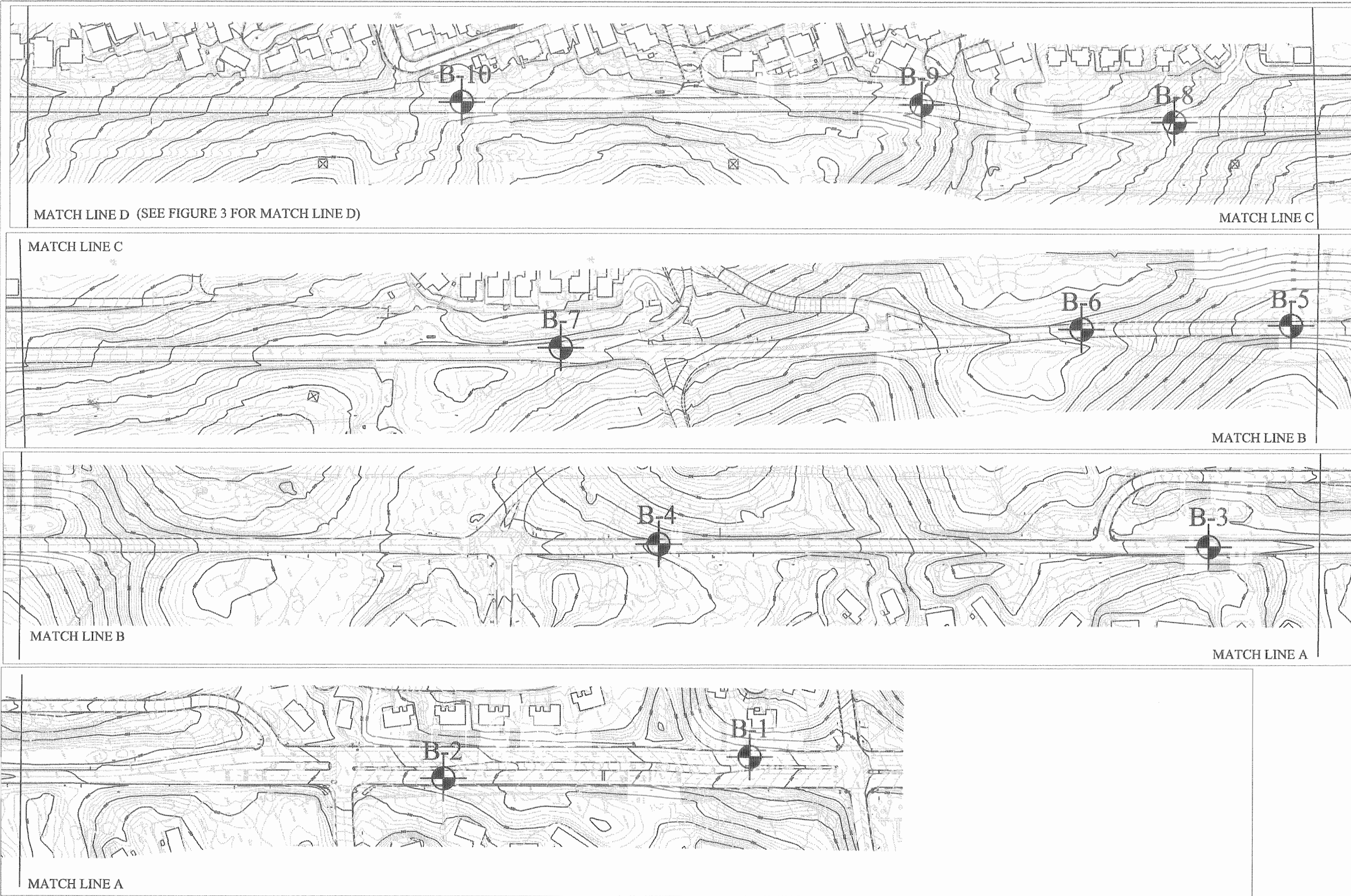

 = APPROXIMATE LOCATION OF TEST BORING
 BASE MAP FROM BESTOR ENGINEERS, INC.

GENERAL JIM MOORE BLVD.



2/26/04 03102
 REV. 0 DME

FIGURE 2

FORA ROAD IMPROVEMENTS
 SEASIDE, CALIFORNIA

SITE PLAN SHOWING TEST BORINGS

PACIFIC CREST ENGINEERING INC.

444 AIRPORT BLVD, SUITE 106 TEL (831) 722-9446
 WATSONVILLE, CA 95076 FAX (831) 722-9158

GRAPHIC SCALE: 1"=200'
0 100' 200' 400'

= APPROXIMATE LOCATION OF TEST BORING
BASE MAP FROM BESTOR ENGINEERS, INC.

GENERAL JIM MOORE BLVD.

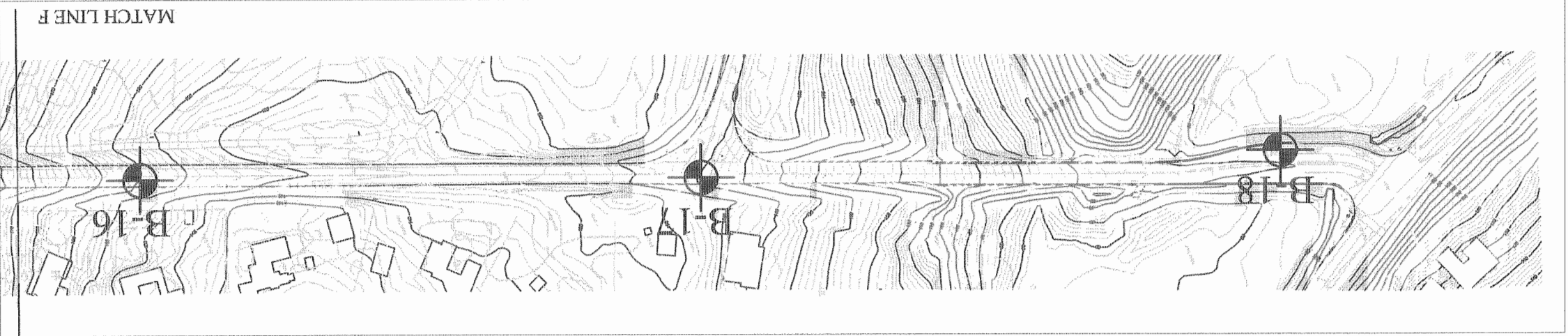
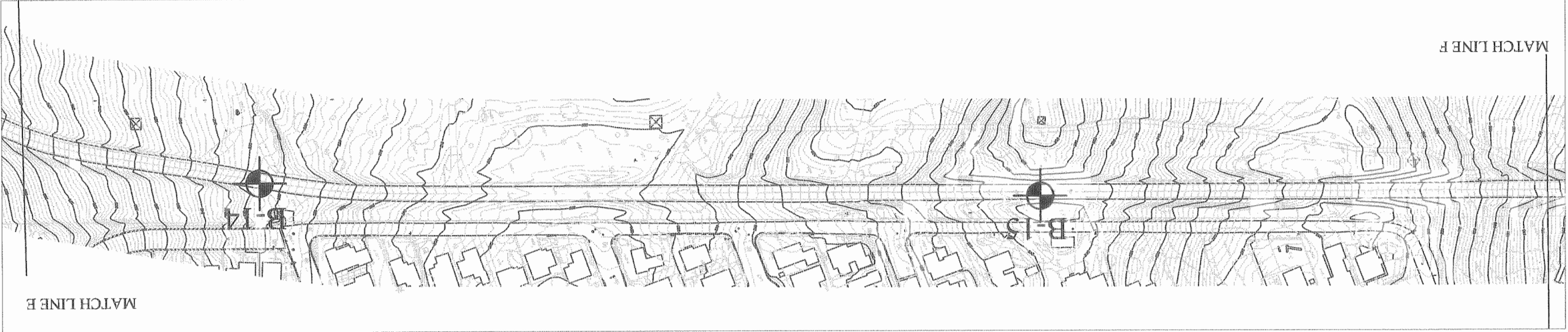
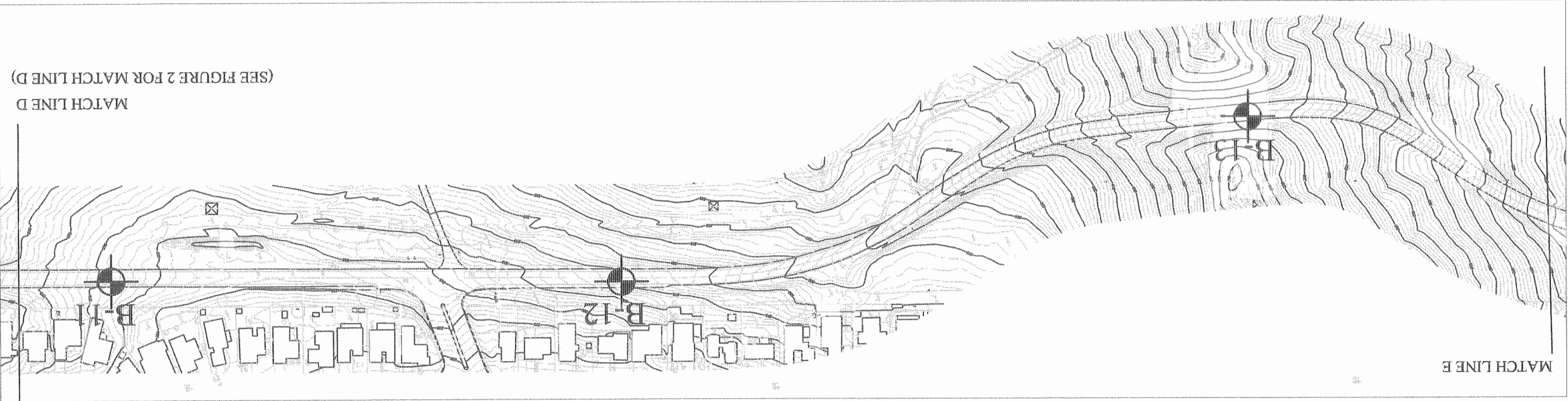

PACIFIC CREST ENGINEERING INC.

444 AIRPORT BLVD, SUITE 106
WATSONVILLE, CA 95076

TEL (831) 722-9446
FAX (831) 722-9158





FORA ROAD IMPROVEMENTS
SEASIDE, CALIFORNIA

SITE PLAN SHOWING TEST BORINGS

2/26/04 03102
REV. 0 DME

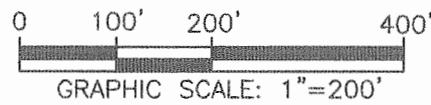
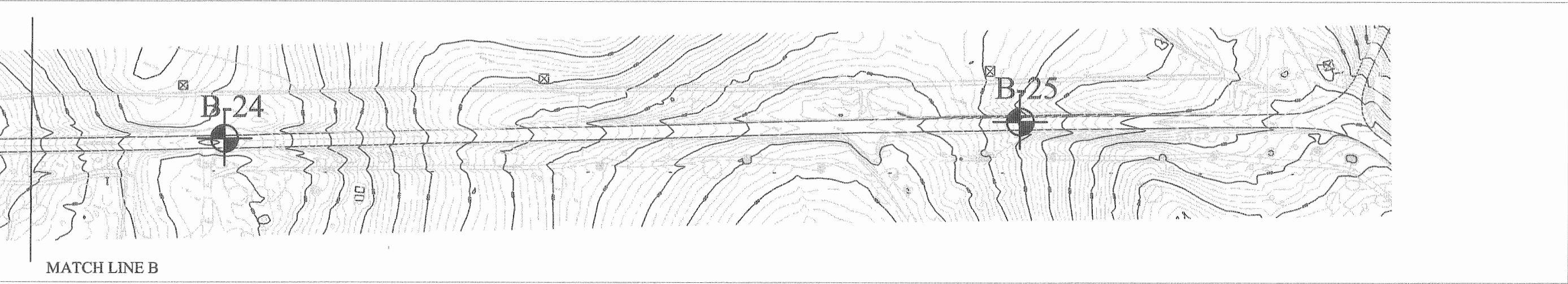
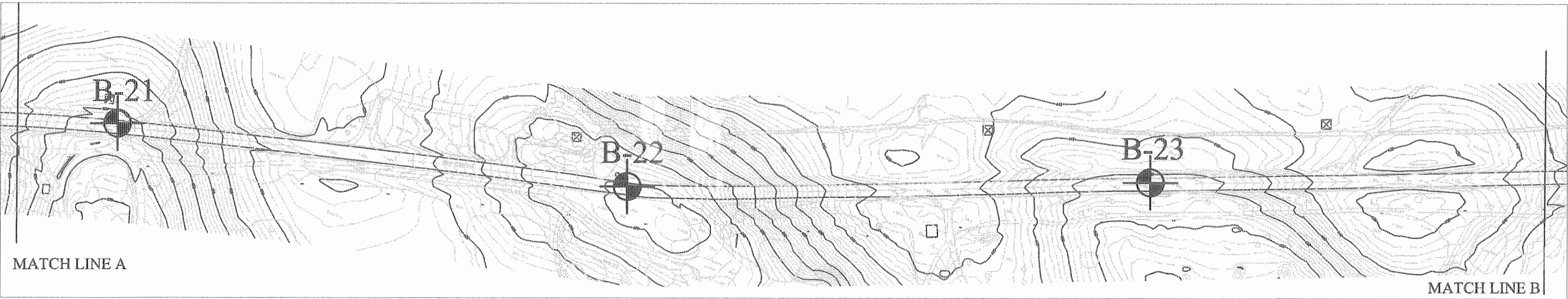
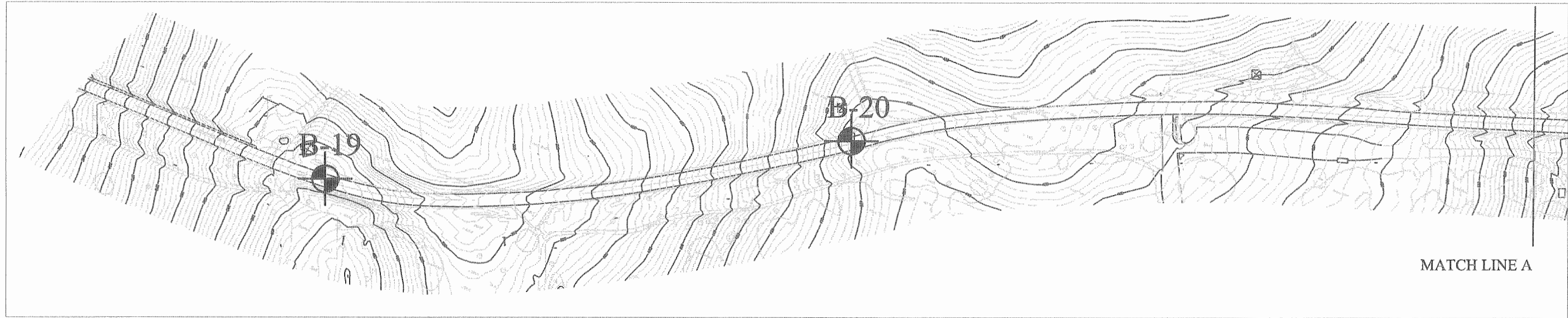
FIGURE 3



 = APPROXIMATE LOCATION OF TEST BORING
 BASE MAP FROM BESTOR ENGINEERS, INC.

EUCALYPTUS ROAD



2/26/04 03102
REV. 0 DME

FIGURE 4

FORA ROAD IMPROVEMNETS
SEASIDE, CALIFORNIA

SITE PLAN SHOWING TEST BORINGS

PACIFIC CREST ENGINEERING INC. 

444 AIRPORT BLVD SUITE 106 TEL (831) 722-9446
 WATSONVILLE, CA 95076 FAX (831) 722-9158

UNIFIED SOIL CLASSIFICATION SYSTEM - ASTM D2488 (Modified)

PRIMARY DIVISIONS		GROUP SYMBOL	SECONDARY DIVISIONS
COARSE GRAINED SOILS MORE THAN HALF OF MATERIAL IS LARGER THAN #200 SIEVE SIZE	GRAVELS MORE THAN HALF OF COARSE FRACTION IS LARGER THAN #4 SIEVE	CLEAN GRAVELS (LESS THAN 5% FINES)	GW Well graded gravels, gravel-sand mixtures, little or no fines
		GRAVELS (MORE THAN 12% FINES)	GP Poorly graded gravels or gravels-sand mixtures, little or no fines
			GM Silty gravels, gravel-sand-silt mixtures, non-plastic fines
			GC Clayey gravels, gravel-sand-clay mixtures, plastic fines
	SANDS MORE THAN HALF OF COARSE FRACTION IS SMALLER THAN #4 SIEVE	CLEAN SANDS (LESS THAN 5% FINES)	SW Well graded sands, gravelly sands, little or no fines
			SP Poorly graded sands or gravelly sands, little or no fines
		SANDS (MORE THAN 12% FINES)	SM Silty sands, sand-silt mixtures, non-plastic fines
			SC Clayey sands, sand-clay mixtures, plastic fines
FINE GRAINED SOILS MORE THAN HALF OF MATERIAL IS SMALLER THAN #200 SIEVE SIZE	SILTS AND CLAYS LIQUID LIMIT IS LESS THAN 35%		ML Inorganic silts and very fine clayey sand silty sands, with slight plasticity
			CL Inorganic clays of low to medium plasticity, gravelly, sand, silty or lean clays
			OL Organic silts and organic silty clays of low plasticity
	SILTS AND CLAYS LIQUID LIMIT IS BETWEEN 35% AND 50%		MI Inorganic silts, clayey silts and silty fine sands of intermediate plasticity
			CI Inorganic clays, gravelly/sandy clays and silty clays of intermediate plasticity
			OI Organic clays and silty clays of intermediate plasticity
			MH Inorganic silts, micaceous or diatomaceous fine sandy or silty soils, elastic silts
	SILTS AND CLAYS LIQUID LIMIT IS GREATER THAN 50%		CH Organic clays of high plasticity, fat clays
			OH Organic clays of medium to high plasticity, organic silts
			HIGHLY ORGANIC SOILS
		PT Peat and other highly organic soils	

BORING LOG EXPLANATION

LOGGED BY _____ DATE DRILLED _____ BORING DIAMETER _____ BORING NO. _____

Depth, ft.	Sample No. and Type	Symbol	SOIL DESCRIPTION	Unified Soil Classification	SPT "N" Value	Plasticity Index	Dry Density, p.c.f.	Moisture % of Dry Wt.	MISC. LAB RESULTS
1			← Ground water elevation						
2	1-1		← Soil Sample Number ← Soil Sampler Size/Type L = 3" Outside Diameter M = 2.5" Outside Diameter T = 2" Outside Diameter ST = Shelby Tube BAG = Bag Sample						
3									
4									
5									

RELATIVE DENSITY

SANDS AND GRAVELS	BLOWS/FOOT
VERY LOOSE	0-4
LOOSE	4-10
MEDIUM DENSE	10-30
DENSE	30-50
VERY DENSE	OVER 50

CONSISTENCY

SILTS AND CLAYS	BLOWS/FOOT
VERY SOFT	0-2
SOFT	2-4
FIRM	4-8
STIFF	8-16
VERY STIFF	16-32
HARD	OVER 32

Pacific Crest Engineering Inc.
444 Airport Blvd., Suite 106
Watsonville, CA 95076

Boring Log Explanation
FORA Road Improvements
Seaside, California

Figure No. 5
Project No. 03102
Date: 02/26/04

LOGGED BY		DE		DATE DRILLED		1/23/04		BORING DIAMETER		6" SS		BORING NO.		1		
Depth (feet)	Sample No. and Type	Symbol	Soil Description					Unified Soil Classification	SPT "N" Value	Plasticity Index	Dry Density (pcf)	Moisture % of Dry Wt.	Misc. Lab Results			
1			5" Baserock													
2	1-1 L		Yellowish brown Silty SAND, fine grained sand, moist, medium dense					SP-SM	30		107.9	6.4	12% Passing #200 Sieve			
3																
4																
5	1-2 L		Yellowish brown SAND, fine grained sand, moist, medium dense						28		113.5	4.4				
6																
7																
8																
9																
10	1-3 T		Dark yellowish brown SAND, fine grained sand, damp medium dense						13			2.9				
11																
12			Boring Terminated at 11 1/2'													
13																
14																
15																
16																
17																
18																
19																
20																
21																
22																
23																
24																

Pacific Crest Engineering Inc.
 444 Airport Blvd., Suite 106
 Watsonville, CA 95076

Log of Test Borings
 FORA Road Improvements
 Seaside, California

Figure No. 6
 Project No. 03102
 Date: 02/26/04

LOGGED BY DE DATE DRILLED 1/23/04 BORING DIAMETER 6" SS BORING NO. 2

Depth (feet)	Sample No. and Type	Symbol	Soil Description	Unified Soil Classification	SPT "N" Value	Plasticity Index	Dry Density (pcf)	Moisture % of Dry Wt.	Misc. Lab Results
			3" AC						
			5" Baserock						
1	2-1		Dark yellowish brown SAND, fine grained sand, damp, medium dense	SP	17			4.8	
2	T								
3									
4			Yellowish brown SAND, fine grained sand, damp, medium dense		16			5.2	
5	2-2								
6	T								
7			Yellowish brown SAND, medium grained sand, moist, medium dense		13			4.9	
8									
9									
10	2-3								
11	T								
12			Boring Terminated at 11 1/2'						
13									
14									
15									
16									
17									
18									
19									
20									
21									
22									
23									
24									

LOGGED BY DE DATE DRILLED 1/23/04 BORING DIAMETER 6" SS BORING NO. 3

Depth (feet)	Sample No. and Type	Symbol	Soil Description	Unified Soil Classification	SPT "N" Value	Plasticity Index	Dry Density (pcf)	Moisture % of Dry Wt.	Misc. Lab Results
0			5" AC						
0			7" Baserock						
1	3-1 T		Yellowish brown SAND, fine grained sand	SP	28			10.9	
2									
3									
4	3-2 L		Yellowish brown SAND, fine grained sand, moist, medium dense		19		104.5	9.5	5% Passing #200 Sieve
5									
6									
7	3-3 L		Yellowish brown SAND, fine grained sand, moist, medium dense		15		99.1	3.9	
8									
9									
10	Boring Terminated at 11 1/2'								
11									
12									
13									
14									
15									
16									
17									
18									
19									
20									
21									
22									
23									
24									

Pacific Crest Engineering Inc.
444 Airport Blvd., Suite 106
Watsonville, CA 95076

Log of Test Borings
FORA Road Improvements
Seaside, California

Figure No. 8
Project No. 03102
Date: 02/26/04

LOGGED BY DE DATE DRILLED 1/23/04 BORING DIAMETER 6" SS BORING NO. 4

Depth (feet)	Sample No. and Type	Symbol	Soil Description	Unified Soil Classification	SPT "N" Value	Plasticity Index	Dry Density (pcf)	Moisture % of Dry Wt.	Misc. Lab Results
			4" AC						
			5" Baserock						
1	4-1		No Sample Recovered	SM	50/4"				
2	L		Dark yellowish brown Silty SAND, very fine grained sand, damp, very dense						
3									
4				SP					
5	4-2		Yellowish brown SAND, fine grained sand, damp, dense		32		112.1	6.2	
6	L								
7									
8									
9									
10	4-3		Yellowish brown SAND, fine grained sand, moist medium dense		16			2.6	
11	T								
12			Boring Terminated at 11 1/2'						
13									
14									
15									
16									
17									
18									
19									
20									
21									
22									
23									
24									

LOGGED BY DE DATE DRILLED 1/23/04 BORING DIAMETER 6" SS BORING NO. 5									
Depth (feet)	Sample No. and Type	Symbol	Soil Description (Proposed Roadway Cut of 11 feet)	Unified Soil Classification	SPT "N" Value	Plasticity Index	Dry Density (pcf)	Moisture % of Dry Wt.	Misc. Lab Results
			6 1/2" AC						
1	5-1 L		Light yellowish brown SAND, fine grained sand, moist, medium dense	SP					
2					29		104.5	2.9	4% Passing #200 Sieve
3									
4									
5	5-2 L		Yellowish brown SAND, fine grained sand, moist, medium dense						
6					13		106.1	2.6	
7									
8									
9									
10	5-3 L		Material consistent						
11					16		99.1	2.3	
12									
13									
14									
15	5-4 T		Yellowish brown SAND, medium grained sand, moist, medium dense						
16					25			2.8	
17			Boring Terminated at 16 1/2'						
18									
19									
20									
21									
22									
23									
24									

Pacific Crest Engineering Inc.
444 Airport Blvd., Suite 106
Watsonville, CA 95076

Log of Test Borings
FORA Road Improvements
Seaside, California

Figure No. 10
Project No. 03102
Date: 02/26/04

LOGGED BY		DE		DATE DRILLED		1/23/04		BORING DIAMETER		6" SS		BORING NO.		6		
Depth (feet)	Sample No. and Type	Symbol	Soil Description					Unified Soil Classification	SPT "N" Value	Plasticity Index	Dry Density (pcf)	Moisture % of Dry Wt.	Misc. Lab Results			
1	6-1 L		7" AC					SP	34		105.1	2.8	6% Passing #200 Sieve			
2			Yellowish brown SAND with silt, fine grained sand, moist, dense													
3																
4	6-2 L		Brown Silty SAND, fine grained sand, moist, loose					SP-SM	9		109.5	4.0				
5																
6																
7																
8	6-3 T		Light yellowish brown SAND, fine grained sand, moist, medium dense						20			2.4				
9																
10																
11	Boring Terminated at 11 1/2'															
12																
13																
14																
15																
16																
17																
18																
19																
20																
21																
22																
23																
24																

Pacific Crest Engineering Inc.
444 Airport Blvd., Suite 106
Watsonville, CA 95076

Log of Test Borings
FORA Road Improvements
Seaside, California

Figure No. 11
Project No. 03102
Date: 02/26/04

LOGGED BY		DE		DATE DRILLED		1/23/04		BORING DIAMETER		6" SS		BORING NO.		7		
Depth (feet)	Sample No. and Type	Symbol	Soil Description					Unified Soil Classification	SPT "N" Value	Plasticity Index	Dry Density (pcf)	Moisture % of Dry Wt.	Misc. Lab Results			
1			4" AC													
1			8" Baserock													
2	7-1 L		Brown SAND with silt, fine grained sand, damp, loose					SP-SM								
3									6		106.5	5.7	10% Passing #200 Sieve			
4																
5	7-2 L		Light yellowish brown SAND, fine grained sand, moist, loose													
6									8		98.3	3.6				
7																
8																
9																
10	7-3 T		Light yellowish brown SAND, fine grained sand, moist, medium dense													
11									16			3.0				
12			Boring Terminated at 11 1/2'													
13																
14																
15																
16																
17																
18																
19																
20																
21																
22																
23																
24																

Pacific Crest Engineering Inc.
444 Airport Blvd., Suite 106
Watsonville, CA 95076

Log of Test Borings
FORA Road Improvements
Seaside, California

Figure No. 12
Project No. 03102
Date: 02/26/04

LOGGED BY DE DATE DRILLED 1/23/04 BORING DIAMETER 6" SS BORING NO. 8									
Depth (feet)	Sample No. and Type	Symbol	Soil Description	Unified Soil Classification	SPT "N" Value	Plasticity Index	Dry Density (pcf)	Moisture % of Dry Wt.	Misc. Lab Results
1	8-1 L		4" AC, 2" Baserock	SP					
2			Yellowish brown SAND, fine grained sand, moist, dense		34		103.6	3.0	
3									
4									
5	8-2 L		Light yellowish brown SAND, fine grained sand, moist, loose		10		98.3	2.1	3% Passing #200 Sieve
6									
7									
8									
9									
10	8-3 T		Light yellowish brown SAND, fine grained sand, moist, medium dense		21			6.1	
11									
12			Boring Terminated at 11 1/2'						
13									
14									
15									
16									
17									
18									
19									
20									
21									
22									
23									
24									

Pacific Crest Engineering Inc.
444 Airport Blvd., Suite 106
Watsonville, CA 95076

Log of Test Borings
FORA Road Improvements
Seaside, California

Figure No. 13
Project No. 03102
Date: 02/26/04

LOGGED BY		DE		DATE DRILLED		1/23/04		BORING DIAMETER		6" SS		BORING NO.		9	
Depth (feet)	Sample No. and Type	Symbol	Soil Description				Unified Soil Classification	SPT "N" Value	Plasticity Index	Dry Density (pcf)	Moisture % of Dry Wt.	Misc. Lab Results			
1			2" AC, 4" Baserock												
2	9-1 L		Light yellowish brown SAND, fine grained sand, moist, medium dense				SP	13		105.1	1.9				
3															
4															
5	9-2 L		Light yellowish brown SAND, fine grained sand, moist, loose					8		104.5	1.9				
6															
7															
8															
9															
10	9-3 T		Light yellowish brown SAND, very fine grained sand, moist, medium dense					17			2.4				
11															
12															
13															
14															
15	9-4 T		Material consistent					24			2.0				
16															
17			Boring Terminated at 16 1/2'												
18															
19															
20															
21															
22															
23															
24															

Pacific Crest Engineering Inc.
444 Airport Blvd., Suite 106
Watsonville, CA 95076

Log of Test Borings
FORA Road Improvements
Seaside, California

Figure No. 14
Project No. 03102
Date: 02/26/04

LOGGED BY DE DATE DRILLED 1/23/04 BORING DIAMETER 6" SS BORING NO. 10

Depth (feet)	Sample No. and Type	Symbol	Soil Description	Unified Soil Classification	SPT "N" Value	Plasticity Index	Dry Density (pcf)	Moisture % of Dry Wt.	Misc. Lab Results
			2" AC, 2" Baserock						
1	10-1	L	Brown SAND, fine grained sand, moist, medium dense	SP					
2					13		107.9	5.3	4% Passing #200 Sieve
3									
4									
5	10-2	L	Brown SAND with silt, fine grained sand, moist, medium dense						
6					16		106.3	4.4	
7									
8									
9									
10	10-3	T	Light yellowish brown SAND, fine grained sand, moist, medium dense						
11					14			2.0	
12									
13									
14									
15	10-4	T	Material consistent						
16					15			2.0	
17			Boring Terminated at 16 1/2'						
18									
19									
20									
21									
22									
23									
24									

LOGGED BY		DE		DATE DRILLED		1/23/04		BORING DIAMETER		6" SS		BORING NO.		11	
Depth (feet)	Sample No. and Type	Symbol	Soil Description	Unified Soil Classification	SPT "N" Value	Plasticity Index	Dry Density (pcf)	Moisture % of Dry Wt.	Misc. Lab Results						
1	11-1 L		4" AC, 3" Baserock												
2			Brown SAND with silt, fine grained sand, moist, medium dense	SP	13		103.4	3.9							
3															
4															
5	11-2 L		Brown SAND with silt, fine grained sand, moist, loose		5		94.0	3.6							
6															
7															
8															
9															
10	11-3 L		Brown SAND with silt, fine grained sand, moist, loose		10		103.7	2.7							
11															
12			Boring Terminated 11 1/2'												
13															
14															
15															
16															
17															
18															
19															
20															
21															
22															
23															
24															

Pacific Crest Engineering Inc.
444 Airport Blvd., Suite 106
Watsonville, CA 95076

Log of Test Borings
FORA Road Improvements
Seaside, California

Figure No. 16
Project No. 03102
Date: 02/26/04

LOGGED BY		DE		DATE DRILLED		1/23/04		BORING DIAMETER		6" SS		BORING NO.		12	
Depth (feet)	Sample No. and Type	Symbol	Soil Description					Unified Soil Classification	SPT "N" Value	Plasticity Index	Dry Density (pcf)	Moisture % of Dry Wt.	Misc. Lab Results		
1	12-1 L		3" AC, 4" Baserock					SP	12		103.9	4.0			
2			Yellowish brown SAND, fine grained sand, moist, medium dense												
3	12-2 L		Yellowish brown SAND, fine grained sand, moist, loose						6		101.2	4.5	4% Passing #200 Sieve		
4															
5															
6															
7	12-3 T		Light yellowish brown SAND, fine grained sand, moist, medium dense						17			2.1			
8															
9															
10	Boring Terminated at 11 1/2'														
11															
12															
13															
14															
15															
16															
17															
18															
19															
20															
21															
22															
23															
24															

Pacific Crest Engineering Inc.
444 Airport Blvd., Suite 106
Watsonville, CA 95076

Log of Test Borings
FORA Road Improvements
Seaside, California

Figure No. 17
Project No. 03102
Date: 02/26/04

LOGGED BY <u>DE</u> DATE DRILLED <u>1/23/04</u> BORING DIAMETER <u>6" SS</u> BORING NO. <u>13</u>									
Depth (feet)	Sample No. and Type	Symbol	Soil Description	Unified Soil Classification	SPT "N" Value	Plasticity Index	Dry Density (pcf)	Moisture % of Dry Wt.	Misc. Lab Results
			(Proposed Roadway Cut of 20')						
			2" AC, 1" Base rock						
1				SP					
2									
3									
4									
5	13-1 T		Light yellowish brown SAND, fine grained sand, moist, loose		10			2.8	
6									
7									
8									
9									
10	13-2 L		Light yellowish brown SAND, fine grained sand, moist, loose		10		105.0	1.9	
11									
12									
13									
14									
15	13-3 T		Light yellowish brown SAND, fine grained sand, moist, medium dense		25			4.2	
16									
17									
18									
19									
20	13-4 T		Light yellowish brown SAND, fine grained sand, moist, medium dense		26			4.1	4% Passing #200 Sieve
21									
22									
23									
24									

Pacific Crest Engineering Inc.
444 Airport Blvd., Suite 106
Watsonville, CA 95076

Log of Test Borings
FORA Road Improvements
Seaside, California

Figure No. 18
Project No. 03102
Date: 02/26/04

LOGGED BY DE DATE DRILLED 1/23/04 BORING DIAMETER 6" SS BORING NO. 13

Depth (feet)	Sample No. and Type	Symbol	Soil Description	Unified Soil Classification	SPT "N" Value	Plasticity Index	Dry Density (pcf)	Moisture % of Dry Wt.	Misc. Lab Results
25	13-5 F	[Symbol]	Light yellowish brown SAND, fine grained sand, moist, dense	SP					
26				31			4.4		
27			Boring Terminated at 26 1/2'						
28									
29									
30									
31									
32									
33									
34									
35									
36									
37									
38									
39									
40									
41									
42									
43									
44									
45									
46									
47									
48									

LOGGED BY DE DATE DRILLED 1/23/04 BORING DIAMETER 6" SS BORING NO. 14

Depth (feet)	Sample No. and Type	Symbol	Soil Description	Unified Soil Classification	SPT "N" Value	Plasticity Index	Dry Density (pcf)	Moisture % of Dry Wt.	Misc. Lab Results
			5" AC						
			3" Base rock						
1	14-1		Dark yellowish brown SAND, fine grained sand, moist, medium dense	SP	19		104.0	4.7	
2	L								
3									
4									
5	14-2		Light yellowish brown SAND, fine grained sand, moist, loose		8		95.0	4.8	
6	L								
7									
8									
9									
10	14-3		Yellowish brown SAND, fine grained sand, moist, medium dense		20			3.1	
11	T								
12			Boring Terminated at 11 1/2'						
13									
14									
15									
16									
17									
18									
19									
20									
21									
22									
23									
24									

LOGGED BY <u>DE</u> DATE DRILLED <u>1/23/04</u> BORING DIAMETER <u>6" SS</u> BORING NO. <u>15</u>									
Depth (feet)	Sample No. and Type	Symbol	Soil Description (Proposed Roadway Cut of 15')	Unified Soil Classification	SPT "N" Value	Plasticity Index	Dry Density (pcf)	Moisture % of Dry Wt.	Misc. Lab Results
			3" AC, 2" Baserock	SP					
1									
2									
3									
4									
5	15-1 T		Yellowish brown SAND, fine grained sand, moist, medium dense		14			4.4	
6									
7									
8									
9									
10	15-2 T		Yellowish brown SAND, fine grained sand, moist, medium dense		23			3.5	
11									
12									
13									
14									
15	15-3 T		Yellowish brown SAND, fine grained sand, moist, medium dense		25			3.7	
16									
17									
18									
19									
20	15-4 T		Yellowish brown SAND with silt, fine grained sand, moist, medium dense		27			4.5	11% Passing #200 Sieve
21									
22									
23									
24									

Pacific Crest Engineering Inc.
444 Airport Blvd., Suite 106
Watsonville, CA 95076

Log of Test Borings
FORA Road Improvements
Seaside, California

Figure No. 21
Project No. 03102
Date: 02/26/04

LOGGED BY <u>DE</u> DATE DRILLED <u>1/23/04</u> BORING DIAMETER <u>6" SS</u> BORING NO. <u>15</u>									
Depth (feet)	Sample No. and Type	Symbol	Soil Description	Unified Soil Classification	SPT "N" Value	Plasticity Index	Dry Density (pcf)	Moisture % of Dry Wt.	Misc. Lab Results
-25	15-5 T		Light yellowish brown SAND, fine grained sand, moist, dense	SP	31			5.0	
-26									
-27	Boring Terminated at 26 1/2'								
-28									
-29									
-30									
-31									
-32									
-33									
-34									
-35									
-36									
-37									
-38									
-39									
-40									
-41									
-42									
-43									
-44									
-45									
-46									
-47									
-48									

Pacific Crest Engineering Inc.
444 Airport Blvd., Suite 106
Watsonville, CA 95076

Log of Test Borings
FORA Road Improvements
Seaside, California

Figure No. 22
Project No. 03102
Date: 02/26/04

LOGGED BY <u>DE</u> DATE DRILLED <u>1/23/04</u> BORING DIAMETER <u>6" SS</u> BORING NO. <u>16</u>									
Depth (feet)	Sample No. and Type	Symbol	Soil Description	Unified Soil Classification	SPT "N" Value	Plasticity Index	Dry Density (pcf)	Moisture % of Dry Wt.	Misc. Lab Results
			2" AC, 2 1/2" Baserock						
1	16-1	[Symbol: Yellowish brown SAND with silt, fine grained sand, moist, medium dense]	Yellowish brown SAND with silt, fine grained sand, moist, medium dense	SP	16		106.7	5.1	10% Passing #200 Sieve
2	L								
3									
4									
5	16-2	[Symbol: Yellowish brown SAND, fine grained sand, moist, medium dense]	Yellowish brown SAND, fine grained sand, moist, medium dense		12		99.1	4.0	
6	L								
7									
8									
9									
10	16-3	[Symbol: Yellowish brown SAND, fine grained sand, moist, medium dense]	Yellowish brown SAND, fine grained sand, moist, medium dense		15			2.9	
11	T								
12		Boring Terminated at 11 1/2'							
13									
14									
15									
16									
17									
18									
19									
20									
21									
22									
23									
24									

Pacific Crest Engineering Inc.
 444 Airport Blvd., Suite 106
 Watsonville, CA 95076

Log of Test Borings
 FORA Road Improvements
 Seaside, California

Figure No. 23
 Project No. 03102
 Date: 02/26/04

LOGGED BY		DE		DATE DRILLED		1/23/04		BORING DIAMETER		6" SS		BORING NO.		17	
Depth (feet)	Sample No. and Type	Symbol	Soil Description	Unified Soil Classification	SPT "N" Value	Plasticity Index	Dry Density (pcf)	Moisture % of Dry Wt.	Misc. Lab Results						
1	17-1 L		3" AC, 4" Baserock	SP	13		104.9	9.5							
2			Light yellowish brown SAND, fine grained sand, moist, medium dense												
3	17-2 L		Light yellowish brown SAND with silt, fine grained sand, moist, medium dense		27		108.9	6.9	12% Passing #200 Sieve						
4															
5															
6															
7	17-3 T		Light yellowish brown SAND, fine grained sand, moist, dense		33			4.4							
8															
9															
10	Boring Terminated at 11 1/2'														
11	Boring Terminated at 11 1/2'														
12	Boring Terminated at 11 1/2'														
13	Boring Terminated at 11 1/2'														
14	Boring Terminated at 11 1/2'														
15	Boring Terminated at 11 1/2'														
16	Boring Terminated at 11 1/2'														
17	Boring Terminated at 11 1/2'														
18	Boring Terminated at 11 1/2'														
19	Boring Terminated at 11 1/2'														
20	Boring Terminated at 11 1/2'														
21	Boring Terminated at 11 1/2'														
22	Boring Terminated at 11 1/2'														
23	Boring Terminated at 11 1/2'														
24	Boring Terminated at 11 1/2'														

Pacific Crest Engineering Inc.
 444 Airport Blvd., Suite 106
 Watsonville, CA 95076

Log of Test Borings
 FORA Road Improvements
 Seaside, California

Figure No. 24
 Project No. 03102
 Date: 02/26/04

LOGGED BY		DE		DATE DRILLED		1/23/04		BORING DIAMETER		6" SS		BORING NO.		18	
Depth (feet)	Sample No. and Type	Symbol	Soil Description				Unified Soil Classification	SPT "N" Value	Plasticity Index	Dry Density (pcf)	Moisture % of Dry Wt.	Misc. Lab Results			
			3 1/2" AC												
			5 1/2" Baserock												
1	18-1		Yellowish brown Silty SAND, fine grained sand, moist, medium dense				SM-SP	12		122.8	9.9	17% Passing #200 Sieve			
2	L														
3															
4															
5	18-2		Yellowish brown SAND, fine grained sand, moist, medium dense					26		118.1	10.7				
6	L														
7															
8															
9			Yellowish brown SAND, fine grained sand, moist, medium dense					21		102.5	6.1				
10	18-3														
11	L														
12															
13			Boring Terminated at 11 1/2'												
14															
15															
16															
17															
18															
19															
20															
21															
22															
23															
24															

Pacific Crest Engineering Inc.
 444 Airport Blvd., Suite 106
 Watsonville, CA 95076

Log of Test Borings
 FORA Road Improvements
 Seaside, California

Figure No. 25
 Project No. 03102
 Date: 02/26/04

LOGGED BY DE DATE DRILLED 2/6/04 BORING DIAMETER 6" SS BORING NO. 19									
Depth (feet)	Sample No. and Type	Symbol	Soil Description (Proposed Roadway Cut of 20')	Unified Soil Classification	SPT "N" Value	Plasticity Index	Dry Density (pcf)	Moisture % of Dry Wt.	Misc. Lab Results
			2" AC						
1			11" Baserock						
2			Yellowish brown SAND, fine grained sand, damp	SP					
3									
4									
5									
6									
7									
8									
9									
10									
11									
12									
13									
14									
15	19-1 L		Light yellowish brown SAND, medium grained sand, damp, medium dense						
16					13		103.9	6.1	
17									
18									
19									
20	19-2 L		Light yellowish brown SAND, medium grained sand, moist, medium dense						
21					17		94.8	3.6	3% Passing #200 Sieve
22									
23									
24									
Pacific Crest Engineering Inc. 444 Airport Blvd., Suite 106 Watsonville, CA 95076			Log of Test Borings FORA Road Improvements Seaside, California			Figure No. 26 Project No. 03102 Date: 02/26/04			

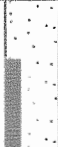
LOGGED BY <u>DE</u> DATE DRILLED <u>2/6/04</u> BORING DIAMETER <u>6" SS</u> BORING NO. <u>19</u>									
Depth (feet)	Sample No. and Type	Symbol	Soil Description	Unified Soil Classification	SPT "N" Value	Plasticity Index	Dry Density (pcf)	Moisture % of Dry Wt.	Misc. Lab Results
25	19-3 L		Light yellowish brown SAND, medium grained sand, moist, medium dense	SP					
26						17		96.1	3.8
27			Boring Terminated at 26 1/2'						
28									
29									
30									
31									
32									
33									
34									
35									
36									
37									
38									
39									
40									
41									
42									
43									
44									
45									
46									
47									
48									

Pacific Crest Engineering Inc.
 444 Airport Blvd., Suite 106
 Watsonville, CA 95076

Log of Test Borings
 FORA Road Improvements
 Seaside, California

Figure No. 27
 Project No. 03102
 Date: 02/26/04

LOGGED BY DE DATE DRILLED 2/6/04 BORING DIAMETER 6" SS BORING NO. 20

Depth (feet)	Sample No. and Type	Symbol	Soil Description (Proposed Roadway Cut of 11')	Unified Soil Classification	SPT "N" Value	Plasticity Index	Dry Density (pcf)	Moisture % of Dry Wt.	Misc. Lab Results
1			1 1/2" AC, 4 1/2" Base rock						
2			Yellowish brown SAND with silt, fine grained sand, damp	SP					
3									
4									
5									
6									
7									
8									
9									
10	20-1 T		Yellowish brown SAND, fine grained sand, damp, medium dense		16			3.9	
11									
12									
13									
14									
15	20-2 L		Yellowish brown SAND, fine grained sand, damp, medium dense		17		98.6	4.8	2% Passing #200 Sieve
16									
17									
18									
19									
20	20-3 L		Yellowish brown SAND, fine grained sand, damp, medium dense		19		100.9	5.5	
21									
22			Boring Terminated at 21 1/2'						
23									
24									

LOGGED BY DE DATE DRILLED 2/6/04 BORING DIAMETER 6" SS BORING NO. 21

Depth (feet)	Sample No. and Type	Symbol	Soil Description (Proposed Roadway Cut of 13')	Unified Soil Classification	SPT "N" Value	Plasticity Index	Dry Density (pcf)	Moisture % of Dry Wt.	Misc. Lab Results
1			2" AC, 4" Baserock						
2			Yellowish brown SAND with silt, fine grained sand, damp	SP					
3									
4									
5									
6									
7									
8									
9									
10	21-1 L		Light yellowish brown SAND, fine grained sand, damp, medium dense		18		105.8	4.3	
11									
12									
13									
14									
15	21-2 L		Light yellowish brown SAND, fine grained sand, damp, medium dense		18		101.1	3.5	3% Passing #200 Sieve
16									
17									
18									
19									
20	21-3 L		Light yellowish brown SAND, fine grained sand, damp, medium dense		18		94.2	3.9	
21									
22									
23									
24									

LOGGED BY <u>DE</u> DATE DRILLED <u>2/6/04</u> BORING DIAMETER <u>6" SS</u> BORING NO. <u>21</u>									
Depth (feet)	Sample No. and Type	Symbol	Soil Description	Unified Soil Classification	SPT "N" Value	Plasticity Index	Dry Density (pcf)	Moisture % of Dry Wt.	Misc. Lab Results
25	21-4 T		Light yellowish brown SAND, fine grained sand, damp, dense	SP	34			3.1	
26									
27	Boring Terminated at 26 1/2'								
28									
29									
30									
31									
32									
33									
34									
35									
36									
37									
38									
39									
40									
41									
42									
43									
44									
45									
46									
47									
48									

Pacific Crest Engineering Inc.
444 Airport Blvd., Suite 106
Watsonville, CA 95076

Log of Test Borings
FORA Road Improvements
Seaside, California

Figure No. 30
Project No. 03102
Date: 02/26/04

LOGGED BY DE DATE DRILLED 2/6/04 BORING DIAMETER 6" SS BORING NO. 22									
Depth (feet)	Sample No. and Type	Symbol	Soil Description (Proposed Roadway Cut of 18')	Unified Soil Classification	SPT "N" Value	Plasticity Index	Dry Density (pcf)	Moisture % of Dry Wt.	Misc. Lab Results
1			2" AC, 4" Base rock	SP					
2									
3									
4			Yellowish brown SAND, fine grained sand, damp						
5									
6									
7									
8									
9				SM-SP					
10	22-1 T		Yellowish brown Silty SAND, fine grained sand, damp, dense		39			5.8	12% Passing #200 Sieve
11									
12									
13									
14									
15									
16									
17									
18									
19									
20	22-2 T		Yellowish brown SAND, fine grained sand, damp, medium dense		28			4.5	
21									
22									
23									
24									

Pacific Crest Engineering Inc.
444 Airport Blvd., Suite 106
Watsonville, CA 95076

Log of Test Borings
FORA Road Improvements
Seaside, California

Figure No. 31
Project No. 03102
Date: 02/26/04

LOGGED BY		DE		DATE DRILLED		2/6/04		BORING DIAMETER		6" SS		BORING NO.		22			
Depth (feet)	Sample No. and Type	Symbol	Soil Description					Unified Soil Classification	SPT "N" Value	Plasticity Index	Dry Density (pcf)	Moisture % of Dry Wt.	Misc. Lab Results				
25	22-3 T	[Symbol]	Yellowish brown SAND, fine grained sand, damp, dense					SP	33				4.2				
26																	
27	Boring Terminated at 26 1/2'																
28																	
29																	
30																	
31																	
32																	
33																	
34																	
35																	
36																	
37																	
38																	
39																	
40																	
41																	
42																	
43																	
44																	
45																	
46																	
47																	
48																	

Pacific Crest Engineering Inc.
 444 Airport Blvd., Suite 106
 Watsonville, CA 95076

Log of Test Borings
 FORA Road Improvements
 Seaside, California

Figure No. 32
 Project No. 03102
 Date: 02/26/04

LOGGED BY DE DATE DRILLED 2/6/04 BORING DIAMETER 6" SS BORING NO. 23

Depth (feet)	Sample No. and Type	Symbol	Soil Description (Proposed Roadway Cut of 7')	Unified Soil Classification	SPT "N" Value	Plasticity Index	Dry Density (pcf)	Moisture % of Dry Wt.	Misc. Lab Results
			1 1/2" AC, 3" Baserock						
1				SP					
2									
3									
4									
5	23-1 L		Yellowish brown SAND, fine grained sand, damp, medium dense		13		96.5	2.5	
6									
7									
8									
9									
10	23-2 L		Yellowish brown SAND, fine grained sand, damp, medium dense		22		104.6	3.9	
11									
12									
13									
14									
15	23-3 L		Yellowish brown SAND, fine grained sand, damp, medium dense		21		107.8	3.7	
16									
17			Boring Terminated at 16 1/2'						
18									
19									
20									
21									
22									
23									
24									

LOGGED BY DE DATE DRILLED 2/6/04 BORING DIAMETER 6" SS BORING NO. 24

Depth (feet)	Sample No. and Type	Symbol	Soil Description (Proposed Roadway Cut of 13')	Unified Soil Classification	SPT "N" Value	Plasticity Index	Dry Density (pcf)	Moisture % of Dry Wt.	Misc. Lab Results
0			2" AC, 4" Baserock						
1				SP					
2									
3									
4			Yellowish brown SAND, fine grained sand, damp						
5									
6									
7									
8									
9				SM					
10	24-1 L		Yellowish brown Silty SAND, fine grained sand, damp, medium dense		18		109.5	7.8	24% Passing #200 Sieve
11									
12									
13									
14				SP					
15	24-2 L		Yellowish brown SAND, fine grained sand, damp, medium dense		19		106.3	6.9	
16									
17			Boring Terminated at 16 1/2'						
18									
19									
20									
21									
22									
23									
24									

LOGGED BY		DE		DATE DRILLED		2/6/04		BORING DIAMETER		6" SS		BORING NO.		25	
Depth (feet)	Sample No. and Type	Symbol	Soil Description (Proposed Roadway Cut of 3')				Unified Soil Classification	SPT "N" Value	Plasticity Index	Dry Density (pcf)	Moisture % of Dry Wt.	Misc. Lab Results			
1	25-1 T		4 1/2" AC, 2" Baserock				SM	27			4.7	12% Passing #200 Sieve			
2			Yellowish brown Silty SAND, fine grained sand, damp, medium dense												
3	25-2 T		Yellowish brown SAND, fine grained sand, damp, medium dense				SP	16			4.2				
4															
5			Yellowish brown SAND, fine grained sand, damp, medium dense												
6	25-3 T		Yellowish brown SAND, fine grained sand, damp, medium dense					18			3.3				
7															
8															
9	Boring Terminated at 11 1/2'														
10															
11															
12															
13															
14															
15															
16															
17															
18															
19															
20															
21															
22															
23															
24															

Pacific Crest Engineering Inc.
444 Airport Blvd., Suite 106
Watsonville, CA 95076

Log of Test Borings
FORA Road Improvements
Seaside, California

Figure No. 35
Project No. 03102
Date: 02/26/04

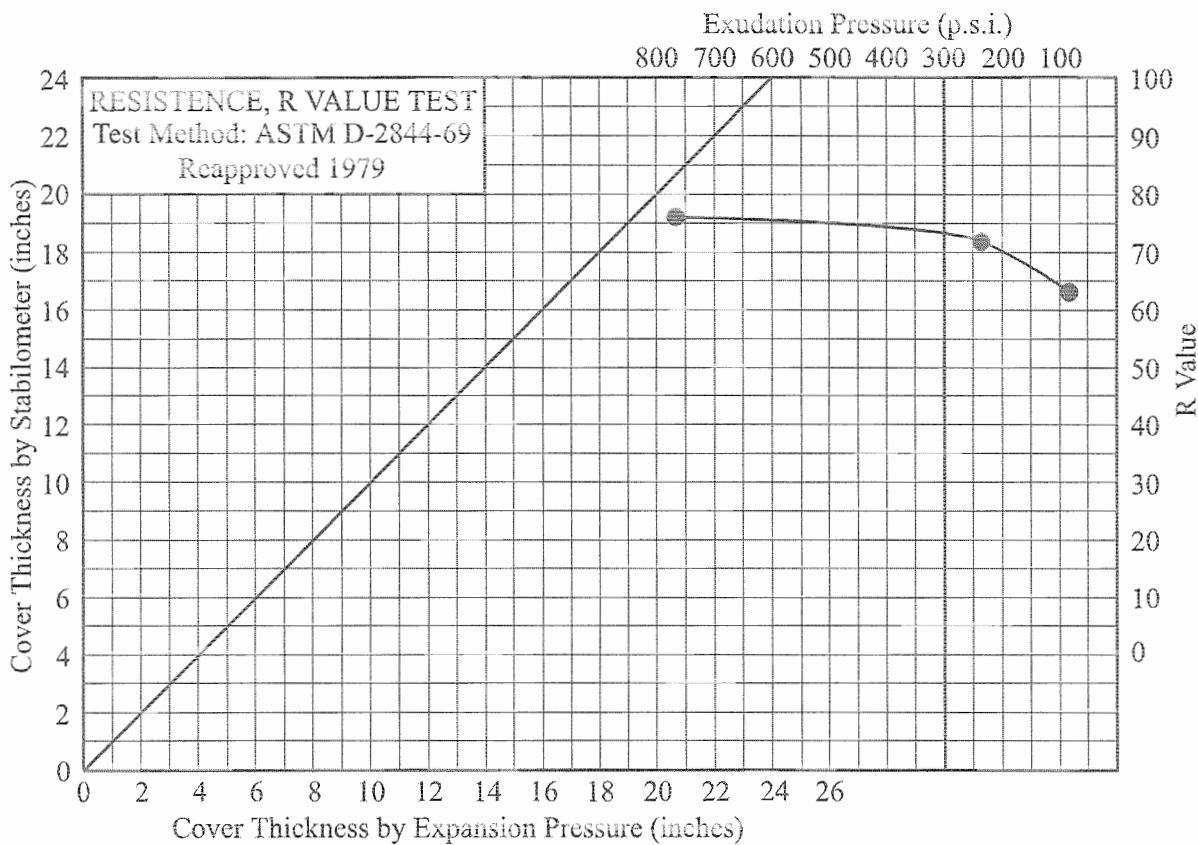

Sample Number: R-1

Sample Description: Brown SAND with silt

Specimen	A	B	C
Exudation Pressure, p.s.i.	81	234	765
Resistance Value, "R"	63	72	76
% Moisture at Test	12.6	10.4	9.5
Dry Density at Test, p.c.f.	115.7	118.6	116.3
R Value at 300 p.s.i. Exudation Pressure	= (73)		

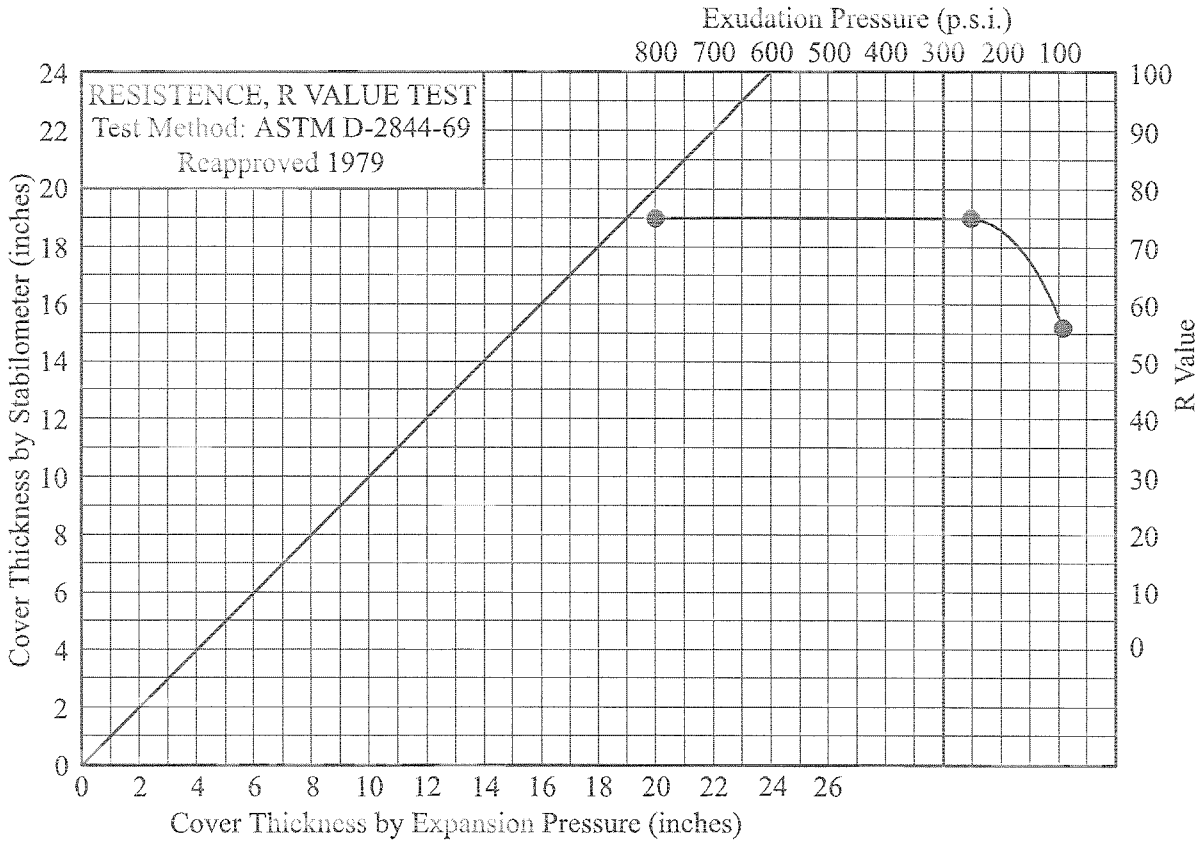

Sample Number: R-2

Sample Description: Brown SAND with silt

Specimen	A	B	C
Exudation Pressure, p.s.i.	91	255	800
Resistance Value, "R"	56	75	75
% Moisture at Test	12.5	10.3	8.9
Dry Density at Test, p.c.f.	116.4	120.2	119.0
R Value at 300 p.s.i. Exudation Pressure	= (75)		

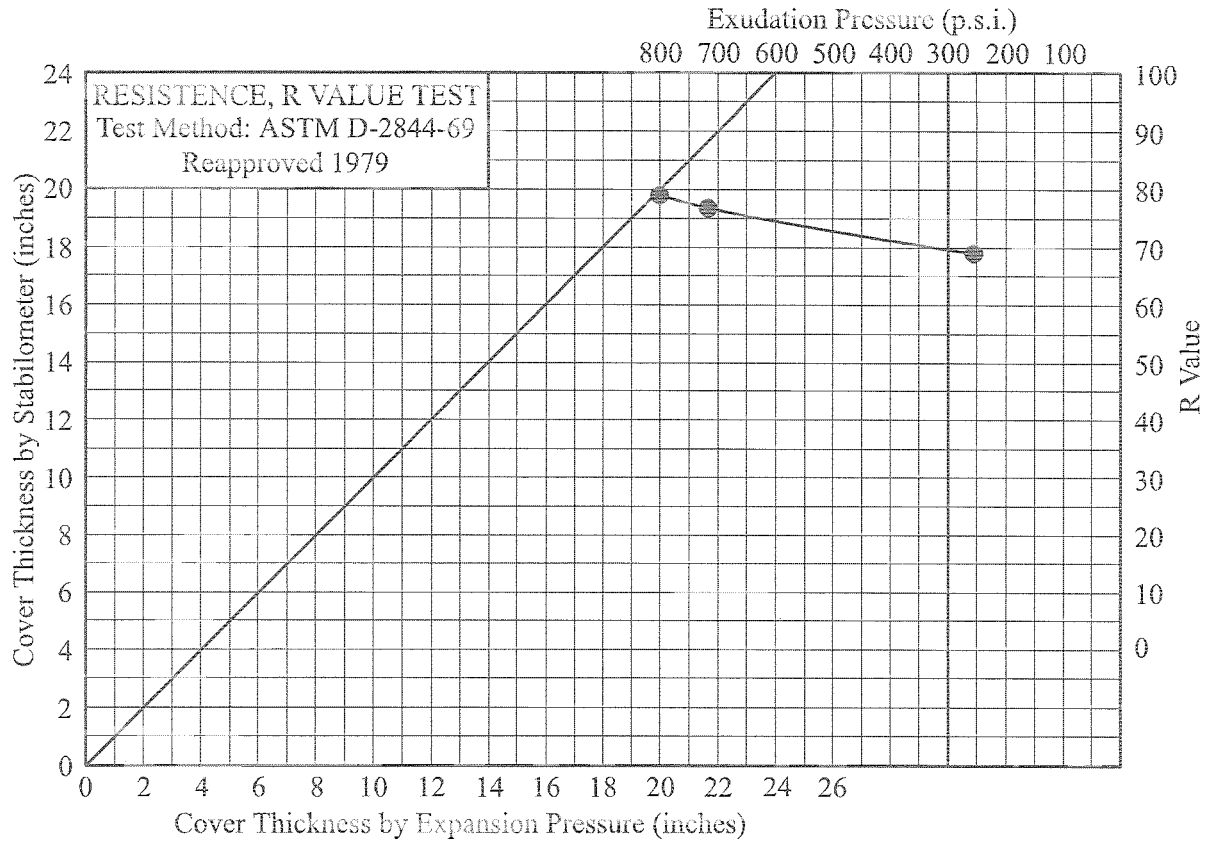

Sample Number: R-3

Sample Description: Yellowish brown SAND with silt

Specimen	A	B	C
Exudation Pressure, p.s.i.	800	254	719
Resistance Value, "R"	79	69	77
% Moisture at Test	9.3	11.1	10.2
Dry Density at Test, p.c.f.	114.0	114.4	113.2
R Value at 300 p.s.i. Exudation Pressure	= (70)		

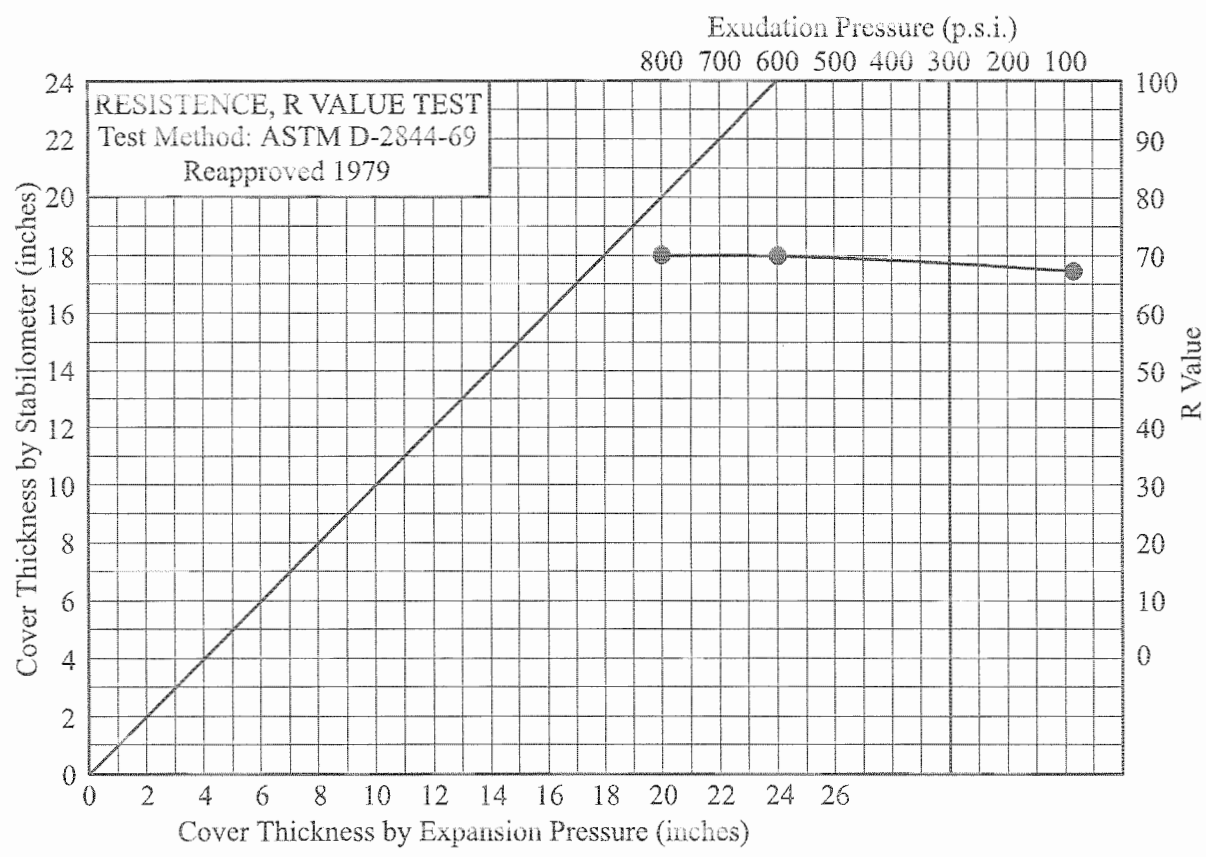

Sample Number: R-4

Sample Description: Orange brown SAND with silt

Specimen	A	B	C
Exudation Pressure, p.s.i.	84	599	800
Resistance Value, "R"	67	70	70
% Moisture at Test	15.7	13.1	11.3
Dry Density at Test, p.c.f.	105.1	106.5	105.5
R Value at 300 p.s.i. Exudation Pressure	= (68)		

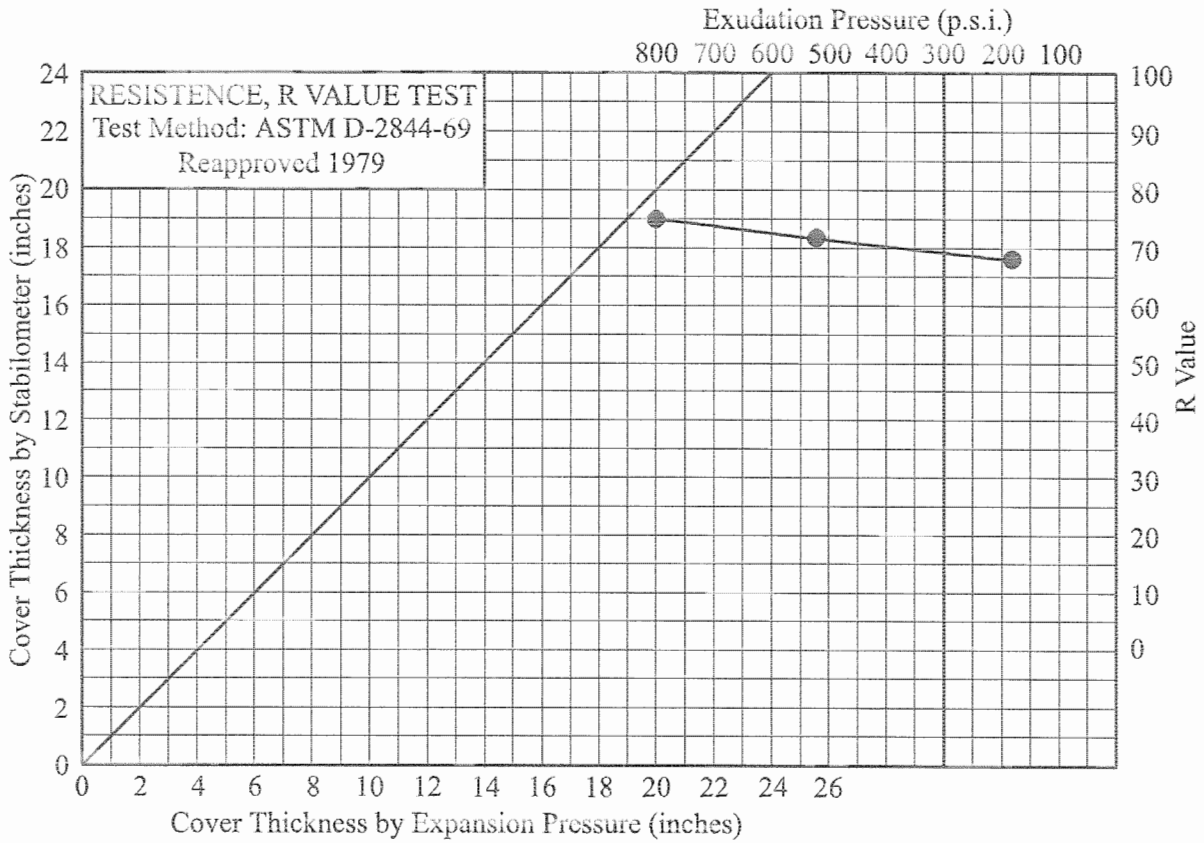

Sample Number: R-5

Sample Description: Yellowish brown SAND with silt

Specimen	A	B	C
Exudation Pressure, p.s.i.	800	521	180
Resistance Value, "R"	75	72	68
% Moisture at Test	13.0	14.4	15.7
Dry Density at Test, p.c.f.	102.8	103.7	102.9
R Value at 300 p.s.i. Exudation Pressure	= (69)		

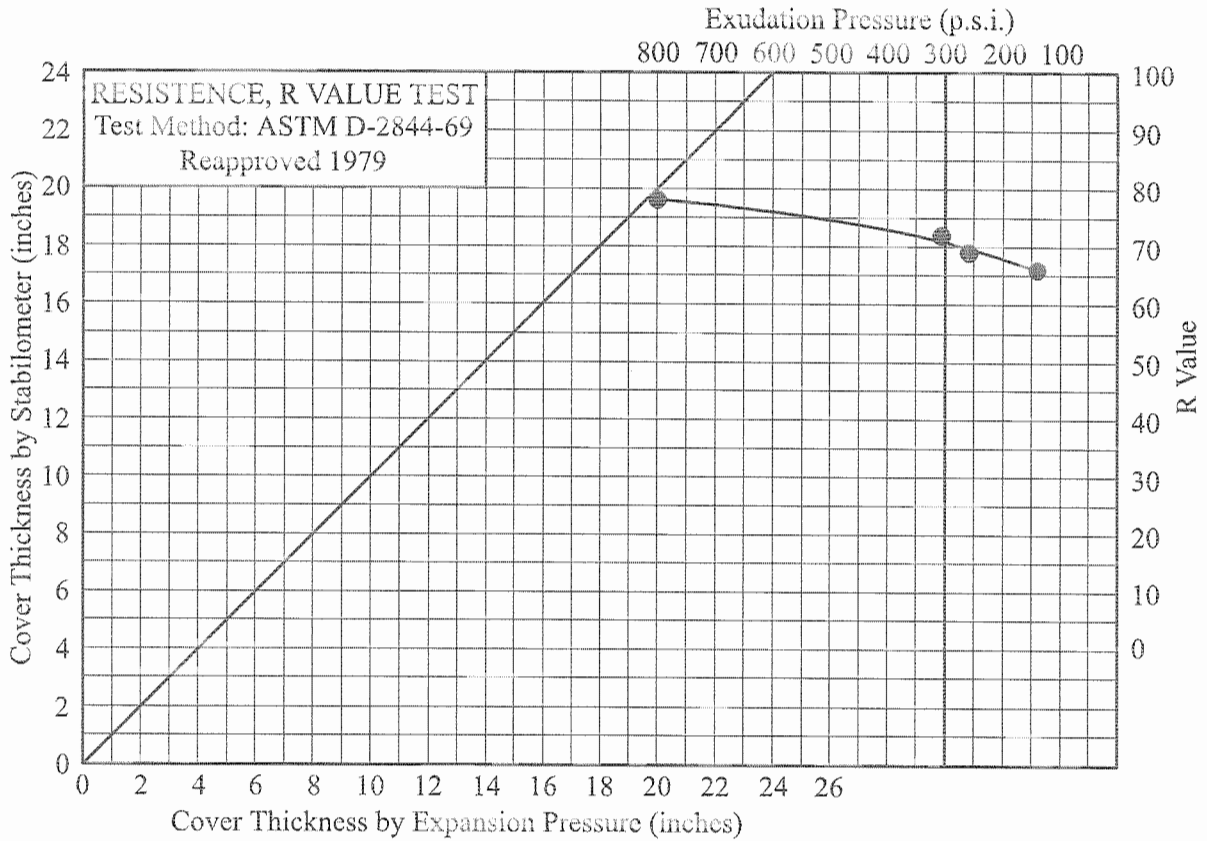

Sample Number: R-6

Sample Description: Yellowish brown SAND with silt

Specimen	A	B	C	D
Exudation Pressure, p.s.i.	139	258	303	800
Resistance Value, "R"	66	69	72	78
% Moisture at Test	14.9	14.0	13.1	12.2
Dry Density at Test, p.c.f.	108.3	107.8	109.1	108.7
R Value at 300 p.s.i. Exudation Pressure	= (71)			

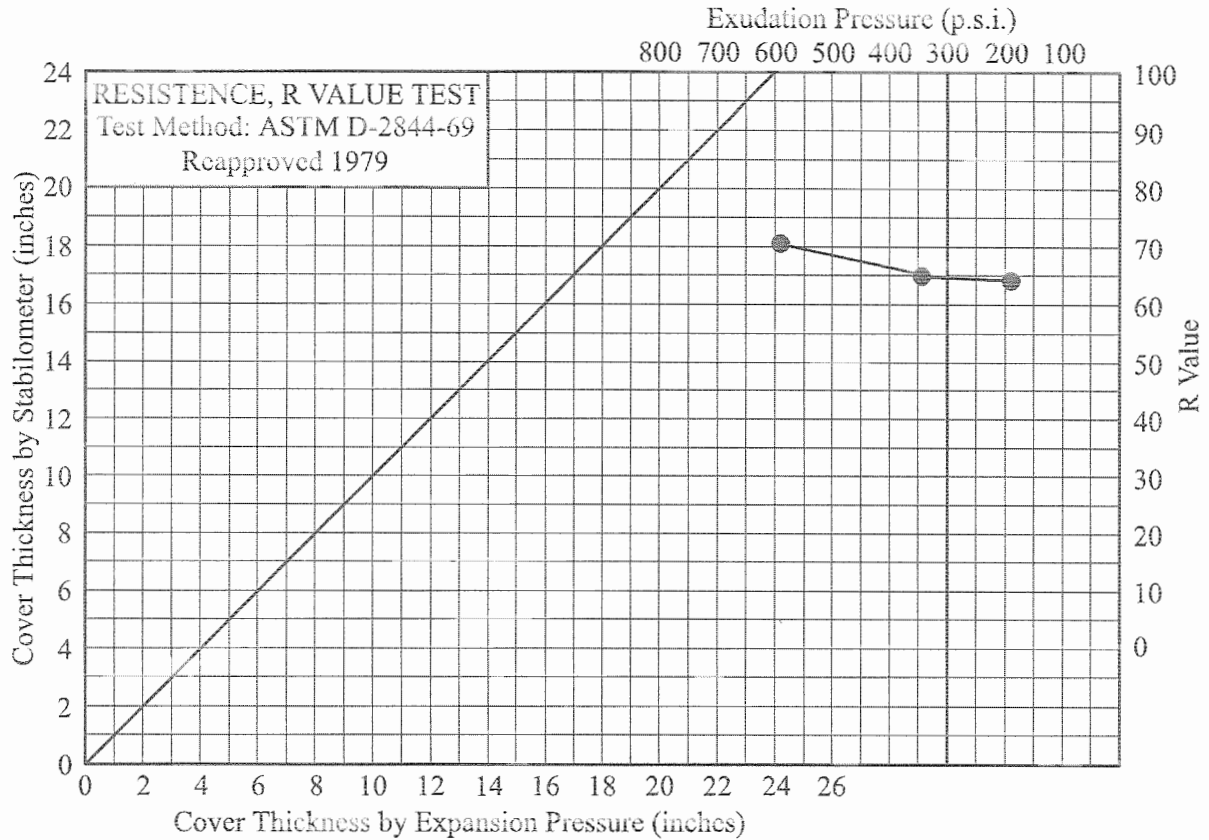

Sample Number: R-7

Sample Description: Tan SAND with silt

Specimen	A	B	C
Exudation Pressure, p.s.i.	185	589	348
Resistance Value, "R"	64	71	65
% Moisture at Test	12.5	11.6	11.9
Dry Density at Test, p.c.f.	101.5	104.7	101.2
R Value at 300 p.s.i. Exudation Pressure	= (64)		

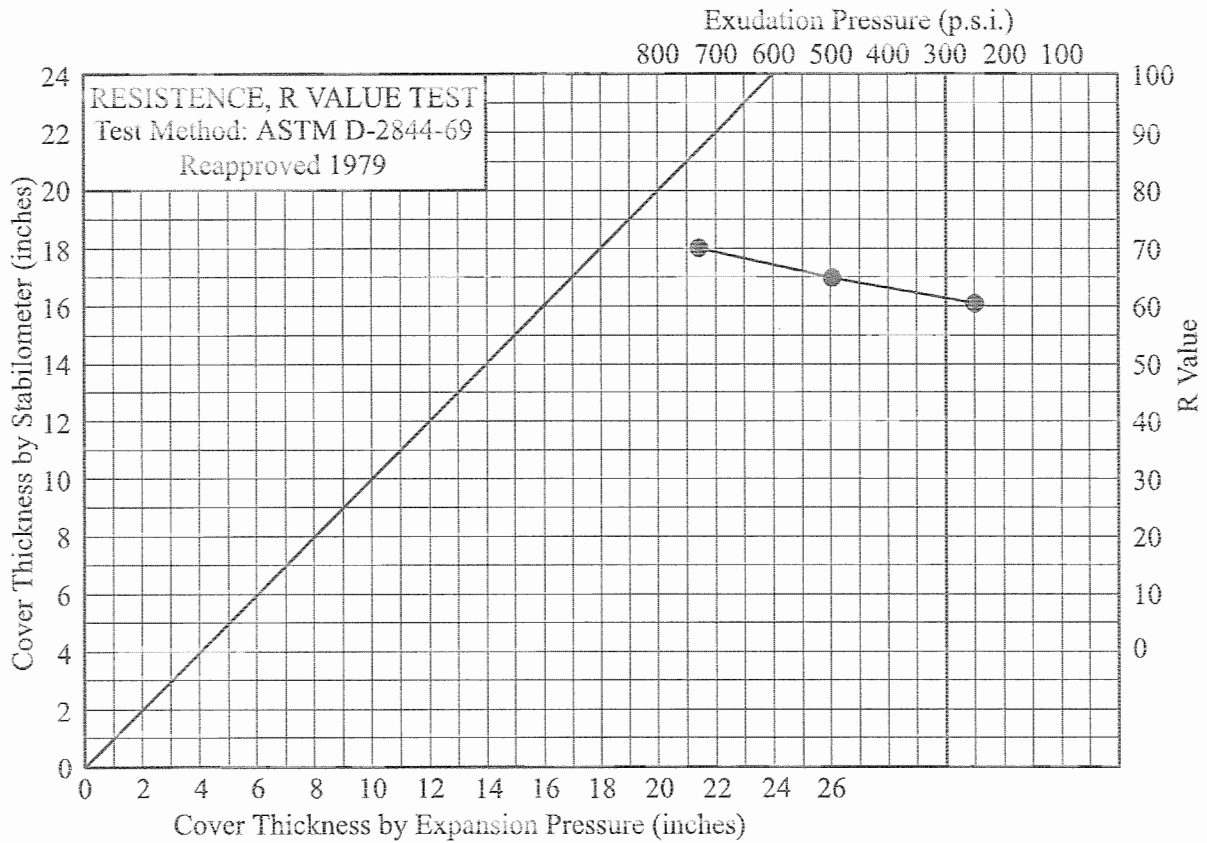

Sample Number: R-8

Sample Description: Tan SAND with silt

Specimen	A	B	C
Exudation Pressure, p.s.i.	727	252	500
Resistance Value, "R"	70	60	65
% Moisture at Test	11.7	12.4	12.0
Dry Density at Test, p.c.f.	105.7	105.8	104.3
R Value at 300 p.s.i. Exudation Pressure	= (61)		

Shaw Group Environmental 2006¹

¹ Please see Figure 5 for full citation.

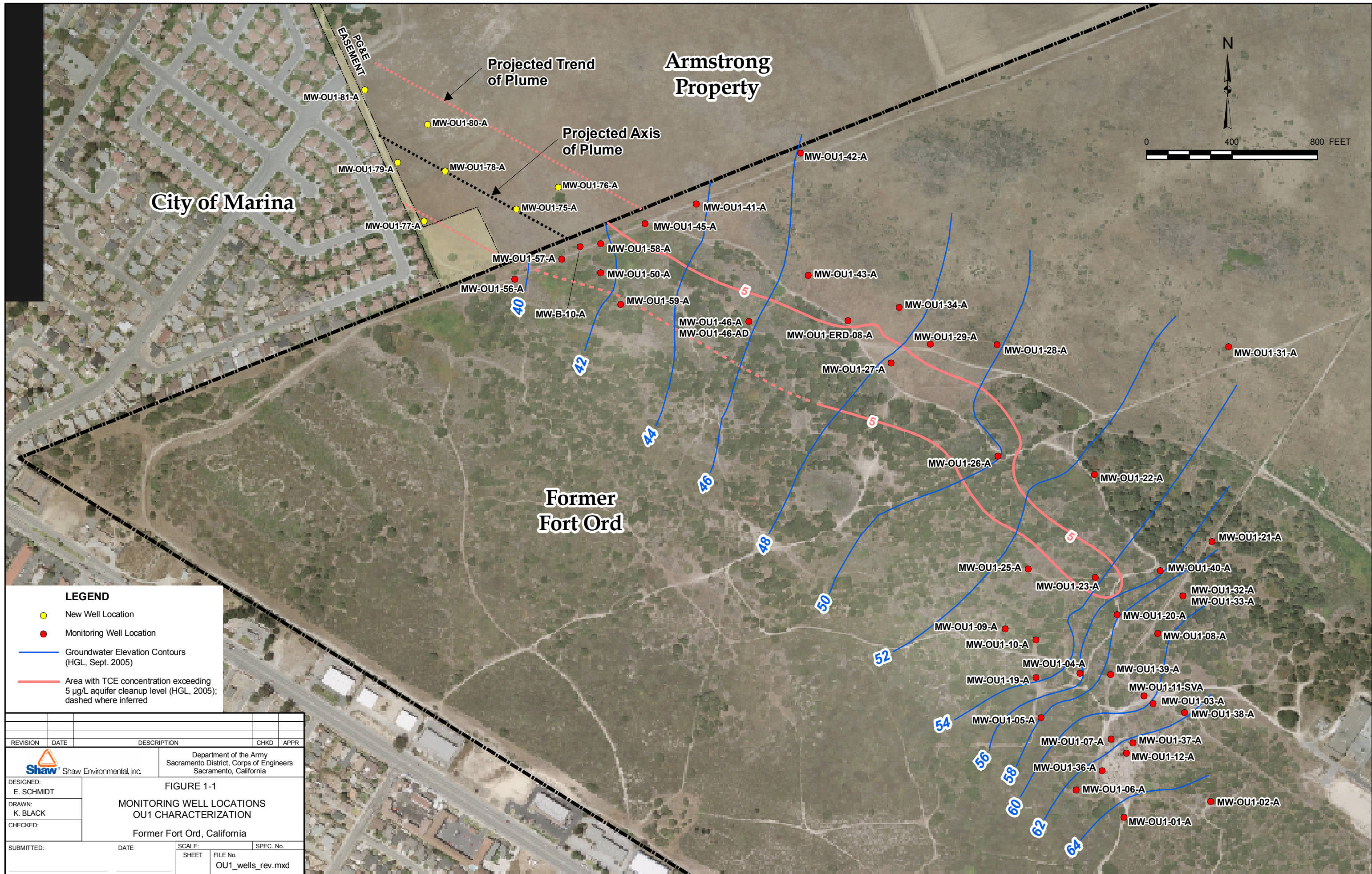

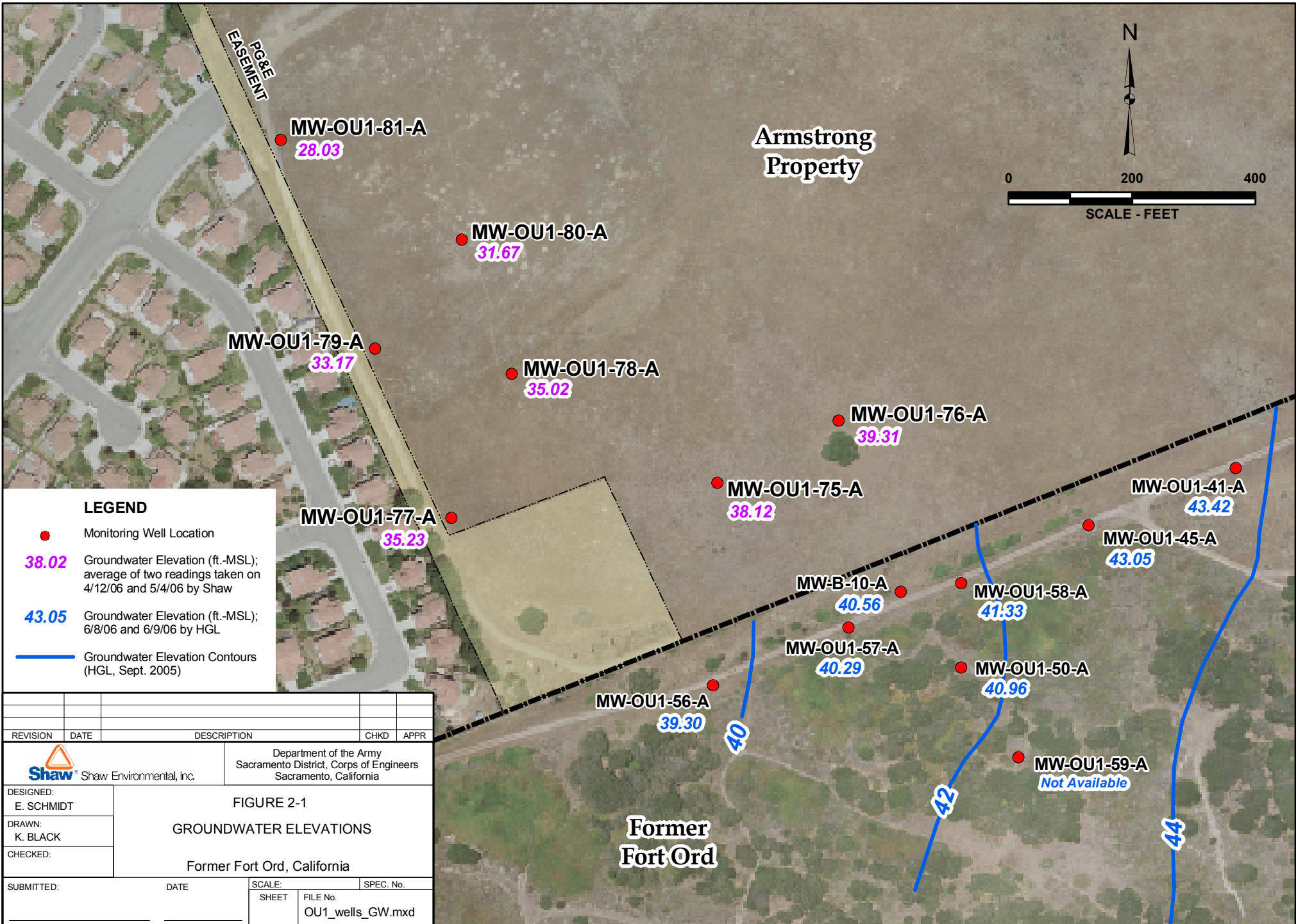

PG&E
EASEMENT

Armstrong
Property

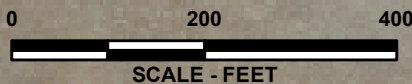

MW-OU1-81-A
28.03

MW-OU1-80-A
31.67

MW-OU1-79-A
33.17

MW-OU1-78-A
35.02

MW-OU1-76-A
39.31

MW-OU1-75-A
38.12

MW-OU1-41-A
43.42

MW-OU1-77-A
35.23

MW-OU1-45-A
43.05

MW-B-10-A
40.56

MW-OU1-58-A
41.33

MW-OU1-57-A
40.29

MW-OU1-50-A
40.96

MW-OU1-56-A
39.30

MW-OU1-59-A
Not Available

Former
Fort Ord

LEGEND

- Monitoring Well Location
- 38.02 Groundwater Elevation (ft.-MSL); average of two readings taken on 4/12/06 and 5/4/06 by Shaw
- 43.05 Groundwater Elevation (ft.-MSL); 6/8/06 and 6/9/06 by HGL
- Groundwater Elevation Contours (HGL, Sept. 2005)

REVISION	DATE	DESCRIPTION	CHKD	APPR
Shaw Environmental, Inc.		Department of the Army Sacramento District, Corps of Engineers Sacramento, California		
DESIGNED:	FIGURE 2-1 GROUNDWATER ELEVATIONS Former Fort Ord, California			
DRAWN:				
CHECKED:				
SUBMITTED:	DATE	SCALE:	SPEC. No.	
		SHEET	FILE No.	
			OU1_wells_GW.mxd	

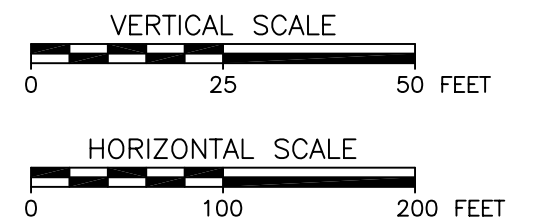
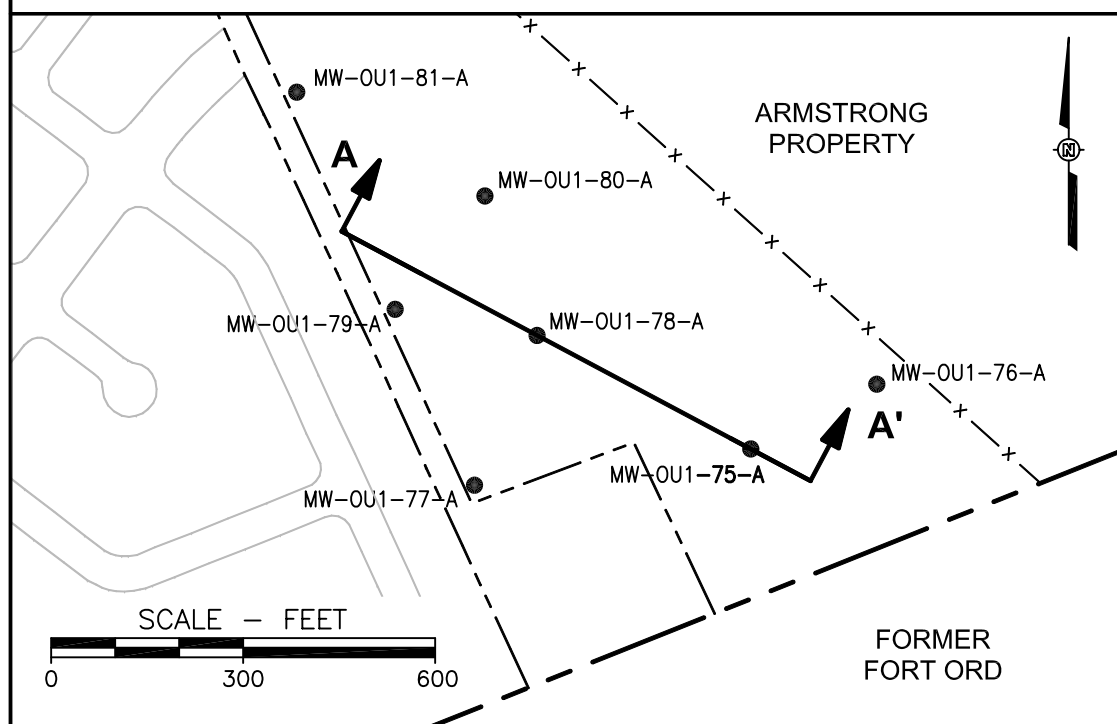
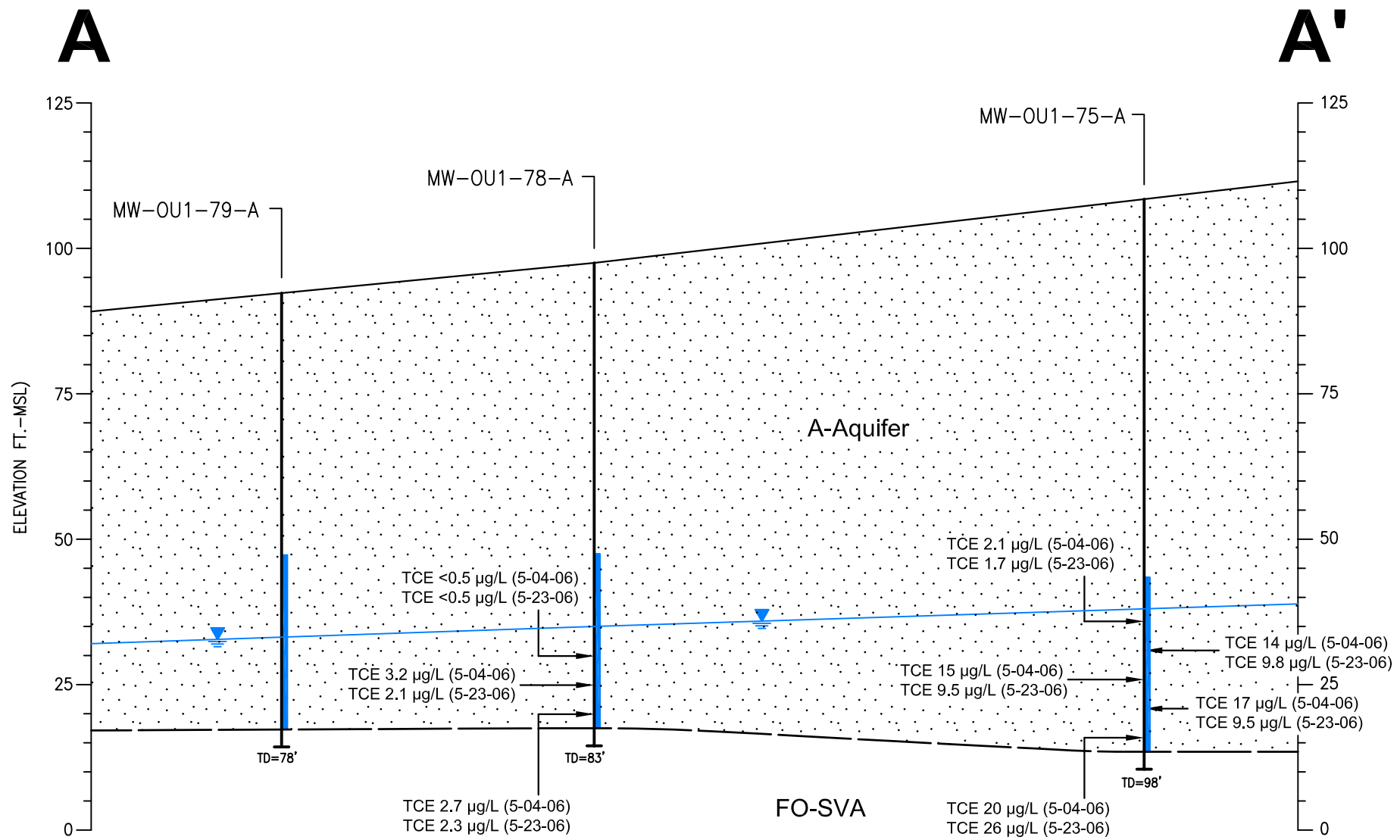

REVISION	DATE	DESCRIPTION	CHKD	APPR

DEPARTMENT OF THE ARMY
 SACRAMENTO DISTRICT, CORPS OF ENGINEERS
 SACRAMENTO, CALIFORNIA

DESIGNED: E. SCHMIDT
 DRAWN: K. BLACK
 CHECKED:

FIGURE 2-2
 CROSS SECTION
 OF NEW OU1 WELLS
 FORMER FORT ORD, CALIFORNIA

SUBMITTED:	DATE APPROVED:	SCALE:	SHEET	SPEC. No.

FILE No. 783751SJ-B178

MONITORING WELL NO. MW-OU1-75-A

COORDINATES: N 2145297.76
E 5745706.69

FIELD GEOLOGIST D. Browne DATE BEGAN 3/14/06
CHECKED BY E. Schmidt DATE FINISHED 3/15/06
APPROVED BY J. Moser SURFACE ELEV. 108.45
TOTAL DEPTH 98 ft. CORE SIZE N/A

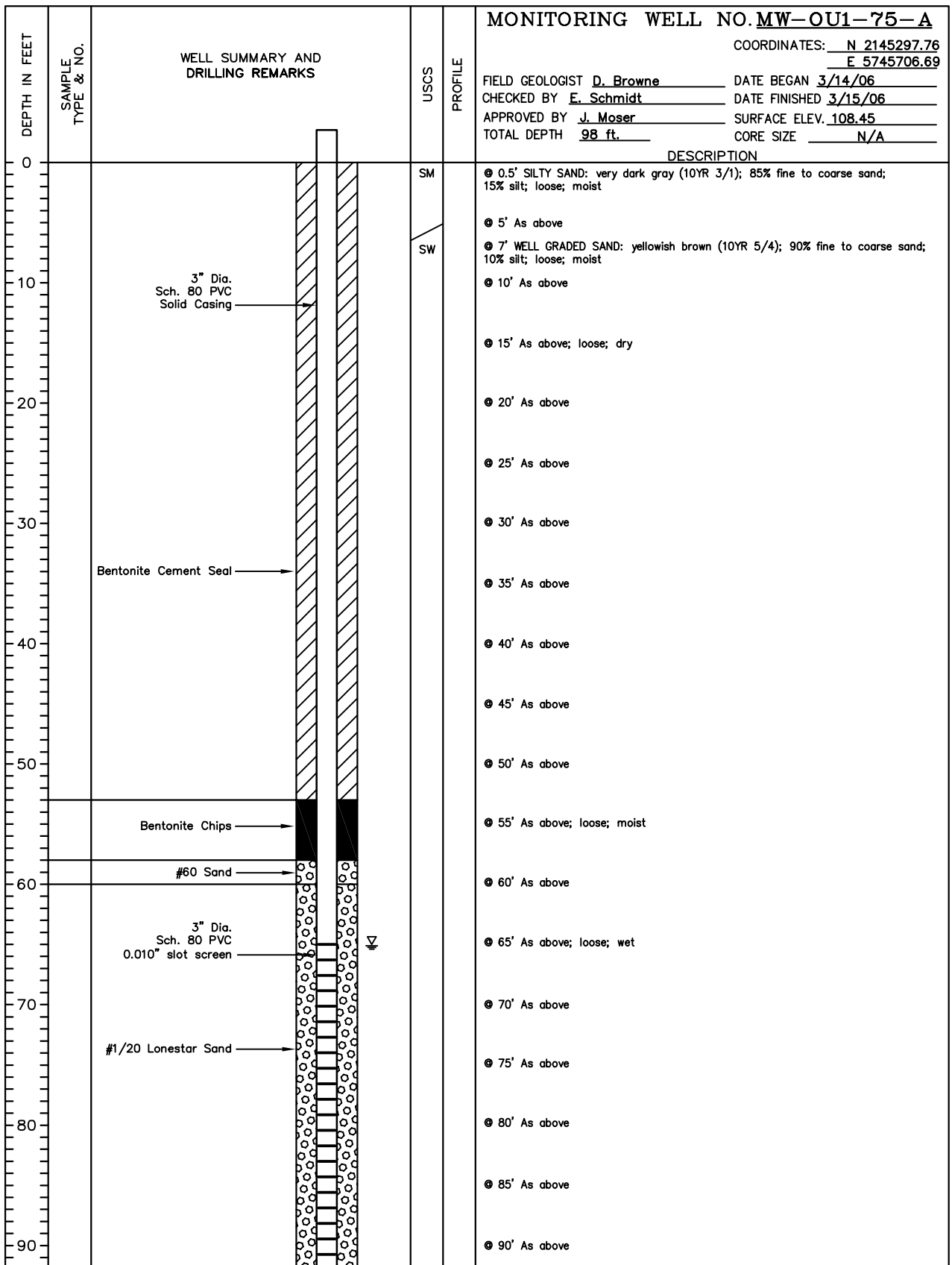

DRILLING CO. : Woodward Drilling
 DRILLING METHOD : 10" Hollow Stem Auger
 LOCATION : OU1 Armstrong Ranch, Former Fort Ord, California
 PROJECT NO. : 783751

DRAWN BY	K. Black	CHECKED BY		FILE NAME & DISK NUMBER	MW-OU1-75-A
DATE	4/18/06	APPROVED BY			



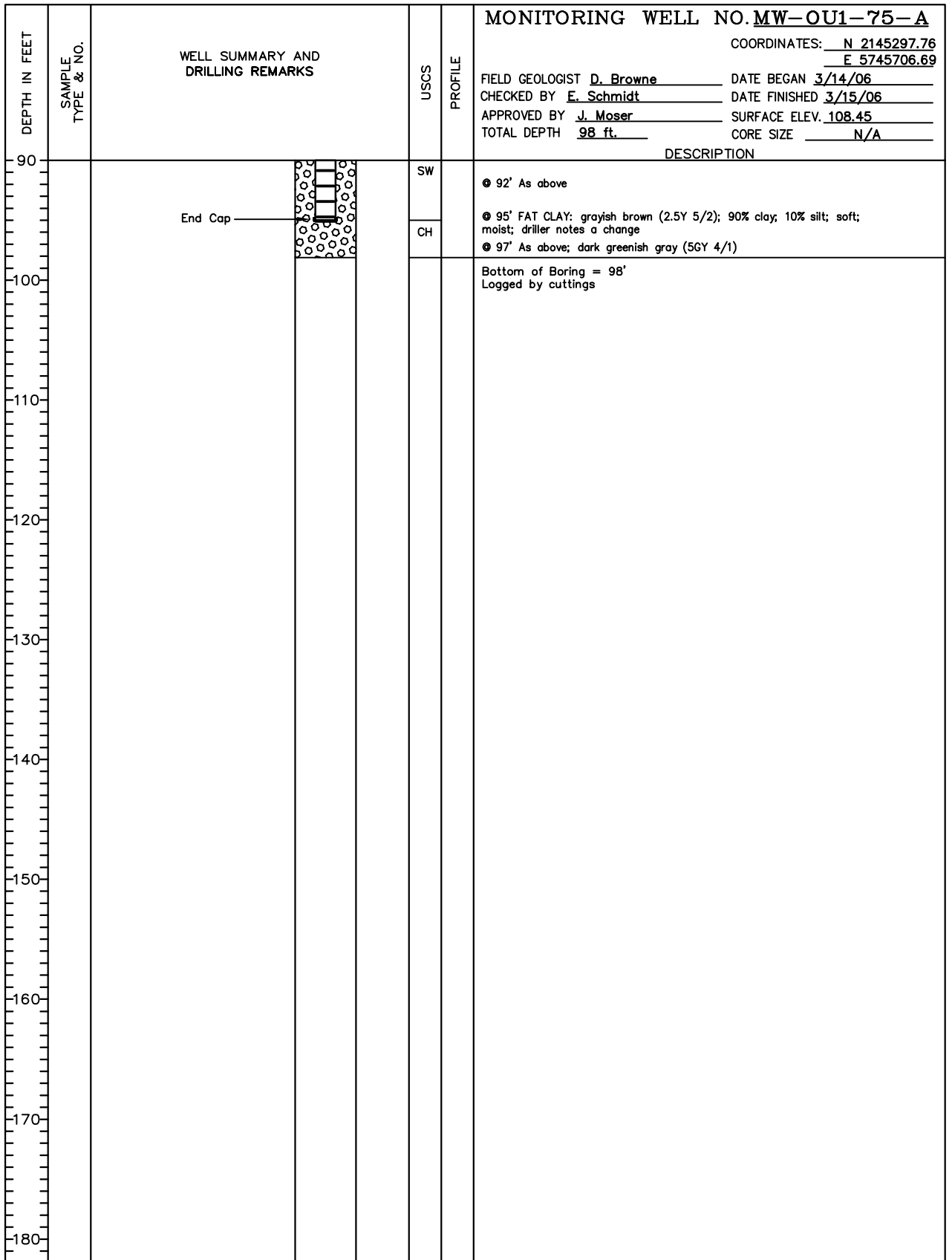

DRILLING CO. : Woodward Drilling
 DRILLING METHOD : 10" Hollow Stem Auger
 LOCATION : OU1 Armstrong Ranch, Former Fort Ord, California
 PROJECT NO. : 783751

DRAWN BY	K. Black	CHECKED BY		FILE NAME & DISK NUMBER	MW-OU1-75-A
DATE	4/18/06	APPROVED BY			



MONITORING WELL NO. MW-OU1-76-A

COORDINATES: N 2145395.27
E 5745912.29

FIELD GEOLOGIST D. Browne DATE BEGAN 3/13/06
CHECKED BY E. Schmidt DATE FINISHED 3/14/06
APPROVED BY J. Moser SURFACE ELEV. 107.41
TOTAL DEPTH 100 ft. CORE SIZE N/A

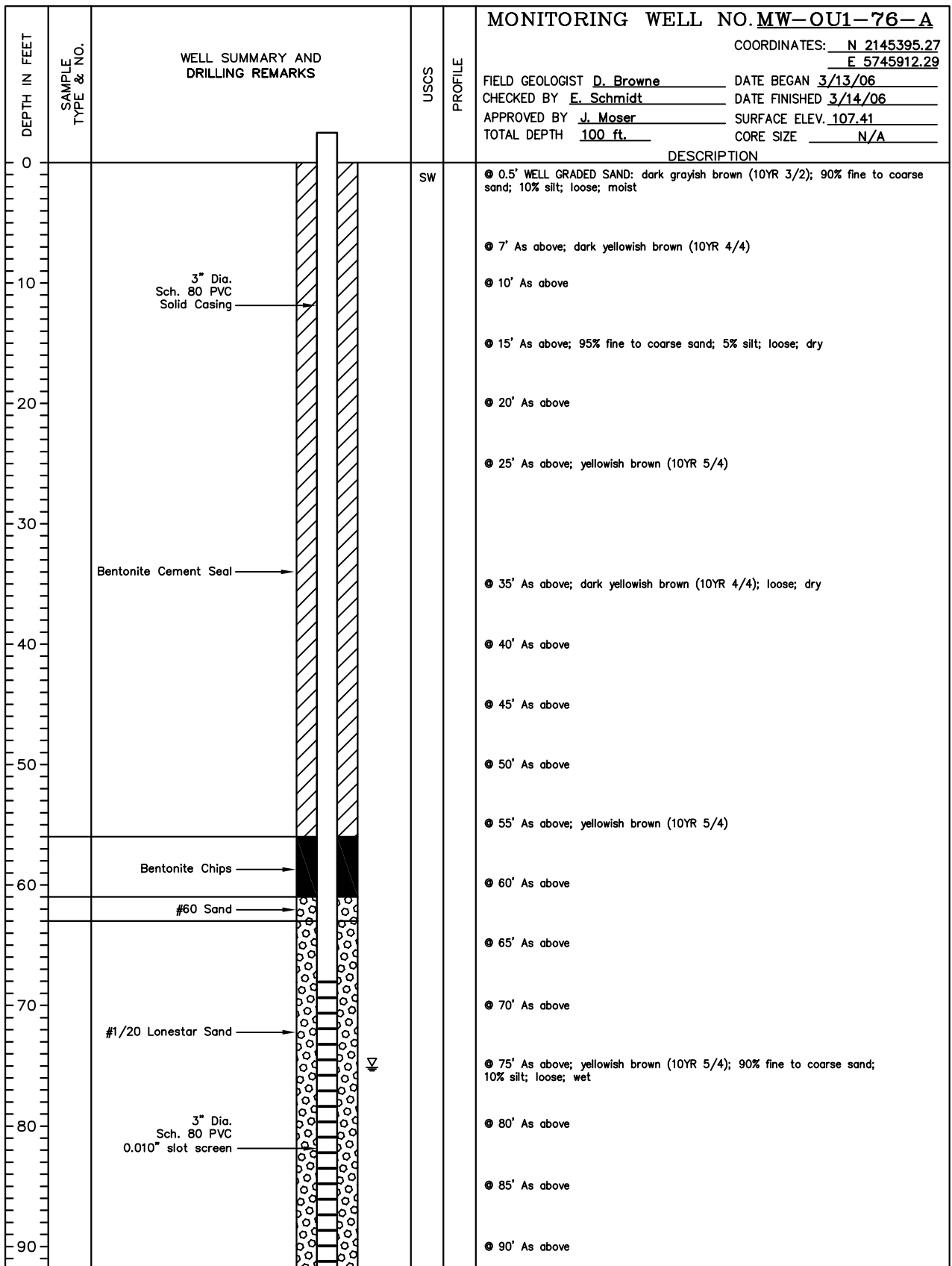

DRILLING CO. : Woodward Drilling
DRILLING METHOD : 10" Hollow Stem Auger
LOCATION : OU1 Armstrong Ranch, Former Fort Ord, California
PROJECT NO. : 783751

DRAWN BY	K. Black	CHECKED BY		FILE NAME & DISK NUMBER	MW-OU1-76-A
DATE	4/18/06	APPROVED BY			



MONITORING WELL NO. MW-OU1-76-A

COORDINATES: N 2145395.27
E 5745912.29

FIELD GEOLOGIST D. Browne DATE BEGAN 3/13/06
CHECKED BY E. Schmidt DATE FINISHED 3/14/06
APPROVED BY J. Moser SURFACE ELEV. 107.41
TOTAL DEPTH 100 ft. CORE SIZE N/A

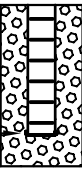
DEPTH IN FEET	SAMPLE TYPE & NO.	WELL SUMMARY AND DRILLING REMARKS	USCS	PROFILE	
90		 <p>#1/20 Lonestar Sand → End Cap →</p>	SW		<p>DESCRIPTION</p> <p>● 95' As above</p> <p>● 97.5' FAT CLAY: grayish brown (2.5Y 5/2); 90% clay; 10% silt; soft; moist; driller notes a change</p>
100			CH		<p>Bottom of Boring = 100' Logged by cuttings</p>
110					
120					
130					
140					
150					
160					
170					
180					

DRILLING CO. : Woodward Drilling
 DRILLING METHOD : 10" Hollow Stem Auger
 LOCATION : OU1 Armstrong Ranch, Former Fort Ord, California
 PROJECT NO. : 783751

DRAWN BY	K. Black	CHECKED BY		FILE NAME & DISK NUMBER	MW-OU1-76-A
DATE	4/18/06	APPROVED BY			



MONITORING WELL NO. MW-OU1-77-A

COORDINATES: N 2145243.17
E 5745276.13

FIELD GEOLOGIST D. Browne DATE BEGAN 3/22/06
CHECKED BY E. Schmidt DATE FINISHED 3/22/06
APPROVED BY J. Moser SURFACE ELEV. 90.68
TOTAL DEPTH 76 ft. CORE SIZE N/A

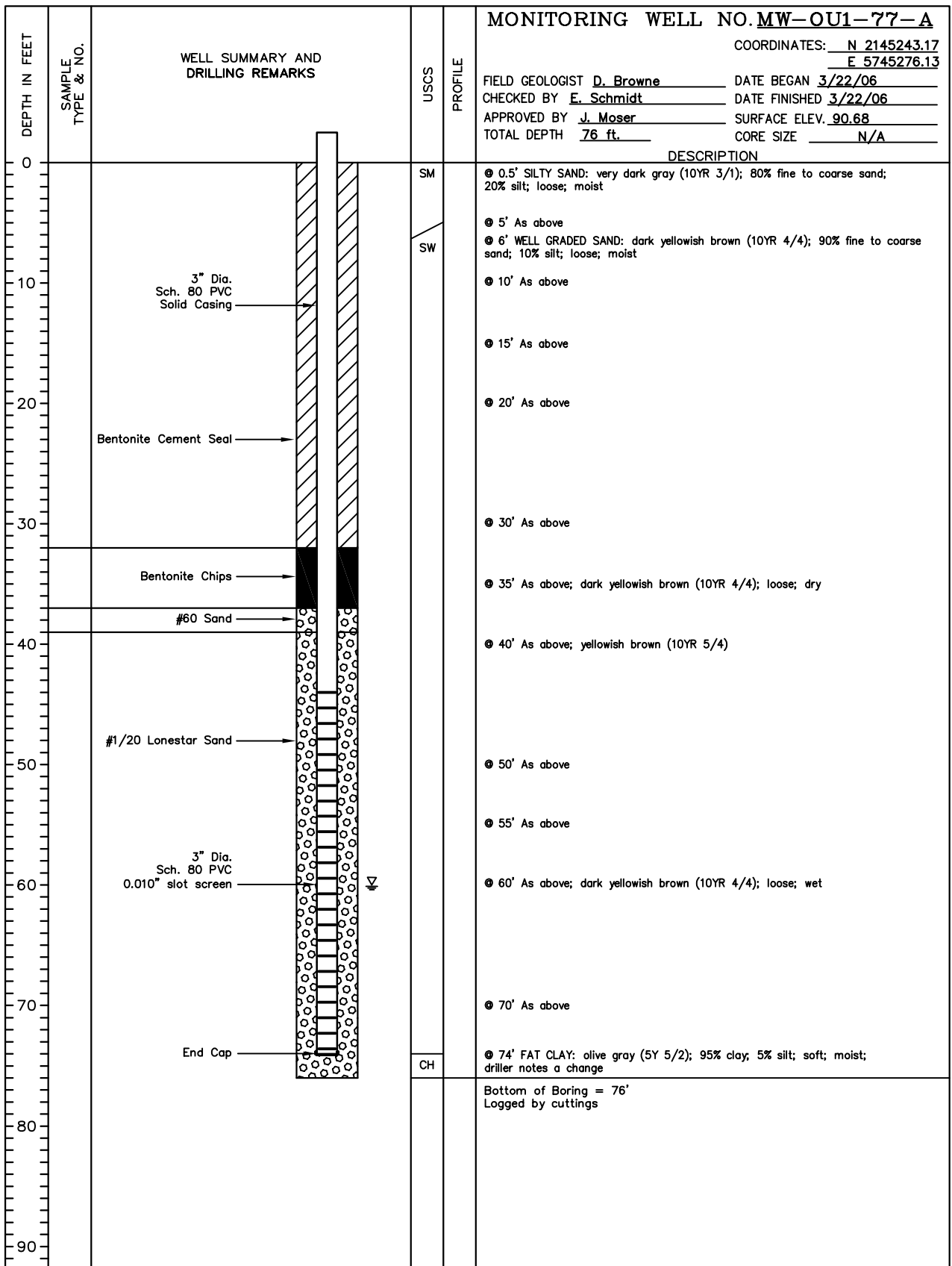

DRILLING CO. : Woodward Drilling
 DRILLING METHOD : 10" Hollow Stem Auger
 LOCATION : OU1 Armstrong Ranch, Former Fort Ord, California
 PROJECT NO. : 783751

DRAWN BY	K. Black	CHECKED BY		FILE NAME & DISK NUMBER	MW-OU1-77-A
DATE	4/18/06	APPROVED BY			



MONITORING WELL NO. MW-OU1-78-A

COORDINATES: N 2145477.85
E 5745372.49

FIELD GEOLOGIST D. Browne DATE BEGAN 3/15/06
CHECKED BY E. Schmidt DATE FINISHED 3/16/06
APPROVED BY J. Moser SURFACE ELEV. 97.49
TOTAL DEPTH 83 ft. CORE SIZE N/A

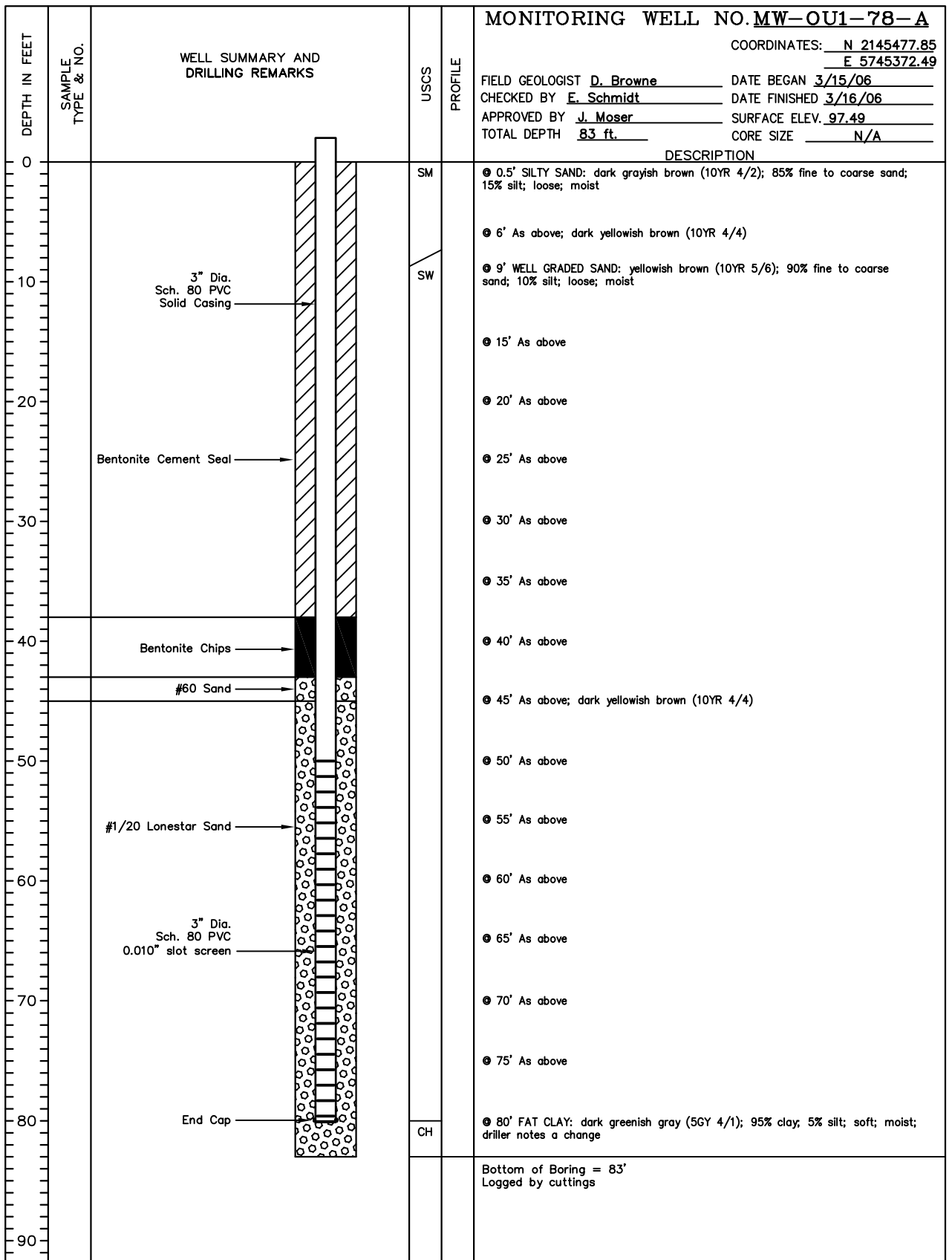

DRILLING CO. : Woodward Drilling
 DRILLING METHOD : 10" Hollow Stem Auger
 LOCATION : OU1 Armstrong Ranch, Former Fort Ord, California
 PROJECT NO. : 783751

DRAWN BY	K. Black	CHECKED BY		FILE NAME & DISK NUMBER	MW-OU1-78-A
DATE	4/18/06	APPROVED BY			



MONITORING WELL NO. MW-OU1-79-A

COORDINATES: N 2145515.23
E 5745150.03

FIELD GEOLOGIST D. Browne DATE BEGAN 3/21/06
CHECKED BY E. Schmidt DATE FINISHED 3/21/06
APPROVED BY J. Moser SURFACE ELEV. 92.30
TOTAL DEPTH 78 ft. CORE SIZE N/A

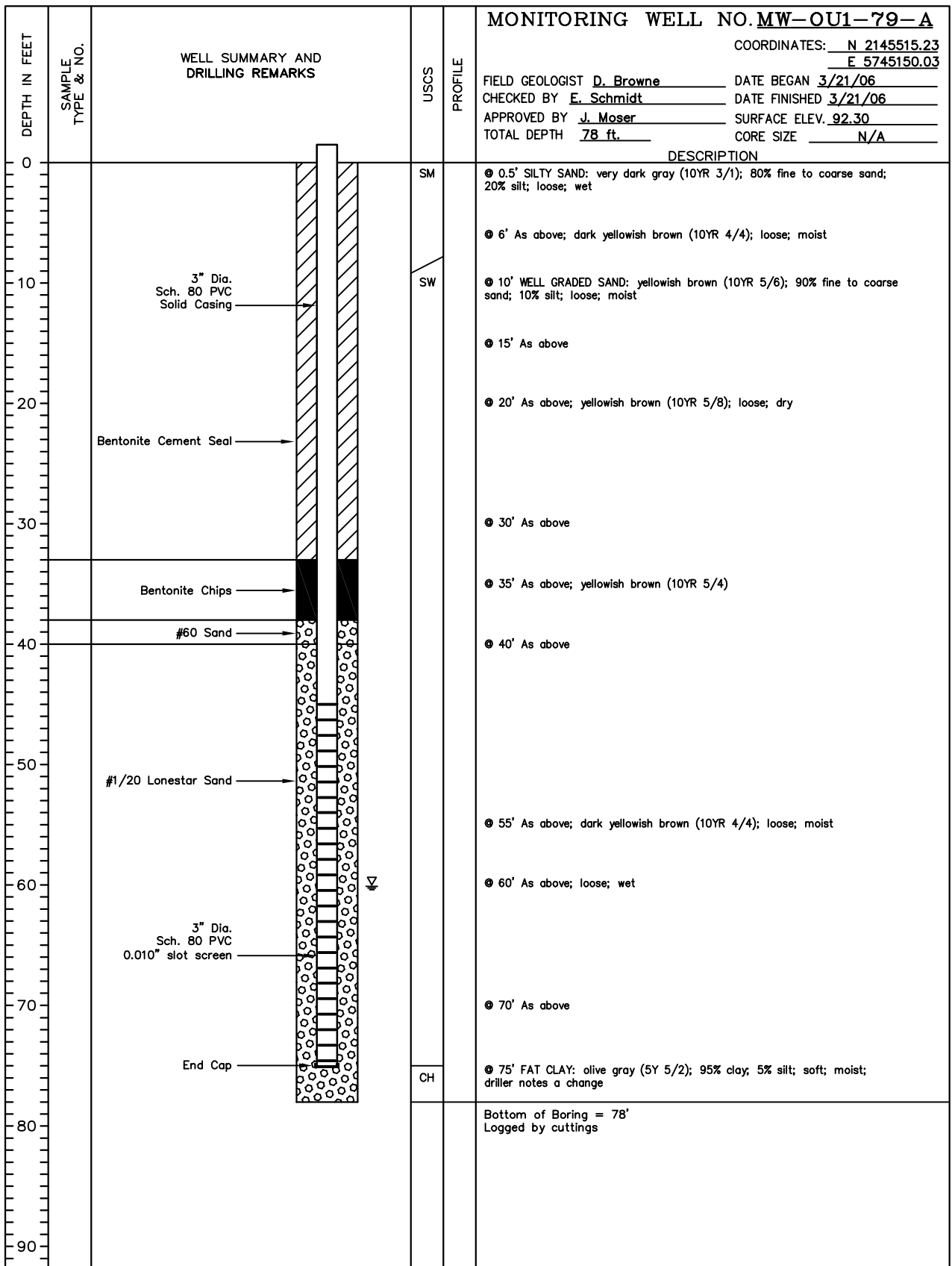

DRILLING CO. : Woodward Drilling
 DRILLING METHOD : 10" Hollow Stem Auger
 LOCATION : OU1 Armstrong Ranch, Former Fort Ord, California
 PROJECT NO. : 783751

DRAWN BY	K. Black	CHECKED BY		FILE NAME & DISK NUMBER	MW-OU1-79-A
DATE	4/18/06	APPROVED BY			



MONITORING WELL NO. MW-OU1-80-A

COORDINATES: N 2145694.84
E 5745290.96

FIELD GEOLOGIST D. Browne DATE BEGAN 3/20/06
CHECKED BY E. Schmidt DATE FINISHED 3/20/06
APPROVED BY J. Moser SURFACE ELEV. 95.90
TOTAL DEPTH 91 ft. CORE SIZE N/A

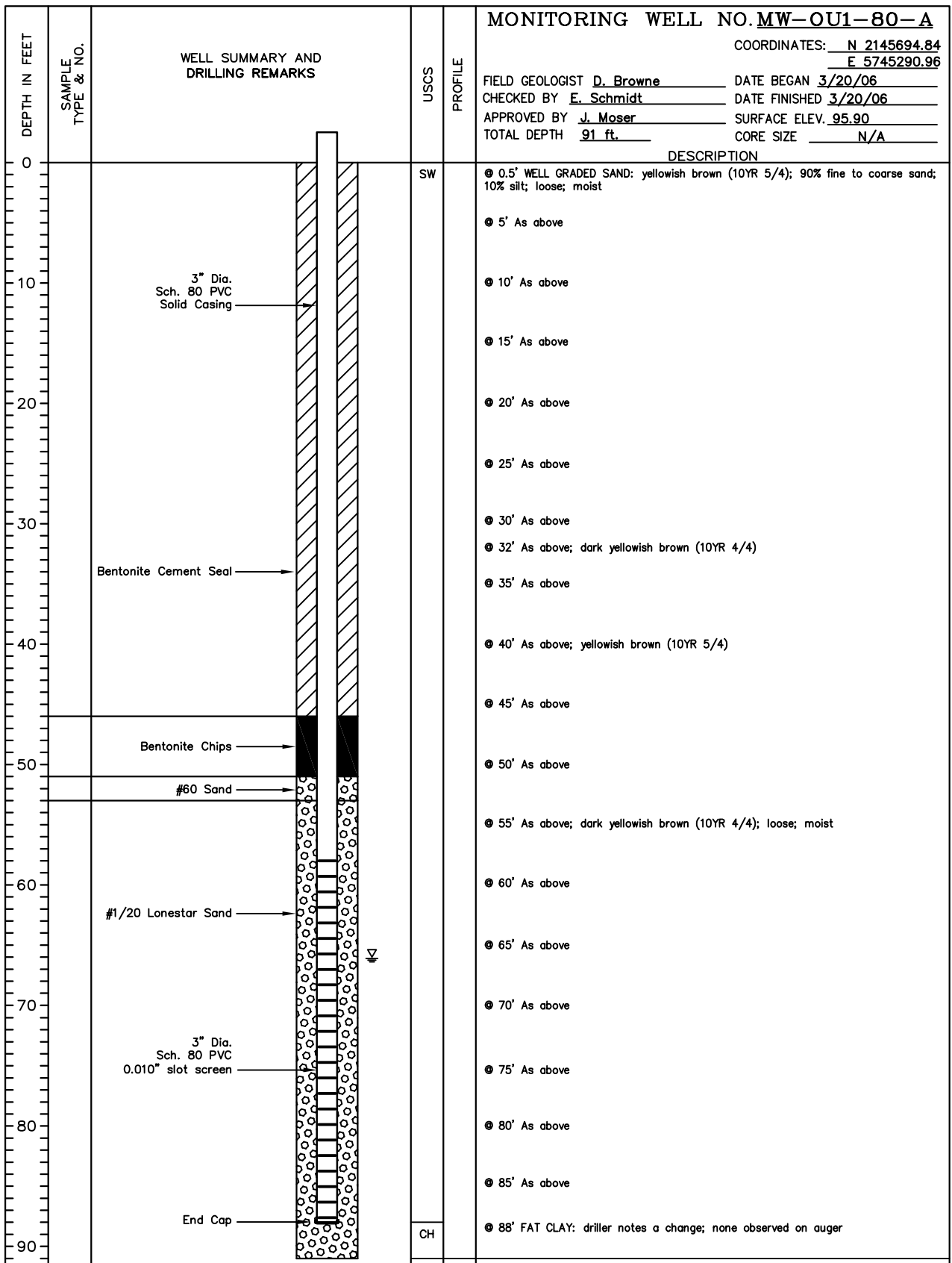

Bottom of Boring = 91'
Logged by cuttings

DRILLING CO. : Woodward Drilling
DRILLING METHOD : 10" Hollow Stem Auger
LOCATION : OU1 Armstrong Ranch, Former Fort Ord, California
PROJECT NO. : 783751

DRAWN BY	K. Black	CHECKED BY		FILE NAME & DISK NUMBER	MW-OU1-80-A
DATE	4/18/06	APPROVED BY			



MONITORING WELL NO. MW-OU1-81-A

COORDINATES: N 2145857.34
E 5744997.04

FIELD GEOLOGIST D. Browne DATE BEGAN 3/21/06
CHECKED BY E. Schmidt DATE FINISHED 3/21/06
APPROVED BY J. Moser SURFACE ELEV. 91.97
TOTAL DEPTH 95 ft. CORE SIZE N/A

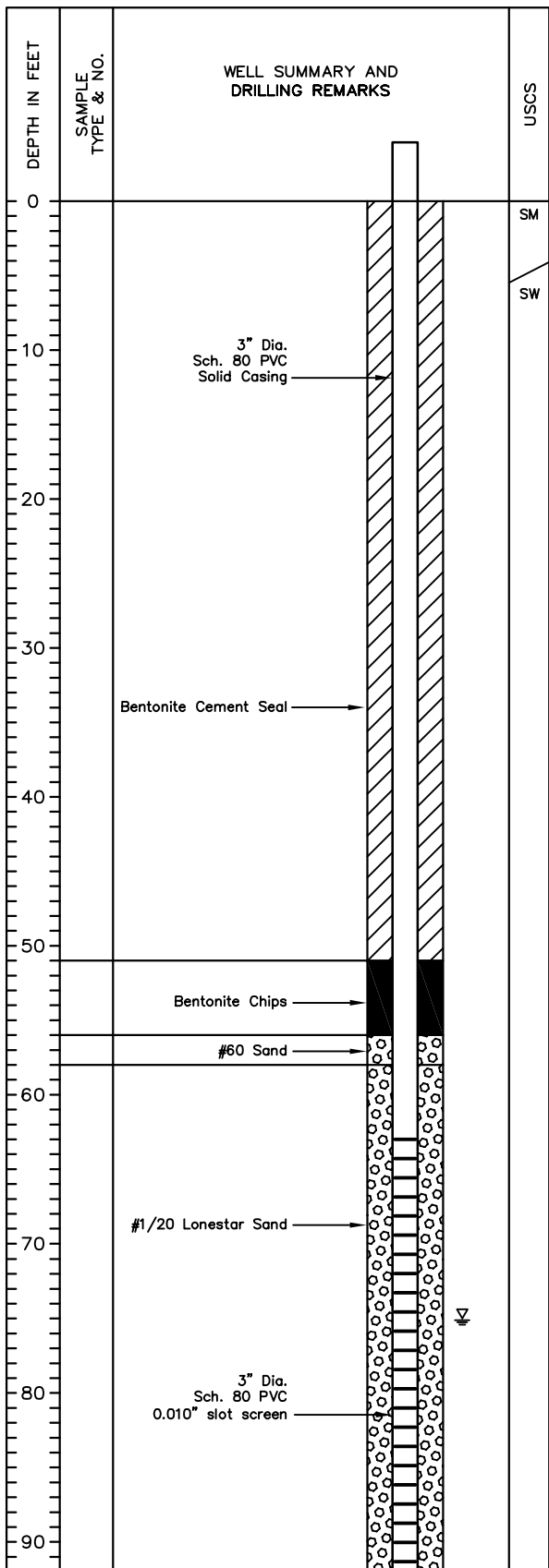

DEPTH IN FEET	SAMPLE TYPE & NO.	WELL SUMMARY AND DRILLING REMARKS	USCS	PROFILE	DESCRIPTION
0			SM		0.5' SILTY SAND: dark grayish brown (10YR 4/2); 85% fine to coarse sand; 15% silt; loose; moist
10			SW		6' WELL GRADED SAND: dark yellowish brown (10YR 4/4); 90% fine to coarse sand; 10% silt; loose; moist
10					10' As above; yellowish brown (10YR 5/4)
15					15' As above; yellowish brown (10YR 5/6); loose; dry
25					25' As above
30					30' As above
35					35' As above; yellowish brown (10YR 5/4)
45					45' As above
50					50' As above; dark yellowish brown (10YR 4/4)
55					55' As above; dark yellowish brown (10YR 5/4); loose; dry
60					60' As above
70					70' As above; loose; moist
75					75' As above; dark yellowish brown (10YR 4/4); loose; wet
85					85' As above
90					90' As above

DRILLING CO. : Woodward Drilling
DRILLING METHOD : 10" Hollow Stem Auger
LOCATION : OU1 Armstrong Ranch, Former Fort Ord, California
PROJECT NO. : 783751

DRAWN BY	K. Black	CHECKED BY		FILE NAME & DISK NUMBER	MW-OU1-81-A
DATE	4/18/06	APPROVED BY			



DEPTH IN FEET	SAMPLE TYPE & NO.	WELL SUMMARY AND DRILLING REMARKS	USCS	PROFILE	MONITORING WELL NO. <u>MW-OU1-81-A</u>	
					COORDINATES: <u>N 2145857.34</u> <u>E 5744997.04</u>	
					FIELD GEOLOGIST <u>D. Browne</u>	DATE BEGAN <u>3/21/06</u>
					CHECKED BY <u>E. Schmidt</u>	DATE FINISHED <u>3/21/06</u>
					APPROVED BY <u>J. Moser</u>	SURFACE ELEV. <u>91.97</u>
					TOTAL DEPTH <u>95 ft.</u>	CORE SIZE <u>N/A</u>
					DESCRIPTION	
90		End Cap 	SW		● 93' FAT CLAY: olive gray (5Y 5/2); 95% clay, 5% silt; medium stiff; moist; driller notes a change	
			CH		Bottom of Boring = 95' Logged by cuttings	
100						
110						
120						
130						
140						
150						
160						
170						
180						

DRILLING CO. : Woodward Drilling
 DRILLING METHOD : 10" Hollow Stem Auger
 LOCATION : OU1 Armstrong Ranch, Former Fort Ord, California
 PROJECT NO. : 783751

DRAWN BY	K. Black	CHECKED BY		FILE NAME & DISK NUMBER	MW-OU1-81-A
DATE	4/18/06	APPROVED BY			





HLA Remedial Investigation Sites¹

- Overview

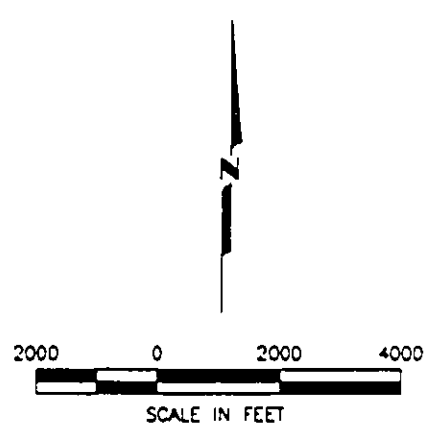
¹ Overview map of 1995 Remedial Investigation Sites of Concern. Please see Figure 5 for full individual site citations.

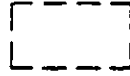
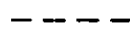

EXPLANATION

	RI SITES
	NPL SITE BOUNDARY
	FORT ORD SITE BOUNDARY

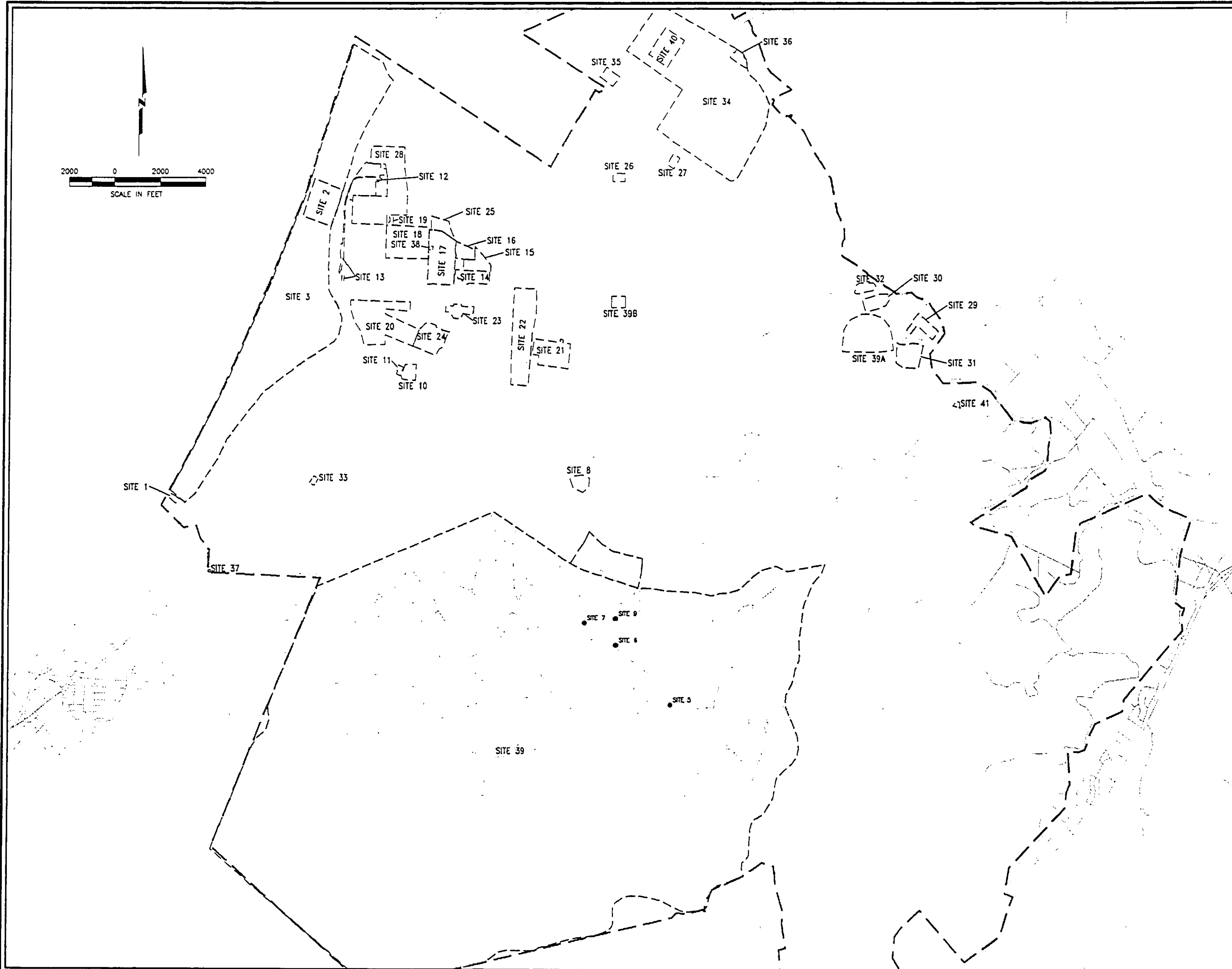

If this image is not as legible as this overlay, it's due to the poor quality of the original document

NO.	DATE	REVISIONS	HLA FILE NO.	PROJECT NO.	APPROVED	APPROVAL DATE	DRAWN BY	 Harding Lawson Associates Engineering and Environmental Services	Volume II - Remedial Investigation Basewide RI/FS Fort Ord, California	Location of RI Sites Introduction to Volume II	PLATE: 1
1	7/94	DRAFT	23366489	23366 041711			KF				
2	12/94	DRAFT FINAL	23366489	23366 041721	BPE	11/22/94	KF				

Site 10^{1,2}

¹ Please see Figure 5 for full citation.

² Boring logs could not be located for this site. Boring locations are provided for reference.

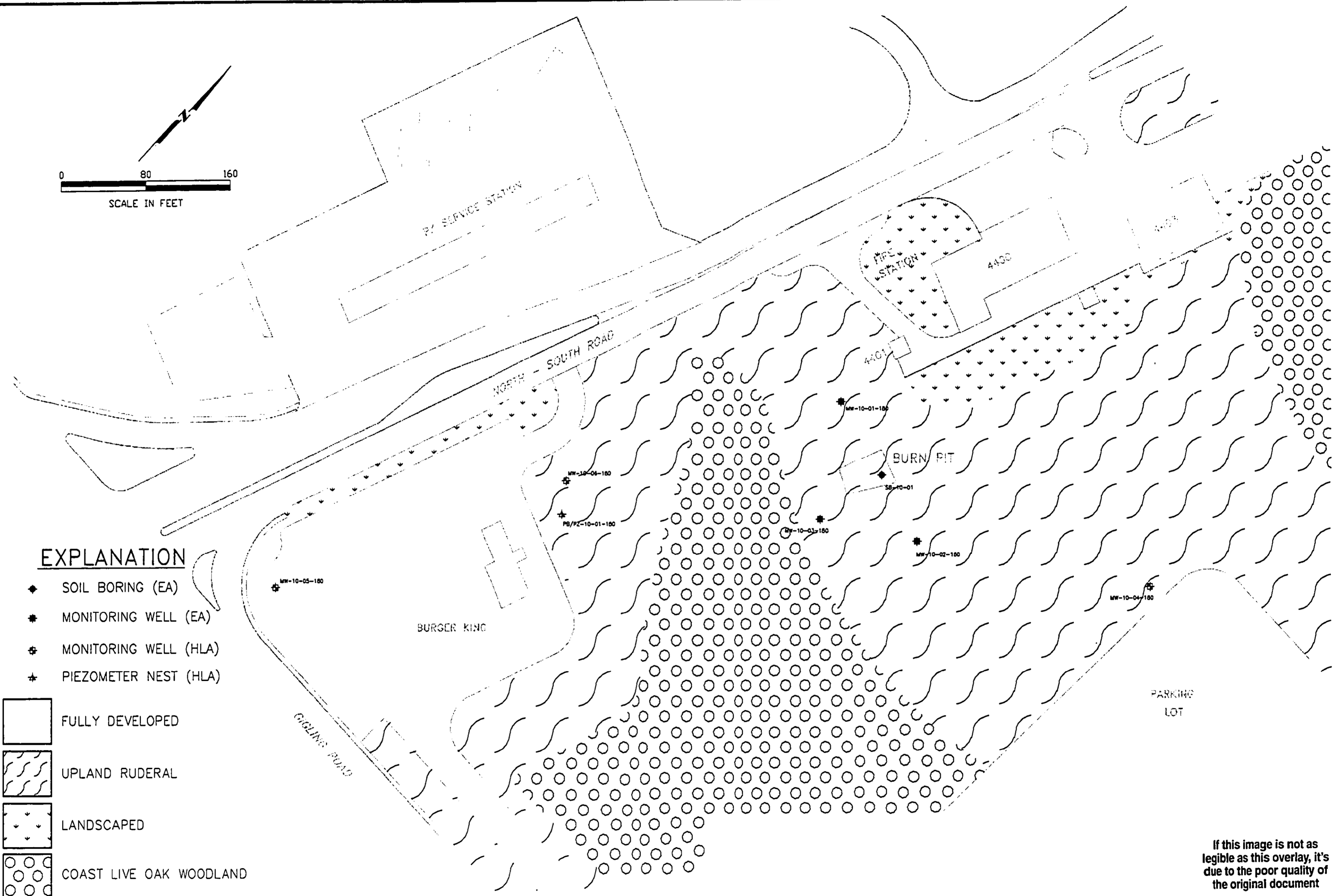
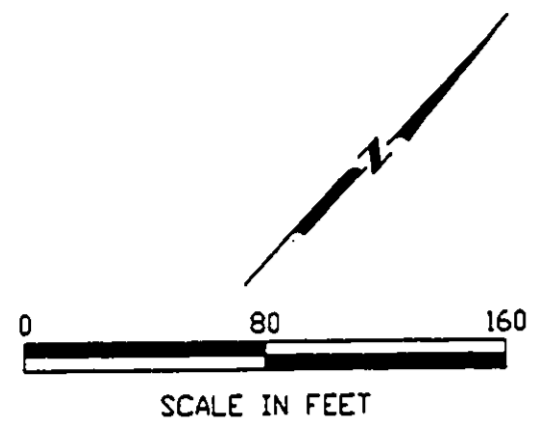

EXPLANATION

- ◆ SOIL BORING (EA)
- MONITORING WELL (EA)
- ⊕ MONITORING WELL (HLA)
- ⊕ PIEZOMETER NEST (HLA)

- FULLY DEVELOPED
- UPLAND RUDERAL
- LANDSCAPED
- COAST LIVE OAK WOODLAND

If this image is not as legible as this overlay, it's due to the poor quality of the original document

NO.	DATE	REVISIONS	HLA FILE NO.	PROJECT NO.	APPROVED	APPROVAL DATE	DRAWN BY	Harding Lawson Associates Engineering and Environmental Services	Volume IV - Ecological Risk Assessment Basewide RI/FS Fort Ord, California	Plant Communities and Sampling Locations Site 10 - Burn Pit	PLATE: 3.3
1	7/11/94	DRAFT	23366288	23366 041714			PH				
2	12/94	DRAFT FINAL	23366288	23366 041724	MES	11/17/94	PH				

23366288 800
199411150937

Site 11¹

¹ Please see Figure 5 for full citation.

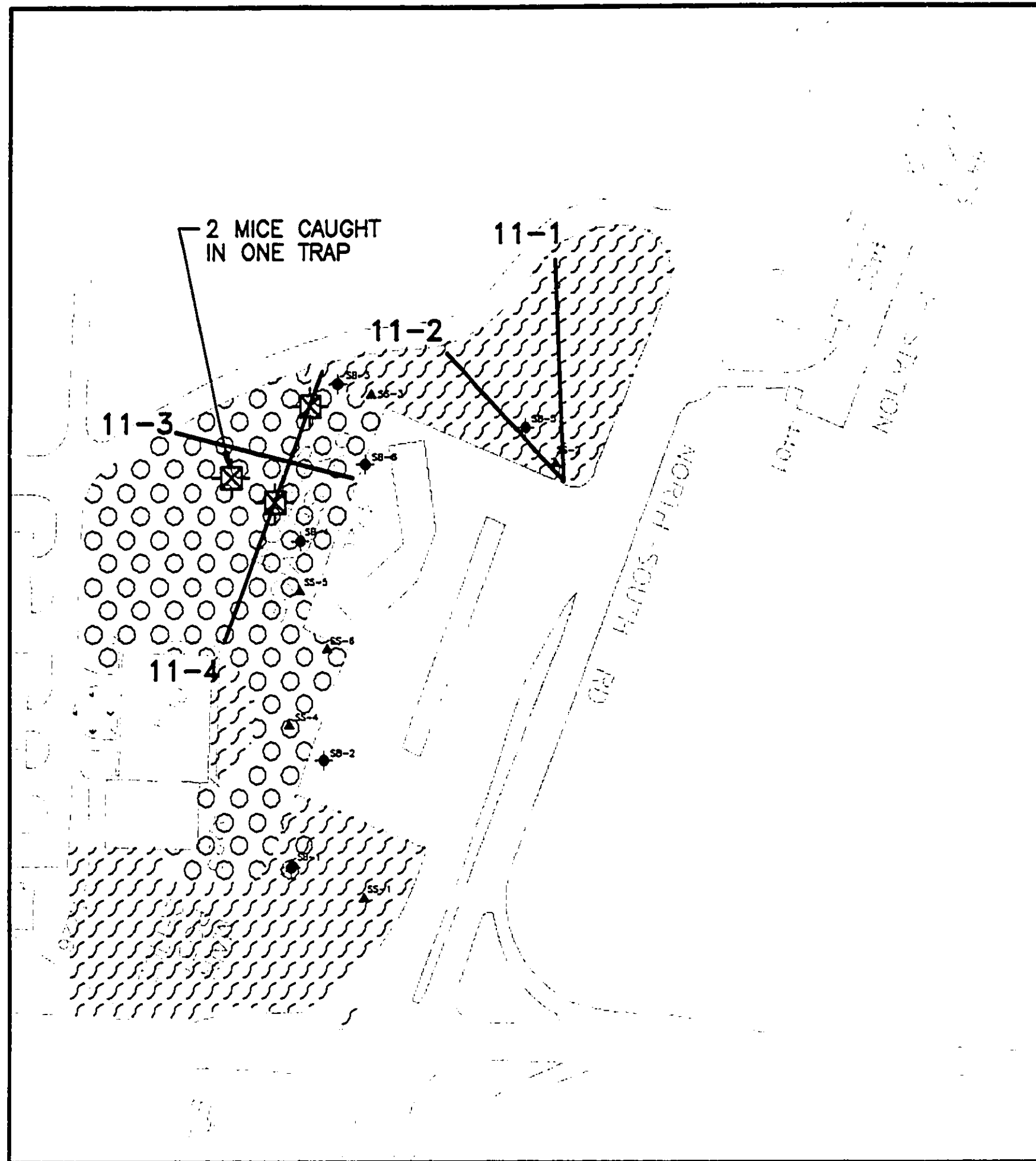

EXPLANATION

- SS-1 ▲ SURFACE SOIL SAMPLE (JMM)
- SB-1 ◆ SOIL BORING (JMM)
- ⊠ RODENT COLLECTION

- FULLY DEVELOPED/NOT SURVEYED
- UPLAND RUDERAL
- LANDSCAPED
- COAST LIVE OAK WOODLAND

11-1 — BIOTA SAMPLING TRANSECT (OATS/ICEPLANT, SOIL, RODENT)

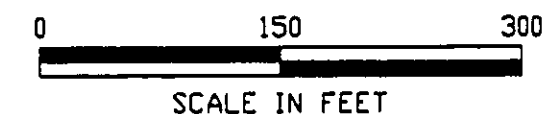

If this image is not as legible as this overlay, it's due to the poor quality of the original document

NO.	DATE	REVISIONS	HLA FILE NO.	PROJECT NO.	APPROVED	APPROVAL DATE	DRAWN BY	Harding Lawson Associates Engineering and Environmental Services		Volume IV - Ecological Risk Assessment Basewide RI/FS Fort Ord, California	Plant Communities and Sampling Locations Site 11 - AAFES Fueling Facility	PLATE: 4.6
1	7/06/94	DRAFT	23366289	23386 041714			AED					
2	12/94	DRAFT FINAL	23366289	23386 041724	MCS	11/12/94	PH					

Recovery (inches)
 OVA Reading (ppm)

0 NA

Depth (ft.)
 Sample

Equipment Hand Auger

3 1/2"-diameter

Elevation _____ Date 3-12-92

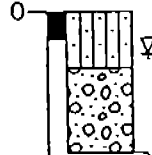

DARK GRAY SILTY SAND (SM): loose, moist

ROCKS, COBBLES FOR EROSION CONTROL (?):
 water seeping in boring

@ 2.5': standing water, boring terminated

Bottom of boring at 2.5 ft.
 Groundwater encountered

5

10

15

20

25

PLATE



Harding Lawson Associates
 Engineering and
 Environmental Services

Log of Boring OF-11-01
 Basewide Surface Water Investigation
 Remedial Investigation
 Fort Ord, California

A 12

DRAWN CEG JOB NUMBER 07579,534.02

APPROVED JDM

DATE 06/92

REVISED DATE

Blows/foot
 Recovery (inches)
 OVA Reading (ppm)
 Sample Number
 9342LBWS

Equipment Hand Auger
3 1/2"-diameter
 Elevation _____ Date 10-18-93

Depth (ft.)
 Sample
 0
 5
 10
 15
 20
 25

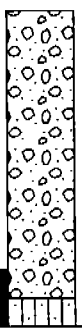

ROCKS AND COBBLES WITH A MATRIX OF DARK GRAY TO BLACK SAND (GW), high organic content

@ 3 feet: dark brown sand (10YR 3/3), no organic content

OLIVE BROWN SILTY SAND (SM) (2.5Y 4/3). 6% silt and clay

Bottom of boring at 5.5 feet.

008F

F.T.O

PLATE



Harding Lawson Associates
 Engineering and
 Environmental Services

Log of Boring OF-11-01
 Basewide Surface Water Investigation
 Volume II-RI, Basewide RI/FS
 Fort Ord, California

A38

DRAWN BWH JOB NUMBER 23366 01834

APPROVED JOM

DATE 02/94

REVISED DATE

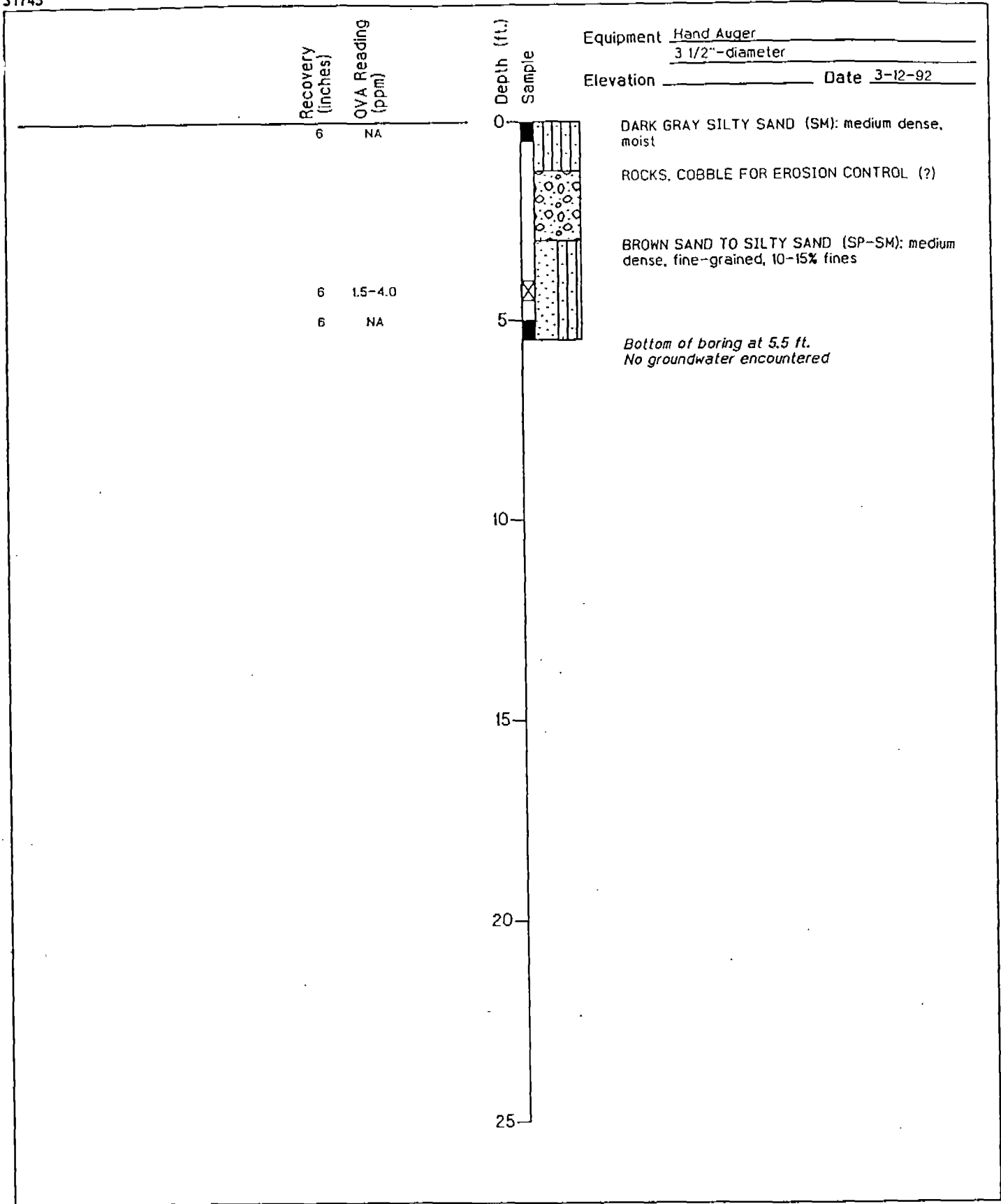

Harding Lawson Associates
 Engineering and
 Environmental Services

Log of Boring OF-11-02
 Basewide Surface Water Investigation
 Remedial Investigation
 Fort Ord, California

PLATE

A 13

DRAWN CEG JOB NUMBER 07579,534.02

APPROVED JDM

DATE 06/92

REVISED DATE

U S Standard Sieve Size (in) U S Standard Sieve Numbers Hydrometer

3 1½ ¾ ⅜ 4 8 16 30 40 50 100 200

Reference ASTM D 422

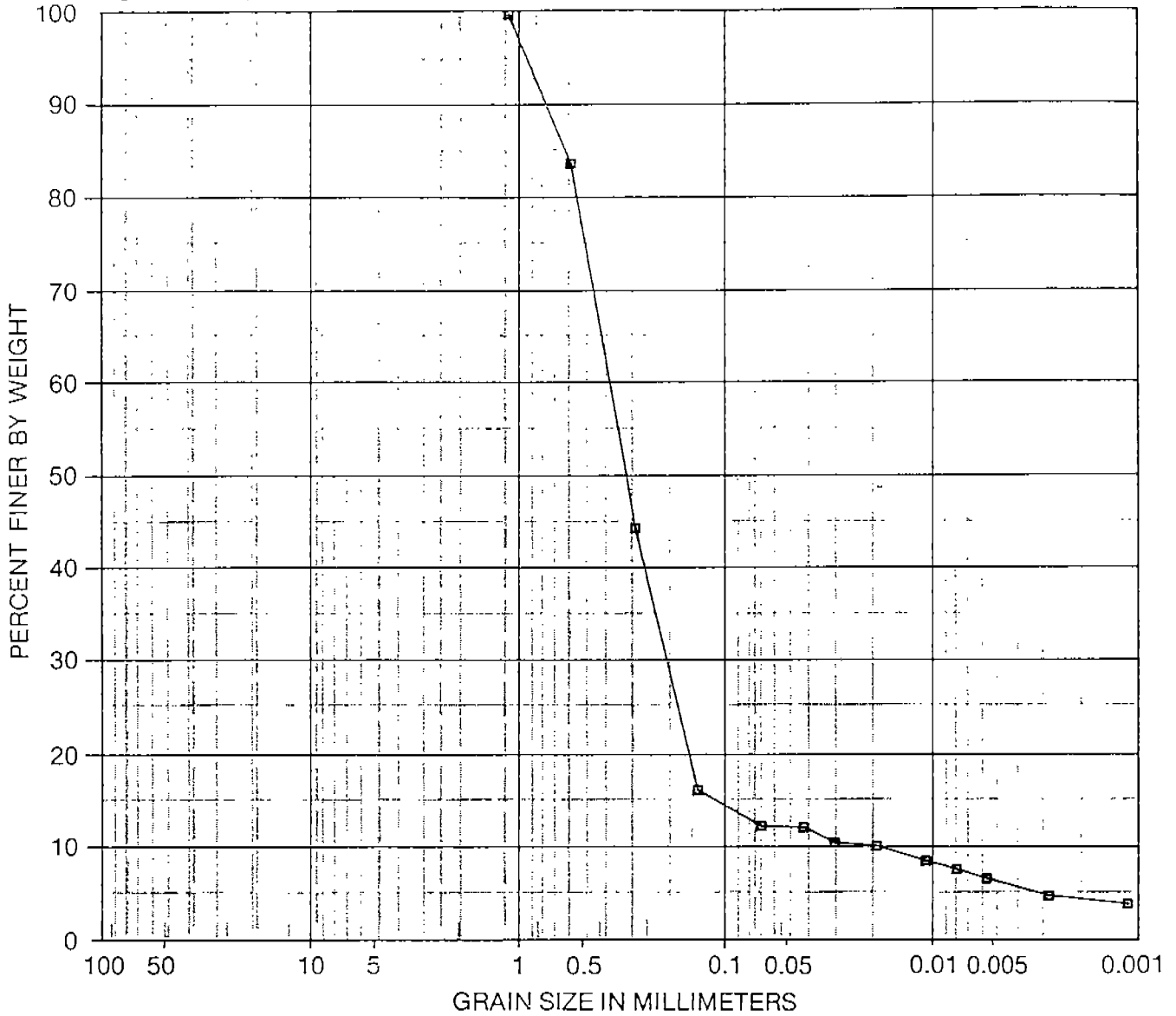

COBBLES	COARSE	FINE	COARSE	MEDIUM	FINE	SILT OR CLAY
	GRAVEL		SAND			

Symbol	Sample Source	Classification
□	OF-11-01 @ 5.0 FT	OLIVE-BROWN SILTY SAND (SM)



Harding Lawson Associates
Engineering and Environmental Services

Particle Size Analysis - Station 0F-11-01
Basewide Surface Water Outfall Investigation
Volume II - Basewide RI/FS
Fort Ord, California

PLATE

B13

DRAWN

JOB NUMBER
23366 041712

APPROVED

DATE

11-12-1993

REVISED

DATE

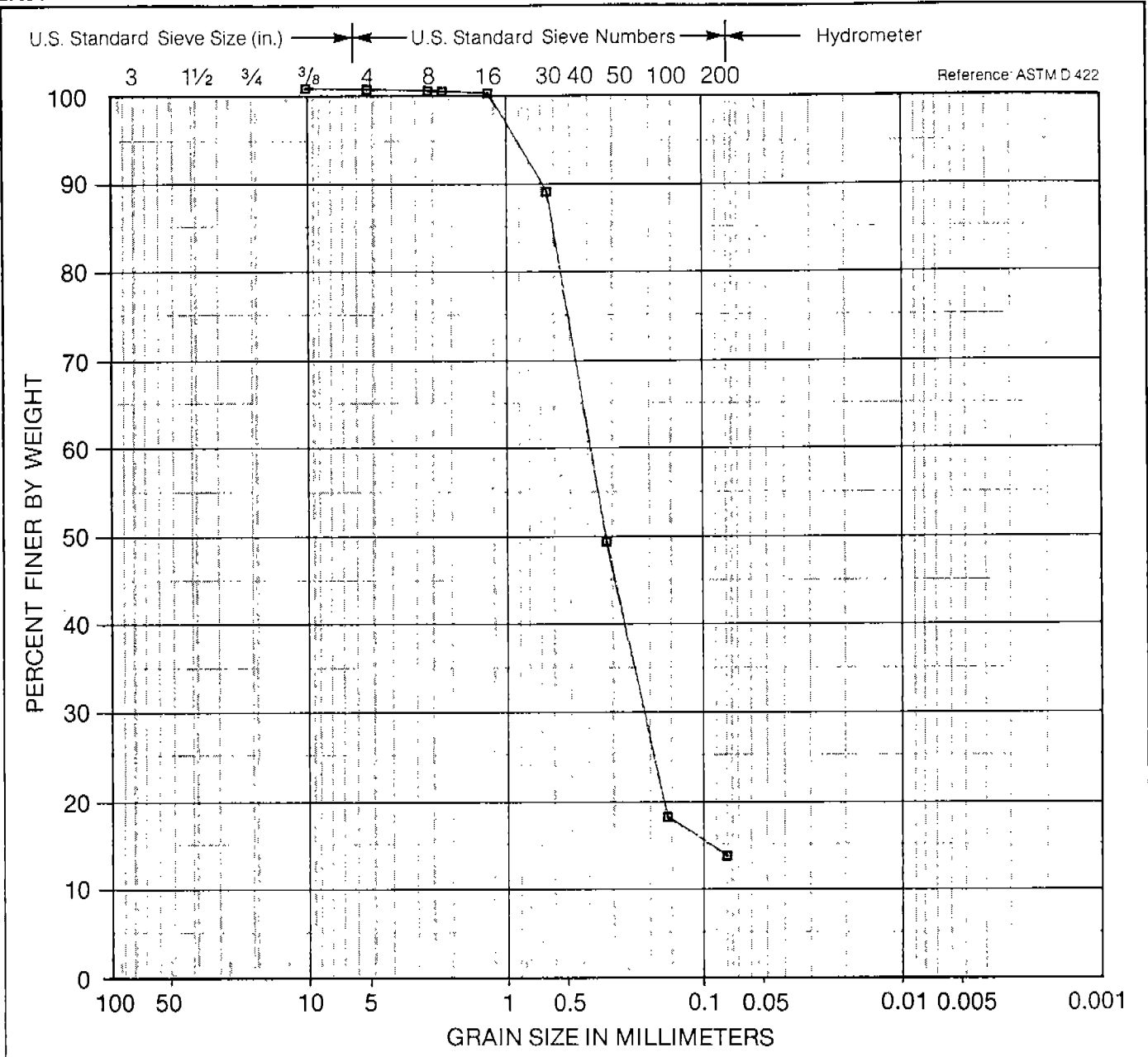

Reference: ASTM D 422

COBBLES	COARSE	FINE	COARSE	MEDIUM	FINE	SILT OR CLAY
	GRAVEL		SAND			

Symbol	Sample Source	Classification
□	BW-SG-11-2 @ 0.0 FT	DARK BROWN CLAYEY SAND (SC)



Harding Lawson Associates
 Engineers, Geologists
 & Geophysicists

Particle Size Analysis - Station OF-11-02
 Basewide Surface Water Outfall Investigation
 Remedial Investigation/ Feasibility Study
 Fort Ord, California

PLATE

B6

Site 16 & 17¹

¹ Please see Figure 5 for full citation.

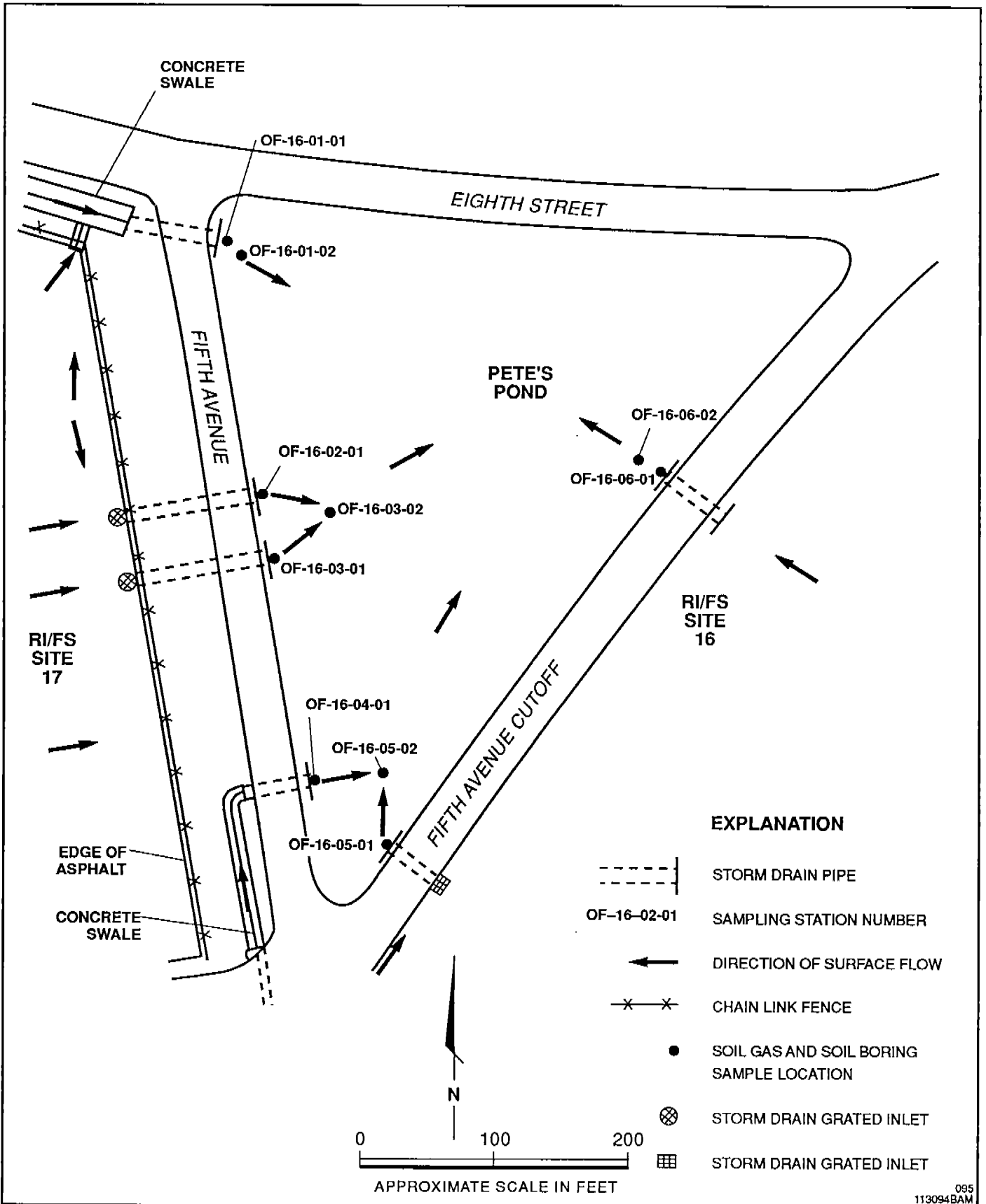

095
113094BAM



Harding Lawson Associates
Engineering and
Environmental Services

Detail of Pete's Pond-Sampling Location 16
Basewide Surface Water Outfall Investigation
Volume II - Remedial Investigation, Basewide RI/FS
Fort Ord, California

PLATE

12

DRAWN	JOB NUMBER	APPROVED	DATE	REVISED DATE
SPc	23366 041722	JDM	12/94	

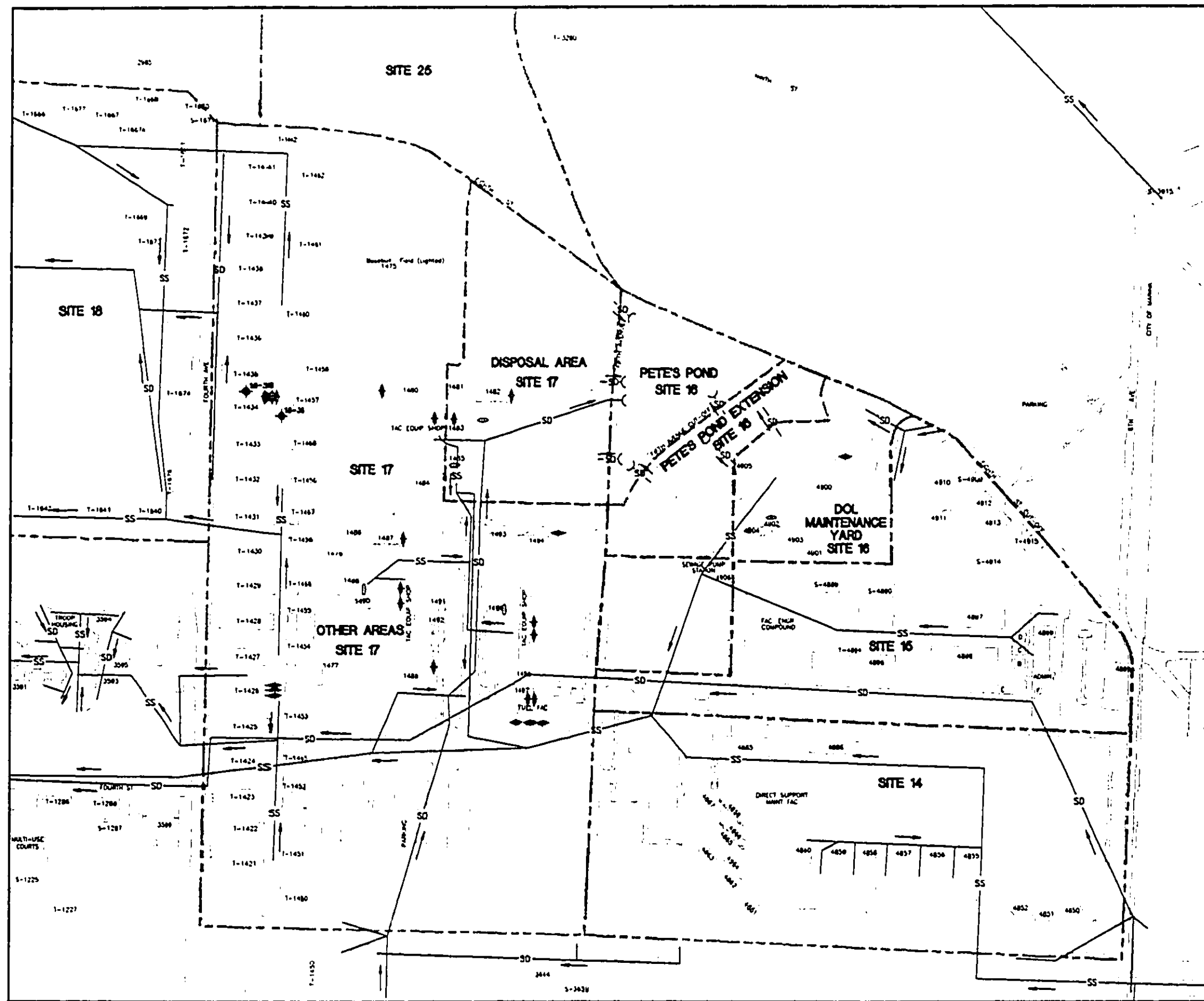

EXPLANATION

- ◆ SOIL BORING (BY OTHERS)
- ◆ EXISTING UNDERGROUND STORAGE TANK
- ◆ FORMER UNDERGROUND STORAGE TANK
- WASH RACK
- GREASE RACK
- OIL/WATER SEPARATOR
- SITE BOUNDARY
- AREA BOUNDARY
- ▭ BUILDING
- STORM DRAIN OUTFALL PIPE
- FENCE
- SD — STORM DRAIN LINE
- SS — SANITARY SEWER LINE

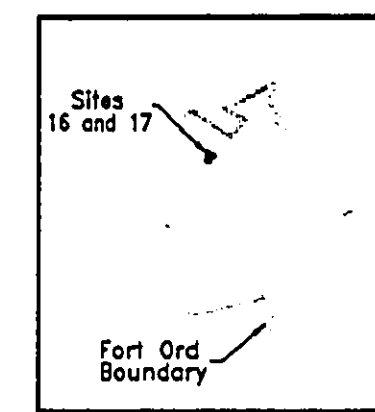

KEY MAP

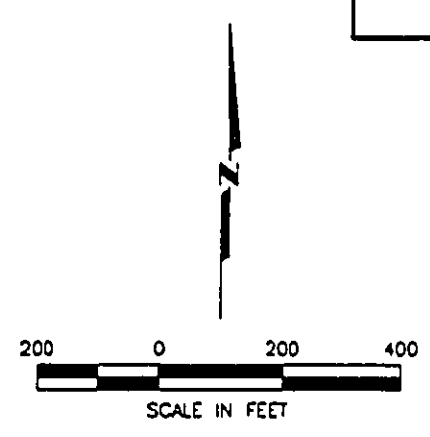

If this image is not as legible as this overlay, it's due to the poor quality of the original document

NO.	DATE	REVISIONS	HLA FILE NO.	PROJECT NO.	APPROVED	APPROVAL DATE	DRAWN BY	Harding Lawson Associates	Volume II - Remedial Investigation	Site Map	PLATE:
1	7/94	DRAFT	23366-099	23366-041711			PH	Engineering and Environmental Services	Basewide RI/FS	Sites 16 and 17	1
2	12/94	DRAFT FINAL	23366-099	23366-041721	RLA	11/23/94	PH		Fort Ord, California		

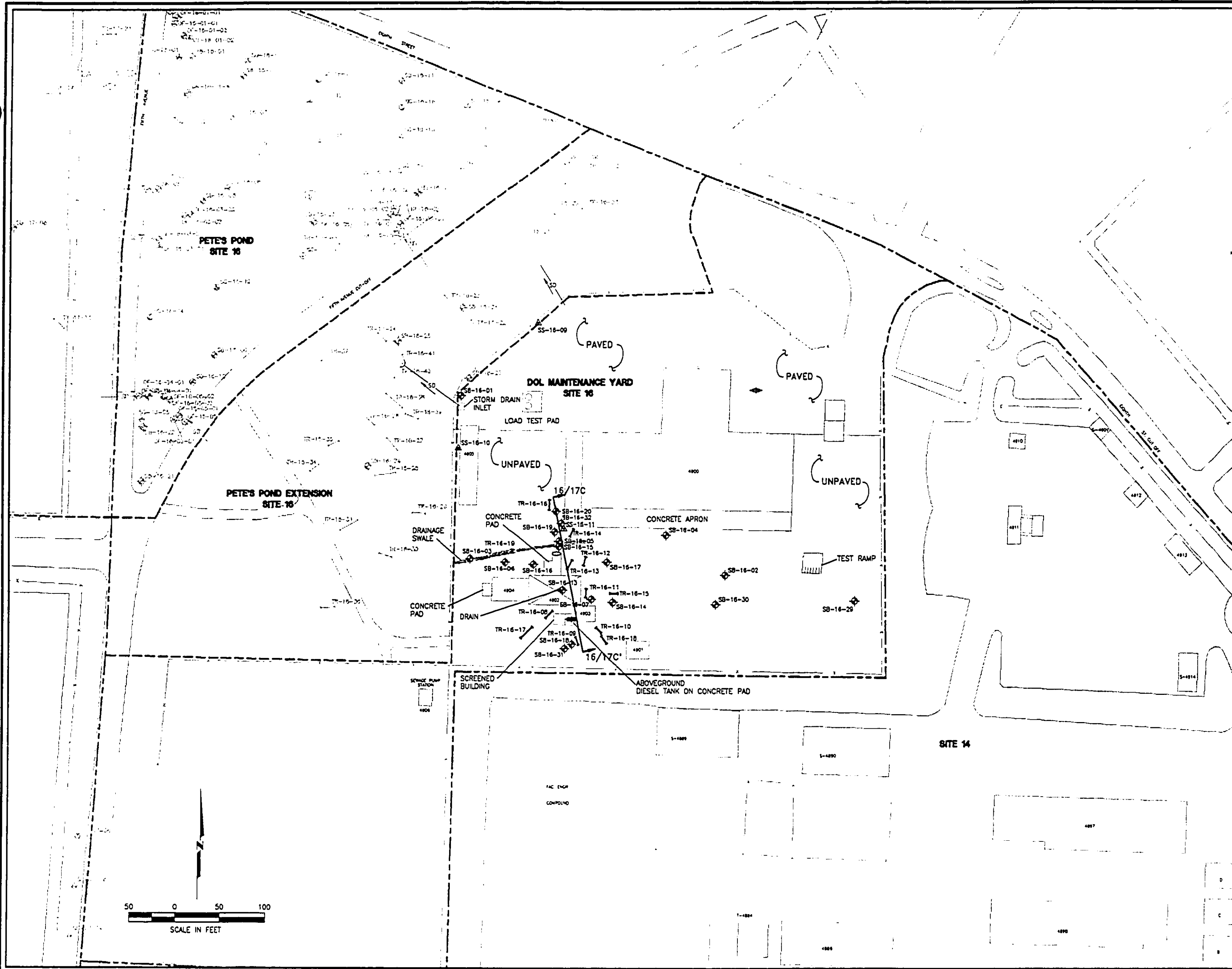

EXPLANATION

- TEST PIT
- SOIL GAS SAMPLING POINT (HLA)
- SURFACE SOIL SAMPLE (HLA)
- SOIL BORING/PILOT BORING (HLA)
- MONITORING WELL (HLA)
- SEDIMENT SAMPLE FROM STORM DRAIN OUTFALL PIPE
- CROSS-SECTION LINE
- EXISTING UNDERGROUND STORAGE TANK
- FORMER UNDERGROUND STORAGE TANK
- EXISTING ABOVEGROUND STORAGE TANK
- WASH RACK
- GREASE RACK
- OIL/WATER SEPARATOR
- SITE BOUNDARY
- AREA BOUNDARY
- BUILDING
- STORM DRAIN OUTFALL PIPE
- FENCE
- STORM DRAIN LINE

If this image is not as legible as this overlay, it's due to the poor quality of the original document

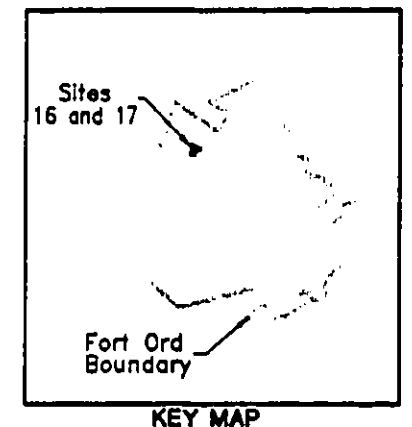

NO.	DATE	REVISIONS	HLA FILE NO.	PROJECT NO.	APPROVED	APPROVAL DATE	DRAWN BY	Harding Lawson Associates Engineering and Environmental Services	Volume II - Remedial Investigation Basewide RI/FS Fort Ord, California	Sample Location Map Site 16 - DOL Maintenance Yard	PLATE: 2
1	7/94	DRAFT	23366120	23366 041711			PH				
2	12/94	DRAFT FINAL	23366120	23366 041721	KFM	11/21/94	PH				

EXPLANATION

- TEST PIT
- SOIL GAS SAMPLING POINT (HLA)
- SURFACE SOIL SAMPLE (HLA)
- SOIL BORING/PILOT BORING (HLA)
- MONITORING WELL (HLA)
- SEDIMENT SAMPLE FROM STORM DRAIN OUTFALL PIPE
- CROSS-SECTION LINE
- EXISTING UNDERGROUND STORAGE TANK
- FORMER UNDERGROUND STORAGE TANK
- EXISTING ABOVEGROUND STORAGE TANK
- WASH RACK
- GREASE RACK
- OIL/WATER SEPARATOR
- SITE BOUNDARY
- AREA BOUNDARY
- BUILDING
- STORM DRAIN OUTFALL PIPE
- FENCE
- STORM DRAIN LINE
- GROUND SURFACE CONTOUR (FEET ABOVE MEAN SEA LEVEL, CONTOUR INTERVAL 1 FOOT)

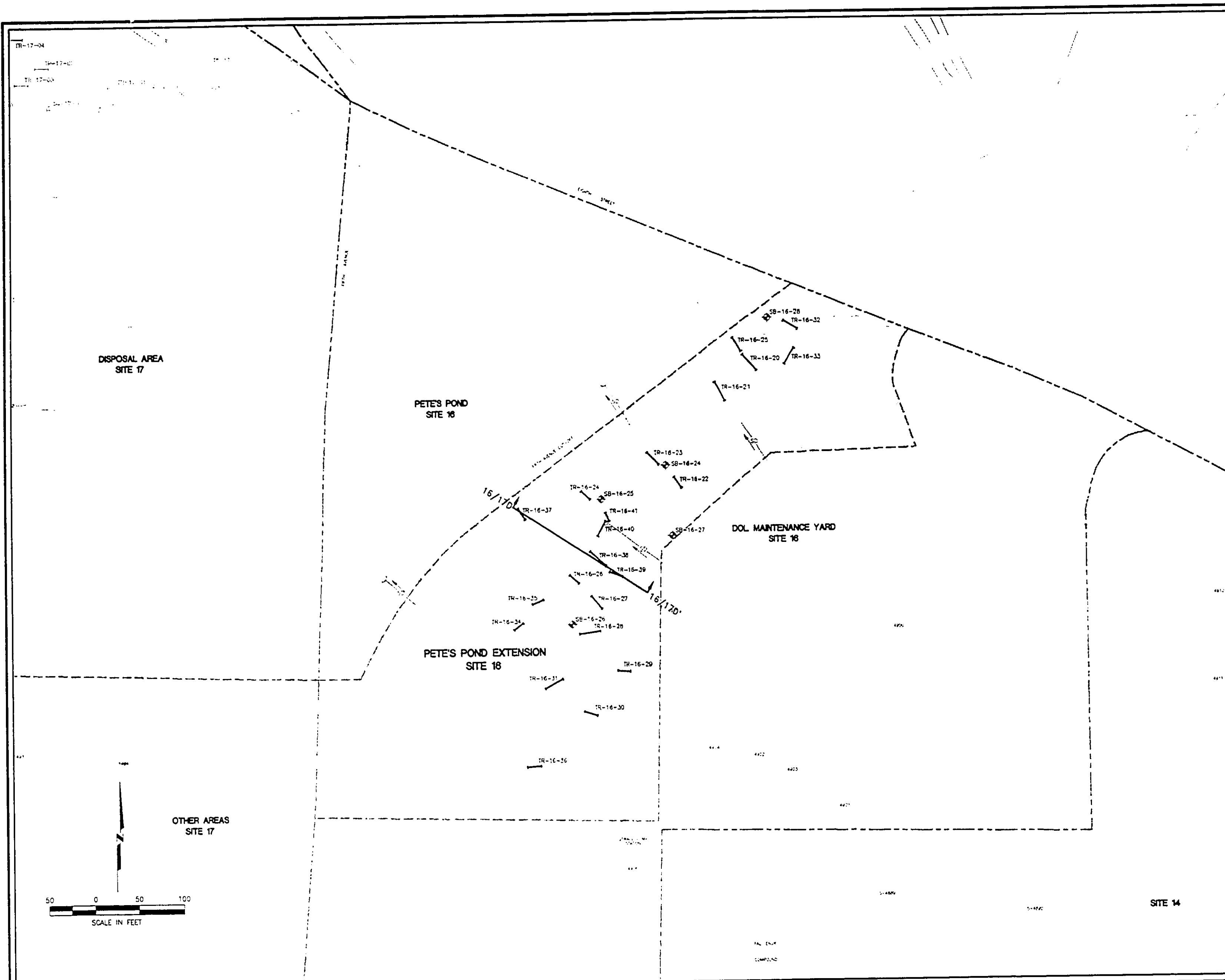

If this image is not as legible as this overlay, it's due to the poor quality of the original document

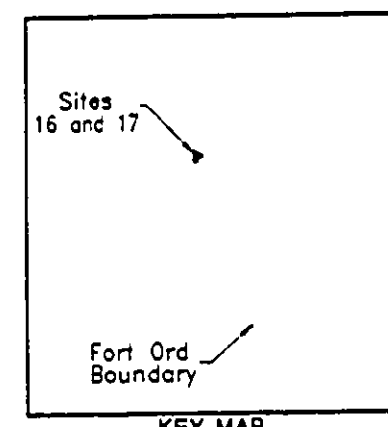

KEY MAP

NO.	DATE	REVISIONS	HLA FILE NO.	PROJECT NO.	APPROVED	APPROVAL DATE	DRAWN BY
1	7/94	DRAFT	23366121	23366 041711			PH
2	12/94	DRAFT FINAL	23366121	23366 041721	REB	11/24/94	PH

Harding Lawson Associates
Engineering and Environmental Services

Volume II - Remedial Investigation
Basewide RI/FS
Fort Ord, California

Sample Location Map
Site 16 - Pete's Pond Extension

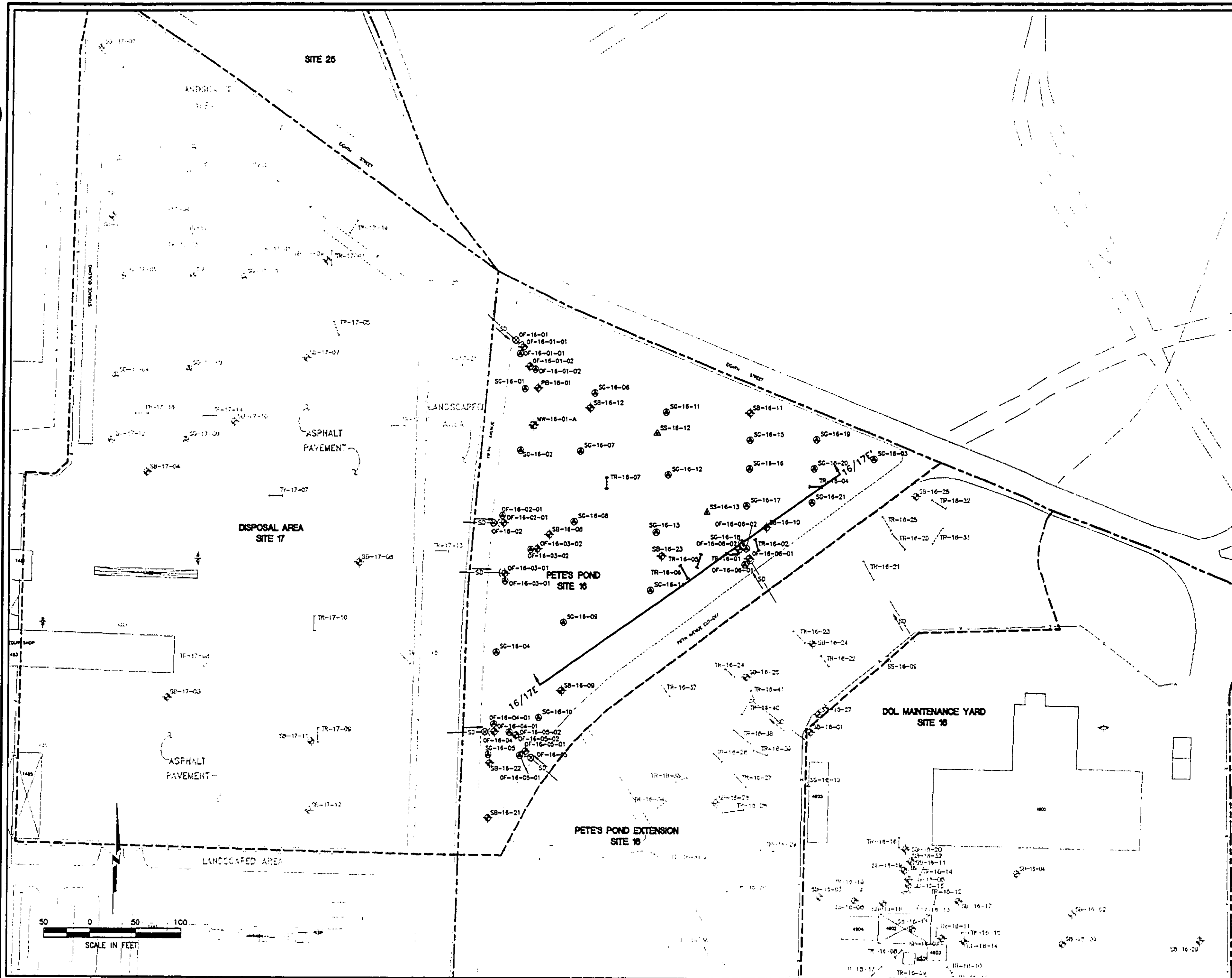

EXPLANATION

- ⊠ TEST PIT
- ⊙ SOIL GAS SAMPLING POINT (HLA)
- △ SURFACE SOIL SAMPLE (HLA)
- ⊕ SOIL BORING/PILOT BORING (HLA)
- ⊗ MONITORING WELL (HLA)
- ⊙ SEDIMENT SAMPLE FROM STORM DRAIN OUTFALL PIPE
- 16/17E 16/17E' CROSS-SECTION LINE
- ⬅ EXISTING UNDERGROUND STORAGE TANK
- ➡ FORMER UNDERGROUND STORAGE TANK
- ⬆ EXISTING ABOVEGROUND STORAGE TANK
- ⊠ WASH RACK
- ⊠ GREASE RACK
- OIL/WATER SEPARATOR
- SITE BOUNDARY
- - - AREA BOUNDARY
- ▭ BUILDING
- STORM DRAIN OUTFALL PIPE
- - - FENCE
- SD — STORM DRAIN LINE

If this image is not as legible as this overlay, it's due to the poor quality of the original document

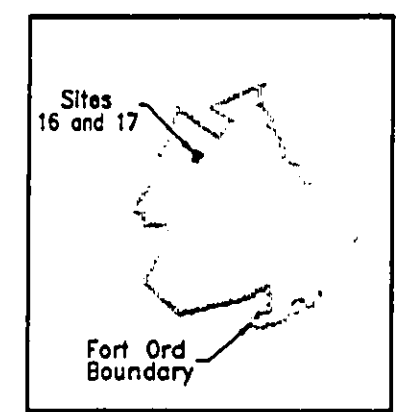

KEY MAP

NO.	DATE	REVISIONS	HLA FILE NO.	PROJECT NO.	APPROVED	APPROVAL DATE	DRAWN BY
1	7/94	DRAFT	23366122	23366 041711			PH
2	12/94	DRAFT FINAL	23366122	23366 041721	RF	11/14/94	PH

Harding Lawson Associates
Engineering and Environmental Services

Volume II - Remedial Investigation
Basewide RI/FS
Fort Ord, California

Sample Location Map
Site 16 - Pete's Pond

PLATE:

EXPLANATION

- I TEST PIT
- ⊙ SOIL GAS SAMPLING POINT (HLA)
- ⊕ SURFACE SOIL SAMPLE (HLA)
- ⊕ SOIL BORING/PILOT BORING (HLA)
- ⊕ MONITORING WELL (HLA)
- ⊕ SEDIMENT SAMPLE FROM STORM DRAIN OUTFALL PIPE
- 16/17F 16/17F CROSS-SECTION LINE
- ⬄ EXISTING UNDERGROUND STORAGE TANK
- ⬄ FORMER UNDERGROUND STORAGE TANK
- ⬄ EXISTING ABOVEGROUND STORAGE TANK
- ⊠ WASH RACK
- ⊠ GREASE RACK
- OIL/WATER SEPARATOR
- - - SITE BOUNDARY
- - - AREA BOUNDARY
- ▭ BUILDING
- STORM DRAIN OUTFALL PIPE
- FENCE
- SD — STORM DRAIN LINE

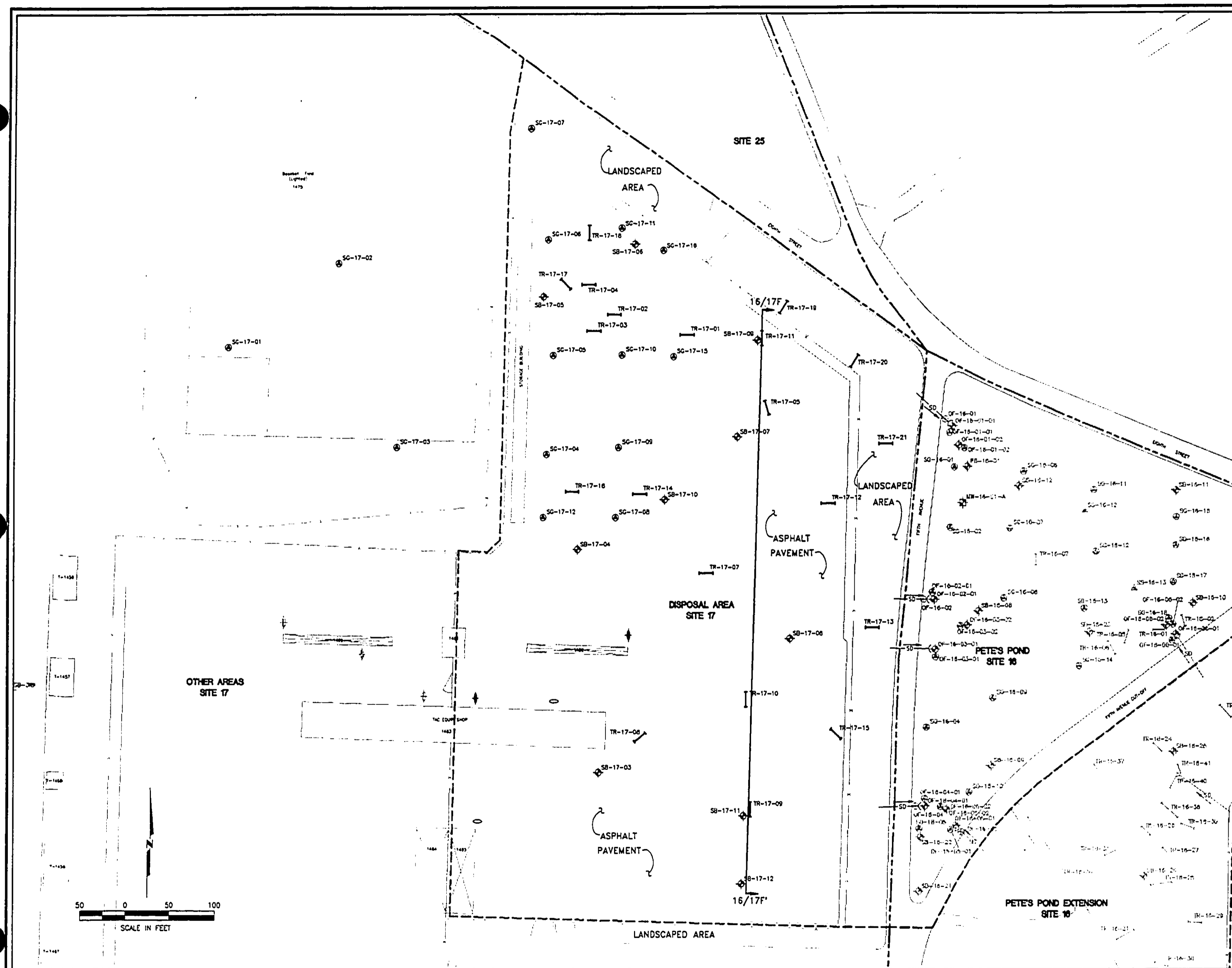

If this image is not as legible as this overlay, it's due to the poor quality of the original document

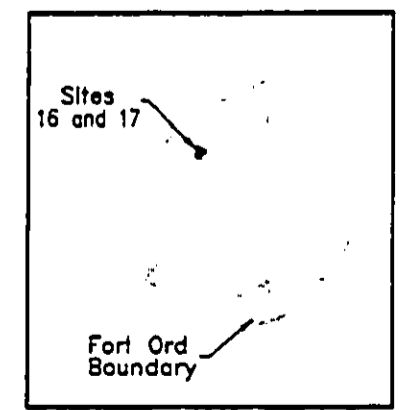

NO.	DATE	REVISIONS	HLA FILE NO.	PROJECT NO.	APPROVED	APPROVAL DATE	DRAWN BY
1	7/94	DRAFT	23366123	23366 041711			AED
2	12/94	DRAFT FINAL	23366123	23366 041721	RFA	11/21/94	AED

Harding Lawson Associates
Engineering and Environmental Services

Volume II - Remedial Investigation
Basewide RI/FS
Fort Ord, California

Sample Location Map
Site 17 - Disposal Area

PLATE: **5**

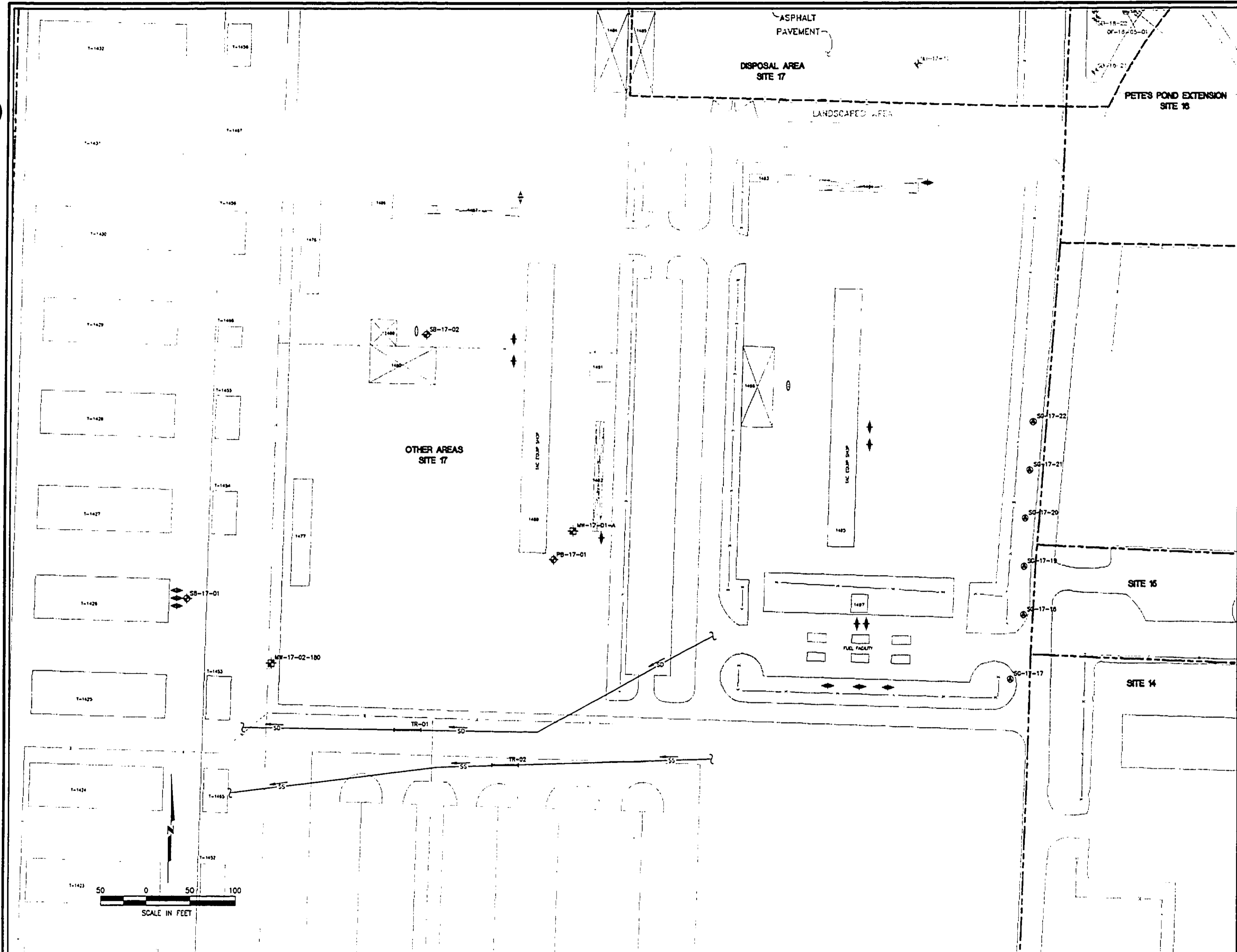

- EXPLANATION**
- TEST PIT
 - ⊙ SOIL GAS SAMPLING POINT (HLA)
 - ⊕ SOIL BORING/PILOT BORING (HLA)
 - ⊕ MONITORING WELL (HLA)
 - SEDIMENT SAMPLE FROM STORM DRAIN OUTFALL PIPE
 - ◊ EXISTING UNDERGROUND STORAGE TANK
 - ◊ FORMER UNDERGROUND STORAGE TANK
 - ◊ EXISTING ABOVEGROUND STORAGE TANK
 - WASH RACK
 - GREASE RACK
 - OIL/WATER SEPARATOR
 - SITE BOUNDARY
 - AREA BOUNDARY
 - BUILDING
 - STORM DRAIN OUTFALL PIPE
 - FENCE
 - SD — STORM DRAIN LINE
 - SS — SANITARY SEWER LINE

If this image is not as legible as this overlay, it's due to the poor quality of the original document

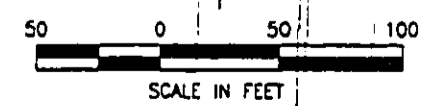
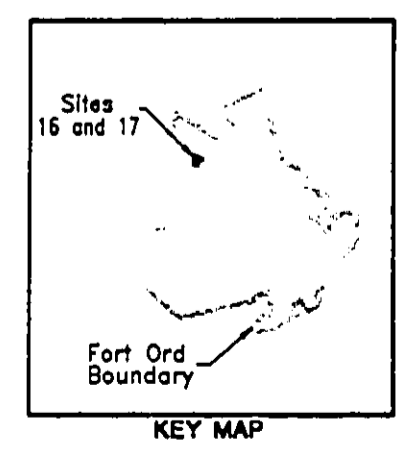

NO.	DATE	REVISIONS	HLA FILE NO.	PROJECT NO.	APPROVED	APPROVAL DATE	DRAWN BY
1	7/94	DRAFT	23366134	23366 041711			PH
2	12/94	DRAFT FINAL	23366134	23366 041721	RLA	11/21/94	PH

Harding Lawson Associates
Engineering and Environmental Services

Volume II - Remedial Investigation
Basewide RI/FS
Fort Ord, California

Sample Location Map
Site 17 - Other Areas

PLATE:
6

If this image is not as legible as this overlay, it's due to the poor quality of the original document

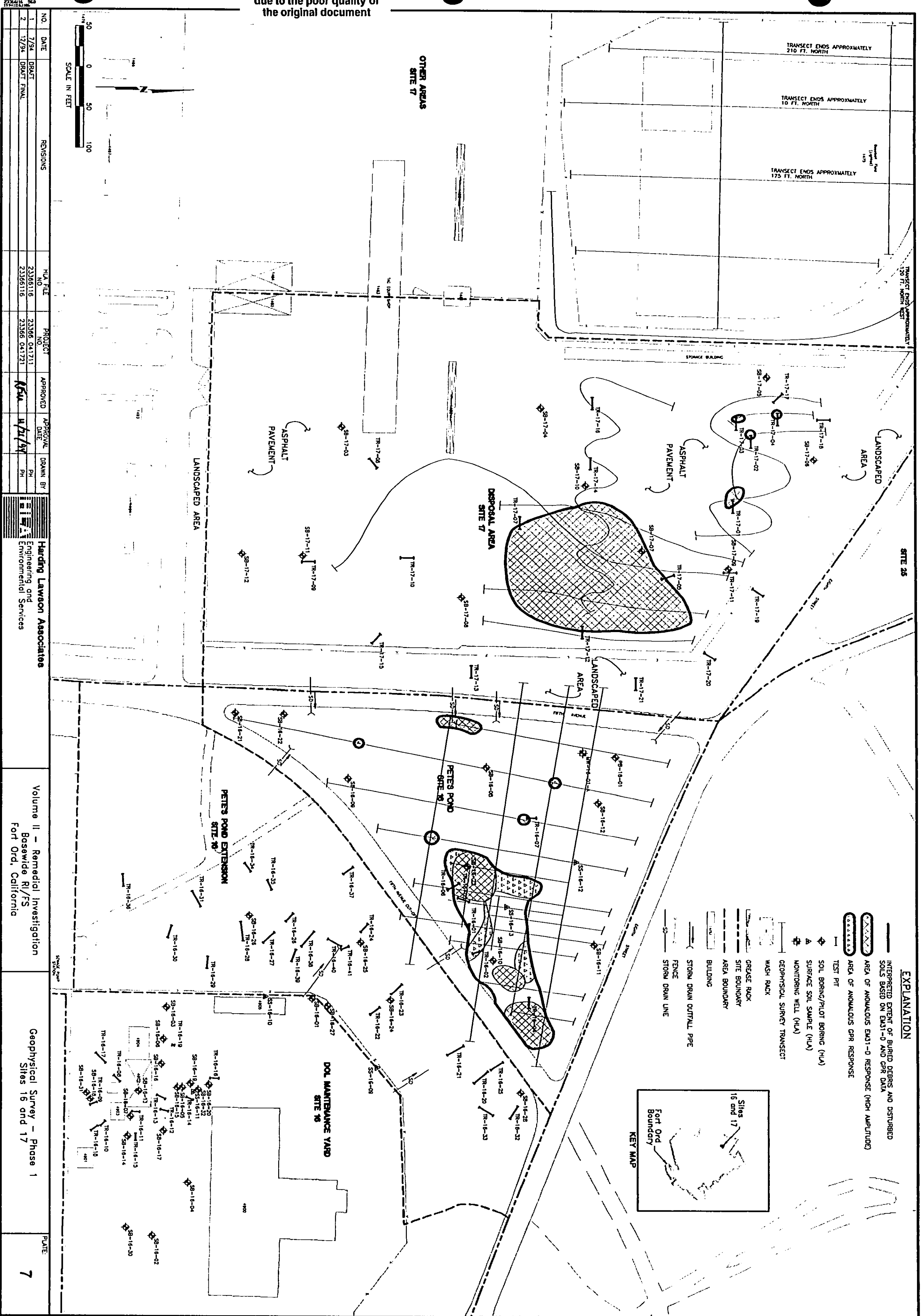

EXPLANATION

- INTERPRETED EXTENT OF BURIED DEBRIS AND DISTURBED SOILS BASED ON EM31-D AND CPR DATA
- ▭ AREA OF ANOMALOUS EM31-D RESPONSE (HIGH AMPLITUDE)
- AREA OF ANOMALOUS CPR RESPONSE
- TEST PIT
- ⊕ SOIL BORING/PILOT BORING (H/A)
- △ SURFACE SOIL SAMPLE (H/A)
- ⊕ MONITORING WELL (H/A)
- GEOPHYSICAL SURVEY TRANSECT
- WASH RACK
- GREASE RACK
- SITE BOUNDARY
- AREA BOUNDARY
- BUILDING
- STORM DRAIN OUTFALL PIPE
- FENCE
- STORM DRAIN LINE

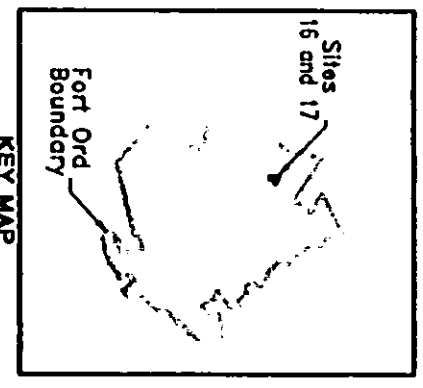

NO.	DATE	REVISIONS	PLT. FILE	PROJECT NO.	APPROVED	APPROVAL DATE	DRAWN BY
1	7/94	DRAFT	23386 041711		RSU		PH
2	12/96	DRAFT FINAL	23386 041721		RSU		PH

Harding Lawson Associates Engineering and Environmental Services	
Volume II - Remedial Investigation Basewide RI/FIS Fort Ord, California	Geophysical Survey - Phase 1 Sites 16 and 17
PLATE:	7

If this image is not as legible as this overlay, it's due to the poor quality of the original document

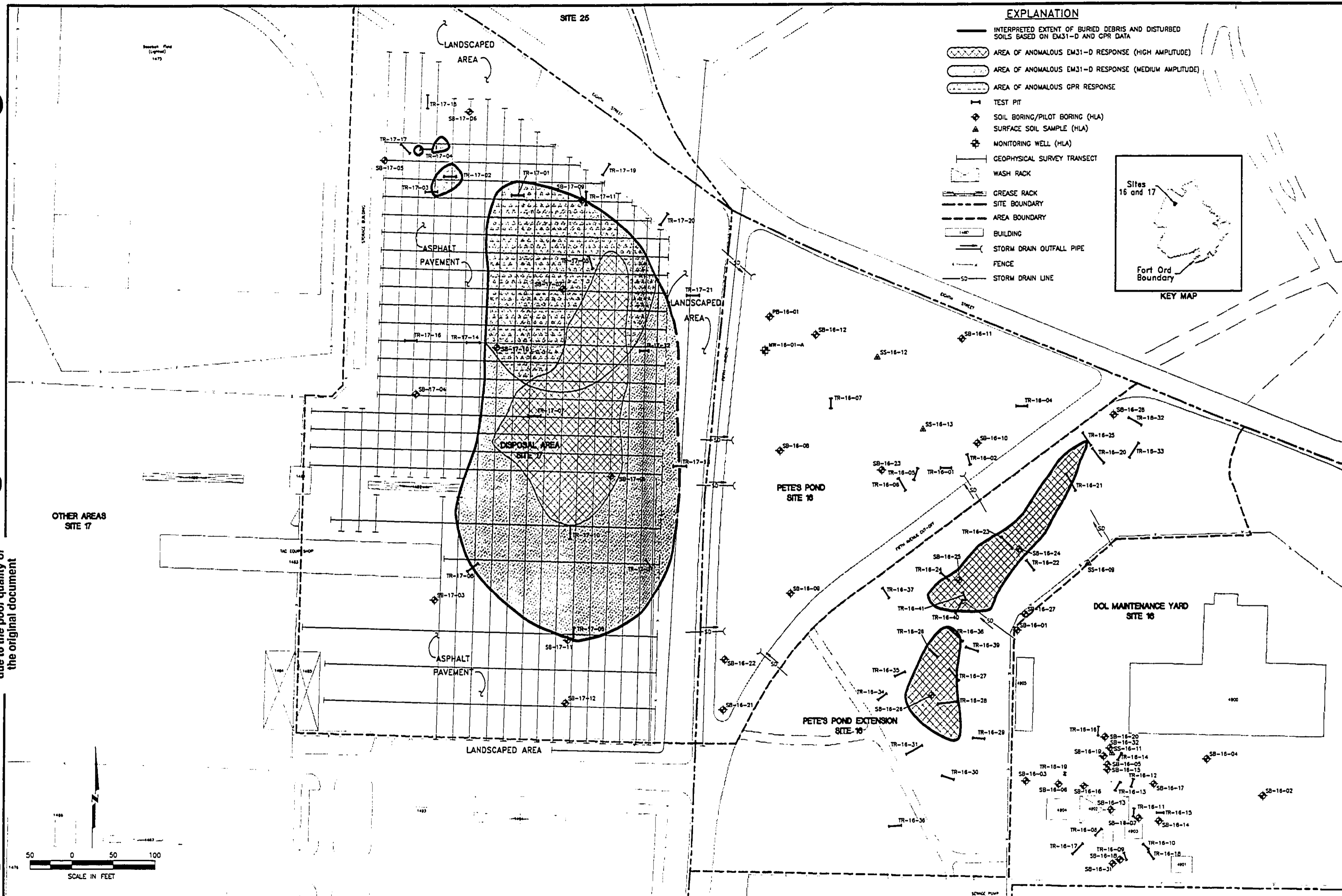

NO.	DATE	REVISIONS	HLA FILE NO.	PROJECT NO.	APPROVED	APPROVAL DATE	DRAWN BY
1	7/94	DRAFT	23366117	23366 041711			AED
2	12/94	DRAFT FINAL	23366117	23366 041721	RFM	11/21/94	AED

Harding Lawson Associates
 Engineering and Environmental Services

Volume II - Remedial Investigation
 Basewide RI/FS
 Fort Ord, California

Geophysical Survey - Phase 2
 Sites 16 and 17

PLATE:
8

EXPLANATION

- ⊥ TEST PIT
- ⊙ SOIL GAS SAMPLING POINT (HLA)
- △ SURFACE SOIL SAMPLE (HLA)
- ⊕ SOIL BORING/PILOT BORING (HLA)
- ⊕ MONITORING WELL (HLA)
- ⊕ EXISTING ABOVEGROUND STORAGE TANK
- ⊕ FORMER UNDERGROUND STORAGE TANK
- ⊕ WASH RACK
- GREASE RACK
- OIL/WATER SEPARATOR
- SITE BOUNDARY
- AREA BOUNDARY
- ▭ BUILDING
- STORM DRAIN OUTFALL PIPE
- FENCE
- SD --- STORM DRAIN LINE
- FULLY DEVELOPED/NOT SURVEYED
- ▨ UPLAND RUDERAL
- ▨ WET RUDERAL
- ▨ CENTRAL MARITIME CHAPARRAL
- ▨ LANDSCAPED

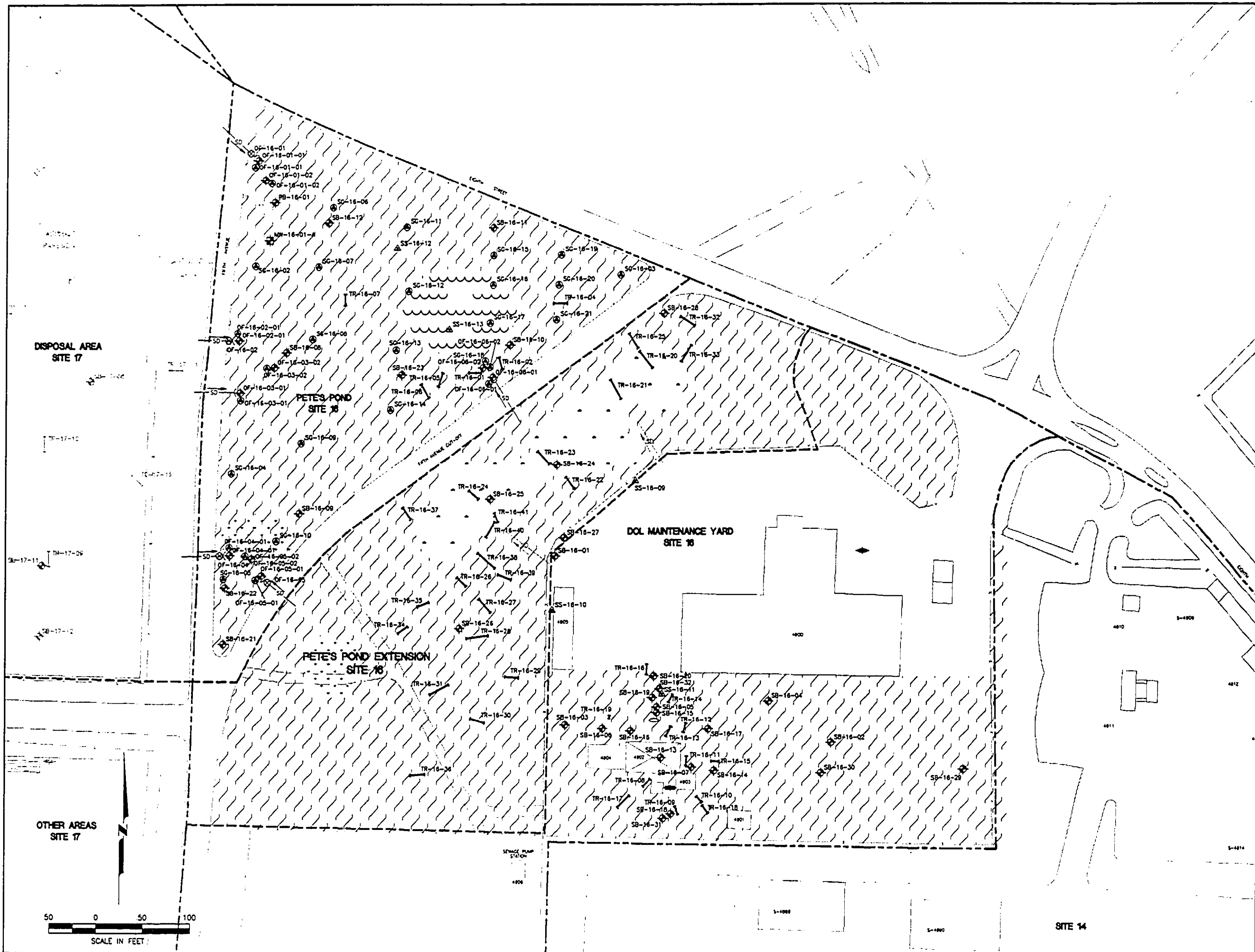

If this image is not as legible as this overlay, it's due to the poor quality of the original document

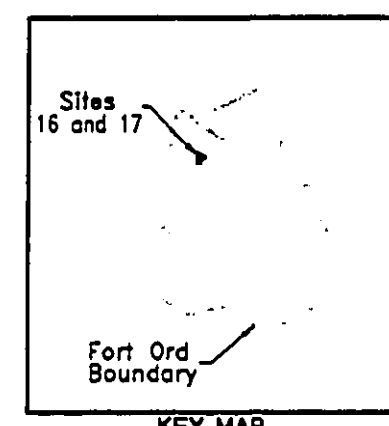

NO.	DATE	REVISIONS	HLA FILE NO.	PROJECT NO.	APPROVED	APPROVAL DATE	DRAWN BY	Harding Lawson Associates Engineering and Environmental Services	Volume II - Remedial Investigation Basewide RI/FS Fort Ord, California	Plant Community Map Site 16	PLATE: 9
1	7/94	DRAFT	23366388	23366 041711			AED				
2	12/94	DRAFT FINAL	23366388	23366 041721	[Signature]	11/24/94	AED				

EXPLANATION

- ⊥ TEST PIT
- ⊙ SOIL GAS SAMPLING POINT (HLA)
- ⊕ SOIL BORING/PILOT BORING (HLA)
- ⊕ MONITORING WELL (HLA)
- ◀ EXISTING UNDERGROUND STORAGE TANK
- ◀ FORMER UNDERGROUND STORAGE TANK
- WASH RACK
- GREASE RACK
- OIL/WATER SEPARATOR
- SITE BOUNDARY
- AREA BOUNDARY
- BUILDING
- STORM DRAIN OUTFALL PIPE
- FENCE
- SD— STORM DRAIN LINE
- FULLY DEVELOPED/NOT SURVEYED
- ▨ UPLAND RUDERAL
- ▨ LANDSCAPED
- ▨ COAST LIVE OAK WOODLAND

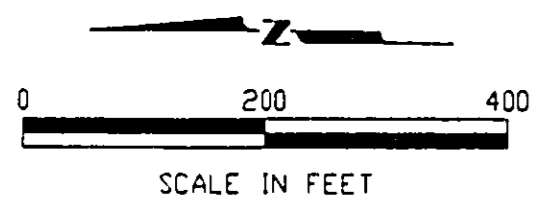
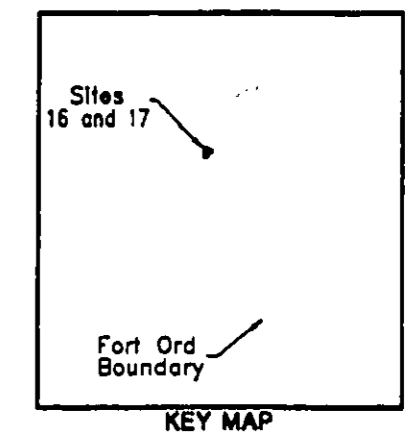
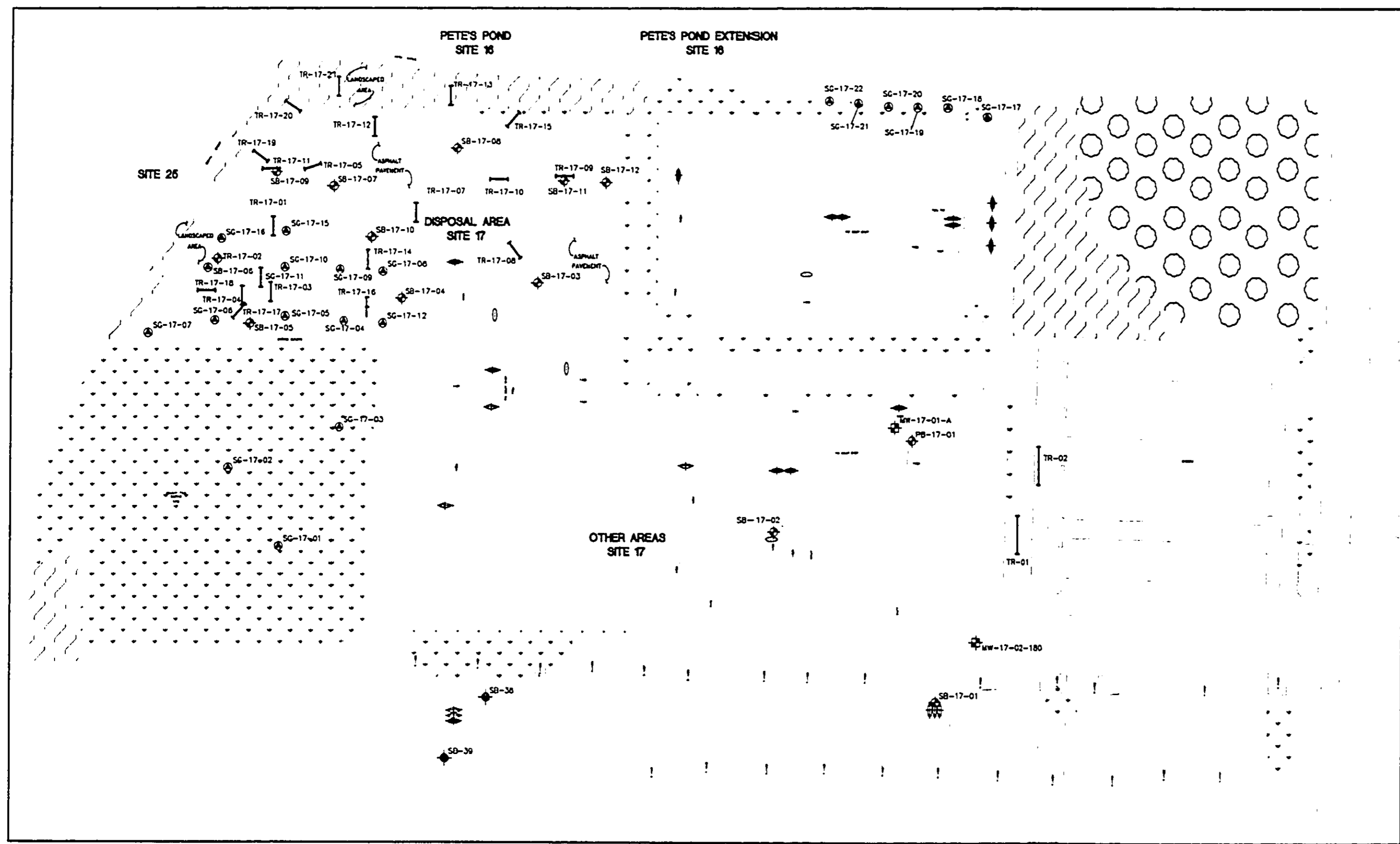

If this image is not as legible as this overlay, it's due to the poor quality of the original document

NO	DATE	REVISIONS	HLA FILE NO	PROJECT NO	APPROVED	APPROVAL DATE	DRAWN BY
1	7/94	DRAFT	23386389	23366 041711			AED
2	12/94	DRAFT FINAL	23386389	23366 041721	<i>(Signature)</i>	11/21/94	AED

Harding Lawson Associates

Engineering and Environmental Services

Volume II - Remedial Investigation
Basewide RI/FS
Fort Ord, California

Plant Community Map
Site 17

PLATE: **10**

EXPLANATION

- ⊕ MONITORING WELL (HLA)
- ⊕ MONITORING WELL (EA)
- 16/17A 16/17A' CROSS-SECTION LINE
- WASH RACK
- GREASE RACK
- SITE BOUNDARY
- AREA BOUNDARY
- APPROXIMATE WEST EDGE OF FORT ORD-SALINAS VALLEY AQUICLUDE (FO-SVA)
- ▭ BUILDING

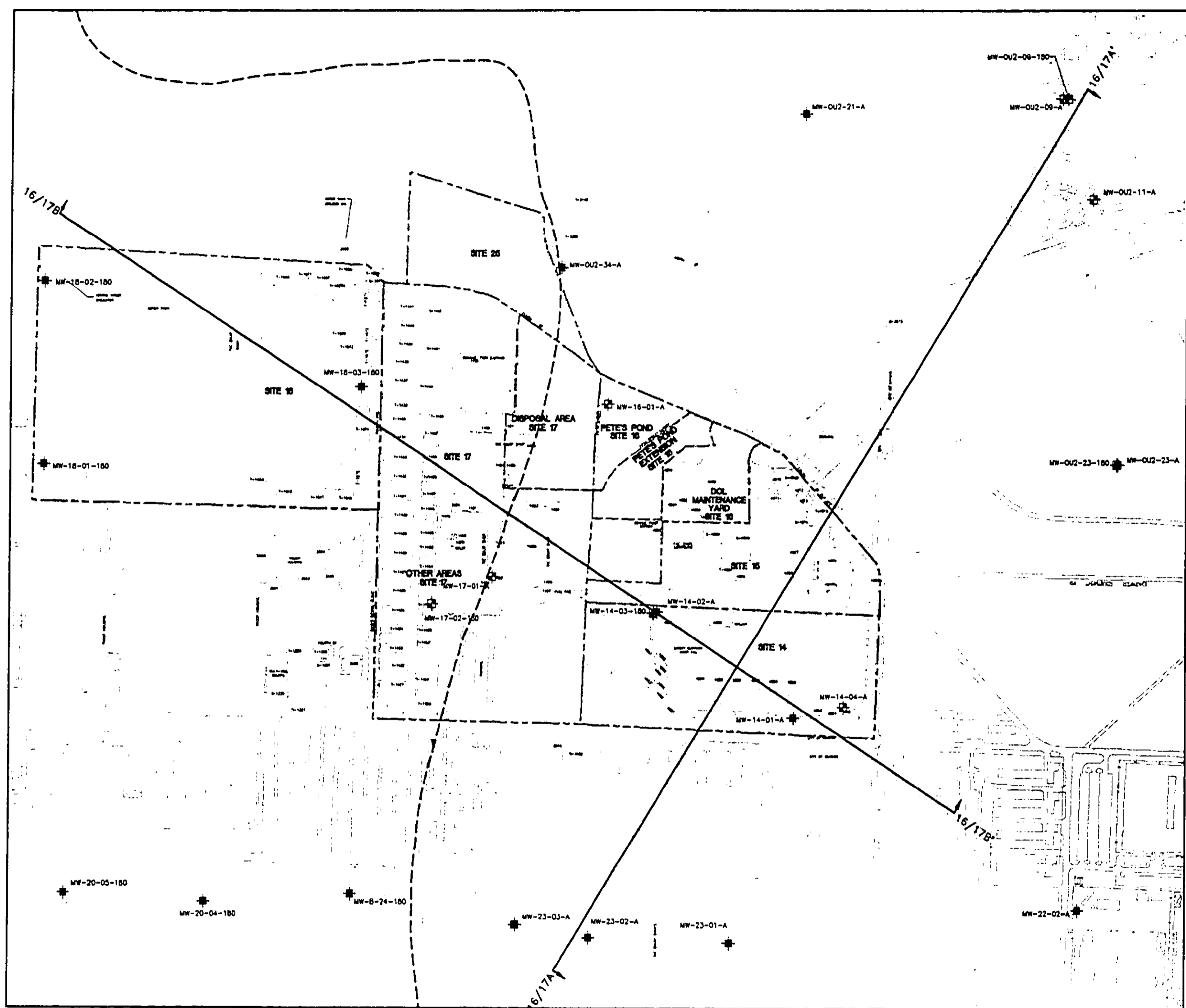



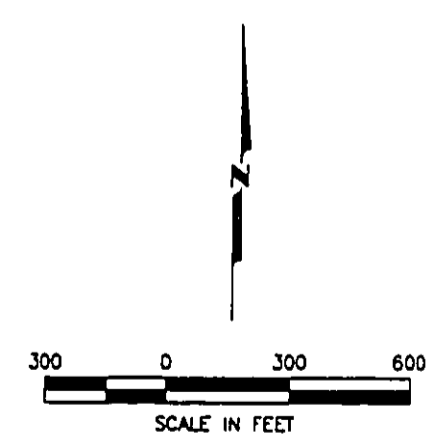
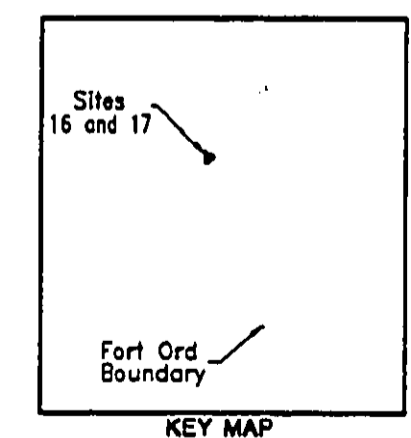



If this image is not as legible as this overlay, it's due to the poor quality of the original document

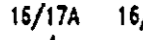
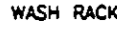
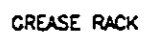
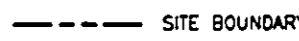
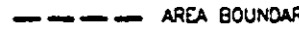
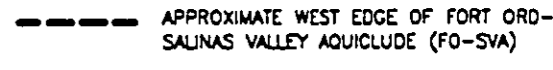

NO.	DATE	REVISIONS	HIA FILE NO	PROJECT NO.	APPROVED	APPROVAL DATE	DRAWN BY	Harding Lawson Associates	Volume II - Remedial Investigation Basewide RI/FS Fort Ord, California	Monitoring Well Location Map Sites 16 and 17	PLATE:
1	7/94	DRAFT	23366159	23366 041711			PH	Engineering and Environmental Services			11
2	12/94	DRAFT FINAL	23366159	23366 041721	RFM	11/23/99	PH				

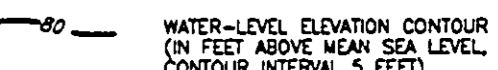
EXPLANATION

-  MONITORING WELL (HLA)
-  MONITORING WELL (EA)
-  CROSS-SECTION LINE
-  WASH RACK
-  GREASE RACK
-  SITE BOUNDARY
-  AREA BOUNDARY
-  APPROXIMATE WEST EDGE OF FORT ORD-SALINAS VALLEY AQUICLUDE (FO-SVA)
-  62.95 WATER-LEVEL ELEVATION (IN FEET MEAN SEA LEVEL)
-  NM NOT MEASURED
-  80 WATER-LEVEL ELEVATION CONTOUR (IN FEET ABOVE MEAN SEA LEVEL, CONTOUR INTERVAL 5 FEET)
-  BUILDING
-  FENCE

NOTE:
ALL WATER LEVELS WERE MEASURED ON FEBRUARY 16 AND 17, 1994

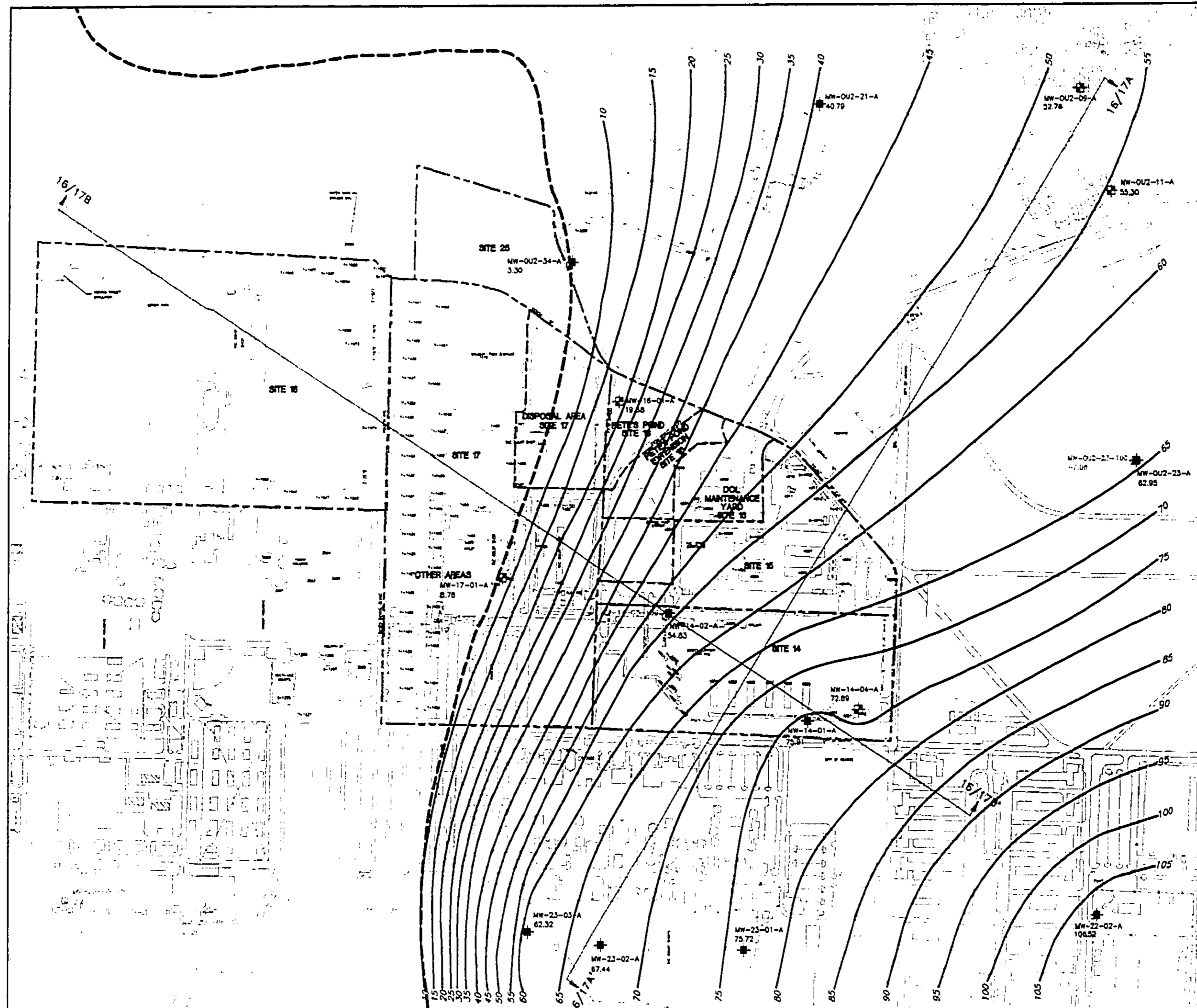



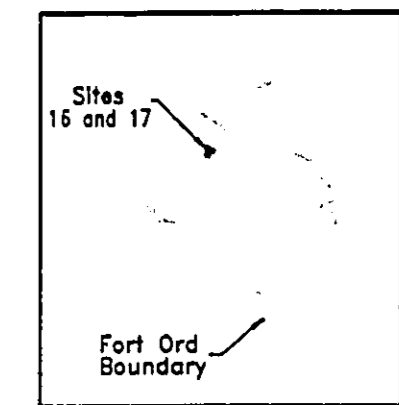







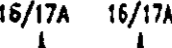
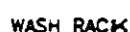

If this image is not as legible as this overlay, it's due to the poor quality of the original document

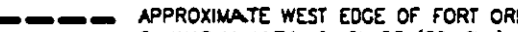

KEY MAP

NO.	DATE	REVISIONS	HLA FILE NO.	PROJECT NO.	APPROVED	APPROVAL DATE	DRAWN BY	Harding Lawson Associates Engineering and Environmental Services	Volume II - Remedial Investigation Basewide RI/FS Fort Ord, California	Water-Level Elevation Map A-Aquifer, February 1994 Sites 16 and 17	PLATE: 14
1	7/94	DRAFT	23366155	23366 041711			PH				
2	12/94	DRAFT FINAL	23366155	23366 041721	Rfm	11/22/94	PH				

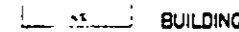
EXPLANATION

-  MONITORING WELL (HLA)
-  MONITORING WELL (EA)
-  CROSS-SECTION LINE
-  WASH RACK
-  GREASE RACK
-  SITE BOUNDARY
-  AREA BOUNDARY
-  APPROXIMATE WEST EDGE OF FORT ORD-SALINAS VALLEY AQUICLUDE (FO-SVA)
-  WATER-LEVEL ELEVATION (IN FEET MEAN SEA LEVEL)
-  NM NOT MEASURED
-  WATER-LEVEL ELEVATION CONTOUR (IN FEET MEAN SEA LEVEL, CONTOUR INTERVAL 1 FOOT)
-  BUILDING
-  FENCE

NOTE:
ALL WATER LEVELS WERE MEASURED ON FEBRUARY 16 AND 17, 1994

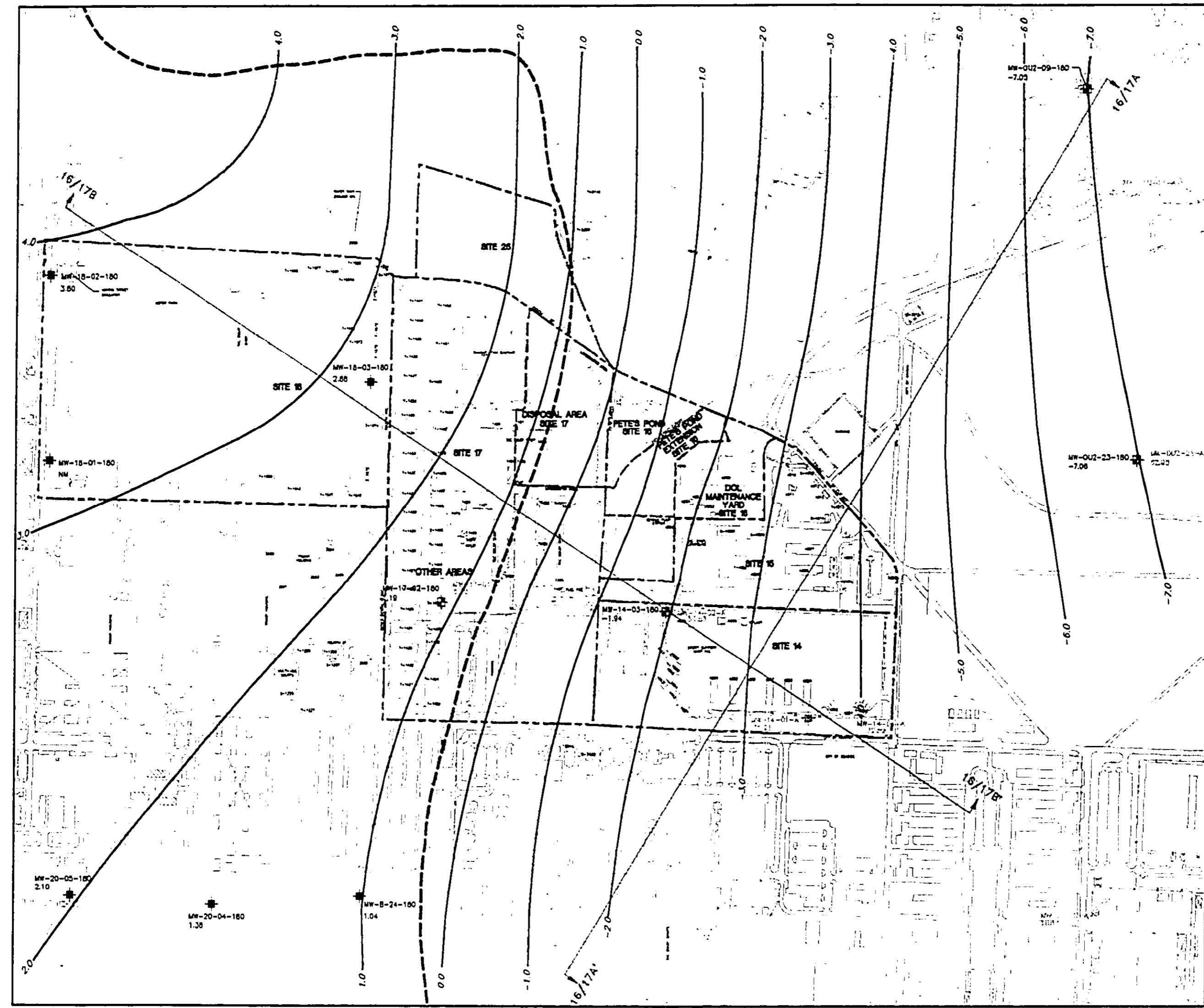

If this image is not as legible as this overlay, it's due to the poor quality of the original document

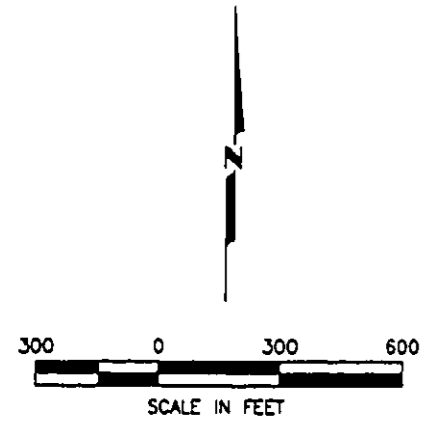
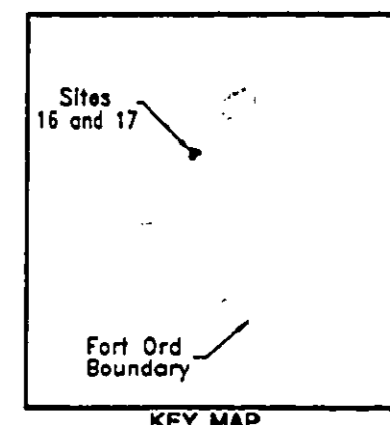

NO.	DATE	REVISIONS	HLA FILE NO.	PROJECT NO.	APPROVED	APPROVAL DATE	DRAWN BY	 Harding Lawson Associates Engineering and Environmental Services	Volume II - Remedial Investigation Basewide RI/FS Fort Ord, California	Water-Level Elevation Map Upper 180-Foot Aquifer, February 1994 Sites 16 and 17	PLATE:
1	7/94	DRAFT	23366144	23366 041711			PH				
2	12/94	DRAFT FINAL	23366144	23366 041721	<i>RSM</i>	11/24/94	PH				15

16/17C
NORTH

16/17C'
SOUTH

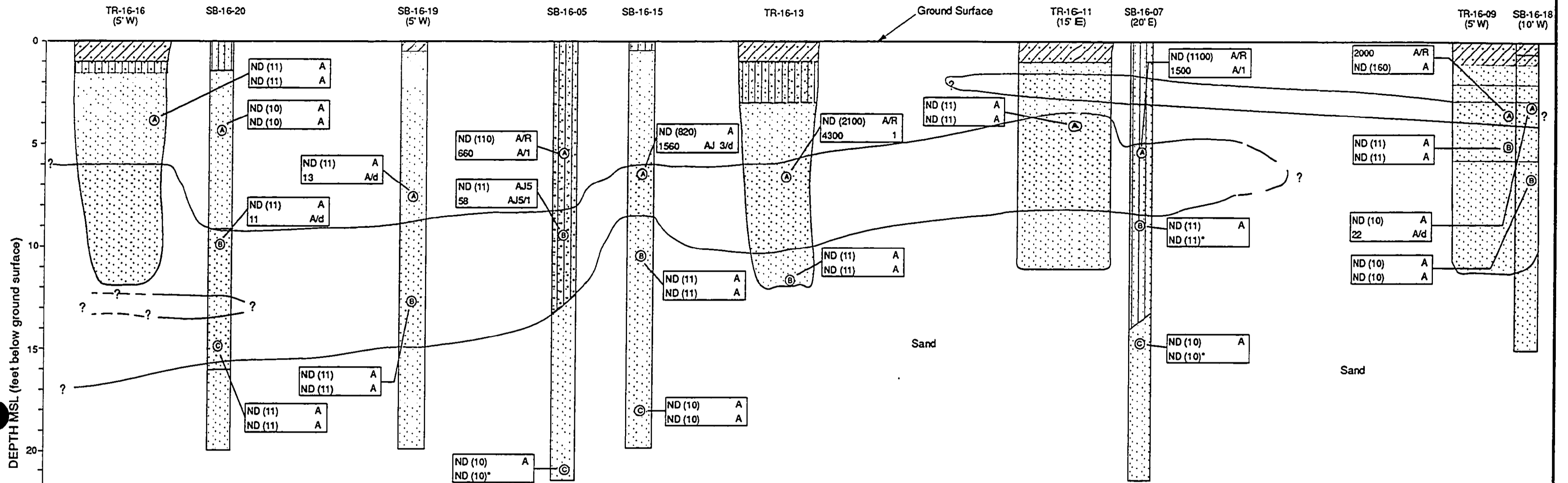

DEPTH MSL (feet below ground surface)

TR-16-16	SB-16-20	SB-16-19	SB-16-05	SB-16-15	TR-16-13	TR-16-11	SB-16-07	TR-16-09	SB-16-18
Ⓐ 9333B016027F	Ⓐ 93425016211F Ⓑ 93425016212F Ⓒ 93425016213F	Ⓐ 9342B016095F Ⓑ 9342B016096F	Ⓐ SB16055.5 Ⓑ SB16059.5 Ⓒ SB16052.5	Ⓐ 9342B016074F Ⓑ 9342B016075F Ⓒ 9342B016076F	Ⓐ 9333B016020F Ⓑ 9333B016021F	Ⓐ 9333B016013F	Ⓐ SB16075.5 Ⓑ SB16079.0 Ⓒ SB1615.5	Ⓐ 9333B016005F Ⓑ 9333B016011F	Ⓐ 9342B016088F Ⓑ 9342B016093F

Notes:

1. See Plate A1 in Appendix A for key to patterns
2. Location of cross section shown on Plate 2
3. The topography along the cross-section line is relatively flat at an approximate elevation of 165 feet MSL and has been shown as level. Elevations of soil borings and test pits were not surveyed.

Vertical Scale: 1" = 5'
Horizontal Scale: 1" = 10'
Vertical Exaggeration 2:1

EXPLANATION

- Extent of petroleum hydrocarbon-stained soil; dashed where inferred and queried where uncertain
- Type designation
SB - Soil Boring
TR - Test Pit
- Soil Boring or Test Pit number
- Site number
- (20' E) Distance and direction from cross-section line
- Concentrations in milligrams per kilogram
- TPH as diesel
- Unknown TPH as diesel
- Project and laboratory qualifiers; qualifiers are defined in Tables 41a and 41b.
- ND (11) Not detected at the reporting limit shown in parentheses.
- ND (10) * Unknown TPH as diesel was not specified as a target compound for Phase 1 sample analyses and when not detected was reported as NOT ANALYZED (NA). To be consistent with Phase 2 reporting standards, if unknown TPH as diesel was not detected, it is presented here as NOT DETECTED (ND) with the corresponding reporting limit for TPH as diesel.

NO.	DATE	REVISIONS	HLA FILE NO.	PROJECT NO.	APPROVED	APPROVAL DATE	DRAWN BY	Harding Lawson Associates Engineering and Environmental Services		Volume II - Remedial Investigation Basewide RVFS Fort Ord, California	Geologic Cross Section 16/17C - 16/17C' Site 16 - DOL Maintenance Yard	PLATE: 17
1	7/94	DRAFT	071494AG	23366 041711			AG					
2	12/94	DRAFT FINAL	mo112294LFD	23366 041721	AFM	11/31/97						

EXPLANATION

- TEST PIT
- SOIL GAS SAMPLING POINT (HLA)
- SURFACE SOIL SAMPLE (HLA)
- SOIL BORING/PILOT BORING (HLA)
- MONITORING WELL (HLA)
- SEDIMENT SAMPLE FROM STORM DRAIN OUTFALL PIPE
- EXISTING UNDERGROUND STORAGE TANK
- FORMER UNDERGROUND STORAGE TANK
- EXISTING ABOVEGROUND STORAGE TANK
- WASH RACK
- GREASE RACK
- OIL/WATER SEPARATOR
- SITE BOUNDARY
- AREA BOUNDARY
- BUILDING
- STORM DRAIN OUTFALL PIPE
- FENCE
- SD — STORM DRAIN LINE
- APPROXIMATE EXTENT OF SUBSURFACE INCINERATED AND UNINCINERATED DEBRIS IN SAND MATRIX; DEBRIS CONSISTS OF BROKEN, WHOLE, AND MELTED GLASS BOTTLES; METAL PIECES; ENGINE PARTS; BUCKETS AND CRATES; POSSIBLE MEDICAL MATERIAL; ORDNANCE; AND OTHER MISCELLANEOUS ITEMS.
- 2 — DEBRIS THICKNESS CONTOUR (CONTOUR INTERVAL 2 FEET)
- 1.0/5.0 DEPTH TO TOP OF DEBRIS (FEET) /DEPTH TO BOTTOM OF DEBRIS (FEET)

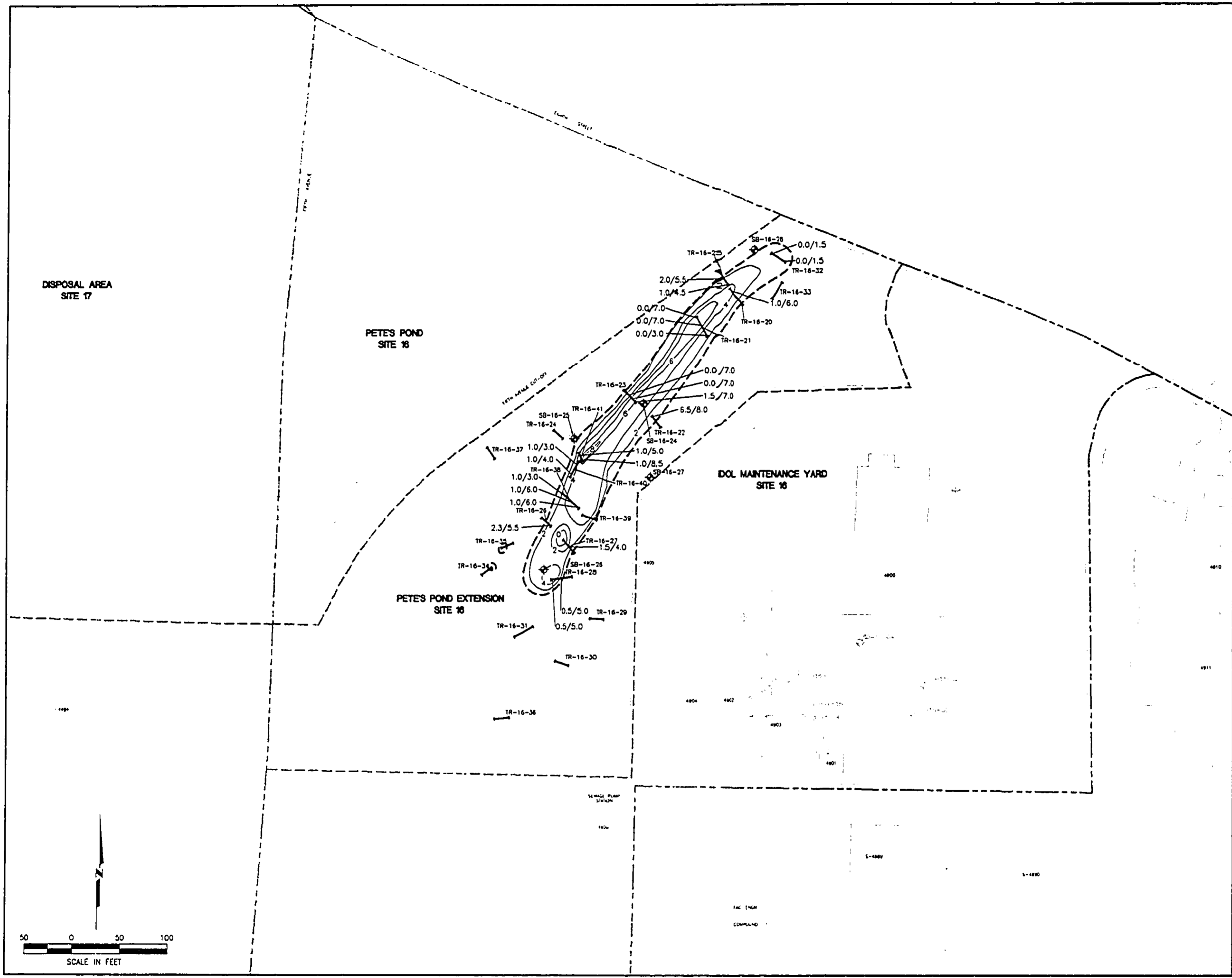

If this image is not as legible as this overlay, it's due to the poor quality of the original document

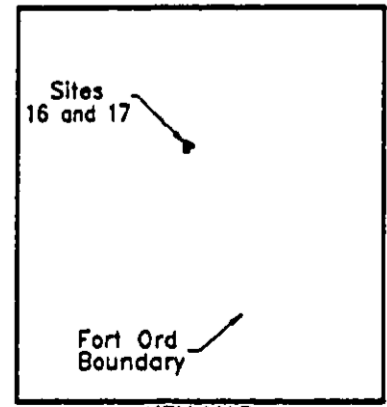

NO.	DATE	REVISIONS	HLA FILE NO.	PROJECT NO.	APPROVED	APPROVAL DATE	DRAWN BY
1	7/94	DRAFT	23366191	23366 041711			PH
2	12/94	DRAFT FINAL	23366191	23366 041721	RFM	11/21/94	PH

Harding Lawson Associates
Engineering and Environmental Services

Volume II - Remedial Investigation
Basewide RI/FS
Fort Ord, California

Debris Thickness Map
Site 16 - Pete's Pond Extension

PLATE: **19**

EXPLANATION

- ⊕ MONITORING WELL (HLA)
- ⊕ MONITORING WELL (EA)
- CROSS-SECTION LINE
- WASH RACK
- GREASE RACK
- FORMER HAZARDOUS WASTE STORAGE AREA
- SITE BOUNDARY
- AREA BOUNDARY
- BUILDING
- FENCE
- SAMPLE LOCATION
- SAMPLE COLLECTION DATE
- | | |
|----------|----------|
| SS-12-03 | 03/03/94 |
| PCE | 26.2 A |
| TCE | 16.3 NJ |
- PROJECT AND LABORATORY QUALIFIERS; QUALIFIERS ARE DEFINED IN TABLES 41a AND 41b.
- CONCENTRATIONS IN MICROGRAMS PER LITER
- ANALYTES-- ABBREVIATIONS ARE DEFINED IN THE LIST OF ACRONYMS AND ABBREVIATIONS. SEE NOTES.
- ND(1.0) NOT DETECTED AT THE REPORTING LIMIT SHOWN IN PARENTHESES
- NA NOT ANALYZED
- APPROXIMATE WESTERN EDGE OF FORT ORD-SALINAS VALLEY AQUICLUDE (FO-SVA).
- TOTAL VOC CONCENTRATION CONTOUR IN MICROGRAMS PER LITER, FEBRUARY-MARCH 1994 SAMPLING ROUND.

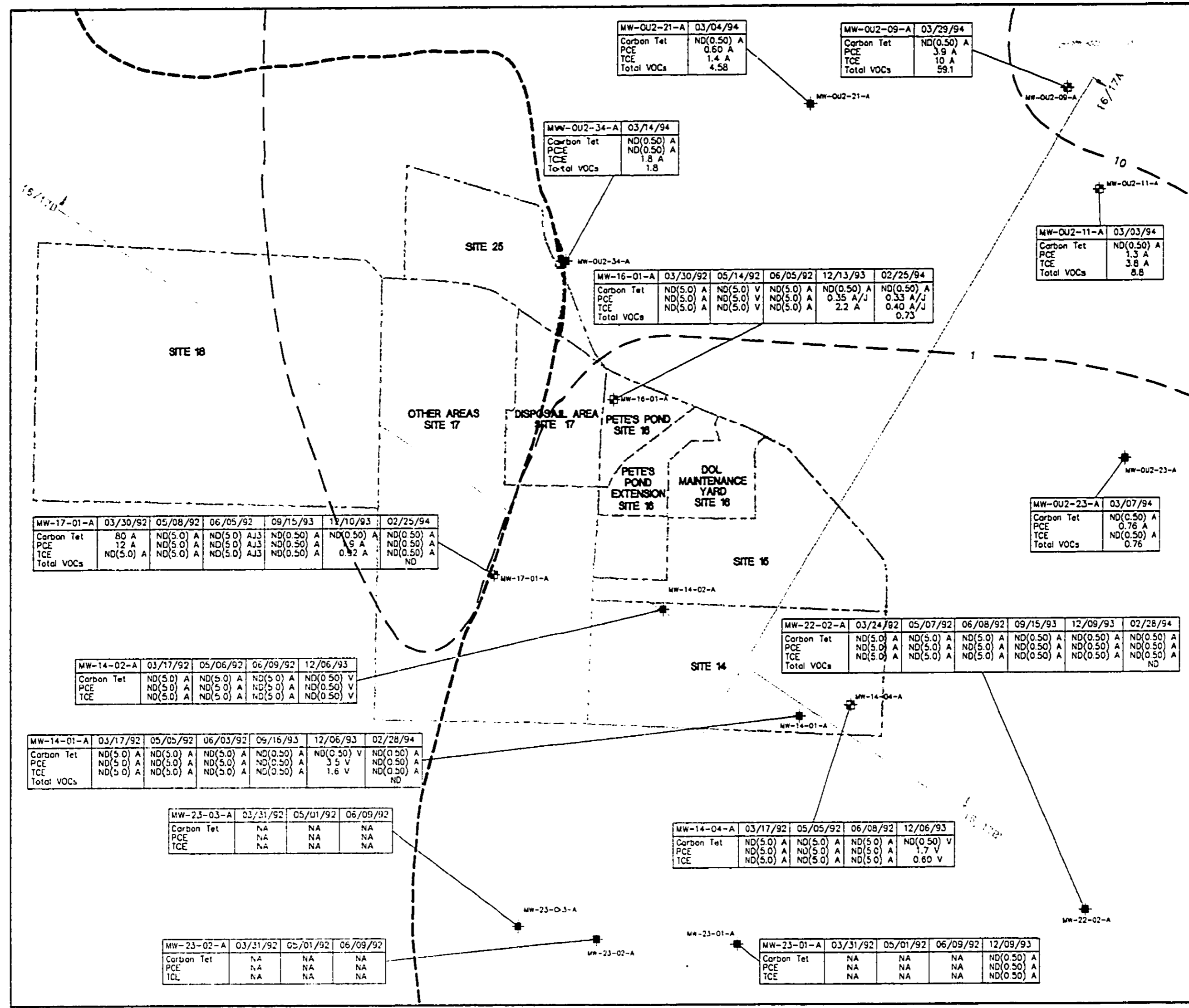

- NOTES:**
1. CONTOURS REPRESENT CONCENTRATIONS OF TOTAL VOCs DETECTED USING EPA METHODS 8010/8020 IN BOTH THE A-AQUIFER AND THE UPPER 180-FOOT AQUIFER AS MODIFIED FROM PLATE D6, VOLUME II - RI, BASEWIDE HYDROGEOLOGIC CHARACTERIZATION SECTION.
 2. THE AQUIFER DOES NOT EXIST WEST OF THE SVA, AND CONTOURS EXTENDING THROUGH THIS AREA REPRESENT CONCENTRATIONS OF TOTAL VOC'S IN THE UPPER 180-FOOT AQUIFER.
 3. THE CHEMICAL CONCENTRATION CONTOURS ARE BASED ON ONE INTERPRETATION OF THE DATA AVAILABLE WHEN THIS REPORT WAS PREPARED; OTHER INTERPRETATIONS MAY BE POSSIBLE.

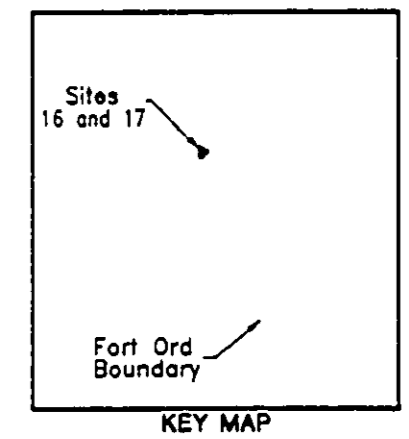
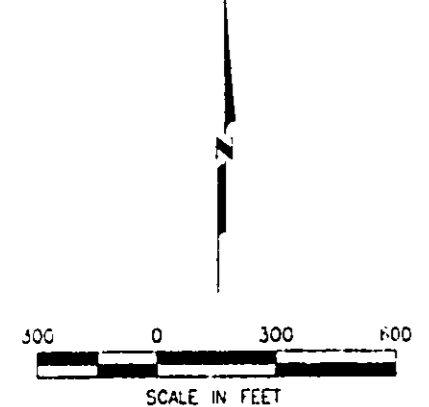

If this image is not as legible as this overlay, it's due to the poor quality of the original document

NO	DATE	REVISIONS	HLA FILE NO	PROJECT NO	APPROVED	APPROVAL DATE	DRAWN BY	Harding Lawson Associates Engineering and Environmental Services	Volume II - Remedial Investigation Basewide RI/FS Fort Ord, California	Distribution of Selected VOCs and Total VOCs Detected in Groundwater of A-Aquifer Sites 16 and 17	PLATE: 32
1	7/94	DRAFT	23366189	23366 041711	REM	07/21/94	PH				
2	12/94	DRAFT FINAL	23366189	23366 041721	REM		PH				

EXPLANATION

- TEST PIT
- SOIL GAS SAMPLING POINT (HLA)
- SURFACE SOIL SAMPLE (HLA)
- ⊕ SOIL BORING/PILOT BORING (HLA)
- MONITORING WELL (HLA)
- ◀ EXISTING UNDERGROUND STORAGE TANK
- ◀ FORMER UNDERGROUND STORAGE TANK
- WASH RACK
- GREASE RACK
- OIL/WATER SEPARATOR
- SITE BOUNDARY
- AREA BOUNDARY
- BUILDING
- STORM DRAIN OUTFALL PIPE
- FENCE
- - - - - APPROXIMATE EXTENT OF SUBSURFACE DEBRIS, DASHED WHERE INFERRED AND QUERIED WHERE UNCERTAIN.
- DEBRIS THICKNESS CONTOUR (CONTOUR INTERVAL 2 FEET)
- 2.0/6.0 DEPTH TO TOP OF DEBRIS /DEPTH TO BOTTOM OF DEBRIS (FEET)
- NP SUBSURFACE DEBRIS NOT PRESENT

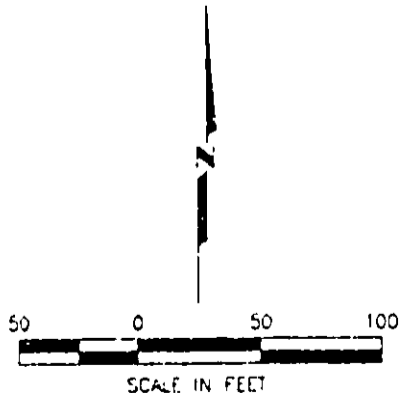
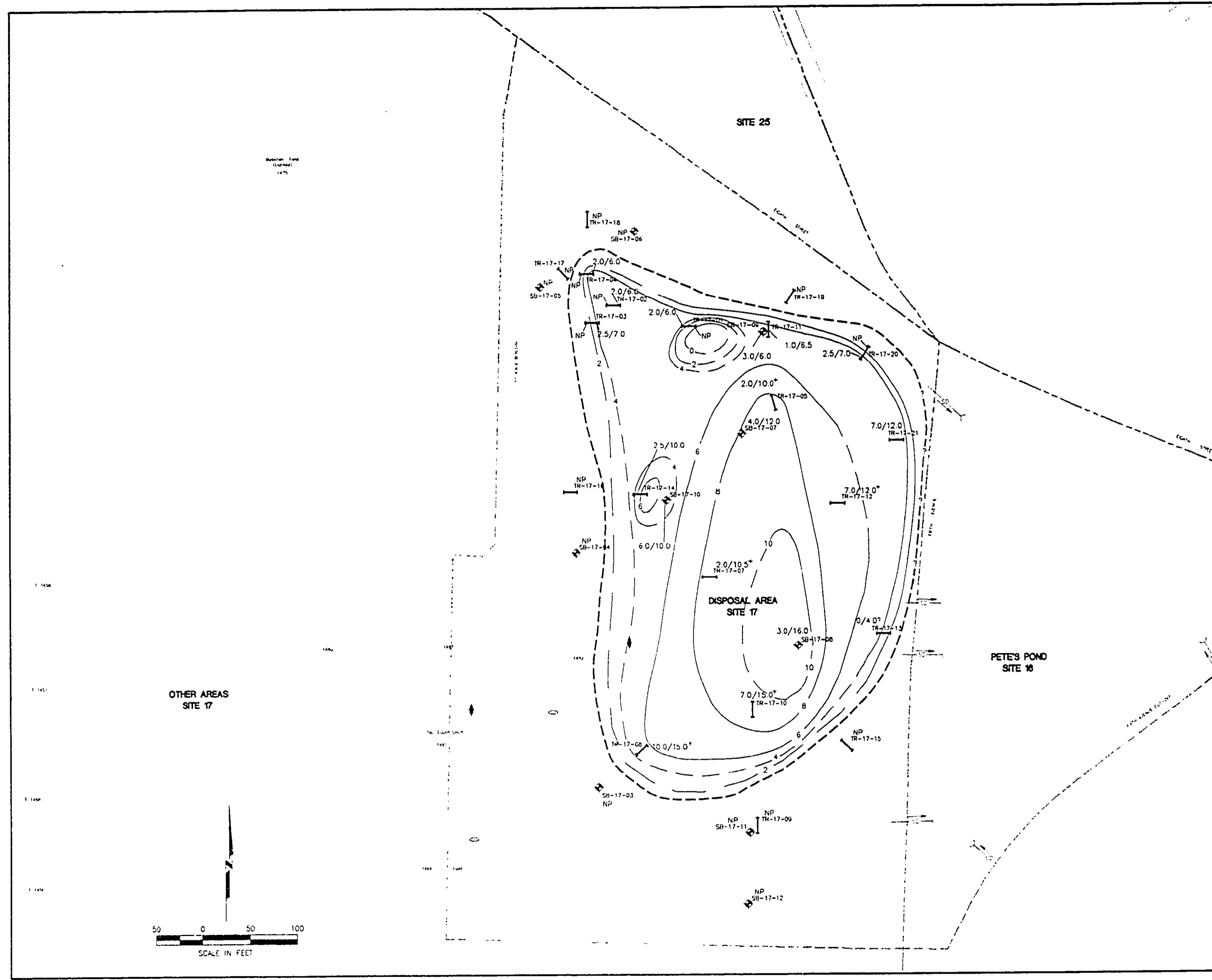

If this image is not as legible as this overlay, it's due to the poor quality of the original document

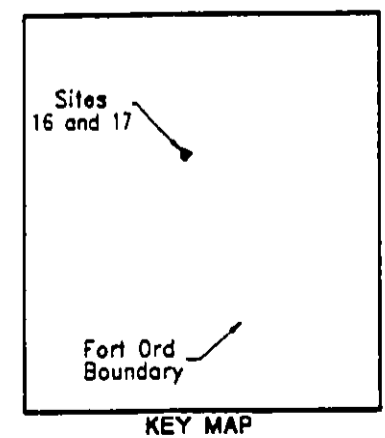

NO	DATE	REVISIONS	HLA FILE NO	PROJECT NO	APPROVED	APPROVAL DATE	DRAWN BY
1	7/94	DRAFT	23366135	23366 041711	REM	11/21/94	PH
2	12/94	DRAFT FINAL	23366135	23366 041721			PH

Harding Lawson Associates
 Engineering and Environmental Services

Volume II - Remedial Investigation
 Basewide RI/FS
 Fort Ord, California

Debris Thickness Map
 Site 17 - Disposal Area

If this image is not as legible as this overlay, it's due to the poor quality of the original document

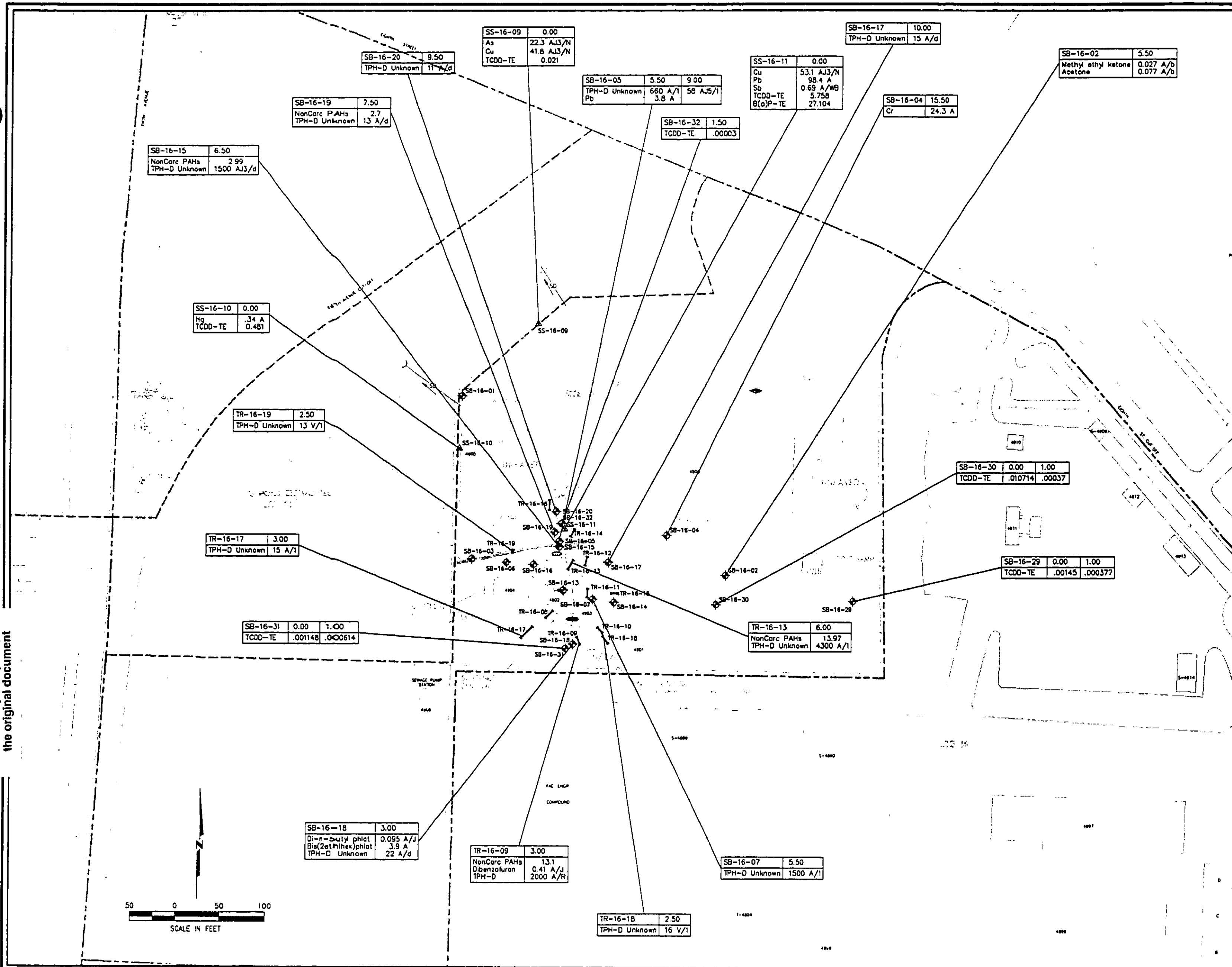

EXPLANATION

- TEST PIT
- SOIL GAS SAMPLING POINT (HLA)
- SURFACE SOIL SAMPLE (HLA)
- SOIL BORING/PILOT BORING (HLA)
- MONITORING WELL (HLA)
- SEDIMENT SAMPLE FROM STORM DRAIN OUTFALL PIPE
- CROSS-SECTION LINE
- FORMER UNDERGROUND STORAGE TANK
- EXISTING ABOVEGROUND STORAGE TANK
- WASH RACK
- OIL/WATER SEPARATOR
- SITE BOUNDARY
- AREA BOUNDARY
- BUILDING
- STORM DRAIN OUTFALL PIPE
- FENCE
- STORM DRAIN LINE

SAMPLE LOCATION

— SAMPLE DEPTH IN FEET BELOW GROUND SURFACE

SS-12-03	0.5
Pb	26.2 A
Zn	16.3 NJ

PROJECT AND LABORATORY QUALIFIERS: QUALIFIERS ARE DEFINED IN TABLES 41a AND 41b.

CONCENTRATIONS IN MILLIGRAMS PER KILOGRAM EXCEPT FOR TCDD-TE (IN MICROGRAMS PER KILOGRAM)

ANALYSES: ABBREVIATIONS ARE DEFINED IN THE LIST OF ACRONYMS AND ABBREVIATIONS. SEE NOTES.

ND(1.0) NOT DETECTED AT THE REPORTING LIMIT SHOWN IN PARENTHESES

NA NOT ANALYZED

NOTES:

- INCLUDES ALL INORGANICS EXCEEDING MAXIMUM BACKGROUND CONCENTRATIONS, DETECTED CONCENTRATIONS OF INORGANICS FOR WHICH BACKGROUND CONCENTRATIONS ARE NOT AVAILABLE, AND ALL DETECTED ORGANICS.
- NONCARCINOGENIC PAHS ARE PRESENTED AS A SUMMED TOTAL, DIOXINS AND FURANS AS A TCDD TOXIC EQUIVALENT (TCDD-TE) AND CARCINOGENIC PAHS AS A BENZO(a)PYRENE TOXIC EQUIVALENT (B(a)P-TE).

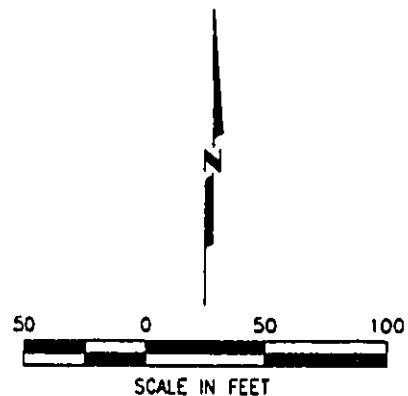
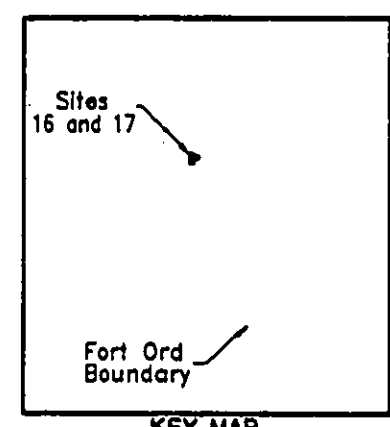

NO.	DATE	REVISIONS	HLA FILE NO	PROJECT NO	APPROVED	APPROVAL DATE	DRAWN BY
1	7/94	DRAFT	23366321	23366 041711			PH
2	12/94	DRAFT FINAL	23366321	23366 041721	RFA	11/23/94	PH

Harding Lawson Associates
Engineering and Environmental Services

Volume II - Remedial Investigation
Basewide RI/FS
Fort Ord, California

Distribution of Organic and Inorganic
Compounds Detected in Soil
Site 16 - DOL Maintenance Yard

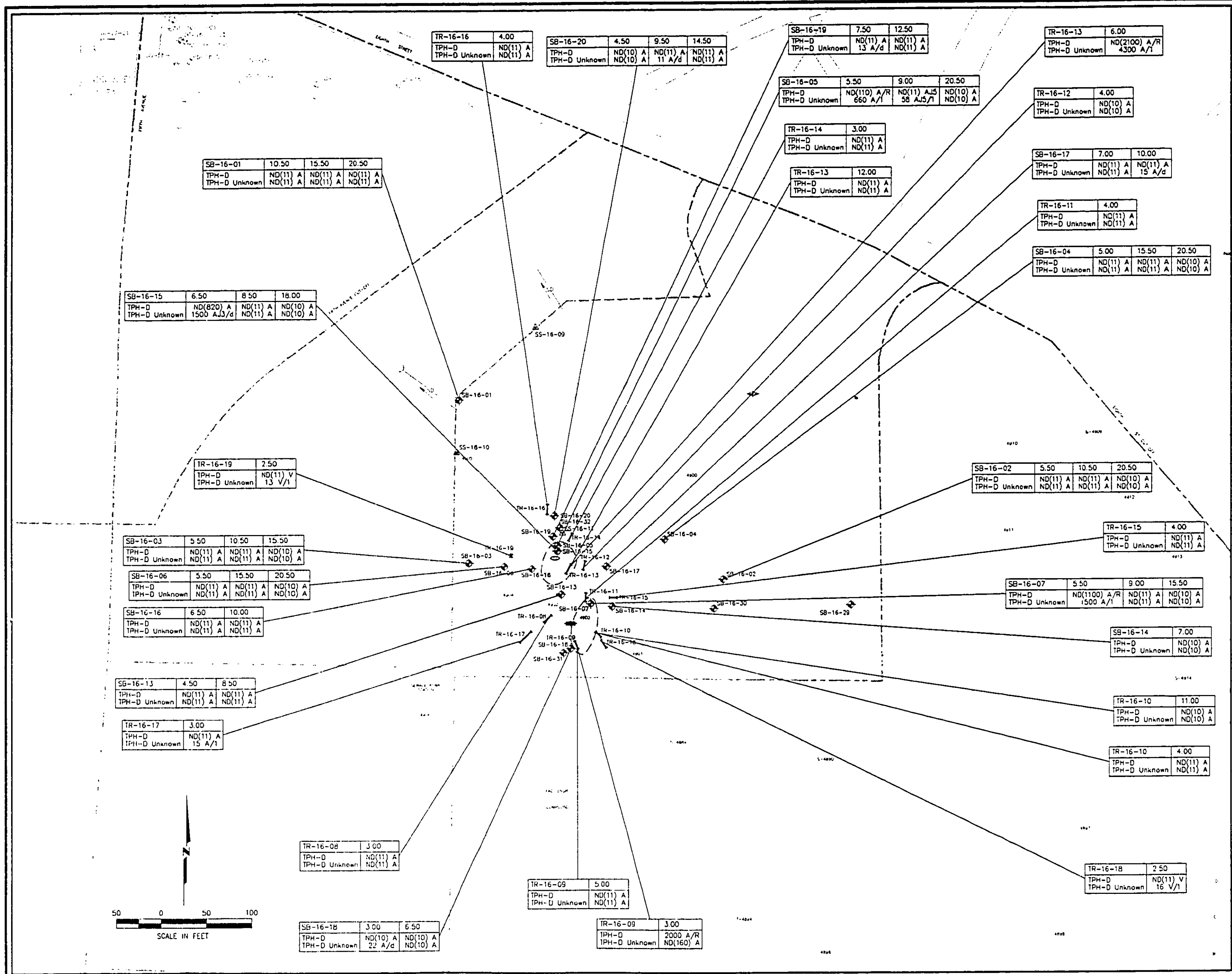

EXPLANATION

- TEST PIT
- SOIL GAS SAMPLING POINT (HLA)
- SURFACE SOIL SAMPLE (HLA)
- SOIL BORING (BY OTHERS)
- MONITORING WELL (HLA)
- SEDIMENT SAMPLE FROM STORM DRAIN OUTFALL PIPE
- CROSS-SECTION LINE
- FORMER UNDERGROUND STORAGE TANK
- EXISTING ABOVEGROUND STORAGE TANK
- WASH RACK
- OIL/WATER SEPARATOR
- SITE BOUNDARY
- AREA BOUNDARY
- BUILDING
- STORM DRAIN OUTFALL PIPE
- FENCE
- STORM DRAIN LINE
- APPROXIMATE EXTENT OF TPH CONCENTRATIONS (TPH AS DIESEL AND AS UNKNOWN TPH AS DIESEL) GREATER THAN 500 mg/kg

SAMPLE LOCATION
 SAMPLE DEPTH IN FEET BELOW GROUND SURFACE
SS-12-03 0.5
 Pb 26.2 A
 Zn 16.3 NJ

PROJECT AND LABORATORY QUALIFIERS ARE DEFINED IN TABLES 41c AND 41d.
 CONCENTRATIONS IN MILLIGRAMS PER KILOGRAM

ANALYSES - ABBREVIATIONS ARE DEFINED IN THE LIST OF ACRONYMS AND ABBREVIATIONS SEE NOTES.

ND(1.0) NOT DETECTED AT THE REPORTING LIMIT SHOWN IN PARENTHESES
 NA NOT ANALYZED

NOTES:
 1. CHEMICAL CONCENTRATION CONTOURS ARE BASED ON ONE INTERPRETATION OF THE DATA AVAILABLE WHEN THIS REPORT WAS PREPARED. OTHER INTERPRETATIONS MAY BE POSSIBLE.

If this image is not as legible as this overlay, it's due to the poor quality of the original document

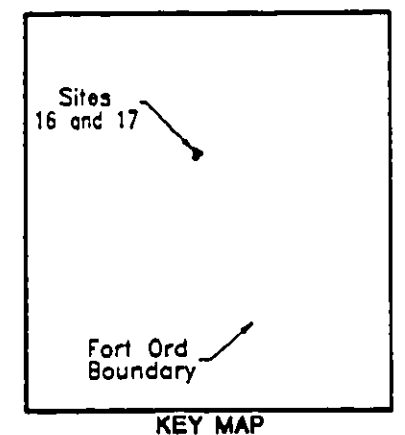

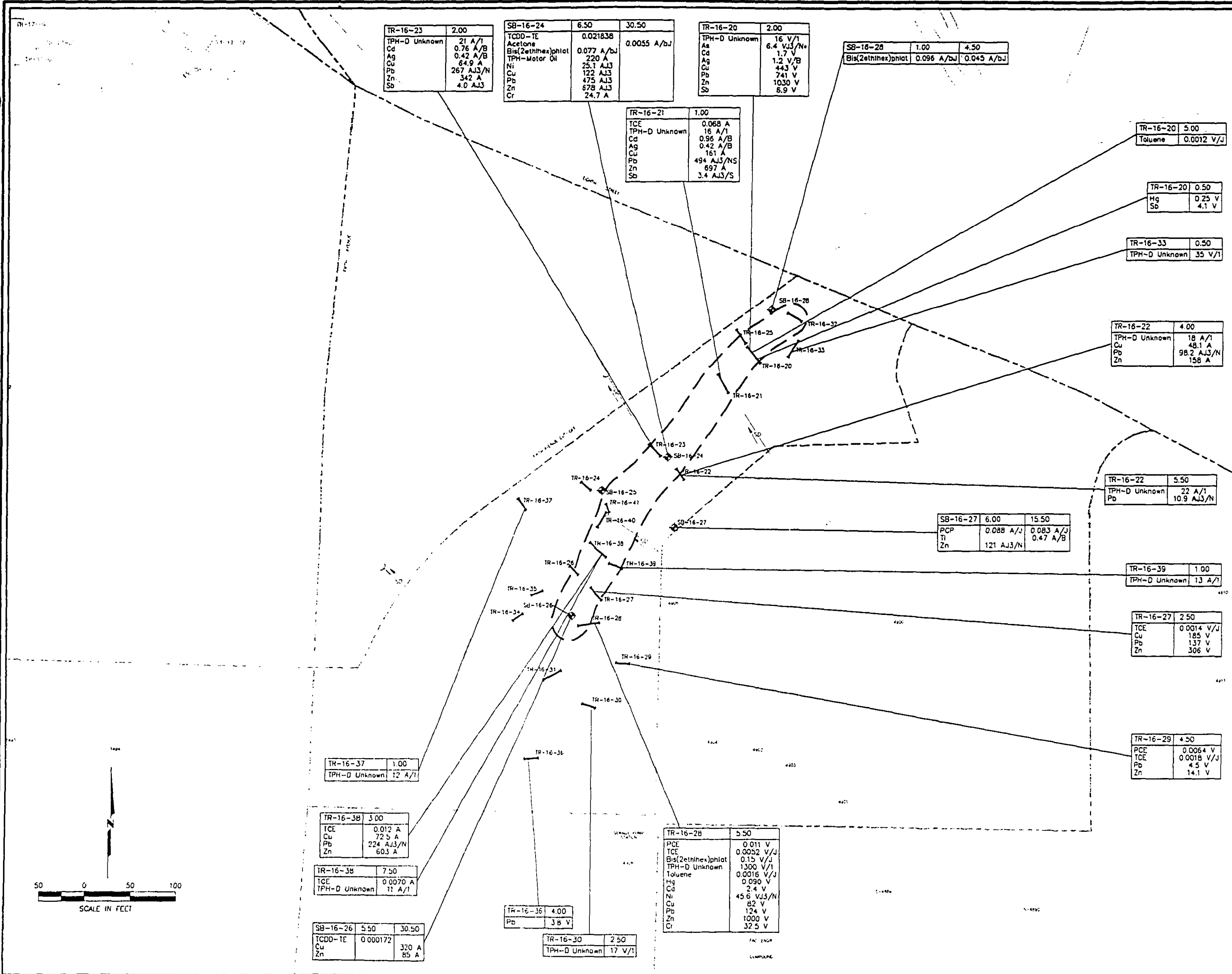

- ### EXPLANATION
- TEST PIT
 - SOIL GAS SAMPLING POINT (HLA)
 - SURFACE SOIL SAMPLE (HLA)
 - SOIL BORING/PILOT BORING (HLA)
 - MONITORING WELL (HLA)
 - SEDIMENT SAMPLE FROM STORM DRAIN OUTFALL PIPE
 - CROSS-SECTION LINE
 - FORMER UNDERGROUND STORAGE TANK
 - EXISTING ABOVEGROUND STORAGE TANK
 - WASH RACK
 - OIL/WATER SEPARATOR
 - SITE BOUNDARY
 - AREA BOUNDARY
 - BUILDING
 - STORM DRAIN OUTFALL PIPE
 - FENCE
 - STORM DRAIN LINE
 - EXTENT OF SUBSURFACE DEBRIS
- SAMPLE LOCATION**
- SAMPLE DEPTH IN FEET BELOW GROUND SURFACE
- SS-12-03 0.5**
- | | |
|----|---------|
| Pb | 26.2 A |
| Zn | 16.3 NJ |
- PROJECT AND LABORATORY QUALIFIERS:**
QUALIFIERS ARE DEFINED IN TABLES 41c AND 41b.
- CONCENTRATIONS IN MILLIGRAMS PER KILOGRAM EXCEPT FOR TCDD-TE (IN MICROGRAMS PER KILOGRAM)**
- ANALYTES:**
ABBREVIATIONS ARE DEFINED IN THE LIST OF ACRONYMS AND ABBREVIATIONS. SEE NOTES.
- ND(1C) NOT DETECTED AT THE REPORTING LIMIT SHOWN IN PARENTHESES
- NA NOT ANALYZED
- NOTES**
- INCLUDES ALL INORGANICS EXCEEDING MAXIMUM BACKGROUND CONCENTRATIONS, DETECTED CONCENTRATIONS OF INORGANICS FOR WHICH BACKGROUND CONCENTRATIONS ARE NOT AVAILABLE, AND ALL DETECTED ORGANICS.
 - NONCARCINOGENIC PAHS ARE PRESENTED AS A SUMMED TOTAL, DIOXINS AND FURANS AS A TCDD TOXIC EQUIVALENT (TCDD-TE).

If this image is not as legible as this overlay, it's due to the poor quality of the original document

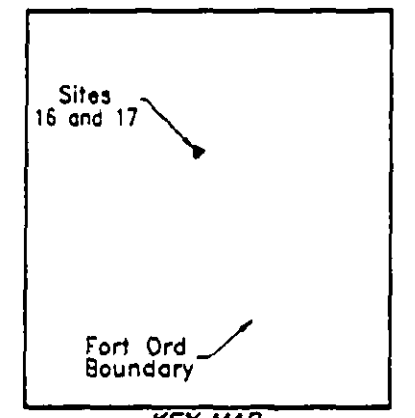

If this image is not as legible as this overlay, it's due to the poor quality of the original document

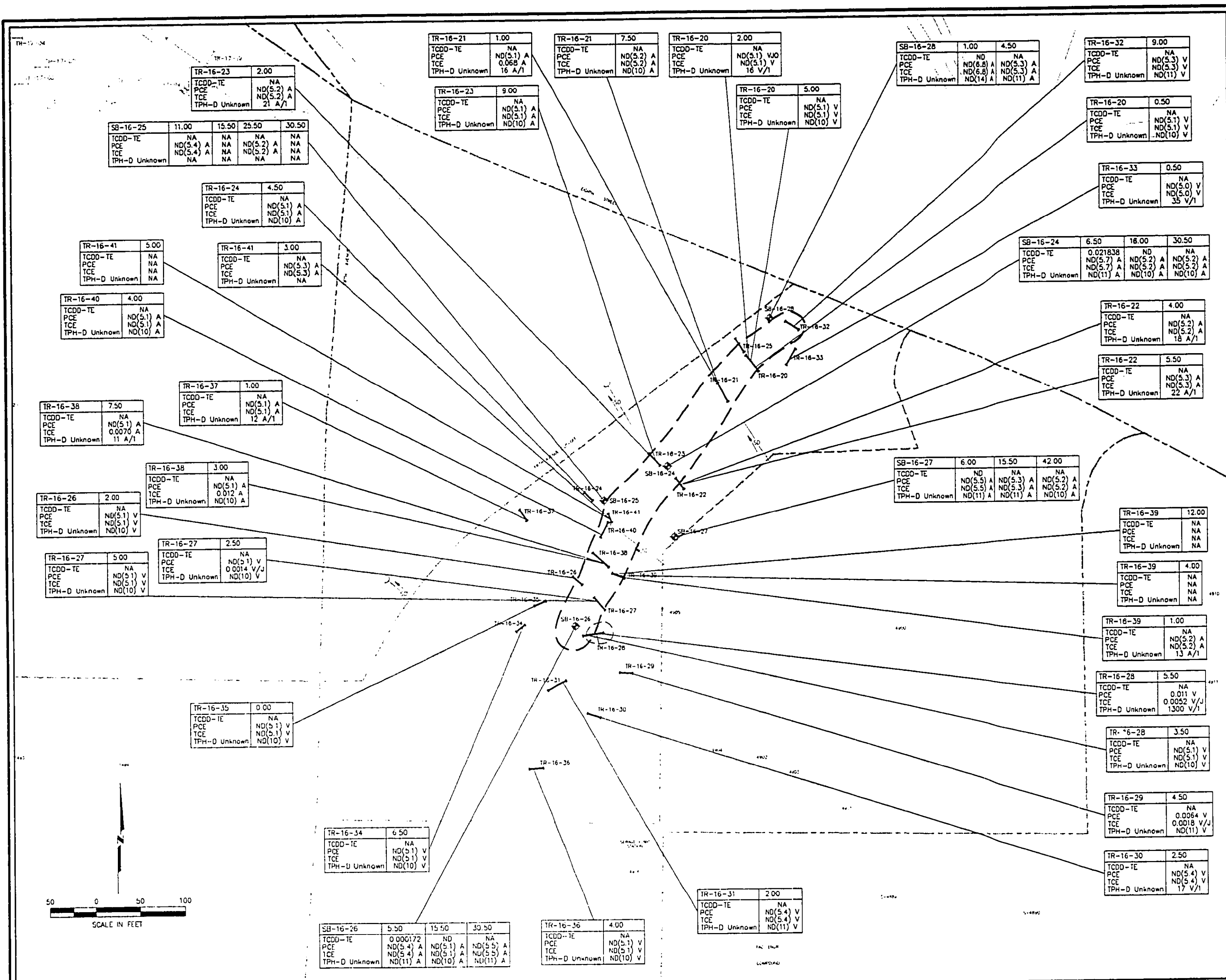

EXPLANATION

- I TEST PIT
- SOIL GAS SAMPLING POINT (HLA)
- SURFACE SOIL SAMPLE (HLA)
- ◆ SOIL BORING/PILOT BORING (HLA)
- MONITORING WELL (HLA)
- SEDIMENT SAMPLE FROM STORM DRAIN OUTFALL PIPE
- CROSS-SECTION LINE
- FORMER UNDERGROUND STORAGE TANK
- EXISTING ABOVEGROUND STORAGE TANK
- WASH RACK
- OIL/WATER SEPARATOR
- SITE BOUNDARY
- AREA BOUNDARY
- BUILDING
- STORM DRAIN OUTFALL PIPE
- FENCE
- STORM DRAIN LINE
- APPROXIMATE EXTENT OF TPH CONCENTRATIONS (UNKNOWN TPH AS DIESEL) GREATER THAN 500 mg/kg
- EXTENT OF SUBSURFACE DEBRIS

SAMPLE LOCATION

SS-12-03	0.5
Pb	26.2 A
Zn	16.3 NJ

PROJECT AND LABORATORY QUALIFIERS; QUALIFIERS ARE DEFINED IN TABLES 41c AND 41b.

CONCENTRATIONS IN MILLIGRAMS PER KILOGRAM EXCEPT FOR TCDD-TE (IN MICROGRAMS PER KILOGRAM)

ANALYTES - ABBREVIATIONS ARE DEFINED IN THE LIST OF ACRONYMS AND ABBREVIATIONS. SEE NOTES.

ND(1.0) NOT DETECTED AT THE REPORTING LIMIT SHOWN IN PARENTHESES

NA NOT ANALYZED

NOTES:

1. DIOXINS AND FURANS ARE PRESENTED AS A TCDD TOXIC EQUIVALENT (TCDD-TE).

2. CHEMICAL CONCENTRATION CONTOURS ARE BASED ON ONE INTERPRETATION OF THE DATA AVAILABLE WHEN THIS REPORT WAS PREPARED. OTHER INTERPRETATIONS MAY BE POSSIBLE.

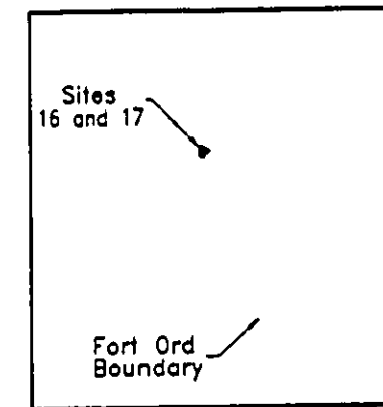

NO.	DATE	REVISIONS	HLA FILE NO	PROJECT NO	APPROVED	APPROVAL DATE	DRAWN BY
1	7/94	DRAFT	23366334	23366 041711			PH
2	12/94	DRAFT FINAL	23366334	23366 041721	RM	11/21/97	PH

Harding Lawson Associates
Engineering and Environmental Services

Volume II - Remedial Investigation
Basewide R/FS
Fort Ord, California

Distribution of Selected
Organic Compounds Detected in Soil
Site 16 - Pete's Pond Extension

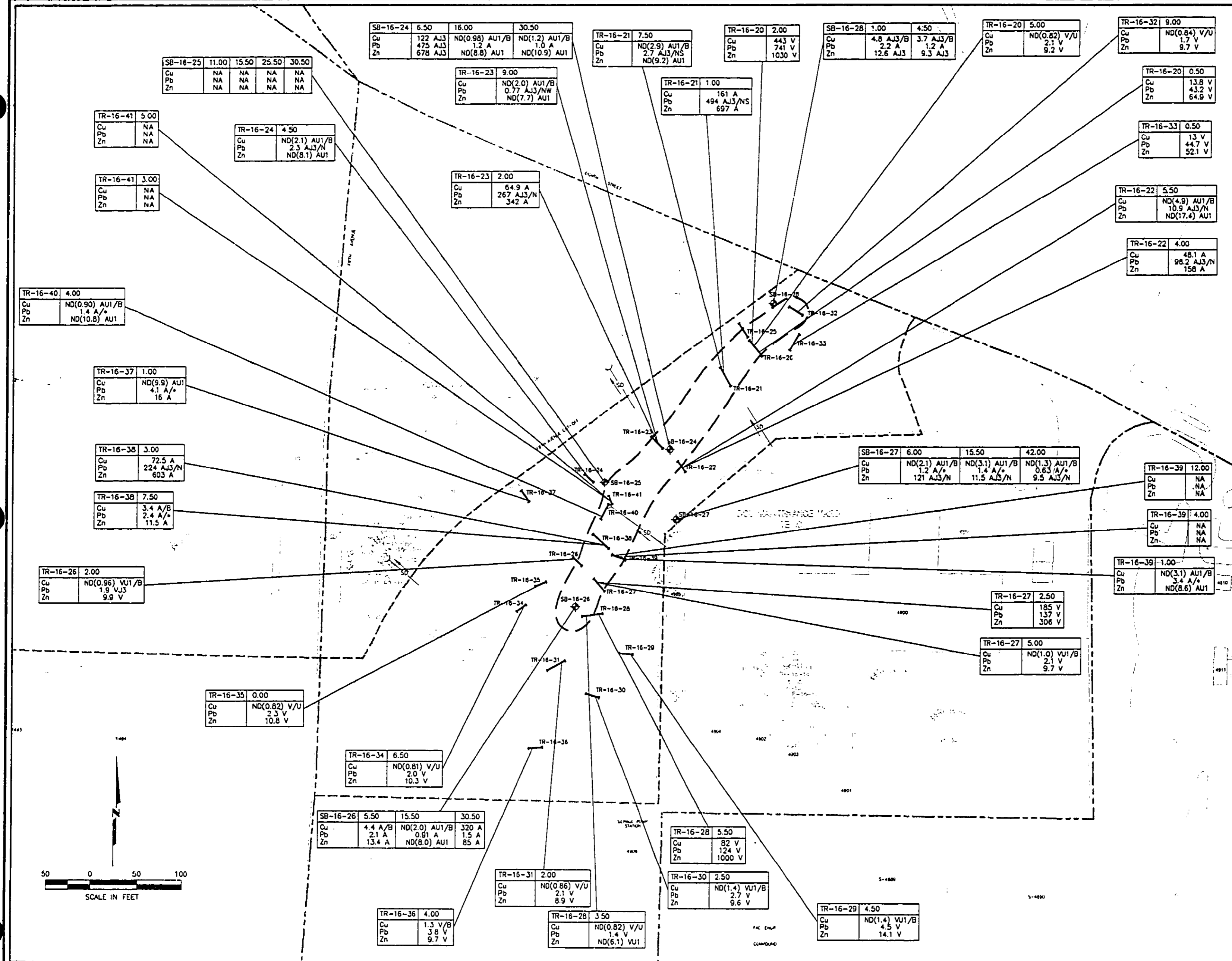

- ### EXPLANATION
- TEST PIT
 - SOIL GAS SAMPLING POINT (HLA)
 - SURFACE SOIL SAMPLE (HLA)
 - SOIL BORING/PILOT BORING (HLA)
 - MONITORING WELL (HLA)
 - SEDIMENT SAMPLE FROM STORM DRAIN OUTFALL PIPE
 - CROSS-SECTION LINE
 - FORMER UNDERGROUND STORAGE TANK
 - EXISTING ABOVEGROUND STORAGE TANK
 - WASH RACK
 - OIL/WATER SEPARATOR
 - SITE BOUNDARY
 - AREA BOUNDARY
 - BUILDING
 - STORM DRAIN OUTFALL PIPE
 - FENCE
 - STORM DRAIN LINE
 - EXTENT OF SUBSURFACE DEBRIS
- SAMPLE LOCATION**
- SAMPLE DEPTH IN FEET BELOW GROUND SURFACE
- | | |
|----------|---------|
| SS-12-03 | 0.5 |
| Pb | 26.2 A |
| Zn | 16.3 NJ |
- PROJECT AND LABORATORY QUALIFIERS: QUALIFIERS ARE DEFINED IN TABLES 410 AND 411.
- CONCENTRATIONS IN MILLIGRAMS PER KILOGRAM
- ANALYTES— ABBREVIATIONS ARE DEFINED IN THE LIST OF ACRONYMS AND ABBREVIATIONS.
- ND(1.0) NOT DETECTED AT THE REPORTING LIMIT SHOWN IN PARENTHESES
- NA NOT ANALYZED

If this image is not as legible as this overlay, it's due to the poor quality of the original document

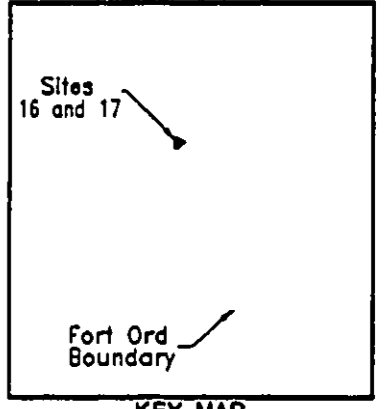

NO.	DATE	REVISIONS	HLA FILE NO.	PROJECT NO.	APPROVED	APPROVAL DATE	DRAWN BY
1	7/94	DRAFT	23366335	23366 041711			PH
2	12/94	DRAFT FINAL	23366335	23366 041721	RSM	11/21/99	PH

Harding Lawson Associates
Engineering and Environmental Services

Volume II - Remedial Investigation
Basewide RI/FS
Fort Ord, California

Distribution of Selected Inorganic
Compounds Detected in Soil
Site 16 - Pete's Pond Extension

PLATE: **27**

If this image is not as legible as this overlay, it's due to the poor quality of the original document

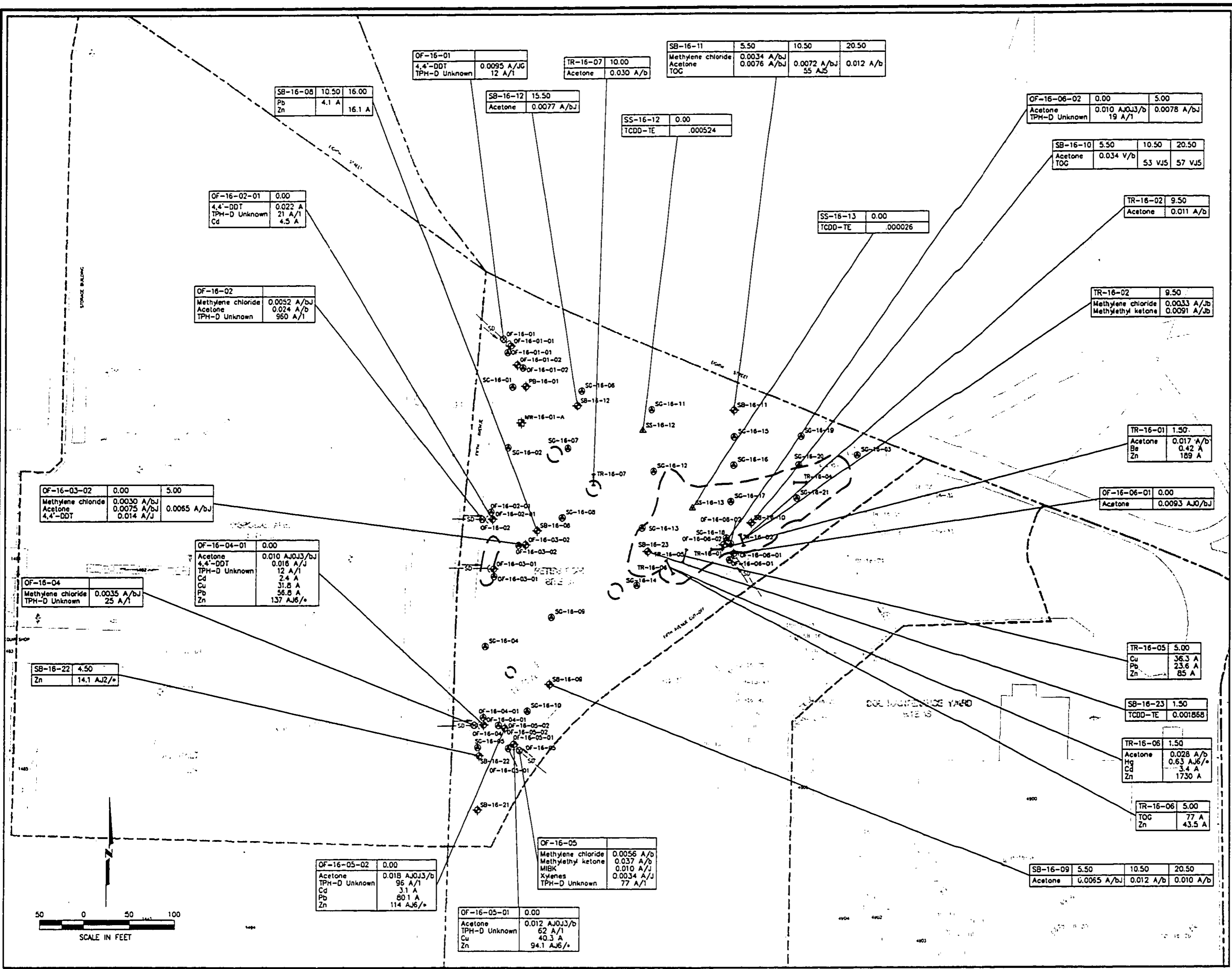

EXPLANATION

- ⊠ TEST PIT
- ⊙ SOIL GAS SAMPLING POINT (HLA)
- ⊕ SURFACE SOIL SAMPLE (HLA)
- ⊕ SOIL BORING/PILOT BORING (HLA)
- ⊕ MONITORING WELL (HLA)
- ⊕ SEDIMENT SAMPLE FROM STORM DRAIN OUTFALL PIPE
- CROSS-SECTION LINE
- FORMER UNDERGROUND STORAGE TANK
- EXISTING ABOVEGROUND STORAGE TANK
- WASH RACK
- GREASE RACK
- OIL/WATER SEPARATOR
- SITE BOUNDARY
- AREA BOUNDARY
- BUILDING
- STORM DRAIN OUTFALL PIPE
- FENCE
- STORM DRAIN LINE
- EXTENT OF SUBSURFACE DEBRIS AS DEFINED WITH GEOPHYSICAL ANOMALIES

SAMPLE LOCATION
 SAMPLE DEPTH IN FEET BELOW GROUND SURFACE

SS-12-03	0.5
Pb	28.2 A
Zn	16.3 NJ

PROJECT AND LABORATORY QUALIFIERS: QUALIFIERS ARE DEFINED IN TABLES 41a AND 41b.
 CONCENTRATIONS IN MILLIGRAMS PER KILOGRAM EXCEPT FOR TCDD-TE (IN MICROGRAMS PER KILOGRAM)
 ANALYTES- ABBREVIATIONS ARE DEFINED IN THE LIST OF ACRONYMS AND ABBREVIATIONS. SEE NOTES.

ND(1.0) NOT DETECTED AT THE REPORTING LIMIT SHOWN IN PARENTHESES
 NA NOT ANALYZED

- NOTES:**
1. INCLUDES ALL INORGANICS EXCEEDING MAXIMUM BACKGROUND CONCENTRATIONS, DETECTED CONCENTRATIONS OF INORGANICS FOR WHICH BACKGROUND CONCENTRATIONS ARE NOT AVAILABLE, AND ALL DETECTED ORGANICS.
 2. NONCARCINOGENIC PAHS ARE PRESENTED AS A SUMMED TOTAL. DIOXINS AND FURANS AS A TCDD TOXIC EQUIVALENT (TCDD-TE), AND CARCINOGENIC PAHS AS BENZO(A)PYRENE TOXIC EQUIVALENT (B(a)P-TE).

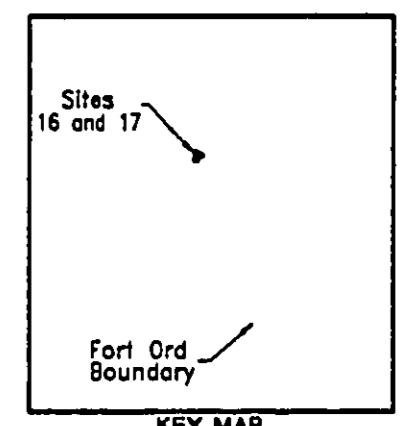

NO.	DATE	REVISIONS	HLA FILE NO.	PROJECT NO.	APPROVED	APPROVAL DATE	DRAWN BY	Harding Lawson Associates Engineering and Environmental Services	Volume II - Remedial Investigation Basewide RI/FS Fort Ord, California	Distribution of Organic and Inorganic Compounds Detected in Soil and Sediment Site 16 - Pete's Pond	PLATE: 28
1	7/94	DRAFT	23366486	23366 041711	PH		PH				
2	12/94	DRAFT FINAL	23366486	23366 041721	PH	11/25/99	PH				

If this image is not as legible as this overlay, it's due to the poor quality of the original document

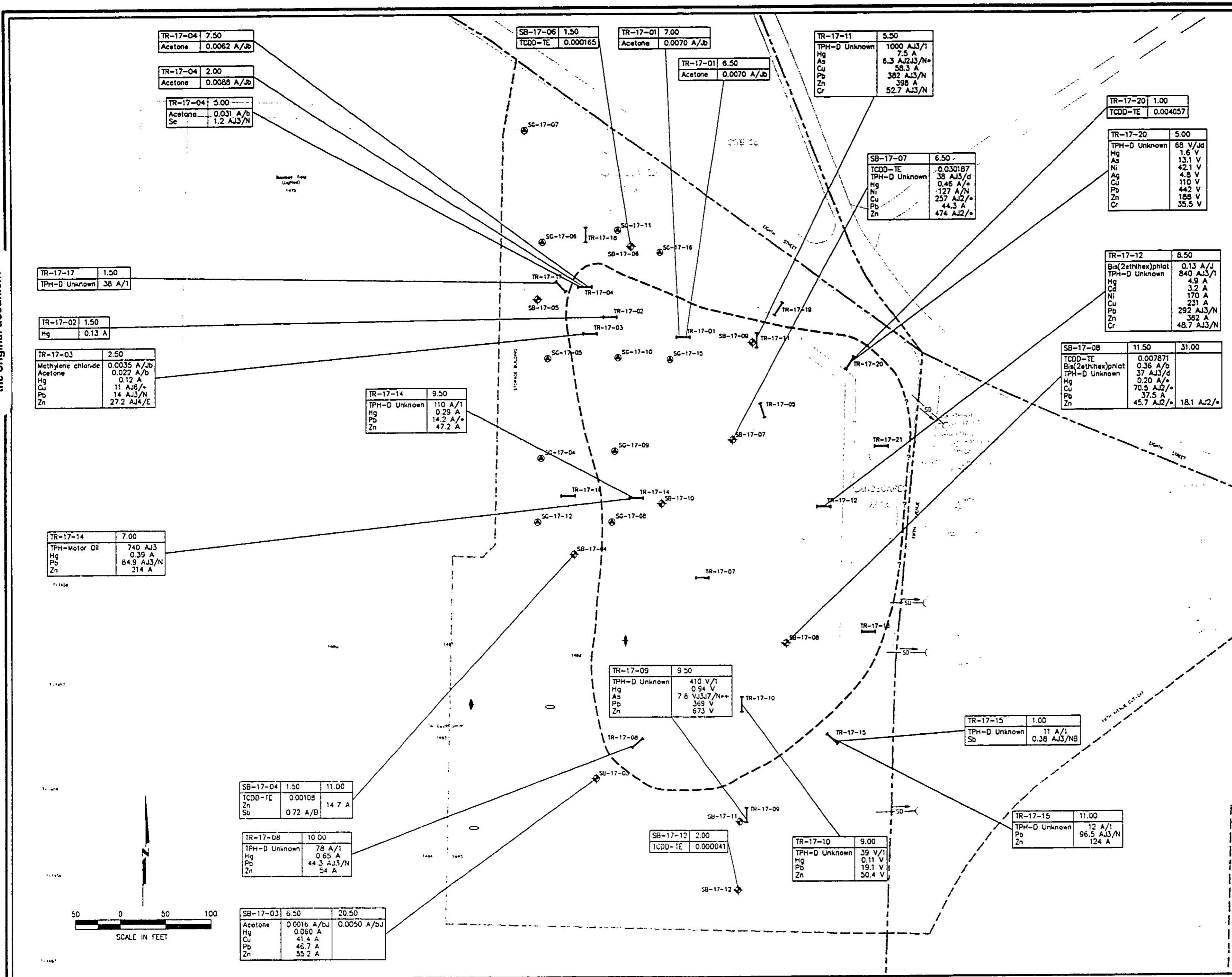

EXPLANATION

- ⊖ TEST PIT
- ⊙ SOIL GAS SAMPLING POINT (HLA)
- ⊕ SURFACE SOIL SAMPLE (HLA)
- ⊖ SOIL BORING/PILOT BORING (HLA)
- ⊖ MONITORING WELL (HLA)
- ⊖ SEDIMENT SAMPLE FROM STORM DRAIN OUTFALL PIPE
- CROSS-SECTION LINE
- ⊖ EXISTING UNDERGROUND STORAGE TANK
- ⊖ FORMER UNDERGROUND STORAGE TANK
- ⊖ WASH RACK
- ⊖ GREASE RACK
- ⊖ OIL/WATER SEPARATOR
- SITE BOUNDARY
- AREA BOUNDARY
- ⊖ BUILDING
- STORM DRAIN OUTFALL PIPE
- FENCE
- STORM DRAIN LINE
- EXTENT OF SUBSURFACE DEBRIS

SAMPLE LOCATION

SS-12-03 0.5
Pb 26.2 A
Zn 16.3 NJ

PROJECT AND LABORATORY QUALIFIERS ARE DEFINED IN TABLES 41a AND 41b.

CONCENTRATIONS IN MILLIGRAMS PER KILOGRAM EXCEPT FOR TCDD-TE (IN MICROGRAMS PER KILOGRAM)

ANALYSES- ABBREVIATIONS ARE DEFINED IN THE LIST OF ACRONYMS AND ABBREVIATIONS. SEE NOTES.

ND(1.0) NOT DETECTED AT THE REPORTING LIMIT SHOWN IN PARENTHESES

NA NOT ANALYZED

NOTES:

1. INCLUDES ALL INORGANICS EXCEEDING MAXIMUM BACKGROUND CONCENTRATIONS, DETECTED CONCENTRATIONS OF INORGANICS FOR WHICH BACKGROUND CONCENTRATIONS ARE NOT AVAILABLE, AND ALL DETECTED ORGANICS.
2. NONCARCINOGENIC PAHS ARE PRESENTED AS A SUMMED TOTAL. DIOXINS AND FURANS AS A TCDD TOXIC EQUIVALENT (TCDD-TE) AND CARCINOGENIC PAHS AS A BENZO(A)PYRENE TOXIC EQUIVALENT (B(a)P-TE).

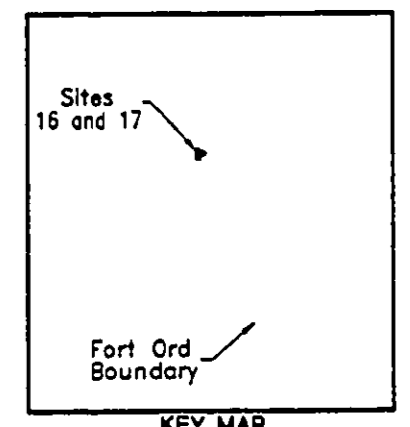

NO.	DATE	REVISIONS	HLA FILE NO	PROJECT NO	APPROVED	APPROVAL DATE	DRAWN BY	Harding Lawson Associates Engineering and Environmental Services	Volume II - Remedial Investigation Basewide RI/FS Fort Ord, California	Distribution of Organic and Inorganic Compounds Detected in Soil Site 17 - Disposal Area	PLATE: 29
1	7/94	DRAFT	23366329	23366 041711	PH		PH				
2	12/94	DRAFT FINAL	23366329	23366 041721	PH	11/21/94	PH				

EXPLANATION

- TEST PIT
- SOIL GAS SAMPLING POINT (HLA)
- SURFACE SOIL SAMPLE (HLA)
- SOIL BORING/PILOT BORING (HLA)
- MONITORING WELL (HLA)
- SEDIMENT SAMPLE FROM STORM DRAIN OUTFALL PIPE
- CROSS-SECTION LINE
- FORMER UNDERGROUND STORAGE TANK
- EXISTING ABOVEGROUND STORAGE TANK
- WASH RACK
- GREASE RACK
- OIL/WATER SEPARATOR
- SITE BOUNDARY
- AREA BOUNDARY
- BUILDING
- STORM DRAIN OUTFALL PIPE
- FENCE
- STORM DRAIN LINE
- APPROXIMATE EXTENT OF TPH (AS DIESEL AND UNKNOWN TPH AS DIESEL) IN SOIL ABOVE 500 mg/kg
- APPROXIMATE EXTENT OF SUBSURFACE DEBRIS; DASHED WHERE INFERRED, QUERIED WHERE UNCERTAIN

SAMPLE LOCATION

SS-12-03	0.5
Pb	26.2 A
Zn	16.3 NJ

PROJECT AND LABORATORY QUALIFIERS: QUALIFIERS ARE DEFINED IN TABLES 41a AND 41b.
CONCENTRATIONS IN MILLIGRAMS PER KILOGRAM

ANALYTES - ABBREVIATIONS ARE DEFINED IN THE LIST OF ACRONYMS AND ABBREVIATIONS. SEE NOTE.

ND(10) NOT DETECTED AT THE REPORTING LIMIT SHOWN IN PARENTHESES

NA NOT ANALYZED

NOTE: 1. CHEMICAL CONCENTRATION CONTOURS ARE BASED ON ONE INTERPRETATION OF THE DATA AVAILABLE WHEN THIS REPORT WAS PREPARED. OTHER INTERPRETATIONS MAY BE POSSIBLE.

If this image is not as legible as this overlay, it's due to the poor quality of the original document

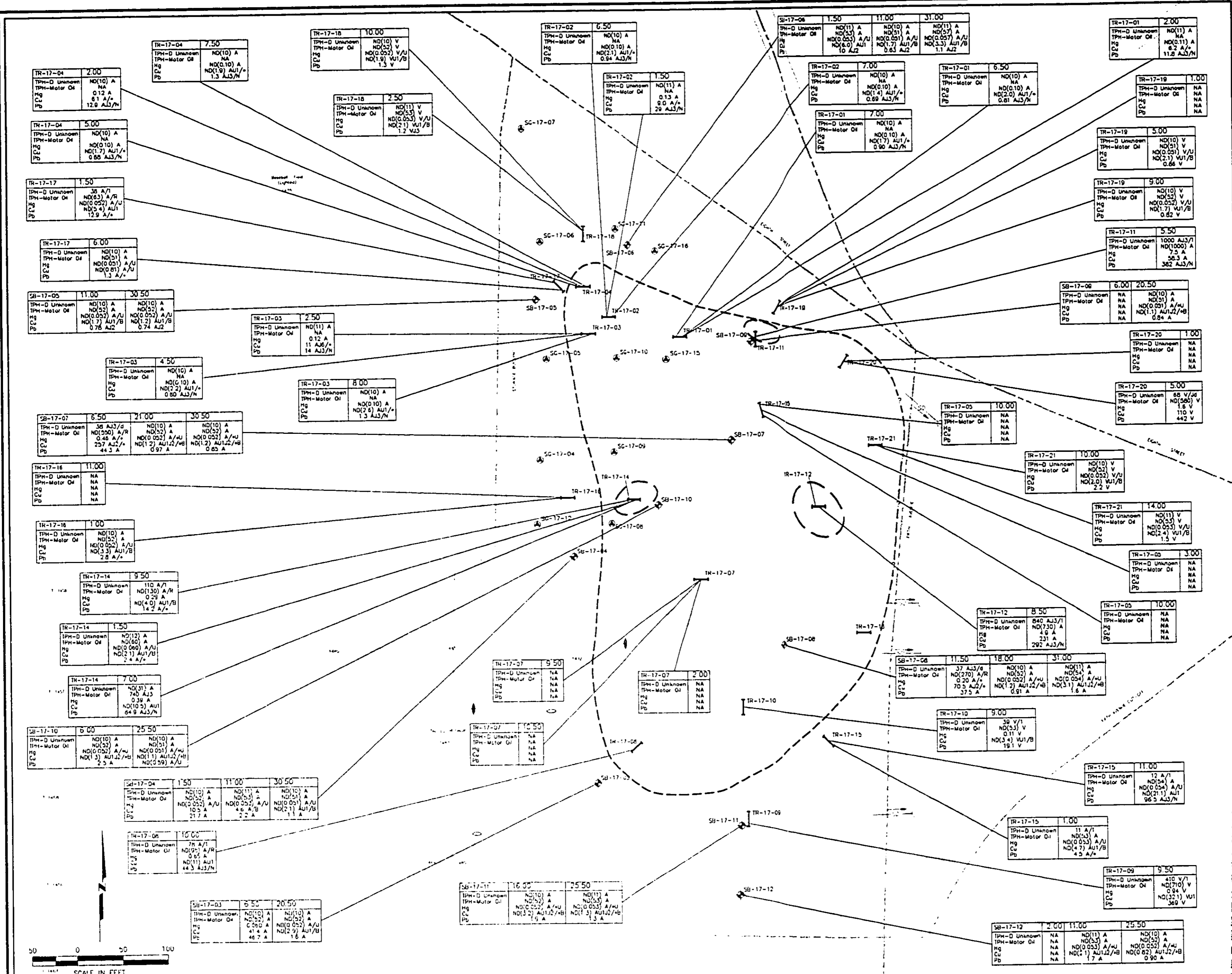
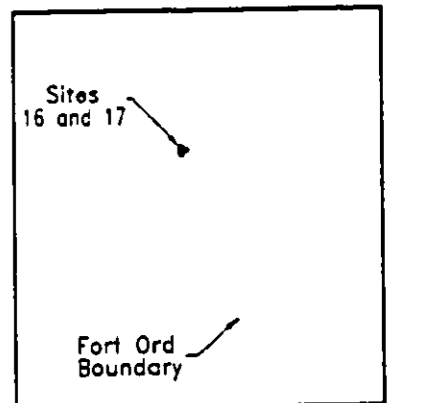

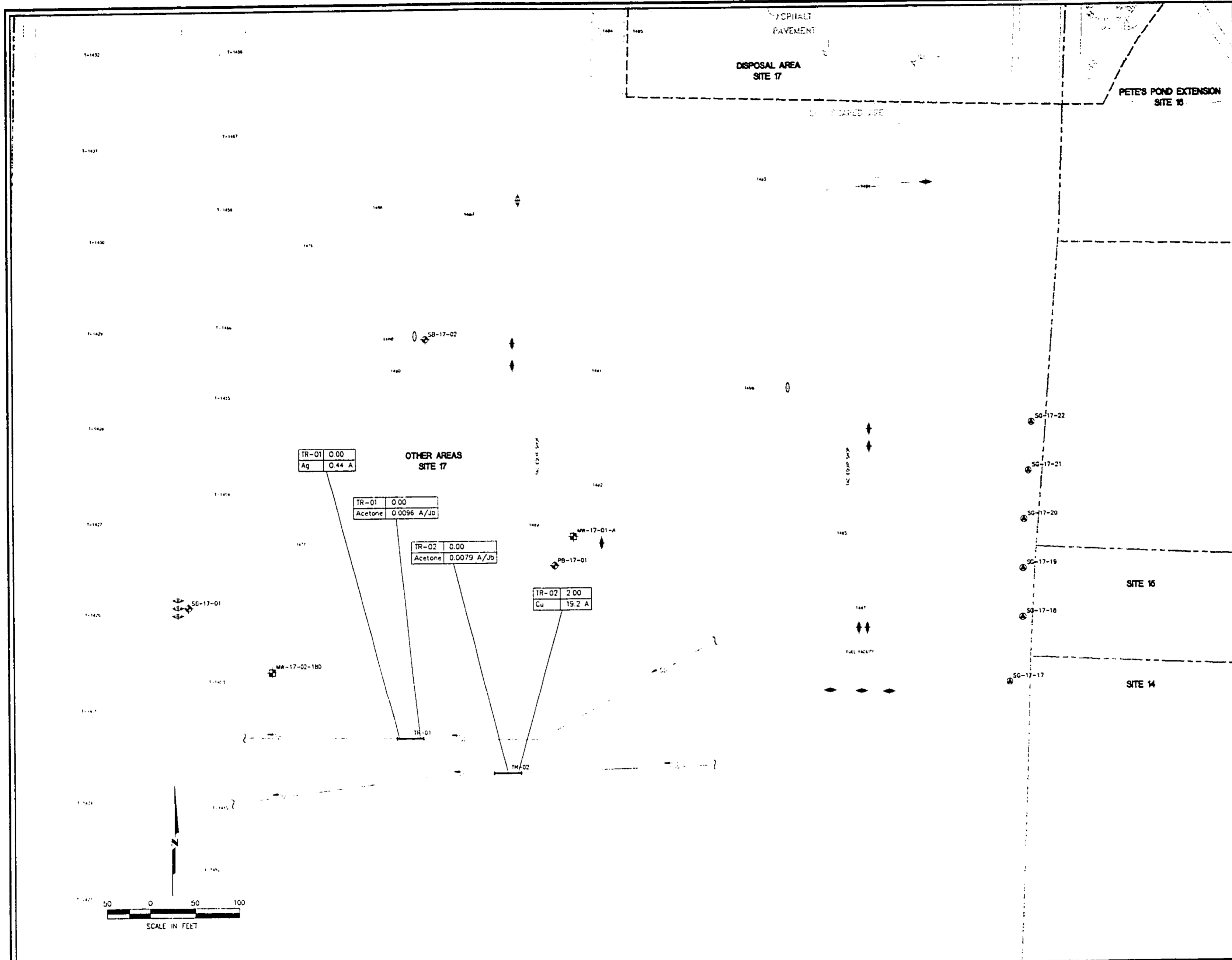

- EXPLANATION**
- ⊠ TEST PIT
 - ⊙ SOIL GAS SAMPLING POINT (HLA)
 - ⊕ SOIL BORING/PILOT BORING (HLA)
 - ⊖ MONITORING WELL (HLA)
 - ⊖ SEDIMENT SAMPLE FROM STORM DRAIN OUTFALL PIPE
 - ◊ EXISTING UNDERGROUND STORAGE TANK
 - ◊ FORMER UNDERGROUND STORAGE TANK
 - WASH RACK
 - GREASE RACK
 - OIL/WATER SEPARATOR
 - SITE BOUNDARY
 - AREA BOUNDARY
 - BUILDING
 - STORM DRAIN OUTFALL PIPE
 - FENCE
 - SD --- STORM DRAIN LINE
 - SS --- SANITARY SEWER LINE
- SAMPLE LOCATION**
- SAMPLE DEPTH IN FEET BELOW GROUND SURFACE
- PROJECT AND LABORATORY QUALIFIERS: QUALIFIERS ARE DEFINED IN TABLES 41a AND 41b.
- CONCENTRATIONS IN MILLIGRAMS PER KILOGRAM
- ANALYTES-- ABBREVIATIONS ARE DEFINED IN THE LIST OF ACRONYMS AND ABBREVIATIONS. SEE NOTE.
- ND(1.0) NOT DETECTED AT THE REPORTING LIMIT SHOWN IN PARENTHESES
- NA NOT ANALYZED
- NOTE:
1. INCLUDES ALL INORGANICS EXCEEDING MAXIMUM BACKGROUND CONCENTRATIONS, DETECTED CONCENTRATIONS OF INORGANICS FOR WHICH BACKGROUND CONCENTRATIONS ARE NOT AVAILABLE, AND ALL DETECTED ORGANICS.

If this image is not as legible as this overlay, it's due to the poor quality of the original document

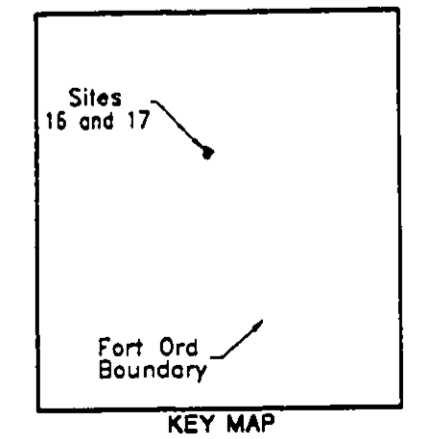

NO	DATE	REVISIONS	HLA FILE NO.	PROJECT NO.	APPROVED	APPROVAL DATE	DRAWN BY
1	7/94	DRAFT	23366323	23366 041711			AED
2	12/94	DRAFT FINAL	23366323	23366 041721	REM	11/21/99	AED

Harding Lawson Associates
Engineering and Environmental Services

Volume II - Remedial Investigation
Basewide RI/FS
Fort Ord, California

Distribution of Organic and Inorganic
Compounds Detected in Soil
Site 17 - Other Areas

EXPLANATION

- ⊕ MONITORING WELL (HLA)
- ⊕ MONITORING WELL (EA)
- 16/17A 15/17A CROSS-SECTION LINE
- WASH RACK
- GREASE RACK
- FORMER HAZARDOUS WASTE STORAGE AREA
- SITE BOUNDARY
- - - AREA BOUNDARY
- ▭ BUILDING
- ▭ FENCE
- SAMPLE LOCATION
- SAMPLE COLLECTION DATE
- SS-12-03 03/10/94
PCE 26.2 A
TCE 16.3 NJ
- PROJECT AND LABORATORY QUALIFIERS; QUALIFIERS ARE DEFINED IN TABLES 41a AND 41b
- CONCENTRATIONS IN MICROGRAMS PER LITER
- ANALYTES - ABBREVIATIONS ARE DEFINED IN THE LIST OF ACRONYMS AND ABBREVIATIONS. SEE NOTES.
- ND(1.0) NOT DETECTED AT THE REPORTING LIMIT SHOWN IN PARENTHESES
- NA NOT ANALYZED
- - - APPROXIMATE WESTERN EDGE OF FORT ORD-SALINAS VALLEY AQUICLUD (FO-SVA)
- - - TOTAL VOC CONCENTRATION CONTOUR IN MICROGRAMS PER LITER; FEBRUARY-MARCH 1994 SAMPLING ROUND.

MW-18-02-180	03/19/92	03/26/92	05/06/92	06/04/92	09/20/93	12/08/93	02/28/94
Carbon Tet	NA	ND(5.0) V	ND(5.0) A	ND(5.0) A	NA	ND(0.50) A	NA
PCE	NA	ND(5.0) V	ND(5.0) A	ND(5.0) A	NA	1.9 A	NA
TCE	NA	ND(5.0) V	ND(5.0) A	ND(5.0) A	NA	0.88 A	NA
Total VOCs							

MW-18-03-180	03/19/92	03/26/92	05/06/92	06/04/92	09/20/93	12/09/93	02/28/94
Carbon Tet	NA	ND(5.0) V	ND(5.0) A	ND(5.0) A	ND(0.50) A	ND(0.50) A	ND(0.50) A
PCE	NA	ND(5.0) V	ND(22) AU2	ND(5.0) A	1.6 A	0.58 A	1.8 A
TCE	NA	ND(5.0) V	7.3 A	4.3 A/J	5.2 A	6.8 A	7.0 A
Total VOCs							9.56

MW-18-01-180	03/19/92	03/26/92	05/06/92	06/04/92	09/21/93	12/09/93	02/28/94
Carbon Tet	NA	ND(5.0) V	ND(5.0) A	ND(5.0) A	NA	ND(0.50) A	NA
PCE	NA	ND(5.0) V	ND(2.7) AU2/J	ND(5.0) A	NA	0.96 A	NA
TCE	NA	ND(5.0) V	ND(5.0) A	ND(5.0) A	NA	0.35 A/J	NA
Total VOCs							

MW-17-02-180	03/30/92	05/08/92	06/05/92	09/16/93	12/10/93	02/25/94
Carbon Tet	85 A	ND(5.0) A	ND(5.0) A	AJ3	1.1 A	0.93 A
PCE	12 A	ND(5.0) A	ND(5.0) A	AJ3	ND(0.50) A	0.25 A/J
TCE	ND(5.0) A	ND(5.0) A	ND(5.0) A	AJ3	0.43 A/J	0.50 A
Total VOCs						0.58 A

MW-20-05-180	03/24/92	05/05/92	06/05/92
Carbon Tet	ND(5.0) A	ND(5.0) A	ND(5.0) A
PCE	ND(5.0) A	ND(5.0) A	ND(5.0) A
TCE	ND(5.0) A	ND(5.0) A	ND(5.0) A

MW-20-04-180	03/23/92	05/05/92	06/05/92
Carbon Tet	ND(5.0) A	ND(5.0) A	ND(5.0) A
PCE	ND(5.0) A	ND(5.0) A	ND(5.0) A
TCE	ND(5.0) A	ND(5.0) A	ND(5.0) A

MW-8-24-180	04/22/92	06/02/92
Carbon Tet	ND(5.0) A	ND(5.0) A
PCE	ND(5.0) A	ND(5.0) A
TCE	ND(5.0) A	ND(5.0) A

MW-02-09-180	03/09/94
Carbon Tet	ND(0.50) A
PCE	ND(0.50) A
TCE	1.3 A
Total VOCs	2.47

MW-02-23-180	03/10/94
Carbon Tet	0.38 A/J
PCE	ND(0.50) A
TCE	1.3 A
Total VOCs	1.68

MW-14-03-180	03/17/92	05/06/92	06/08/92
Carbon Tet	ND(5.0) A	ND(5.0) A	ND(5.0) A
PCE	ND(5.0) A	ND(5.0) A	ND(5.0) A
TCE	ND(5.0) A	ND(5.0) A	ND(5.0) A

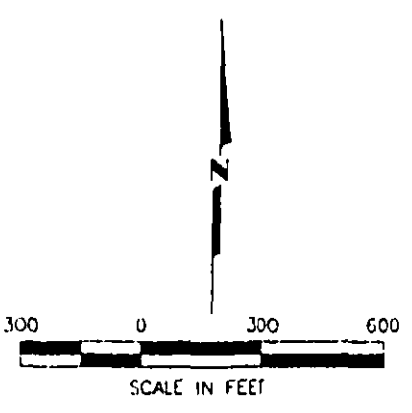

If this image is not as legible as this overlay, it's due to the poor quality of the original document

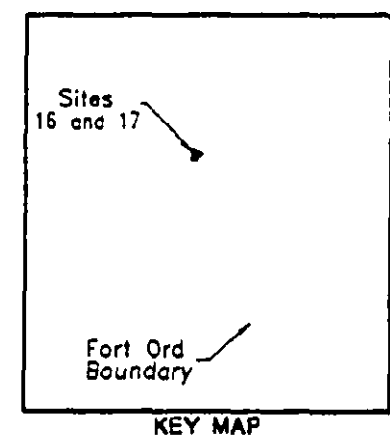

- NOTES:**
- CONTOURS REPRESENT CONCENTRATIONS OF TOTAL VOC'S DETECTED USING EPA METHOD 8010/8020 IN BOTH THE A-AQUIFER AND THE UPPER 180-FOOT AQUIFER AS MODIFIED FROM PLATE D6, VOLUME II - RI, BASEWIDE HYDROGEOLOGIC CHARACTERIZATION SECTION
 - THE CHEMICAL CONCENTRATION CONTOURS ARE BASED ON ONE INTERPRETATION OF THE DATA AVAILABLE WHEN THIS REPORT WAS PREPARED; OTHER INTERPRETATIONS MAY BE POSSIBLE.

SOIL BORING LOGS AND WELL CONSTRUCTION DETAILS

The appendix contains the soil boring logs for Sites 16 and 17. These borings were logged during drilling by HLA geologists or engineers using ASTM D 2488-90, which is based on the Unified Soil Classification System (USCS), the HLA Sampling and Analysis Plan (HLA, 1991b) and standard geologic techniques. Selected soil samples were submitted to either the HLA Soil Laboratory (Phase 1) or SOLEA geotechnical laboratory (Phase 2) in Concord, California, for physical testing summarized in Table 9; Appendix C contains the results of these analyses. SOLEA also visually classified these soil samples using the USCS.

Variations have been observed among the field and laboratory classifications of some of the soil samples. This is a result of the natural descriptive variation among individuals performing the classifications. For example, most of the soil at Fort Ord is composed of fine- to medium-grained sand. The fines content (silt- and clay-sized particles that pass the U.S. Standard No. 200 sieve) generally varies from 0 to 25 percent, with many soil samples containing 3 to 15 percent fines. Visual or manual classification of these fines as silt, clay, or a mixture of both can be subjective. In addition, the 3 to 15 percent fines content covers a range of up to nine different soil classifications; in this range, the material composition and hydraulic behavior may vary little. Quantitative assessment of the silt and clay percentages requires the use of other tests, such as the hydrometer test, which were outside the scope of work.

Because of the descriptive variation, a field log may describe a soil sample as sand to silty sand, whereas the sieve analysis for that same sample results in classification as sand to clayey sand. This does not mean that one classification is erroneous; rather, it suggests that the fines content is probably a variable mixture of clay and silt. It is important to note that when the hydraulic behavior of a particular material becomes important, its behavior is defined by aquifer testing as well as visual classification.

Such aquifer tests are representative of a larger volume of soil than are laboratory or field classification of individual samples. For the Fort Ord reports, the particle size analyses are used to quantify the percentage of fines. In some borderline cases, the field classification has been changed to take the actual fines content into account. In general, the text discusses the classification drawn from the field logs.

Some variations in the soil classification abbreviations between boring logs and the particle size analyses are the result of a small difference between the USCS and ASTM D 2488-90. The ASTM method, used by the field geologists and engineers, classifies sand with more than 15 percent fines as silty or clayey sand. The USCS method, used by the geotechnical laboratory, uses 12 percent fines content as the threshold. The boring logs and the text use the ASTM method.

Density descriptions for sand and gravel and consistency descriptions for clay and silt are drawn from the sample hammer blow counts, if available. For soil intervals that were not sampled, field personnel made quantitative estimates on the basis of drilling rate or pressure; descriptions should not be converted to quantitative measurements.

MAJOR DIVISIONS			SYMBOLS	TYPICAL NAMES
COARSE-GRAINED SOILS OVER 50% > No. 200 SIEVE SIZE	GRAVELS MORE THAN 1/2 OF COARSE FRACTION > No. 4 SIEVE SIZE	CLEAN GRAVELS WITH LESS THAN 5% FINES	GW	Well-graded gravels or gravel-sand mixtures, little or no fines
			GP	Poorly graded gravels or gravel-sand mixtures, little or no fines
		GRAVELS WITH OVER 15% FINES	GM	Silty gravels, gravel-sand mixtures
			GC	Clayey gravels, gravel-sand-clay mixtures
	SANDS MORE THAN 1/2 OF COARSE FRACTION < No. 4 SIEVE SIZE	CLEAN SANDS WITH LESS THAN 5% FINES	SW	Well-graded sands or gravelly sands, little or no fines
			SP	Poorly graded sands or gravelly sands, little or no fines
		SANDS WITH OVER 15% FINES	SM	Silty sands, sand-silt mixtures
			SC	Clayey sands, sand-clay mixtures
FINE-GRAINED SOILS OVER 50% < No. 200 SIEVE SIZE	SILTS & CLAYS LIQUID LIMIT 50% OR LESS	ML	Inorganic silts and very fine sands, rock flour, silty or clayey fine sands or clayey silts with slight plasticity	
		CL	Inorganic clays of low to medium plasticity, gravelly clays, sandy clays, silty clays, lean clays	
		OL	Organic silts and organic silty clays of low plasticity	
	SILTS & CLAYS LIQUID LIMIT GREATER THAN 50%	MH	Inorganic silts, micaceous or diatomaceous fine sandy or silty soils, elastic silts	
		CH	Inorganic clays of high plasticity, fat clays	
		OH	Organic clays of medium to high plasticity, organic silty clays, organic silts	
HIGHLY ORGANIC SOILS			PT	Peat and other highly organic soils
DEBRIS ZONE ¹				Metal, concrete, plastic, brick, wood, etc.
CONSTRUCTION DEBRIS ¹				Concrete, wood, rebar, asphalt

SYMBOLS KEY

	Bulk or classification sample
	Sample preserved for possible laboratory analysis
	Hydropunch sample
	First-encountered groundwater level
	Static groundwater level
(10YR 4/4)	Munsell soil color 1990 edition
NA	Not available
ND	Not detected

GRAIN SIZE CHART

CLASSIFICATION	RANGE OF GRAIN SIZES	
	U.S. Standard Sieve Size	Grain Size in Millimeters
BOULDERS	Above 12"	Above 305
COBBLES	12" to 3"	305 to 76.2
GRAVEL coarse fine	3" to No. 4	76.2 to 4.75
	3" to 3/4"	76.2 to 19.1
	3/4" to No. 4	19.1 to 4.75
SAND coarse medium fine	No. 4 to No. 200	4.75 to 0.075
	No. 4 to No. 10	4.75 to 2.00
	No. 10 to No. 40	2.00 to 0.425
	No. 40 to No. 200	0.425 to 0.075
SILT & CLAY	Below No. 200	Below 0.075

Source: ASTM D 2488-90, based on Unified Soil Classification System
 1. Not part of ASTM Classification System

FTO-LEG



Harding Lawson Associates
 Engineering and
 Environmental Services

Soil Classification Chart
 Volume II-RI, Basewide RI/FS
 Fort Ord, California

A 1

DRAWN JOB NUMBER
 CEG 23366 041711

APPROVED
RFM

DATE
 07/94

REVISED DATE

PLATE

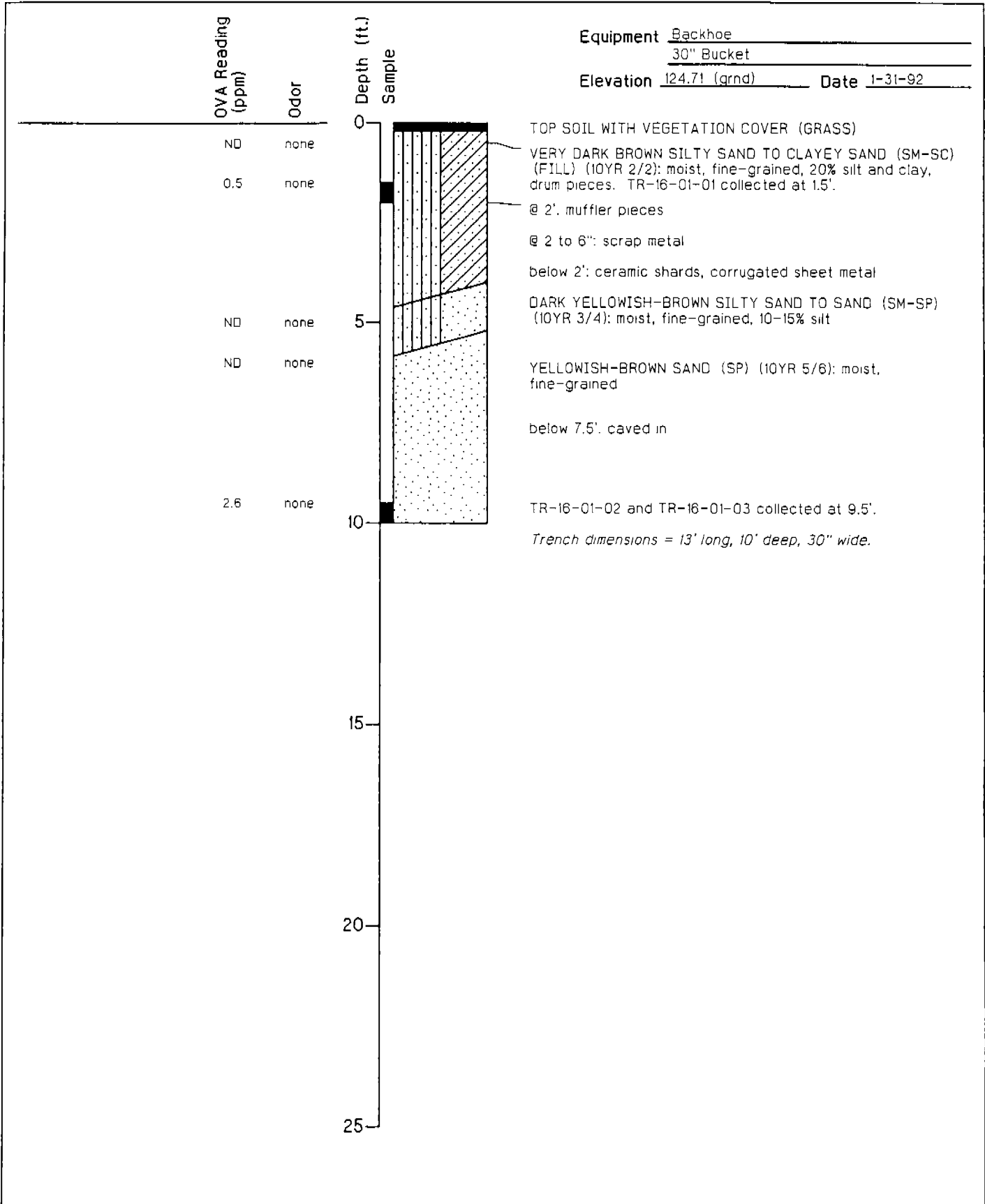

Equipment Backhoe
30" Bucket
 Elevation 124.71 (grnd) Date 1-31-92



Harding Lawson Associates
 Engineering and
 Environmental Services

Log of Trench TR-16-01
 Site Characterization
 Site 16 - DOL Maintenance Yard, Pete's Pond
 Fort Ord, California

PLATE

A2

DRAWN	JOB NUMBER	APPROVED	DATE	REVISED DATE
LRH	23366 041711	<i>ELH</i>	12/92	

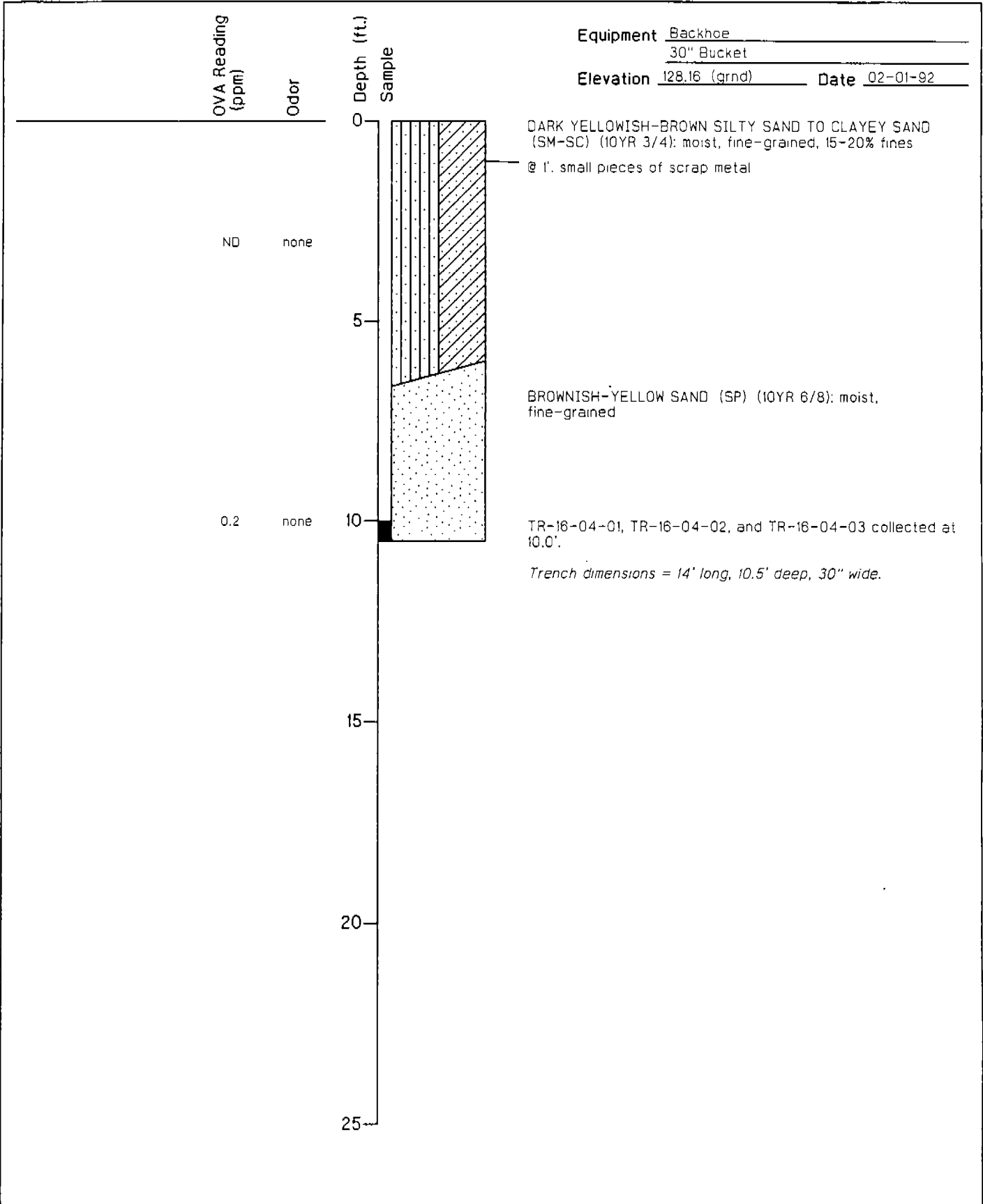

Harding Lawson Associates
 Engineering and
 Environmental Services

Log of Trench TR-16-04
 Site Characterization
 Site 16 - DOL Maintenance Yard, Pete's Pond
 Fort Ord, California

PLATE

A4

DRAWN: LRH
 JOB NUMBER: 23366 041711

APPROVED: *[Signature]*

DATE: 12/92

REVISED DATE:

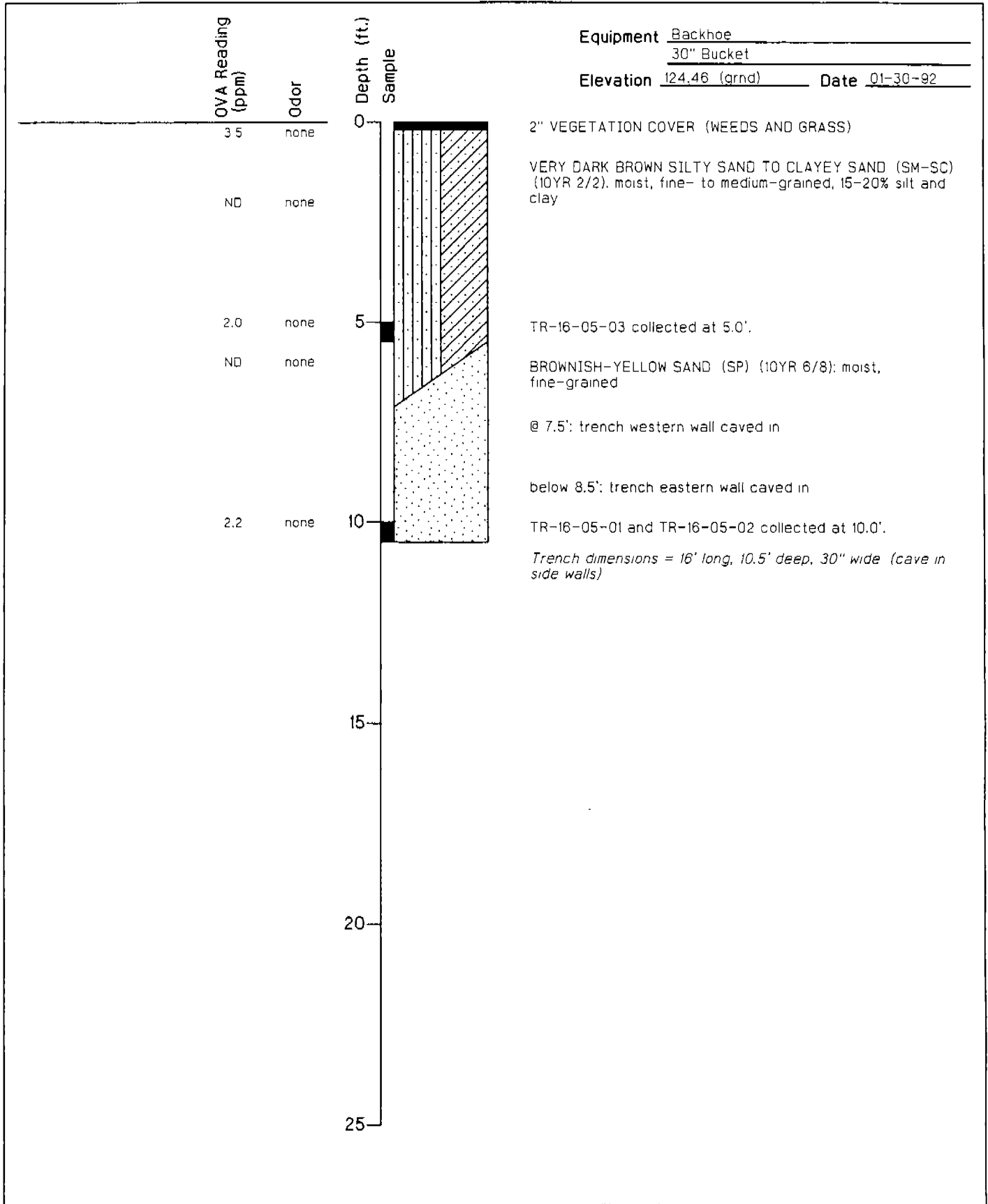

Equipment Backhoe
30" Bucket
 Elevation 124.46 (grnd) Date 01-30-92



Harding Lawson Associates
 Engineering and
 Environmental Services

Log of Trench TR-16-05
 Site Characterization
 Site 16 - DOL Maintenance Yard, Pete's Pond
 Fort Ord, California

PLATE

A5

DRAWN LRH	JOB NUMBER 23366 041711	APPROVED <i>E. J.</i>	DATE 12/92	REVISED DATE
--------------	----------------------------	--------------------------	---------------	--------------

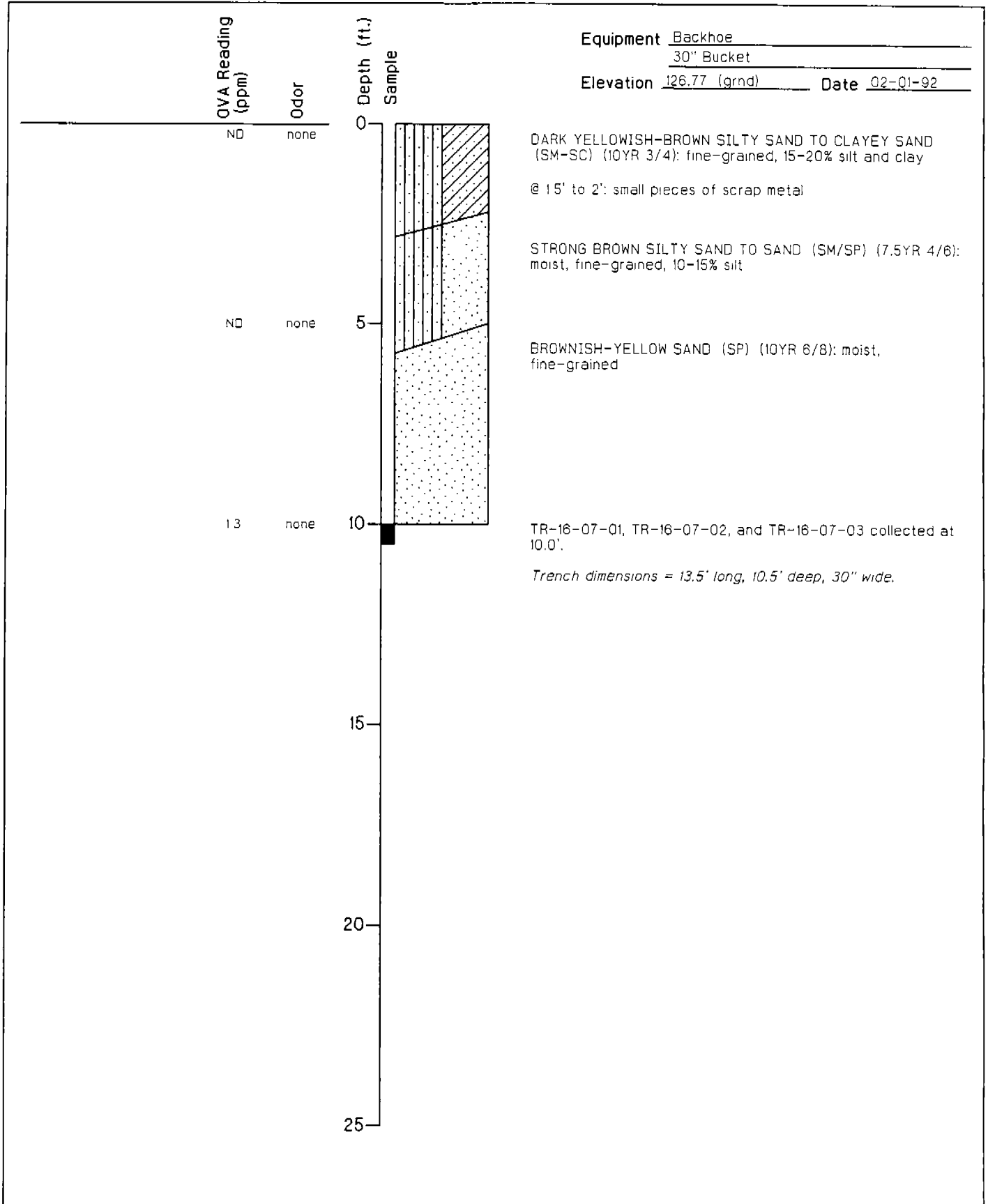

Harding Lawson Associates
Engineering and
Environmental Services

Log of Trench TR-16-07
Site Characterization
Site 16 - DOL Maintenance Yard, Pete's Pond
Fort Ord, California

PLATE

A7

DRAWN LRH
JOB NUMBER 23366 041711

APPROVED
[Signature]

DATE 12/92

REVISED DATE

Test Pit #: TR-16-08
 Date Started: 8-16-93
 Date Completed: 8-16-93
 Orientation: N40E
 Elevation:

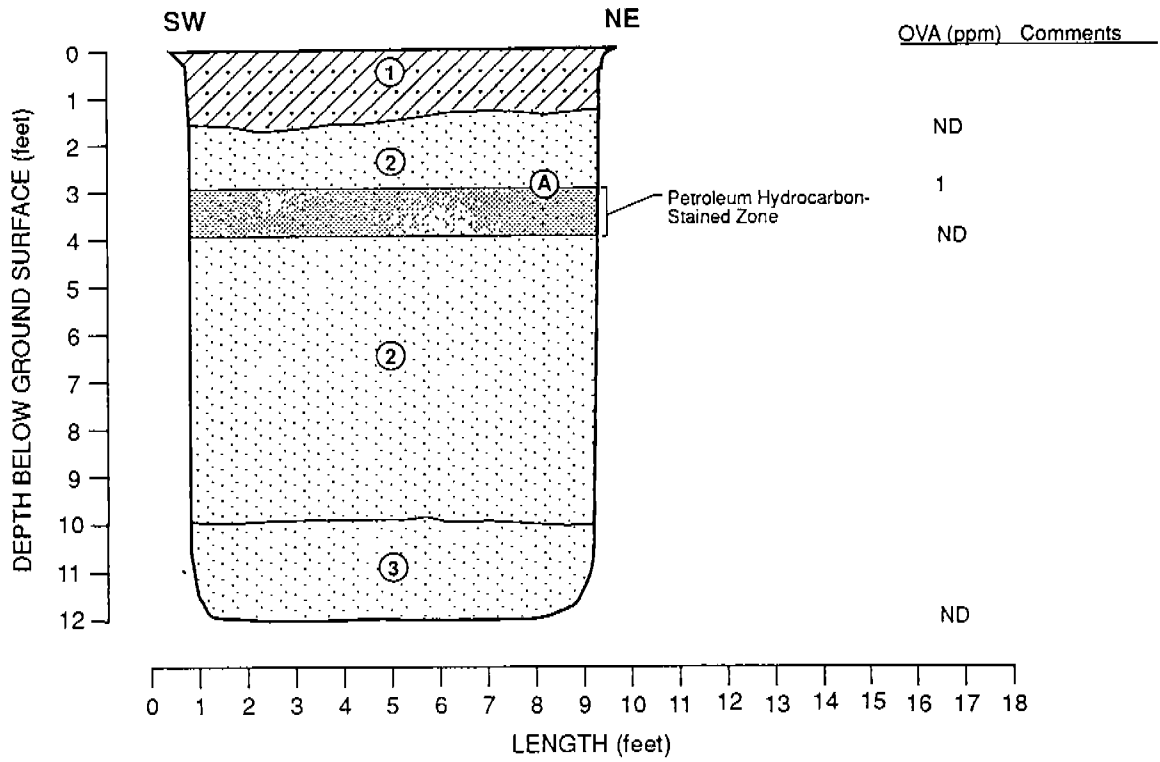

EXPLANATION:

- ① GRAYISH BROWN CLAYEY SAND WITH GRAVEL (SC) dense, dry fine to medium sand, 25% clay, 20% fine to coarse subrounded gravel, fill
- ② DARK BROWN SAND (SP) medium dense, moist, fine sand, 10% silt
Color change to black (2.5Y 2.5/1) between 3 and 4 feet
- ③ LIGHT YELLOWISH BROWN SAND (SP) medium dense, moist, fine sand, 10% silt

Ⓐ SAMPLE: 9333B016004F

070694AG



Harding Lawson Associates
 Engineering and
 Environmental Services

Log of Test Pit TR-16-08
 Site 16-DOL Maintenance Yard
 Volume II - RI, Basewide RI/FS
 Fort Ord, California

PLATE

A8

DRAWN DJPC	JOB NUMBER 23366 041711	APPROVED <i>RFM</i>	DATE 10/93	REVISED DATE
---------------	----------------------------	------------------------	---------------	--------------

Test Pit #: TR-16-09
 Date Started: 8-16-93
 Date Completed: 8-16-93
 Orientation: N21W
 Elevation:

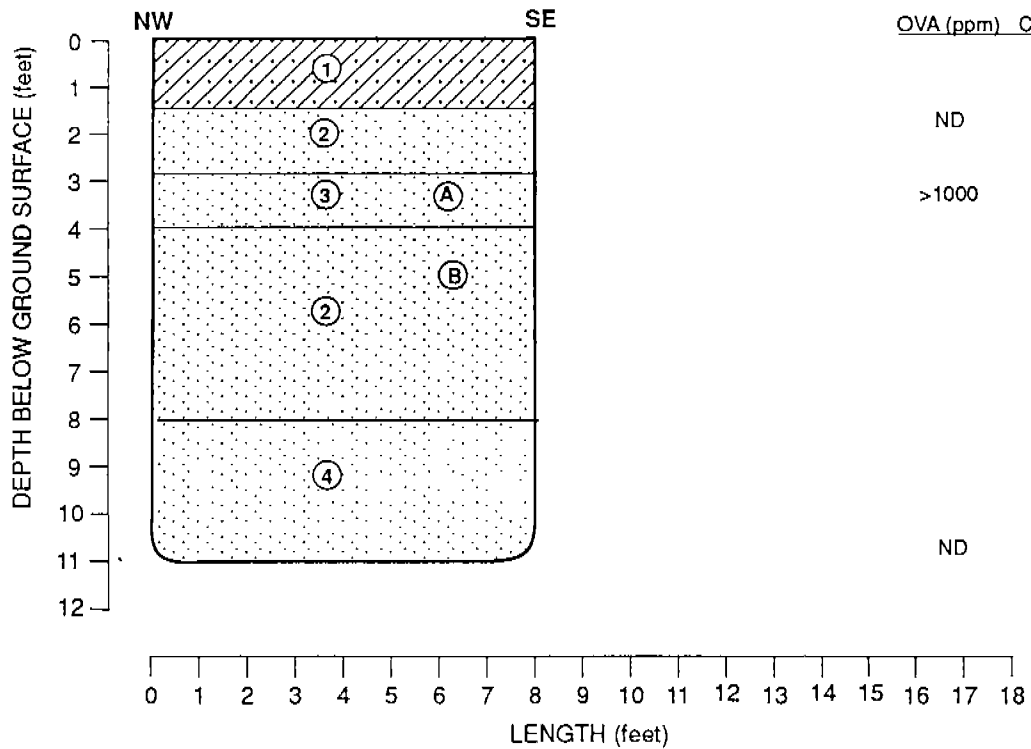

EXPLANATION:



GRAYISH BROWN CLAYEY SAND WITH GRAVEL (SC) (2.5Y 3/2)
 dense, dry, fine to medium sand, 25% clay,
 20% fine to coarse subrounded gravels, concrete chips, fill



DARK BROWN SAND (SP) (7.5YR 3/3)
 medium dense, moist, fine sand, 10% silt



VERY DARK GRAY SAND (SP) (7.5YR 3/1)
 medium dense, dry, fine sand, 10% silt



LIGHT YELLOWISH BROWN SAND (SP) (10YR 6/4)
 medium dense, moist, fine sand, 10% silt



SAMPLE: 9333B016005F



SAMPLE: 9333B016011F

070694AG



Harding Lawson Associates

Engineering and
 Environmental Services

Log of Test Pit TR-16-09

Site 16-DOL Maintenance Yard
 Volume II - RI, Basewide RI/FS
 Fort Ord, California

PLATE

A9

DRAWN: DJPc
 JOB NUMBER: 23366 041711

APPROVED: *RFA*

DATE: 10/93

REVISED DATE

Test Pit #: TR-16-10
 Date Started: 8-16-93
 Date Completed: 8-16-93
 Orientation: N50W
 Elevation:

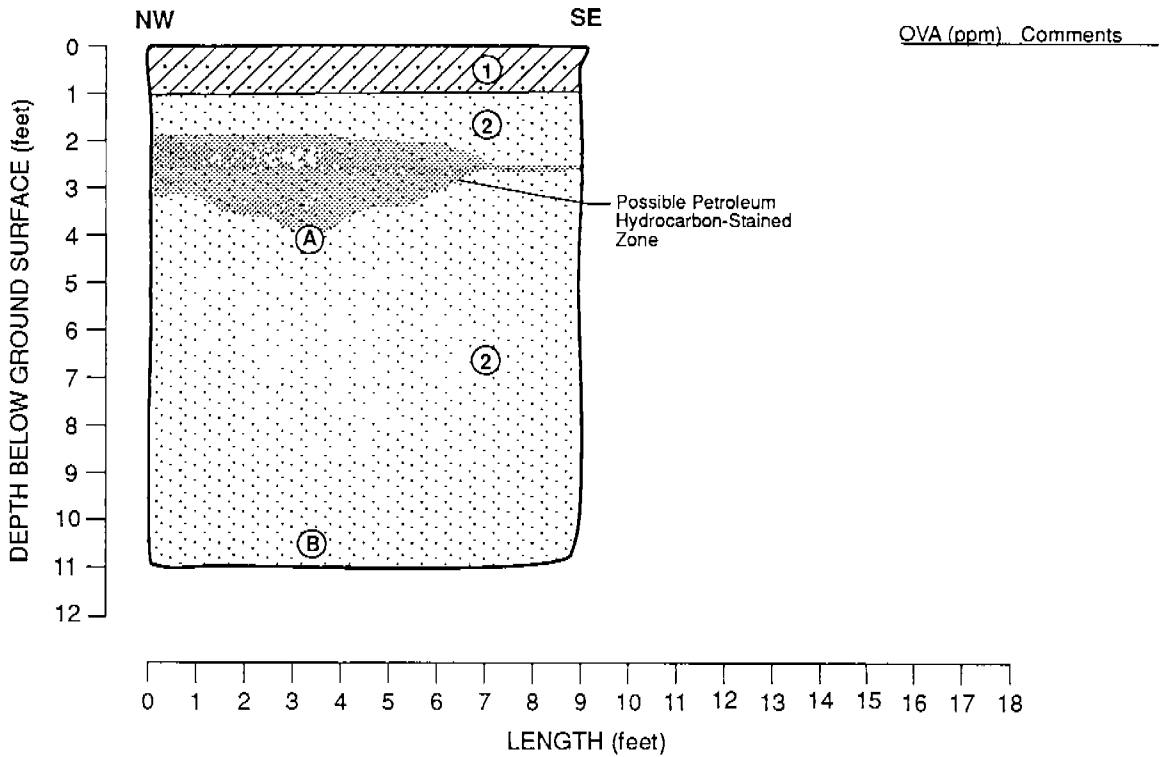

EXPLANATION:



GRAYISH BROWN CLAYEY SAND WITH GRAVEL (SC) (2.5Y 5/2), dense, dry, fine to medium sand, 25% clay, 20% fine to coarse gravel, fill



DARK BROWN SAND (SP) (7.5YR 3/3), medium dense, moist, fine sand, 10% silt, 5% roots between 1 and 2 feet depth
 Color change to very dark gray (2.5YR 3/1) between 2 and 4 feet



SAMPLE: 9333B016009F



SAMPLE: 9333B016010F

070694AG



Harding Lawson Associates
 Engineering and
 Environmental Services

Log of Test Pit TR-16-10
 Site 16-DOL Maintenance Yard
 Volume II - RI, Basewide RI/FS
 Fort Ord, California

PLATE

A10

DRAWN
 DJPc

JOB NUMBER
 23366 041711

APPROVED

DATE
 10/93

REVISED DATE

Test Pit #: TR-16-11
 Date Started: 8-16-93
 Date Completed: 8-17-93
 Orientation: N02W
 Elevation:

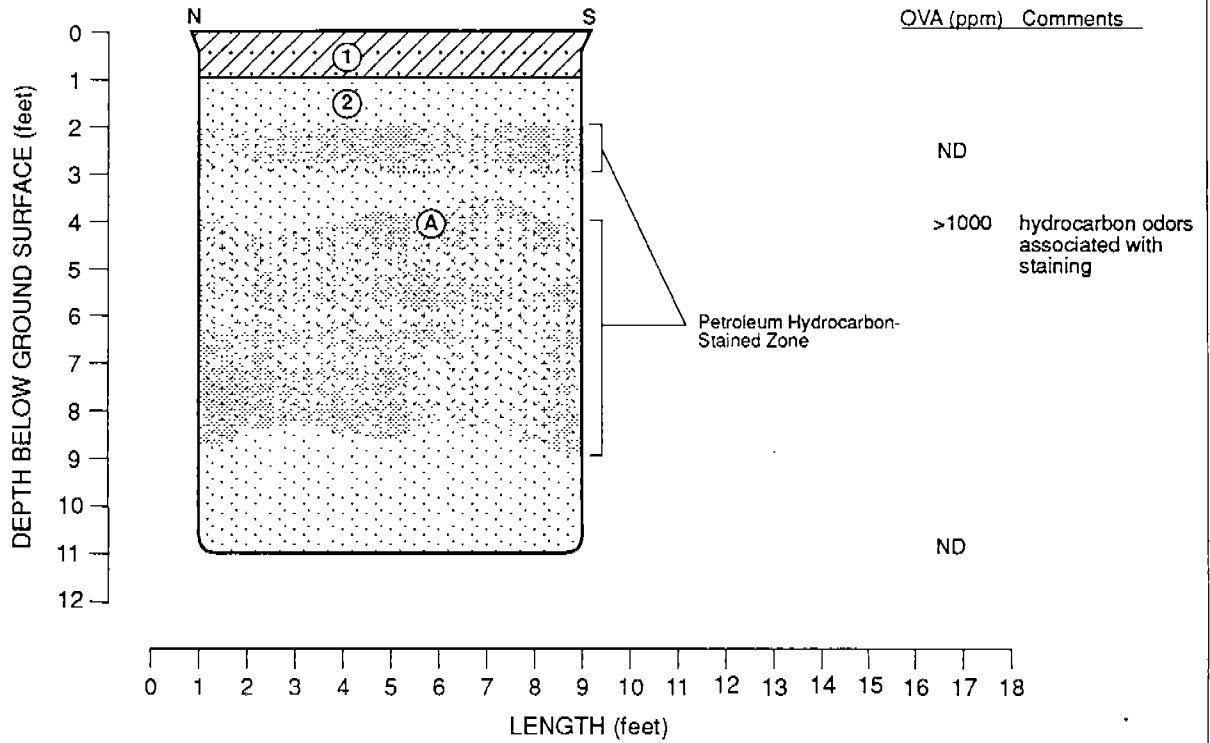

EXPLANATION:



GRAYISH BROWN CLAYEY SAND WITH GRAVEL (SC) (2.5Y 5/2), dense, dry, fine to medium sand, 25% clay, 20% fine to coarse subrounded gravels and concrete fragments, fill



DARK BROWN SAND (SP) (7.5YR 3/3), medium dense, moist, fine sand, 10% silt
 Color change to very dark gray (2.5YR 3/1) between 2 and 3 feet and 4 and 9 feet



SAMPLE: 9333B016013F

070694AG

PLATE



Harding Lawson Associates

Engineering and
 Environmental Services

Log of Test Pit TR-16-11

Site 16-DOL Maintenance Yard
 Volume II - RI, Basewide RI/FS
 Fort Ord, California

A11

DRAWN
 DJPc

JOB NUMBER
 23366 041711

APPROVED
RFA

DATE
 11/93

REVISED DATE

Test Pit #: TR-16-12
 Date Started: 8-17-93
 Date Completed: 8-17-93
 Orientation: N10E
 Elevation:

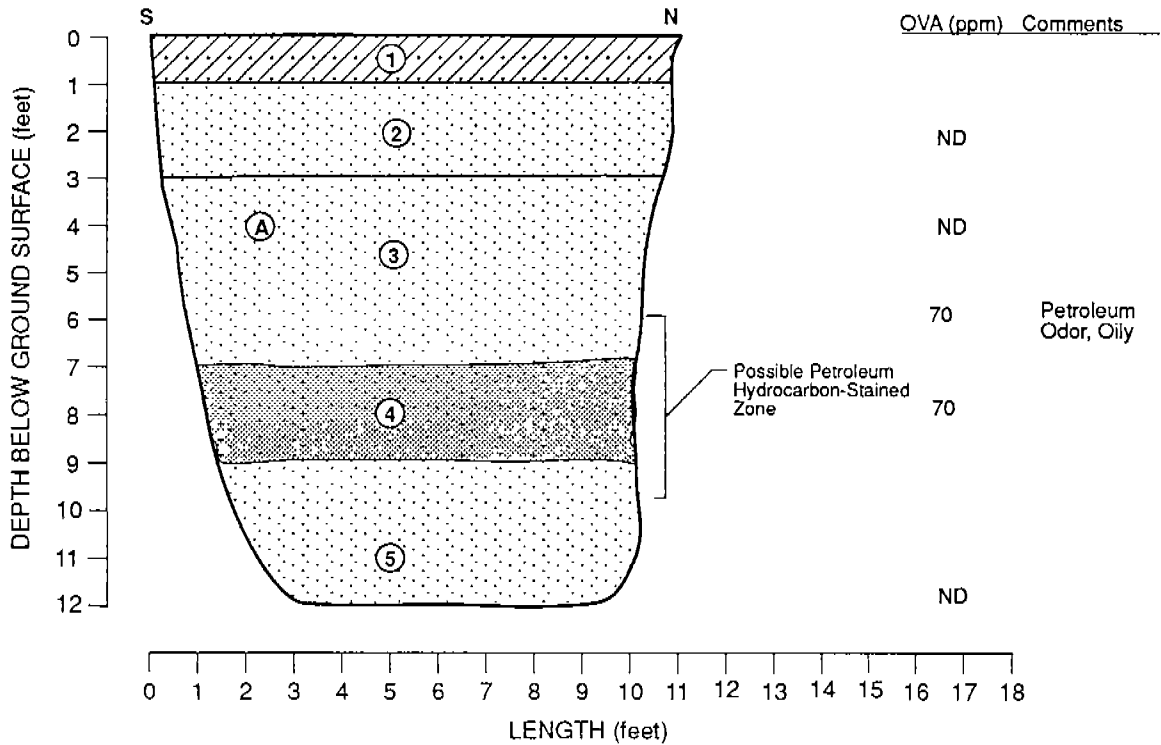

EXPLANATION:

- ① GRAYISH BROWN CLAYEY SAND WITH GRAVEL (SC) (2.5Y 5/2), dense, dry, fine to medium sand, 25% clay, 20% fine to coarse subrounded gravel, fill
 - ② YELLOWISH BROWN SAND (SP) (10YR 5/6), medium dense, dry, fine sand, 5% silt
 - ③ DARK YELLOWISH BROWN SAND (SP) (10YR 3/4), medium dense, moist, fine sand, 5% silt
 - ④ BLACK SAND (SP) (10YR), medium dense, dry to moist, fine sand, 5% silt, possibly petroleum hydrocarbon stained
 - ⑤ YELLOWISH BROWN SAND (SP) (10YR 5/8), loose, dry to moist, fine sand, 5% silt
- Ⓐ SAMPLE: 9333B016016F

070694AG



Harding Lawson Associates
 Engineering and
 Environmental Services

Log of Test Pit TR-16-12
 Site 16-DOL Maintenance Yard
 Volume II - RI, Basewide RI/FS
 Fort Ord, California

PLATE

A12

DRAWN
DJPC

JOB NUMBER
23366 041711

APPROVED
RFM

DATE
10/93

REVISED DATE

Test Pit #: TR-16-13
 Date Started: 8-17-93
 Date Completed: 8-17-93
 Orientation: N25E
 Elevation:

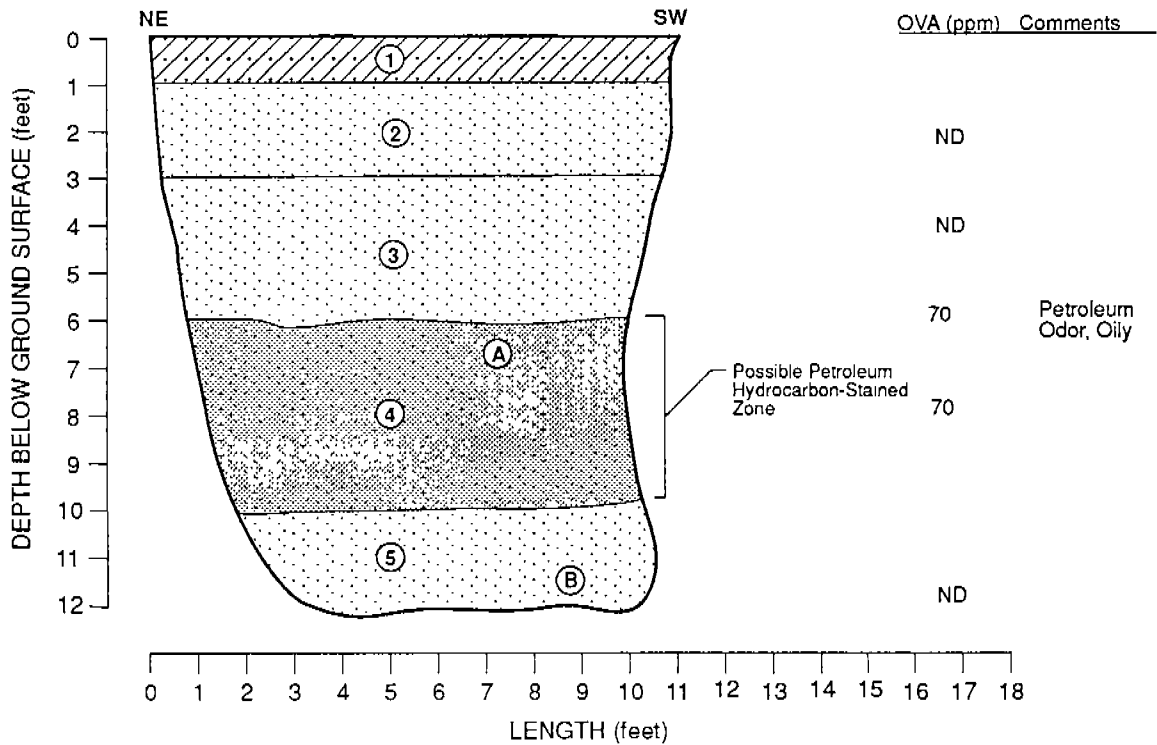

EXPLANATION:

- ① GRAYISH BROWN CLAYEY SAND WITH GRAVEL (SC) (2.5Y 5/2), dense, dry, fine to medium sand, 25% clay, 20% fine to coarse subrounded gravel and concrete fragments, fill
 - ② YELLOWISH BROWN SAND (SW) (10YR 5/6), loose, dry, fine sand, 10% silt
 - ③ DARK YELLOWISH BROWN SAND (SP) (10YR 3/4), medium dense, moist to dry, fine sand, 5% silt
 - ④ VERY DARK GREY SAND (SP) (10YR 3/1), loose, moist to wet, fine sand, 5% silt
 - ⑤ DARK YELLOWISH BROWN SAND (SP) (10YR 3/4), loose, dry to moist, fine sand, 5% silt
- Ⓐ SAMPLE: 9333B016020F
 Ⓑ SAMPLE: 9333B016021F

070694AG

PLATE



Harding Lawson Associates
 Engineering and
 Environmental Services

Log of Test Pit TR-16-13
 Site 16-DOL Maintenance Yard
 Volume II - RI, Basewide RI/FS
 Fort Ord, California

A13

DRAWN DJPC	JOB NUMBER 23366 041711	APPROVED RFM	DATE 10/93	REVISED DATE
---------------	----------------------------	-----------------	---------------	--------------

Test Pit #: TR-16-14
 Date Started: 8-17-93
 Date Completed: 8-18-93
 Orientation: N21E
 Elevation:

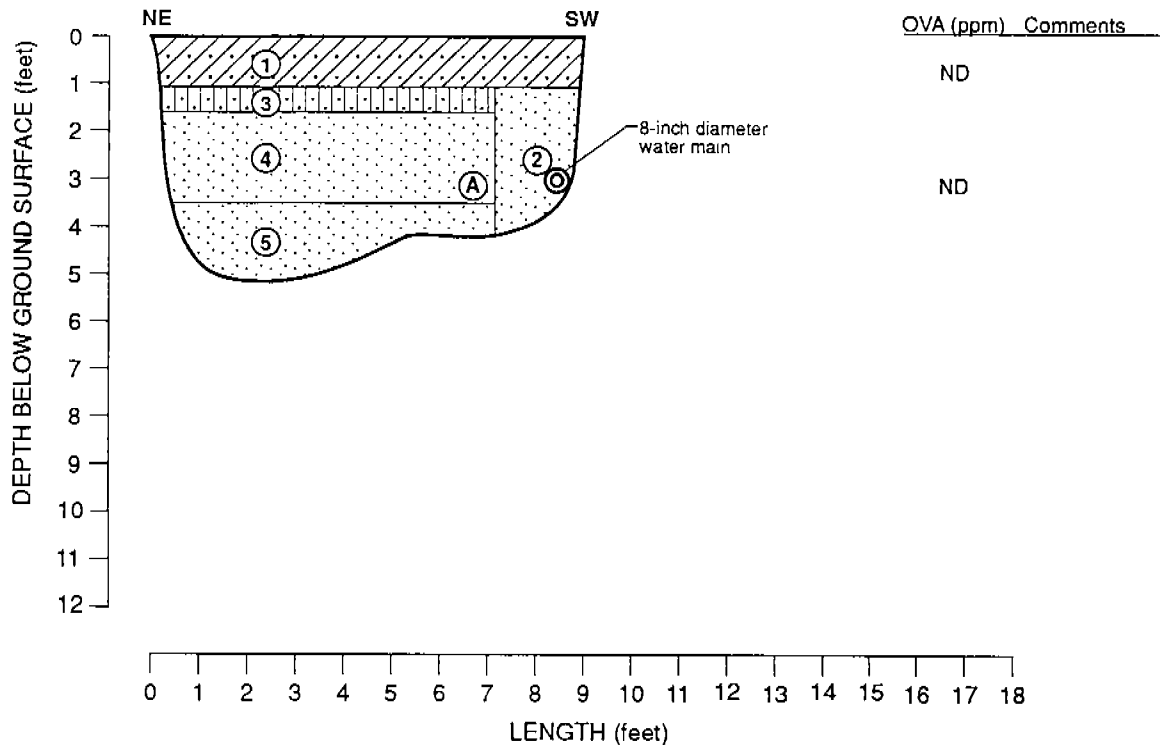

EXPLANATION:

- GRAYISH BROWN CLAYEY SAND WITH GRAVEL (SC) 2.5Y 5/2, dense, dry, fine to medium sand, 25% clay, 20% fine to coarse subrounded gravel, fill
- DARK YELLOWISH BROWN SAND (SP) (10YR 4/4), medium dense, moist, fine sand, 5% silt, backfill for water main
- VERY DARK GRAYISH BROWN SILTY SAND (SM) (10YR 3/2), dense, dry, fine sand, 20% silt
- YELLOWISH BROWN SAND (SP) (10YR 5/6), moist to dry, fine sand, 5% silt
- DARK YELLOWISH BROWN SAND (SP) (10YR 4/4), medium dense, moist, fine sand, 5% silt
- SAMPLE: 9333B016030F

070694AG



Harding Lawson Associates
 Engineering and
 Environmental Services

Log of Test Pit TR-16-14
 Site 16-DOL Maintenance Yard
 Volume II - RI, Basewide RI/FS
 Fort Ord, California

PLATE

A14

DRAWN	JOB NUMBER	APPROVED	DATE	REVISED DATE
DJPC	23366 041711	RFM	10/93	

Test Pit #: TR-16-15
 Date Started: 8-17-93
 Date Completed: 8-17-93
 Orientation: N70E
 Elevation:

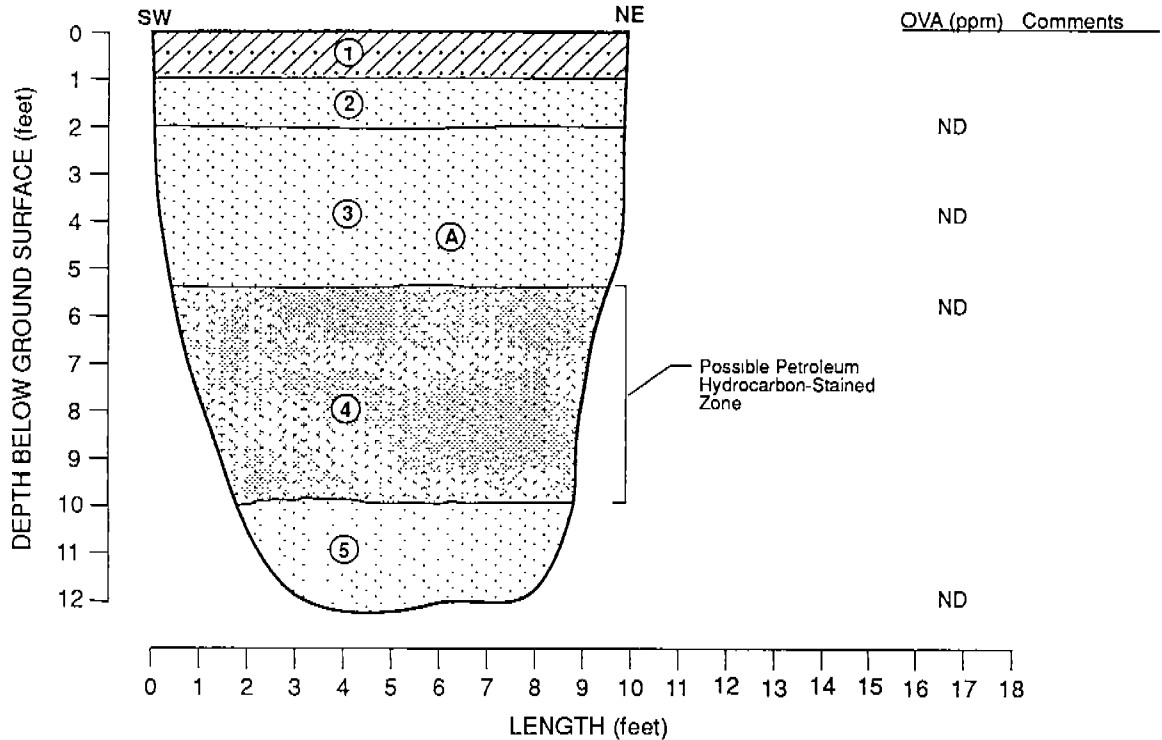

EXPLANATION:

- ① GRAYISH BROWN CLAYEY SAND WITH GRAVEL (SC) (2.5Y 5/2), dense, dry, fine to medium sand, 25% clay, 20% fine to coarse subrounded gravel, fill
 - ② YELLOWISH BROWN SAND (SP) (10YR 5/6), medium dense, moist to dry, fine sand, 10% silt
 - ③ DARK YELLOWISH BROWN SAND (SP) medium dense, moist to dry, fine sand, 5% silt
 - ④ VERY DARK GREY SAND (SP) (10YR 3/1), medium dense, dry to moist, fine sand, 5% silt
 - ⑤ YELLOWISH BROWN SAND (SP) (10YR 5/6), loose, dry, fine sand, 5% silt
- Ⓐ SAMPLE: 9333B016023F

070694AG

PLATE



Harding Lawson Associates
 Engineering and
 Environmental Services

Log of Test Pit TR-16-15
 Site 16-DOL Maintenance Yard
 Volume II - RI, Basewide RI/FS
 Fort Ord, California

A15

DRAWN	JOB NUMBER	APPROVED	DATE	REVISED DATE
DJPC	23366 041711	RFM	10/93	

Test Pit #: TR-16-16
 Date Started: 8-17-93
 Date Completed: 8-17-93
 Orientation: N22W
 Elevation:

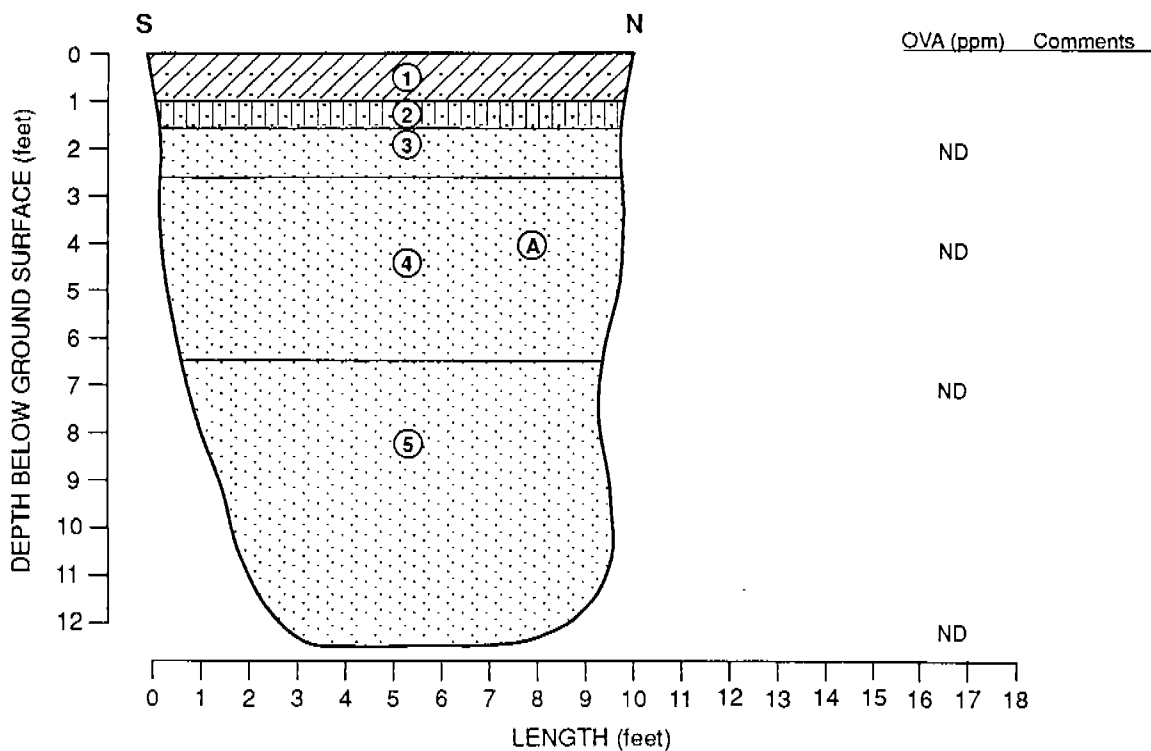

EXPLANATION:

- ① GRAYISH BROWN CLAYEY SAND WITH GRAVEL (SC) (2.5Y 5/2) dense, dry, fine to medium sand, 25% clay, 20% fine to coarse subrounded gravel, fill
- ② VERY DARK GRAYISH BROWN SILTY SAND (SM) 10YR 3/2 dense, dry, fine sand, 20% silt, fill
- ③ YELLOWISH BROWN SAND (SP) (10YR 5/6) loose, dry, fine sand, 10% silt
- ④ DARK YELLOWISH BROWN SAND (SP) (10YR 4/4) medium dense, moist to dry, fine sand, 5% silt, color varies
Color change to yellowish brown between 5 and 6.5 feet
- ⑤ VERY DARK GRAY SAND (SP) (10YR 3/1) medium dense, moist, fine sand, 5-10% silt, >5% roots, musty smell

Ⓐ SAMPLE: 9333B016027F

070694AG



Harding Lawson Associates
 Engineering and
 Environmental Services

Log of Test Pit TR-16-16
 Site 16-DOL Maintenance Yard
 Volume II - RI, Basewide RI/FS
 Fort Ord, California

PLATE

A16

DRAWN	JOB NUMBER	APPROVED	DATE	REVISED DATE
DJPC	23366 041711	RFM	11/93	

Test Pit #: TR-16-17
 Date Started: 8-18-93
 Date Completed: 8-18-93
 Orientation: N38E
 Elevation:

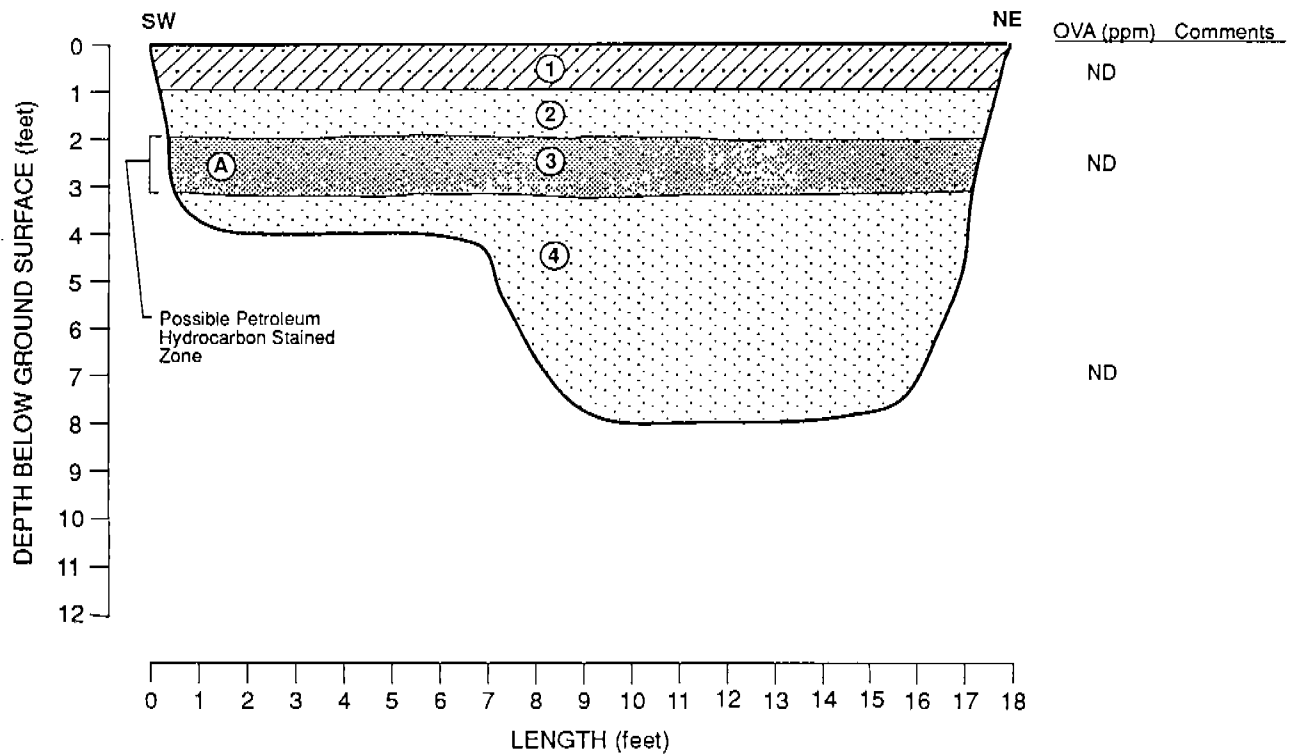

EXPLANATION:

- ① GRAYISH BROWN CLAYEY SAND WITH GRAVEL (SC) (2.5Y 5/2) dense, dry, fine to medium sand, 25% clay, 20% fine to coarse subrounded gravels and concrete fragments, fill
- ② YELLOWISH BROWN SAND (SP) (10YR 5/6) loose, dry, fine sand, 5% silt
- ③ VERY DARK GRAYISH BROWN SAND (SP) (10YR 3/2) medium dense, dry to moist, fine sand, 5% silt, apparent hydrocarbon staining
- ④ DARK YELLOWISH BROWN SAND (SP) (10YR 4/4) medium dense, dry to moist, fine sand, 5% silt

Ⓐ SAMPLE: 9333B016034F

070694AG

PLATE



Harding Lawson Associates
 Engineering and
 Environmental Services

Log of Test Pit TR-16-17
 Site 16—DOL Maintenance Yard
 Volume II - RI, Basewide RI/FS
 Fort Ord, California

A17

DRAWN: DJPc
 JOB NUMBER: 23366 041711

APPROVED: RFM

DATE: 10/93

REVISED DATE

Test Pit #: TR-16-18
 Date Started: 8-18-93
 Date Completed: 8-18-93
 Orientation: N45W
 Elevation:

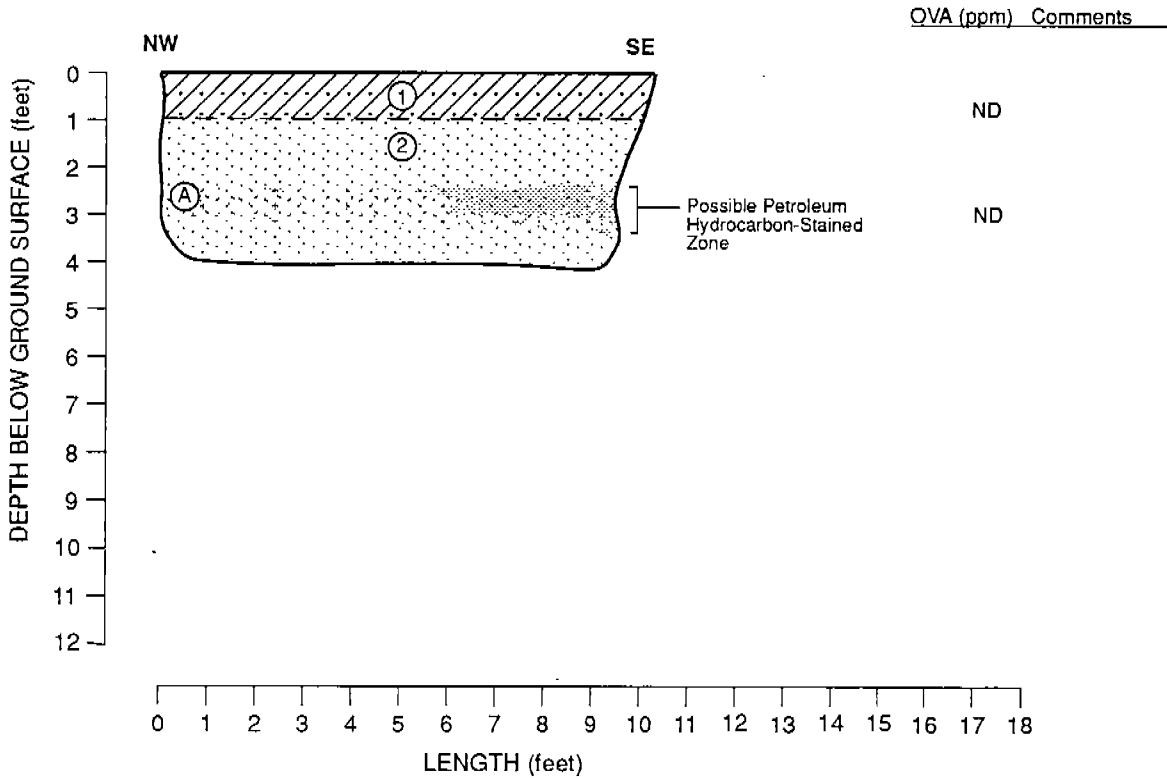

EXPLANATION:

- 
 GRAYISH BROWN CLAYEY SAND WITH GRAVEL (SC) (2.5Y 5/2)
 dense, dry, fine to medium sand, 25% clay,
 20% fine to coarse subrounded gravels, fill

- 
 DARK YELLOWISH BROWN SAND (SP) (10YR 3/6)
 loose, dry to moist, fine sand, 5% silt
 Color change to very dark brown (10YR 2/2) between 2.5 and
 3 feet, petroleum hydrocarbon staining

- 
 SAMPLE: 9333B016035F

070694AG



Harding Lawson Associates
 Engineering and
 Environmental Services

Log of Test Pit TR-16-18
 Site 16-DOL Maintenance Yard
 Volume II - RI, Basewide RI/FS
 Fort Ord, California

PLATE

A18

DRAWN DJPC	JOB NUMBER 23366 041711	APPROVED RFM	DATE 10/93	REVISED DATE
---------------	----------------------------	-----------------	---------------	--------------

Test Pit #: TR-16-19
 Date Started: 8-18-93
 Date Completed: 8-18-93
 Orientation: N05W
 Elevation:

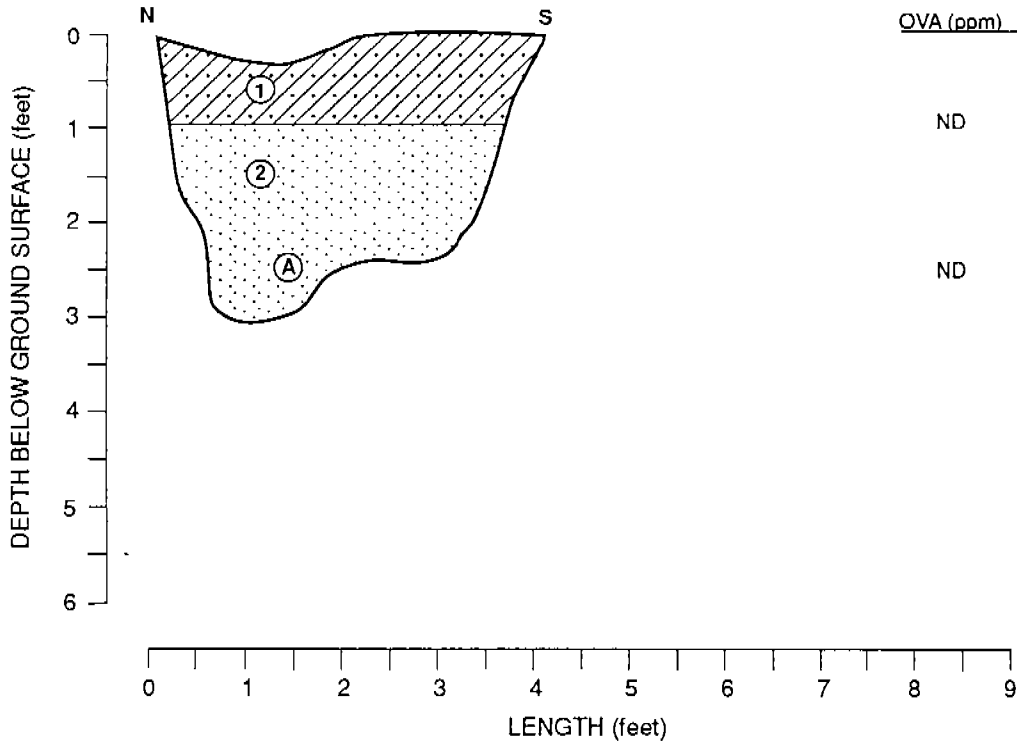

EXPLANATION:



DARK OLIVE BROWN CLAYEY SAND WITH GRAVEL (SC) (25Y 3/3) medium dense, moist, fine to medium sand, 25% clay, 20% fine to coarse gravel, fill



DARK YELLOWISH BROWN SAND (SP) loose, moist, fine sand, 5% silt
 Color change at 2 feet to mixed yellowish brown (10YR 5/6) and dark yellowish brown, swirls



SAMPLE: 9333B016036F

070694AG



Harding Lawson Associates
 Engineering and
 Environmental Services

Log of Test Pit TR-16-19
 Site 16-DOL Maintenance Yard
 Volume II - RI, Basewide RI/FS
 Fort Ord, California

PLATE

A19

DRAWN
 DJPc

JOB NUMBER
 23366 041711

APPROVED
RFM

DATE
 10/93

REVISED DATE

Test Pit #: TR-16-20
 Date Started: 8-16-93
 Date Completed: 8-18-93
 Orientation: N34W
 Elevation: 141 feet

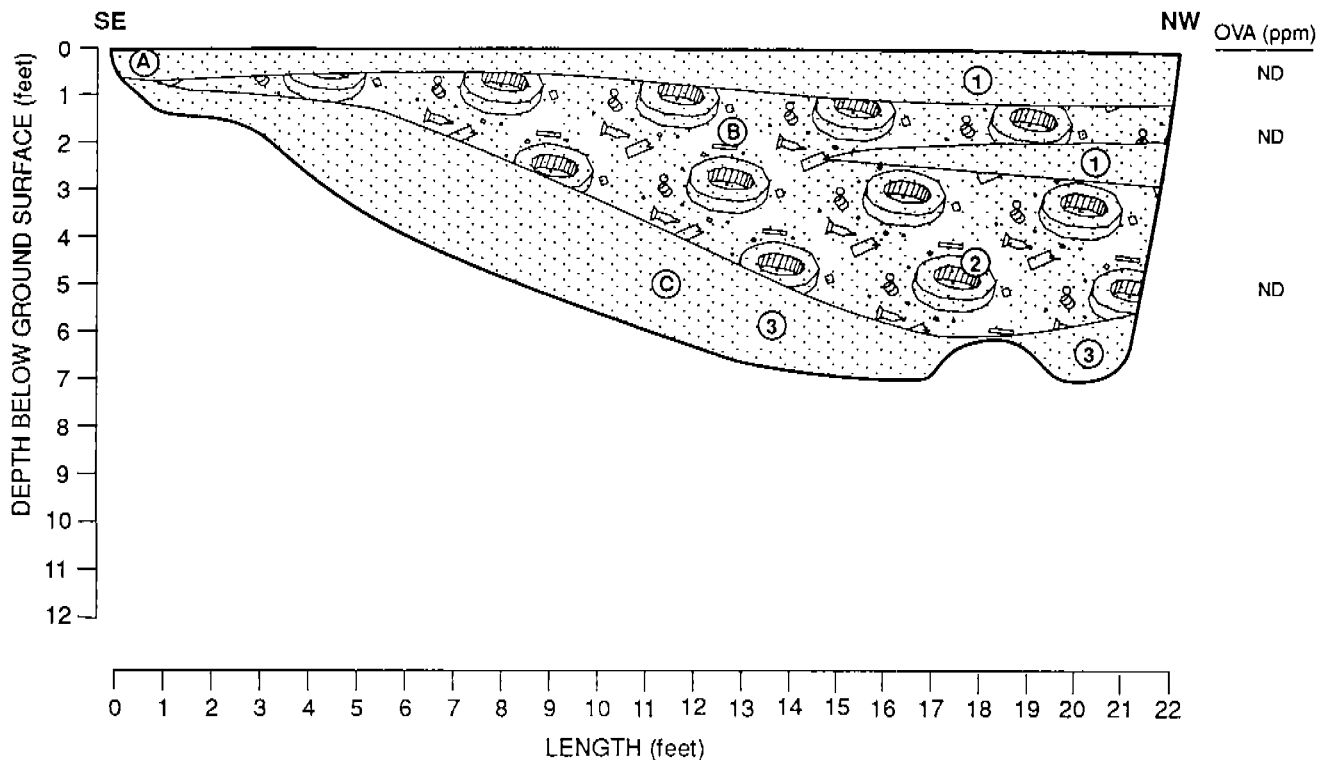

EXPLANATION:

- ① DARK BROWN SAND (SP) (10YR 3/3) very loose, dry, fine to medium sand, 5-10% silt, trace roots, fill
- ② LAMINATED BROWNISH YELLOW TO DARK YELLOWISH BROWN SAND (SP) (10YR 6/6 to 10 YR 3/4) very loose, dry, fine to medium sand, trace silt, 5-10% gravel (up to 1/4"), 10-20% debris (bazooka shell, 1945 shell casing, burnt wood, broken and melted glass [Delaware Punch bottle], metal pieces [can lids, nails, wire]), fill
- ③ DARK YELLOWISH BROWN SAND (SP) (10YR 4/4) loose, dry, fine to grained sand, trace silt, laminated with lighter colored layers of sand

- (A) SAMPLE: 9333A016038F
- (B) SAMPLE: 9333A016037F
- (C) SAMPLE: 9333A016039F

070694AG

PLATE



Harding Lawson Associates
 Engineering and
 Environmental Services

Log of Test Pit TR-16-20
 Site 16-Pete's Pond Extension
 Volume II - RI, Basewide RI/FS
 Fort Ord, California

A20

DRAWN
 DJPc

JOB NUMBER
 23366 041711

APPROVED
RFM

DATE
 10/93

REVISED DATE

Test Pit #: TR-16-21
 Date Started: 8-16-93
 Date Completed: 8-16-93
 Orientation: N36W
 Elevation: 141 feet

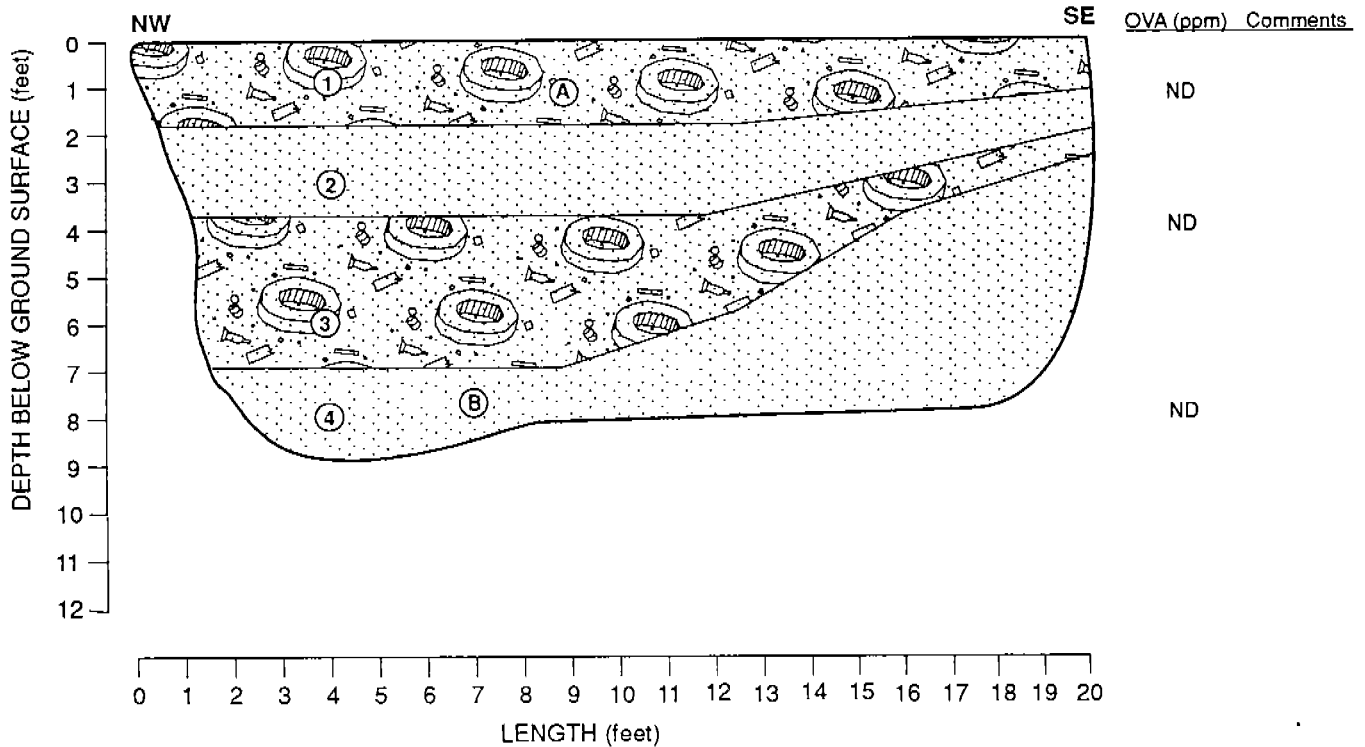

EXPLANATION:



PALE BROWN SAND (SP) (10YR 6/3), very loose, dry, fine to medium sand, 5-10% silt, 10-15% debris (primarily metal pieces and glass, trace charcoal), fill



PALE BROWN AND YELLOW BROWN SAND (SP) (10YR 6/3&10YR 5/8), very loose, dry, fine to medium sand, trace silt, trace debris, stratified, fill



BROWN SAND (SP) (10YR 4/3), very loose, dry, fine to medium sand, 5% silt, 25% debris (ammunition crate/foot locker, glass [i.e., 1952 soda bottle], metal pieces), fill



DARK YELLOWISH BROWN SAND (SP) (10YR 3/6), loose, dry, fine to medium-grained sand, 5-10% silt



SAMPLE: 9333A016033F



SAMPLE: 9333A016031F

070694AG

PLATE



Harding Lawson Associates

Engineering and
Environmental Services

Log of Test Pit TR-16-21

Site 16-Pete's Pond Extension
Volume II - RI, Basewide RI/FS
Fort Ord, California

A21

DRAWN
DJPC

JOB NUMBER
23366 041711

APPROVED
RFM

DATE
11/93

REVISED DATE

Test Pit #: TR-16-22
 Date Started: 8-17-93
 Date Completed: 8-17-93
 Orientation: N 40W
 Elevation: 151 feet at SE end

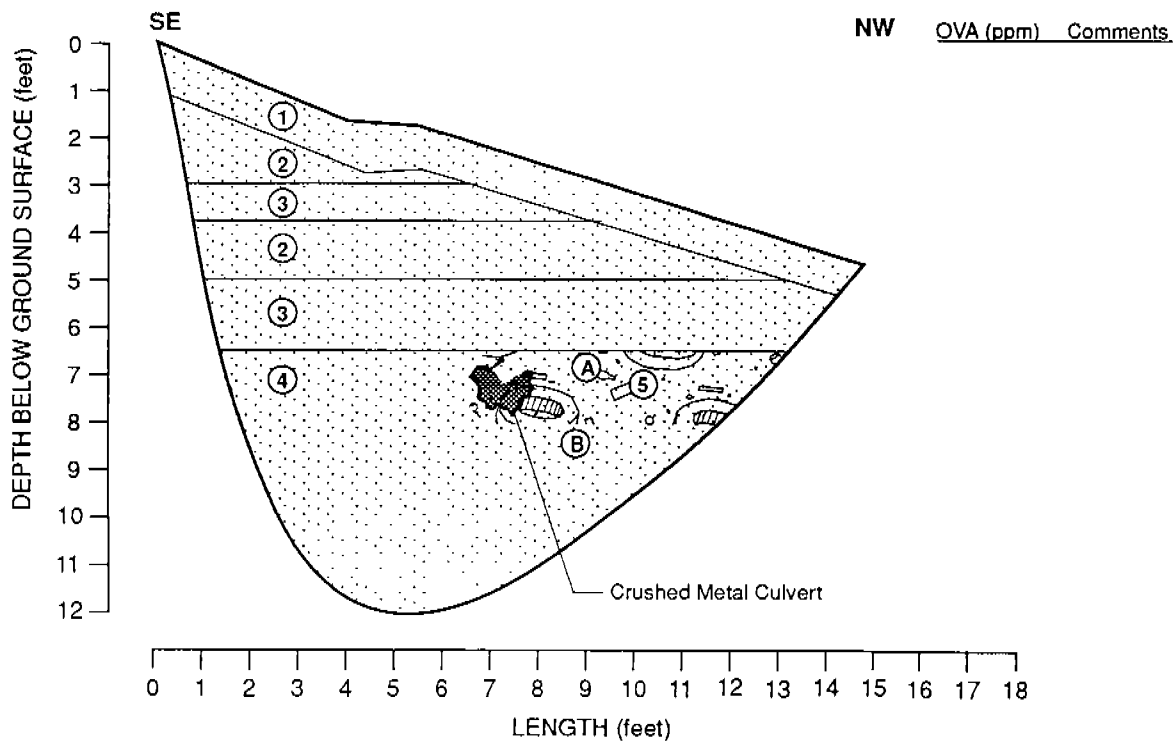

EXPLANATION:

- ① PALE BROWN SAND (SP) (10YR 6/3)
very loose, dry fine to medium sand, 5-10% silt, trace roots, fill
- ② VERY DARK GREYISH BROWN SAND (SP) (10YR 3/2) loose, dry, fine to medium sand, 10-15% silt, fill
- ③ DARK YELLOW BROWN SAND (SP) (10YR 4/4) loose, dry, fine to medium sand, 5-10% silt, trace roots, fill
- ④ VERY DARK GREYISH BROWN SAND (SP) (10YR 3/2) loose, dry, fine to medium sand, 10-15% silt, trace roots, fill
- ⑤ DEBRIS LAYER including scrap metal, glass, ceramic culvert pieces, melted glass, burnt wood, shell casing (1944), wires, metal cup
- Ⓐ SAMPLE: 9333C016004F
- Ⓑ SAMPLE: 9333C016005F

070694AG



Harding Lawson Associates
 Engineering and Environmental Services

Log of Test Pit TR-16-22
 Site 16-Pete's Pond Extension
 Volume II - RI, Basewide RI/FS
 Fort Ord, California

PLATE

A22

DRAWN	JOB NUMBER	APPROVED	DATE	REVISED DATE
DJPC	23366 041711	<i>RFM</i>	10/93	

Test Pit #: TR-16-23
 Date Started: 8-17-93
 Date Completed: 8-17-93
 Orientation: N40E
 Elevation: 145 feet at SE end

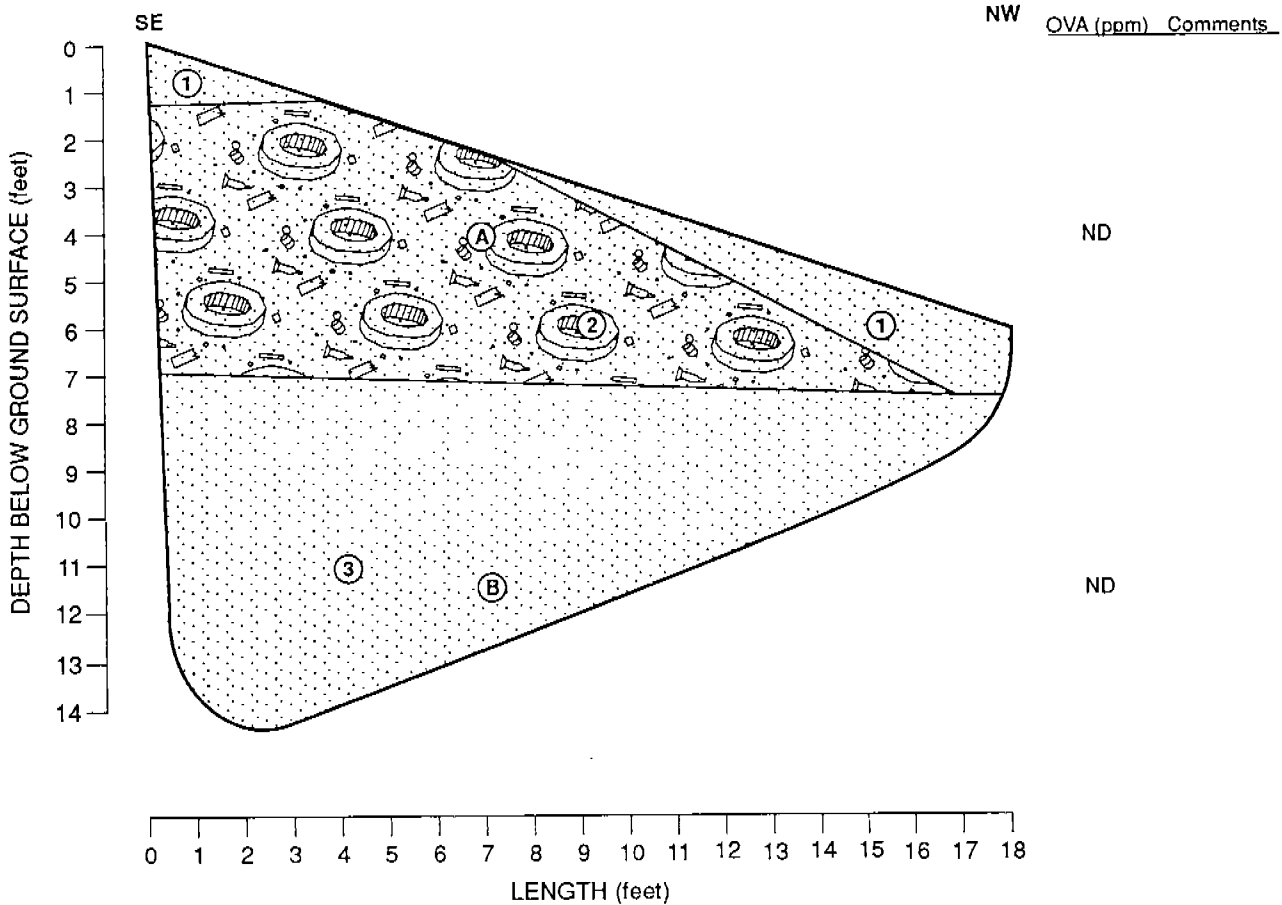

- EXPLANATION:**
- ① BROWN SAND (SP) (10YR 4/3), very loose, dry, fine to medium sand, 5-15% silt, trace plant roots, fill
 - ② DARK BROWN SAND (SP) (10YR 3/3), very loose, dry, fine to medium sand, trace gravel (up to 1/4" diameter), trace silt, 5-25% debris (mostly rusted metal, metal cans, cot frame, leaf spring, window regulator, 1" pipe section [2' long], engine flywheel, both whole and broken glass jars and bottles, melted shampoo jar, medical jars), fill
 - ③ DARK YELLOWISH BROWN SAND (SP) (10YR 3/4), loose, dry, fine to medium sand, trace silt
- Ⓐ SAMPLE: 9333C016007F
 Ⓑ SAMPLE: 9333C016006F

070649AG



Harding Lawson Associates
 Engineering and
 Environmental Services

Log of Test Pit TR-16-23
 Site 16-Pete's Pond Extension
 Volume II - RI, Basewide RI/FS
 Fort Ord, California

PLATE

A23

DRAWN	JOB NUMBER	APPROVED	DATE	REVISED DATE
DJPC	23366 041711	RFM	10/93	

Test Pit #: TR-16-24
 Date Started: 8-17-93
 Date Completed: 8-17-93
 Orientation: N47W
 Elevation:

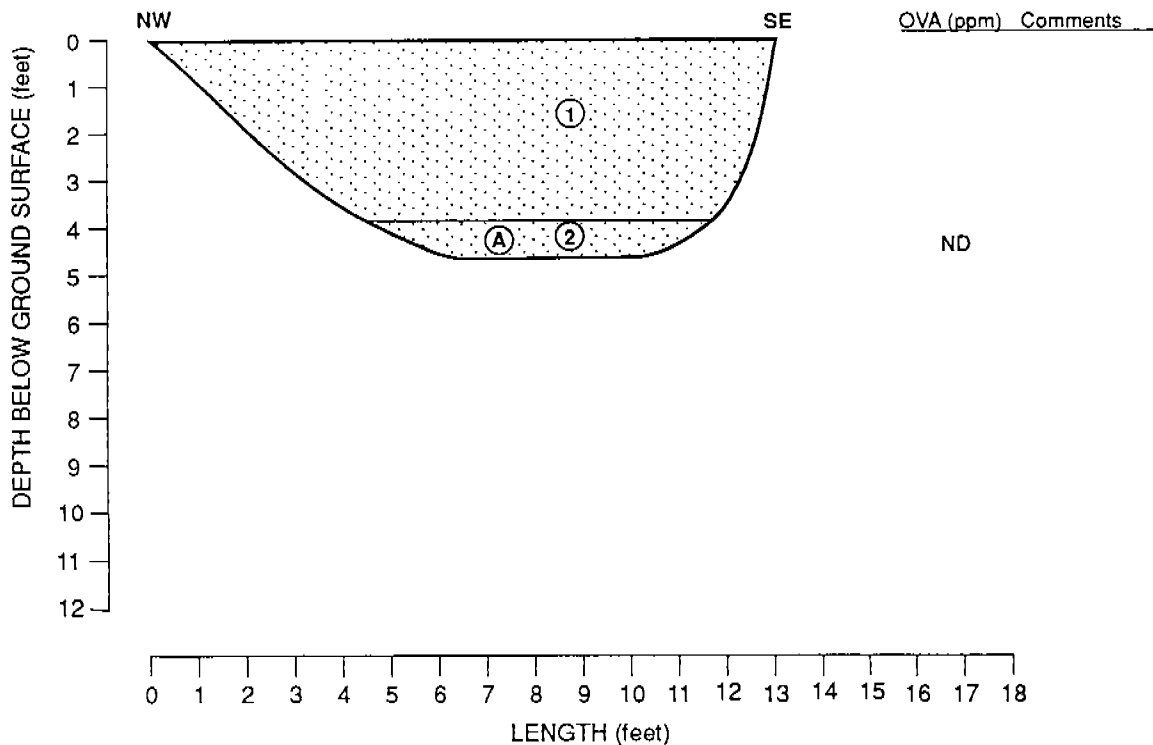

EXPLANATION:

- ① DARK BROWN SAND (SP) (10YR 4/3)
 very loose, dry, fine to medium sand,
 5-10% silt, trace roots to 1.5 feet, fill
- ② DARK YELLOWISH BROWN SAND (SP) (10YR 4/6)
 very loose, dry, fine to medium sand
- Ⓐ SAMPLE: 9333A016034F

070694AG



Hardling Lawson Associates
 Engineering and
 Environmental Services

Log of Test Pit TR-16-24
 Site 16-Pete's Pond Extension
 Volume II - RI, Basewide RI/FS
 Fort Ord, California

PLATE

A24

DRAWN: DJPc
 JOB NUMBER: 23366 041711

APPROVED: *RFM*

DATE: 10/93

REVISED DATE

Test Pit #: TR-16-25
 Date Started: 8-18-93
 Date Completed: 8-18-93
 Orientation: N30W
 Elevation: 141 feet at SE end

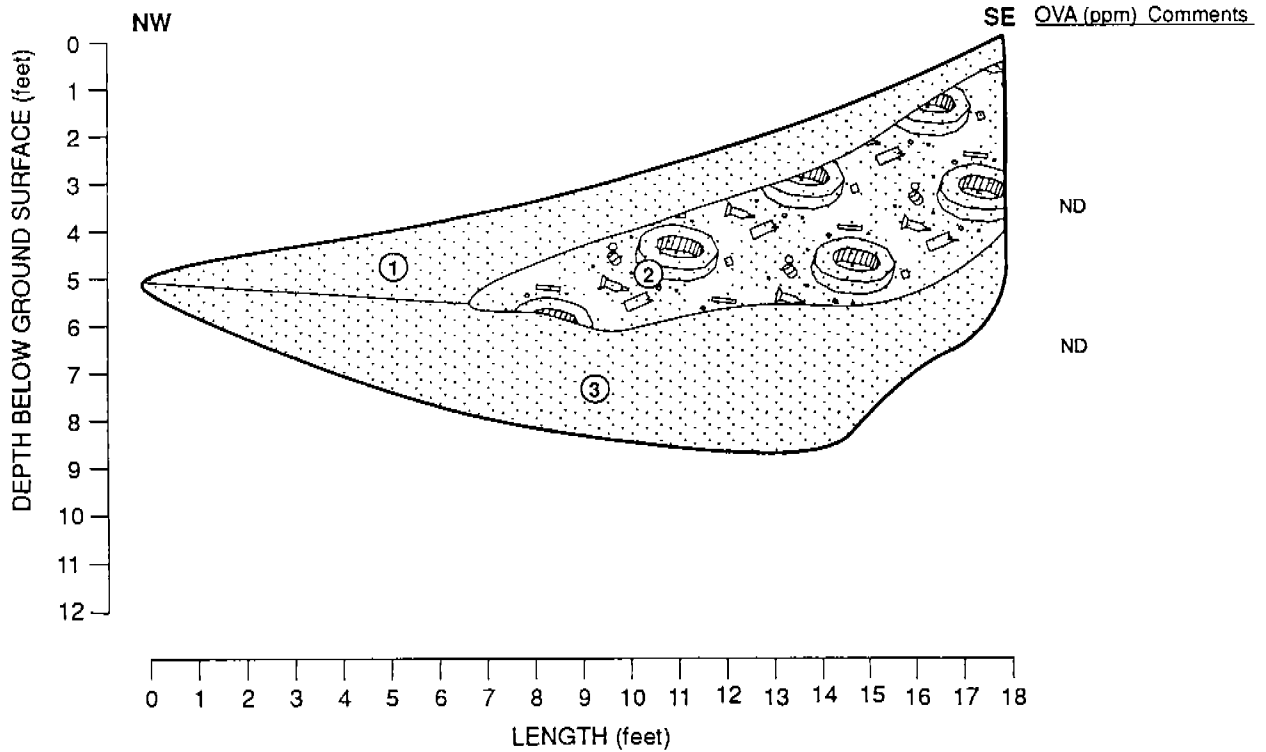

EXPLANATION:

- 
VERY DARK YELLOWISH BROWN SAND (SP) 10YR 3/4, very loose, dry, fine- to medium sand, 5-10% silt, trace roots, fill

- 
BROWN SAND WITH GRAVEL (SP) 10YR 4/3, very loose, dry, fine to medium sand, 5-10% gravel (up to 1/4"), 15-20% debris (mostly metal and glass, half pint whisky bottle, broken Coke bottles, metal lids, fuse box, nails, washers, bottle with cotton inside [medical?], charcoal/burnt wood) trace roots, fill

- 
BROWN POORLY GRAINED SAND (SP) 10YR 4/3, loose, dry, fine- to medium sand, 5% silt

070694AG



Harding Lawson Associates
 Engineering and
 Environmental Services

Log of Test Pit TR-16-25
 Site 16-Pete's Pond Extension
 Volume II - RI, Basewide RI/FS
 Fort Ord, California

PLATE

A25

DRAWN	JOB NUMBER	APPROVED	DATE	REVISED DATE
DJPC	23366 041711	RFM	10/93	

Test Pit #: TR-16-26
 Date Started: 8-18-93
 Date Completed: 8-18-93
 Orientation: N44W
 Elevation: 144 feet at SE end

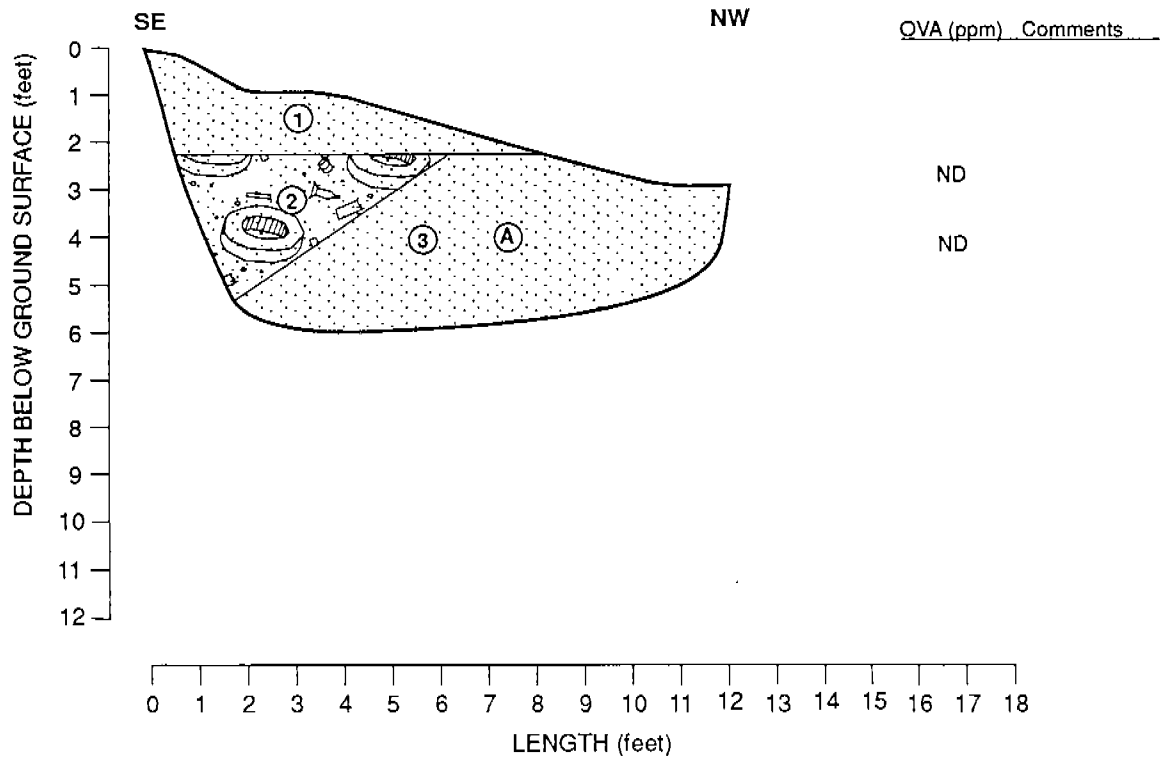

EXPLANATION:

- ① BROWN SAND (SP) (10YR 4/3) very loose, dry, fine to medium sand, 5-10% silt, trace roots, fill
 - ② DARK YELLOWISH BROWN SAND (SP) (10YR 3/4) very loose, dry to slightly moist, fine to medium sand, 25-30% metal debris (bedframe, bucket, water pipe, empty ammo container?, cable, 1945 smoke grenade), fill
 - ③ YELLOWISH BROWN SAND (SP) (10YR 5/6) loose, dry, fine to medium sand, trace silt
- Ⓐ SAMPLE: 9333A016040F

070694AG



Harding Lawson Associates
 Engineering and Environmental Services

Log of Test Pit TR-16-26
 Site 16-Pete's Pond Extension
 Volume II - RI, Basewide RI/FS
 Fort Ord, California

PLATE

A26

DRAWN	JOB NUMBER	APPROVED	DATE	REVISED DATE
DJPc	23366 041711	<i>RFM</i>	10/93	

Test Pit #: TR-16-27
 Date Started: 8-18-93
 Date Completed: 8-18-93
 Orientation: N44W
 Elevation: 149 feet

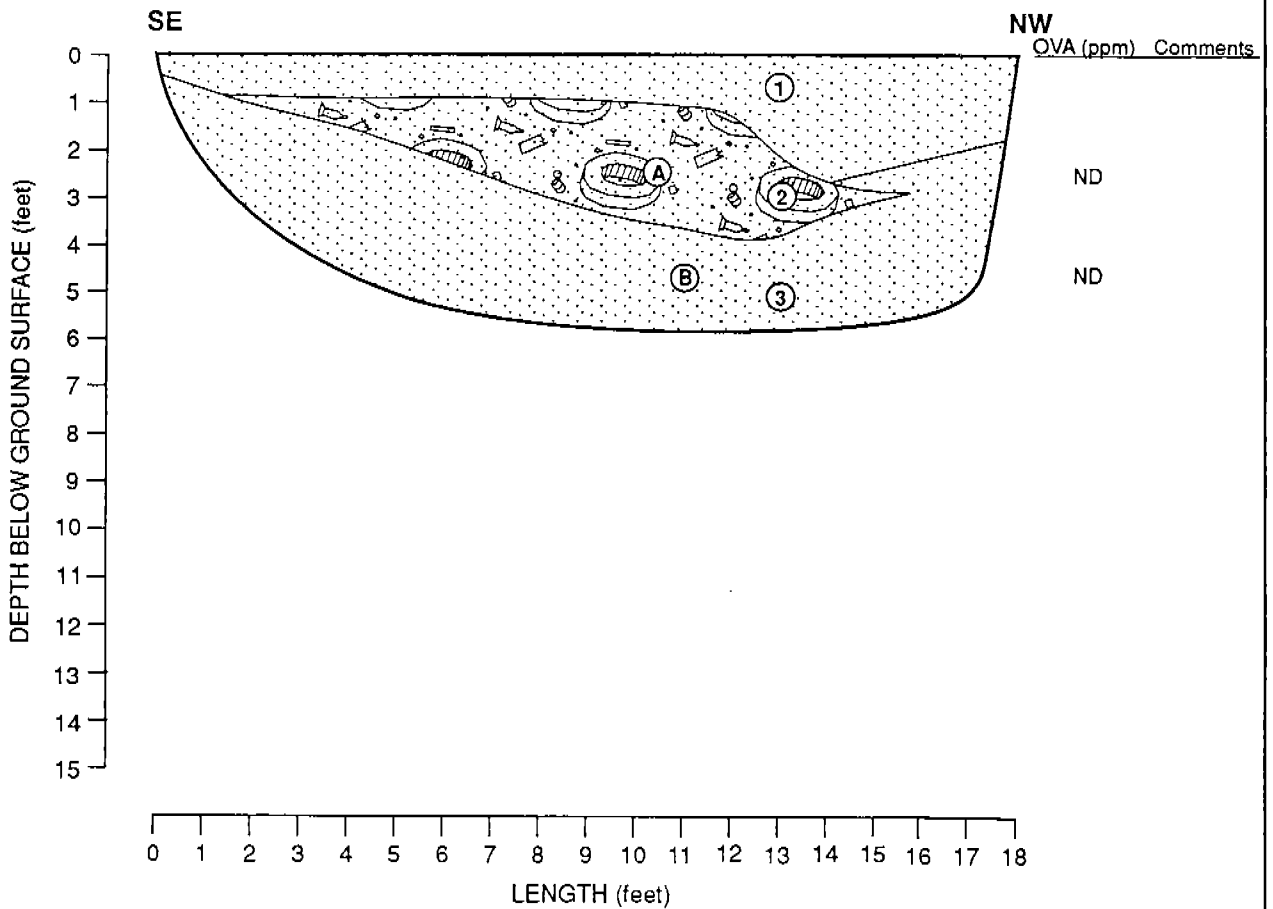

EXPLANATION:

- ① BROWNISH YELLOW AND DARK YELLOWISH BROWN SAND (SP), (10YR 6/6 and 10YR 3/4), very loose, dry, fine to medium sand, trace silt, laminations, fill
- ② BROWN SAND (SP) (10YR 5/3), very loose, dry, fine to medium sand, 5-10% silt, 10-20% metal debris (pipe, egg beater, can lids) and broken glass, fill
- ③ DARK YELLOWISH BROWN SAND (SP) 10YR 4/4, loose, dry, fine to medium sand, 5-10% silt
- (A) SAMPLE: 9333A016043F
- (B) SAMPLE: 9333A016042F

070694AG



Harding Lawson Associates
 Engineering and
 Environmental Services

Log of Test Pit TR-16-27
 Site 16-Pete's Pond Extension
 Volume II - RI, Basewide RI/FS
 Fort Ord, California

PLATE

A27

DRAWN	JOB NUMBER	APPROVED	DATE	REVISED DATE
DJPC	23366 041711	RFM	11/93	

Test Pit #: TR-16-28
 Date Started: 8-19-93
 Date Completed: 8-19-93
 Orientation: N70E
 Elevation: 149 feet at E end

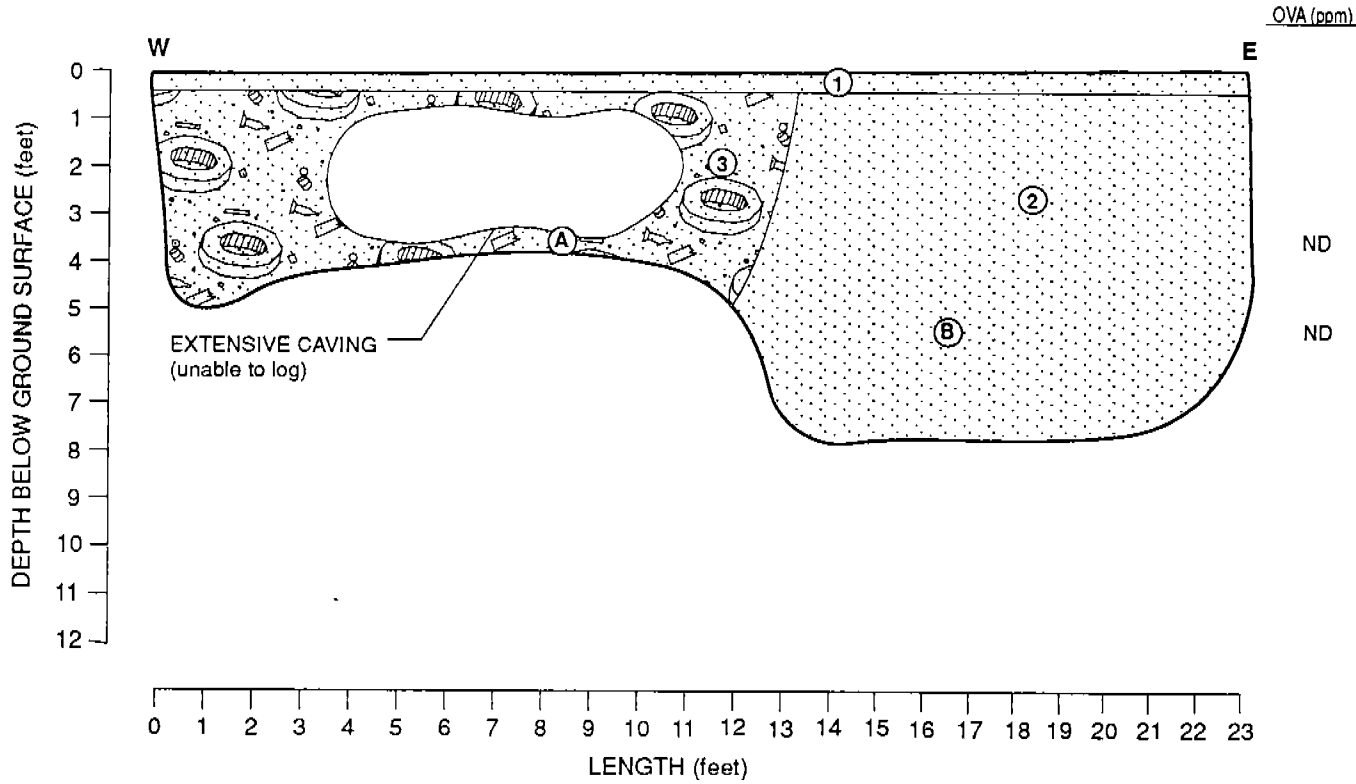

- EXPLANATION:**
- ① BROWNISH YELLOW SAND (SP) (10YR 4/3 & 10YR 6/6), very loose, dry, fine to medium sand, trace to 10% silt, trace roots, laminated
 - ② DARK YELLOWISH BROWN SAND (SP) (10YR 4/6), very loose to loose, dry to slightly moist, fine to medium sand, trace silt
 - ③ DARK BROWN SAND (SP) (10YR 3/3), very loose, dry, fine to medium sand, trace silt, 25-30% debris (wire mesh [screen], piston, pullies, drive line with bearing housing, 55 gallon drum [4 ppm], metal pipe, chain link fence), fill
 - Ⓐ SAMPLE: 9333A016047F
 - Ⓑ SAMPLE: 9333A016046F

Note: Unable to excavate deeper in west portion of test pit due to extensive debris

070694AG



Harding Lawson Associates
 Engineering and Environmental Services

Log of Test Pit TR-16-28
 Site 16—Pete's Pond Extension
 Volume II - RI, Basewide RI/FS
 Fort Ord, California

PLATE

A28

DRAWN	JOB NUMBER	APPROVED	DATE	REVISED DATE
DJPC	23366 041711	<i>RFL</i>	11/93	

Test Pit #: TR-16-29
 Date Started: 8-19-93
 Date Completed: 8-19-93
 Orientation: N75E
 Elevation: 156 feet at E end

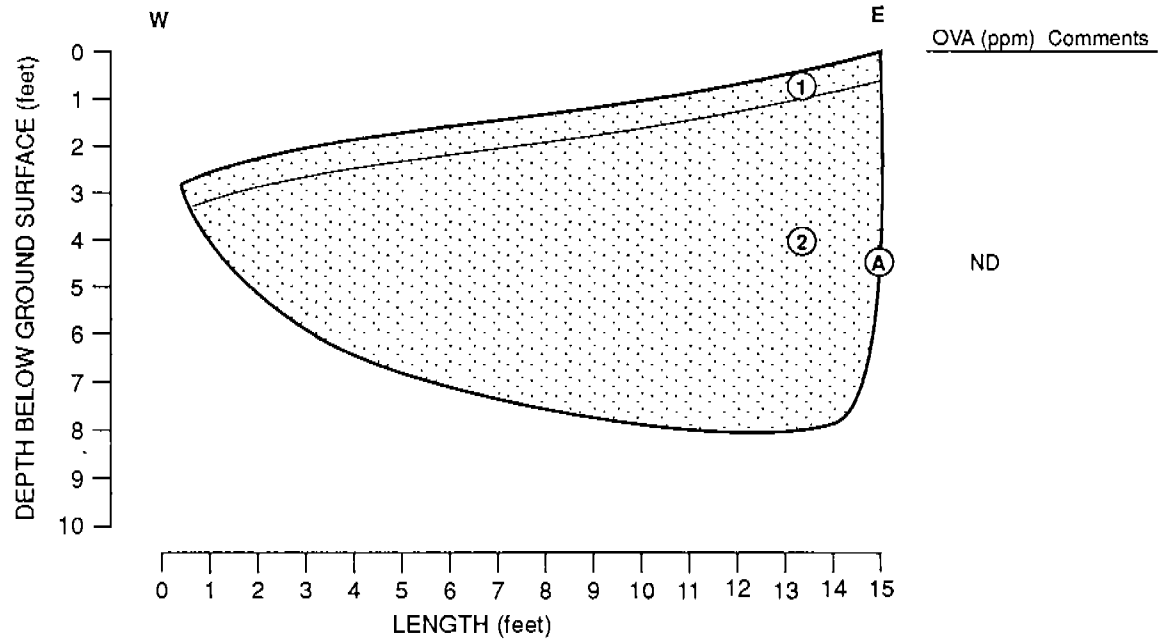

- EXPLANATION:**
- ① BROWN SAND (SP) (10YR 5/3), very loose, dry, fine to medium sand, trace to 10% silt, trace roots (iceplant), fill
 - ② VERY DARK BROWN AND DARK YELLOWISH BROWN SAND (SP) (10YR 2/2, 10YR 3/4 and 10YR 4/6), loose, slightly moist, fine to medium sand, trace silt, laminated, fill
 - Ⓐ SAMPLE: 9333A016048F

070694AG



Harding Lawson Associates
 Engineering and
 Environmental Services

Log of Test Pit TR-16-29
 Site 16—Pete's Pond Extension
 Volume II - RI, Basewide RI/FS
 Fort Ord, California

PLATE

A29

DRAWN DJP	JOB NUMBER 23366 041711	APPROVED <i>RFM</i>	DATE 10/93	REVISED DATE
--------------	----------------------------	------------------------	---------------	--------------

Test Pit #: TR-16-30
 Date Started: 8-19-93
 Date Completed: 8-19-93
 Orientation: N79W
 Elevation: 152 feet

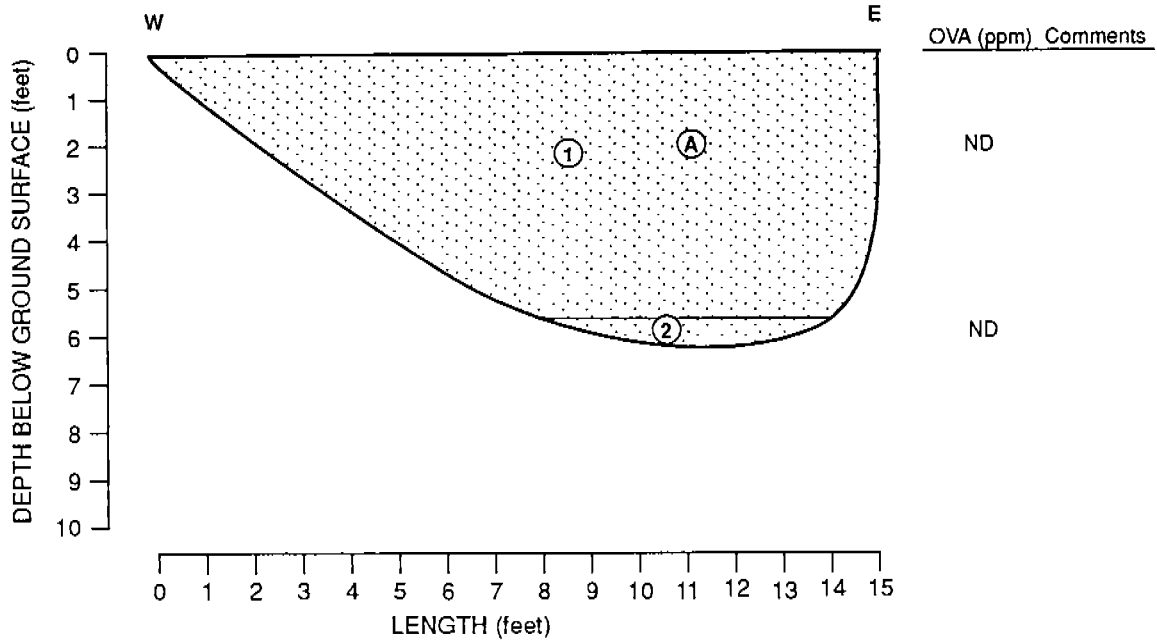

EXPLANATION:

- ① DARK BROWN SAND (SP) (10YR 3/3), very loose, moist, fine to medium sand, 5-10% silt, trace roots
- ② DARK YELLOWISH BROWN SAND (SP) (10YR 4/6), very loose, moist, fine to medium sand, trace silt
- Ⓐ SAMPLE: 9333A016049F

070694AG

PLATE



Harding Lawson Associates
 Engineering and
 Environmental Services

Log of Test Pit TR-16-30
 Site 16—Pete's Pond Extension
 Volume II - RI, Basewide RI/FS
 Fort Ord, California

A30

DRAWN	JOB NUMBER	APPROVED	DATE	REVISED DATE
DJP	23366 041711	<i>RFM</i>	10/93	

Test Pit #: TR-16-31
 Date Started: 8-19-93
 Date Completed: 8-20-93
 Orientation: N60E
 Elevation: 148 feet

OVA (ppm) Comments

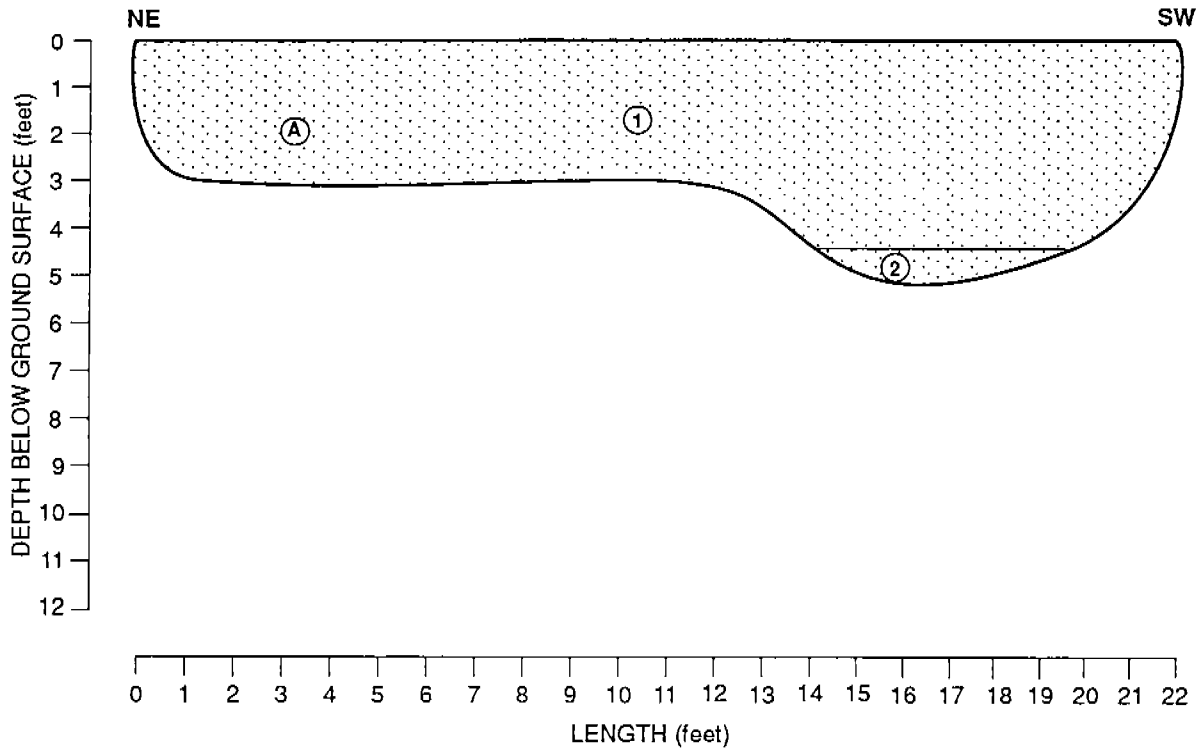

EXPLANATION:



DARK BROWN SAND (SP) (10YR 3/3), very loose, moist, fine to medium sand, 5-10% silt, up to 5% roots in upper 1', steel cable at surface



DARK YELLOW BROWN SAND (SP) (10YR 4/4), very loose, moist, fine to medium sand, trace silt



SAMPLE: 9333A016051F

070694AG

PLATE



Harding Lawson Associates
 Engineering and
 Environmental Services

Log of Test Pit TR-16-31
 Site 16-Pete's Pond Extension
 Volume II - RI, Basewide RI/FS
 Fort Ord, California

A31

DRAWN: DJPc
 JOB NUMBER: 23366 041711

APPROVED: *RFM*

DATE: 11/93

REVISED DATE

Test Pit #: TR-16-32
 Date Started: 8-20-93
 Date Completed: 8-20-93
 Orientation: N45W
 Elevation: 138 feet

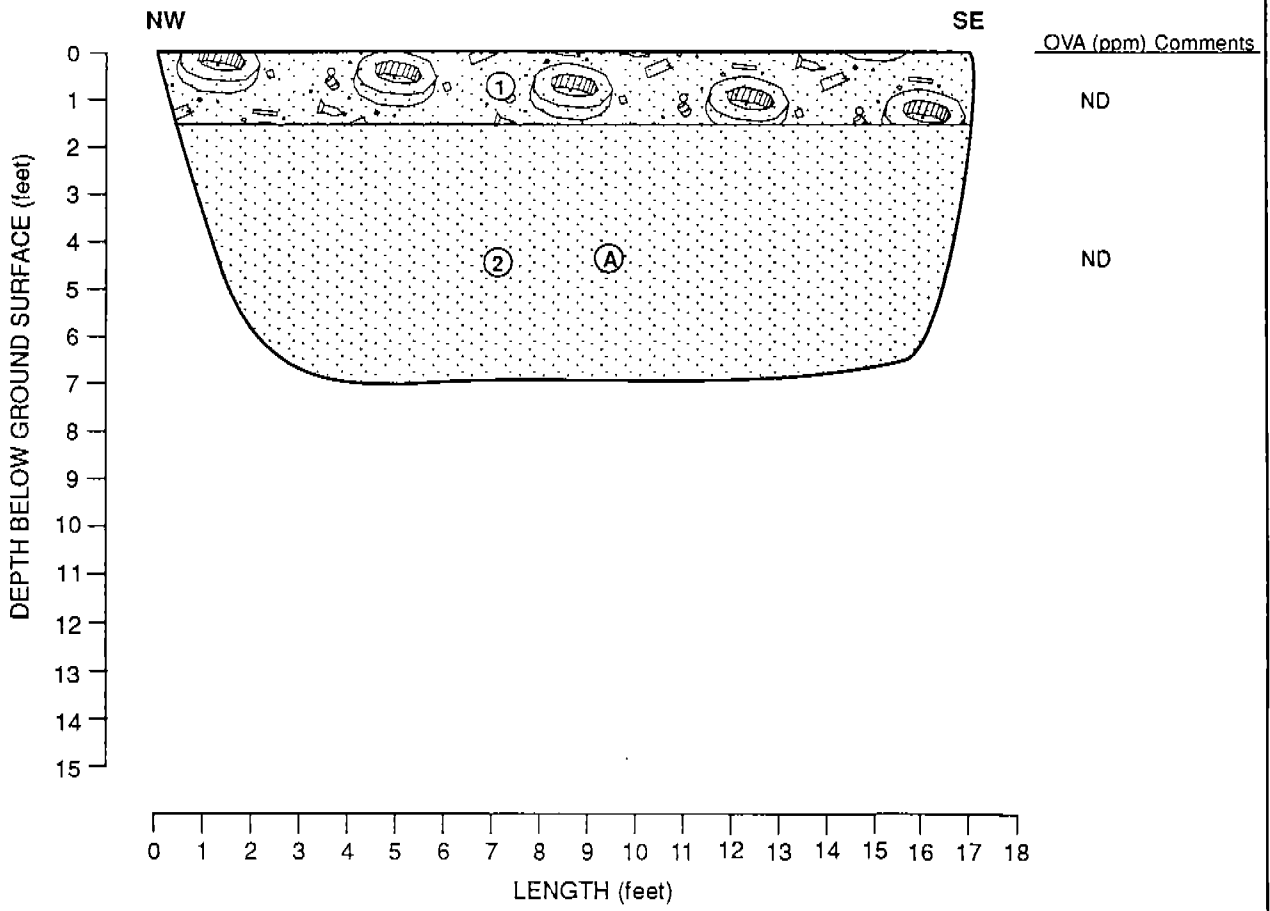

- EXPLANATION:**
- BROWN SAND (SP) (10YR 4/3), very loose, dry, fine to medium sand, 5-10% silt, trace debris (rusted metal/rust colored soil, burnt wood, broken glass, gravel), fill
 - VERY DARK BROWN SAND (SP) (10YR 2/2), very loose, moist, fine to medium sand, 5-10% silt
 - SAMPLE: 9333A016055F

070694AG



Harding Lawson Associates
 Engineering and Environmental Services

Log of Test Pit TR-16-32
 Site 16-Pete's Pond Extension
 Volume II - RI, Basewide RI/FS
 Fort Ord, California

PLATE

A32

DRAWN DJPC	JOB NUMBER 23366 041711	APPROVED <i>RFM</i>	DATE 11/93	REVISED DATE
---------------	----------------------------	------------------------	---------------	--------------

Test Pit #: TR-16-33
 Date Started: 8-20-93
 Date Completed: 8-20-93
 Orientation: N40E
 Elevation: 140 feet

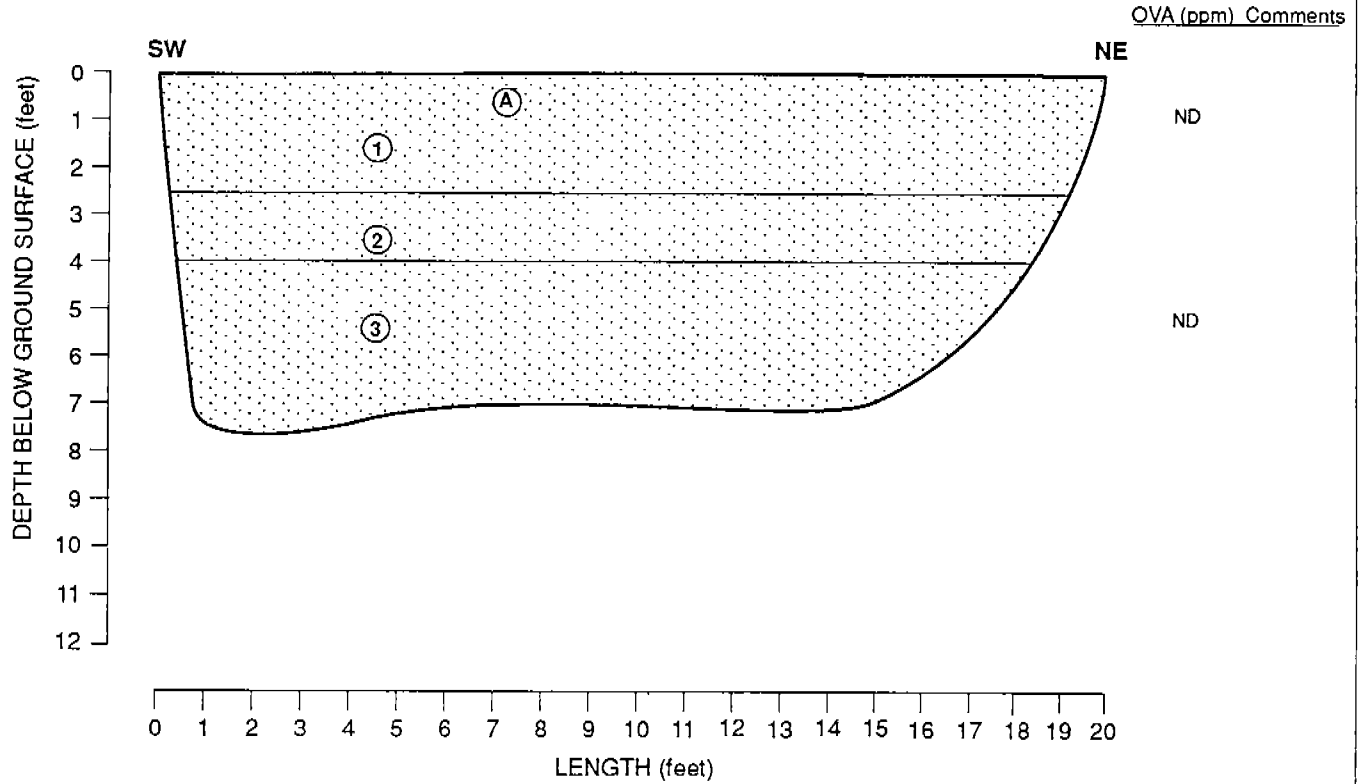

- EXPLANATION:**
- ① DARK BROWN SAND (SP) (10YR 3/3) very loose, moist, fine to medium sand, 5-10% silt, trace roots (in upper 6" only)
 - ② LIGHT YELLOWISH BROWN AND DARK YELLOWISH BROWN SAND (SP) (10YR 6/4 TO 10YR 3/6), very loose, moist, fine to medium sand, trace silt, laminated
 - ③ DARK BROWN SAND (SP) (10YR 3/3), very loose, moist, fine to medium sand, 5-10% silt
 - Ⓐ SAMPLE: 9333A016056F

070694AG



Harding Lawson Associates
 Engineering and
 Environmental Services

Log of Test Pit TR-16-33
 Site 16—Pete's Pond Extension
 Volume II - RI, Basewide RI/FS
 Fort Ord, California

PLATE

A33

DRAWN: DJPc
 JOB NUMBER: 23366 041711

APPROVED: *RFM*

DATE: 10/93

REVISED DATE

Test Pit #: TR-16-34
 Date Started: 8-20-93
 Date Completed: 8-20-93
 Orientation: N40E
 Elevation: 144 feet

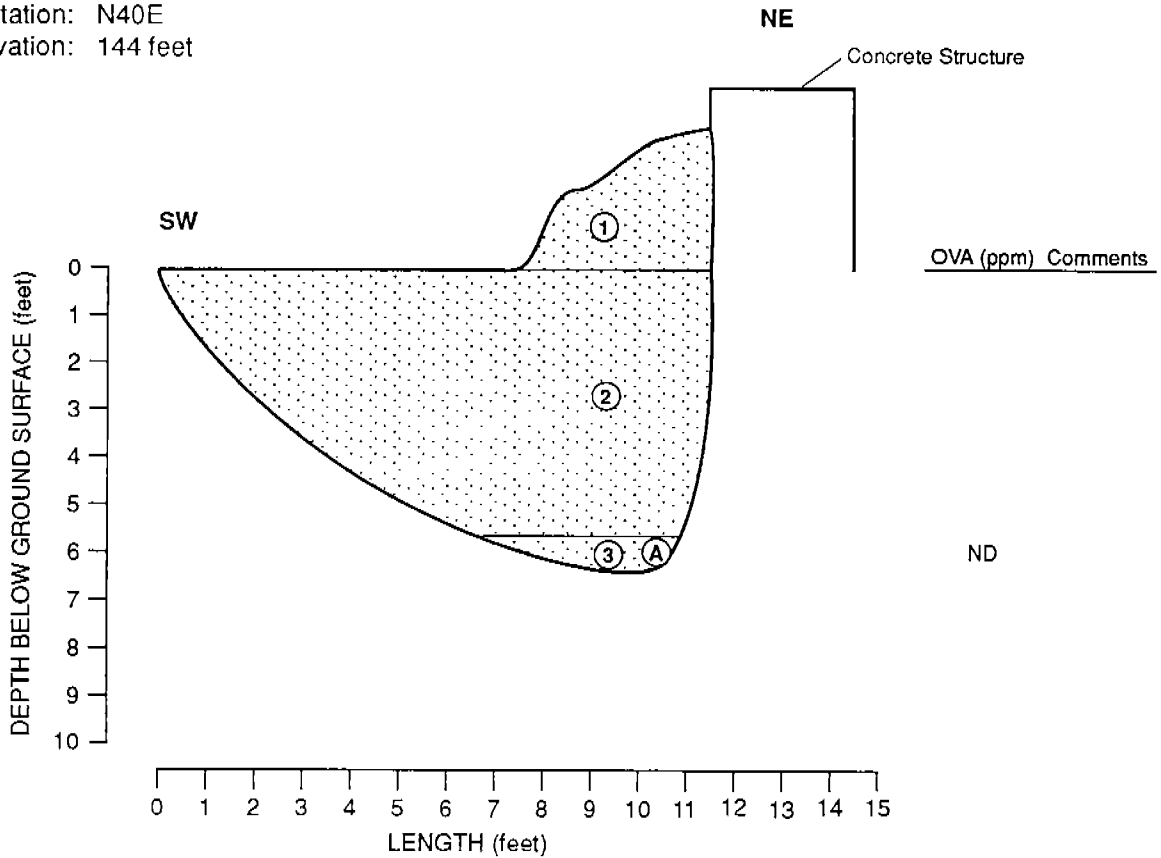

EXPLANATION:

- ① MIXED BROWNISH YELLOW TO DARK YELLOWISH BROWN SAND (SP) (10YR 6/6 to 10YR 3/4), very loose, dry, fine to medium sand, trace to 10% silt, 2.36" rocket bazooka round, fill
- ② DARK YELLOWISH BROWN SAND (SP) (10YR 3/4), very loose, moist, fine to medium sand, 5-10% silt, 5% roots within upper 1'
- ③ YELLOWISH BROWN SAND (SP) (10YR 5/6), very loose, moist, fine to medium sand, trace silt
- Ⓐ SAMPLE: 9333A016058F

070694AG



Harding Lawson Associates
 Engineering and
 Environmental Services

Log of Test Pit TR-16-34
 Site 16—Pete's Pond Extension
 Volume II - RI, Basewide RI/FS
 Fort Ord, California

PLATE

A34

DRAWN	JOB NUMBER	APPROVED	DATE	REVISED DATE
DJPC	23366 041711	<i>RFL</i>	11/93	

Test Pit #: TR-16-35
 Date Started: 8-20-93
 Date Completed: 8-20-93
 Orientation: N65E
 Elevation: 144 feet at E end

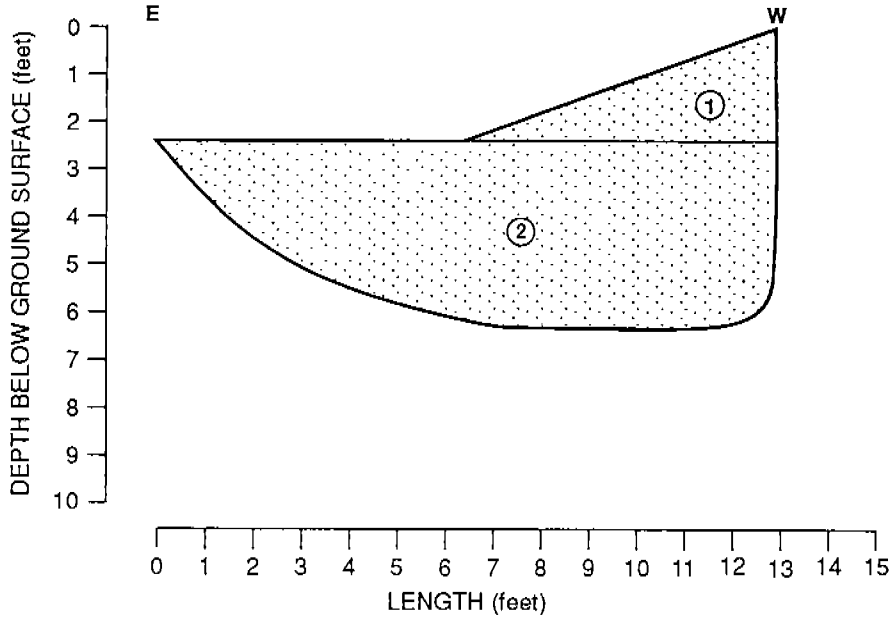

OVA (ppm) Comments

EXPLANATION:

① DARK GRAYISH BROWN SAND TO SILTY SAND (SP-SM) (10YR 4/2) very loose, dry, fine to medium sand, 10-15% silt, 5-10% roots and dead plants, bazooka round (2.36" rocket), fill

② DARK YELLOWISH BROWN SAND (SP) (10YR 4/4) very loose, slightly moist, fine to medium sand, 5-10% silt, trace roots

Ⓐ SAMPLE: 9333A0016059F (Exact sampling location not known)

070694AG



Harding Lawson Associates
 Engineering and
 Environmental Services

Log of Test Pit TR-16-35
 Site 16-Pete's Pond Extension
 Volume II - RI, Basewide RI/FS
 Fort Ord, California

PLATE

A35

DRAWN: DJP
 JOB NUMBER: 23366 041711

APPROVED: RFM

DATE: 10/93

REVISED DATE

Test Pit #: TR-16-36
 Date Started: 8-20-93
 Date Completed: 8-20-93
 Orientation: N90E
 Elevation: 154 feet

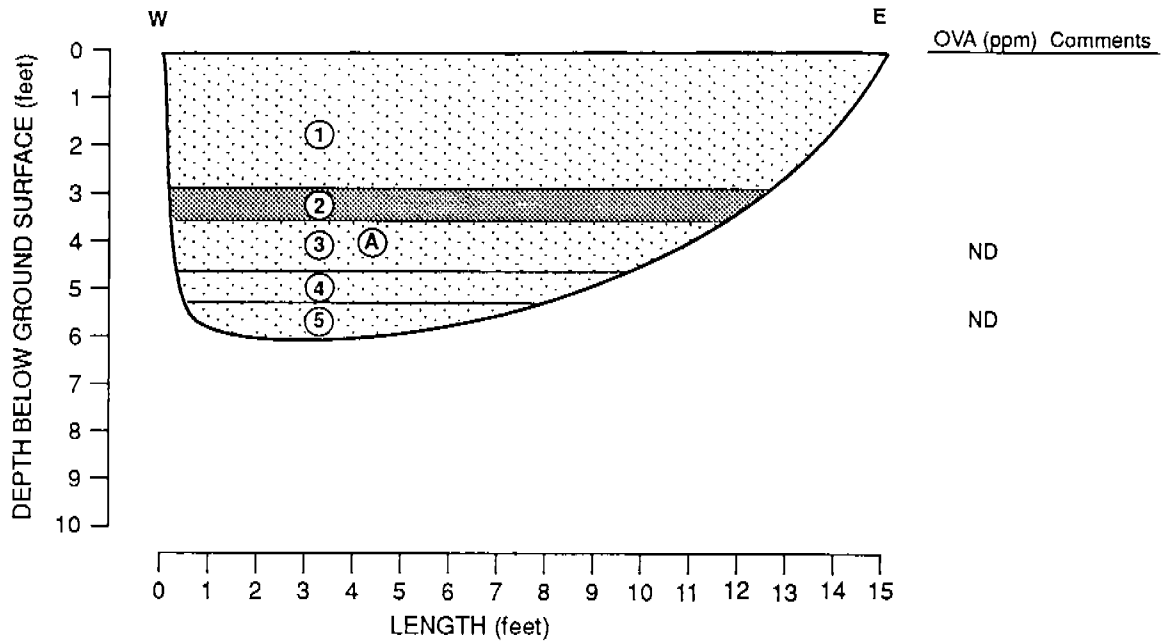

- EXPLANATION:**
- ① VERY DARK GRAYISH BROWN SAND (SP) (10YR 3/2)
very loose, dry, fine to medium sand, 10-15% silt, trace gravel to 1/4", 5% roots in upper 1', fill
 - ② ASPHALT AND BASEROCK LAYER, broken pieces of asphalt with bluish baserock
 - ③ DARK YELLOWISH BROWN SAND (SP) (10YR 3/4)
very loose, moist, fine to medium sand, 5-10% silt, laminated
 - ④ VERY DARK BROWN SAND (SP) (10YR 2/2)
loose, moist, fine- to medium-grained sand, trace silt
 - ⑤ DARK YELLOWISH BROWN SAND (SP) (10YR 3/4)
loose, moist, fine to medium sand, trace silt
 - Ⓐ SAMPLE: 9333A016060F

070694AG



Harding Lawson Associates
 Engineering and
 Environmental Services

Log of Test Pit TR-16-36
 Site 16-Pete's Pond Extension
 Volume II - RI, Basewide RI/FS
 Fort Ord, California

PLATE

A36

DRAWN	JOB NUMBER	APPROVED	DATE	REVISED DATE
DJP	23366 041711	<i>RFM</i>	10/93	

Test Pit #: TR-16-37
 Date Started: 8-25-93
 Date Completed: 8-25-93
 Orientation: N32W
 Elevation: 139 feet at SE end

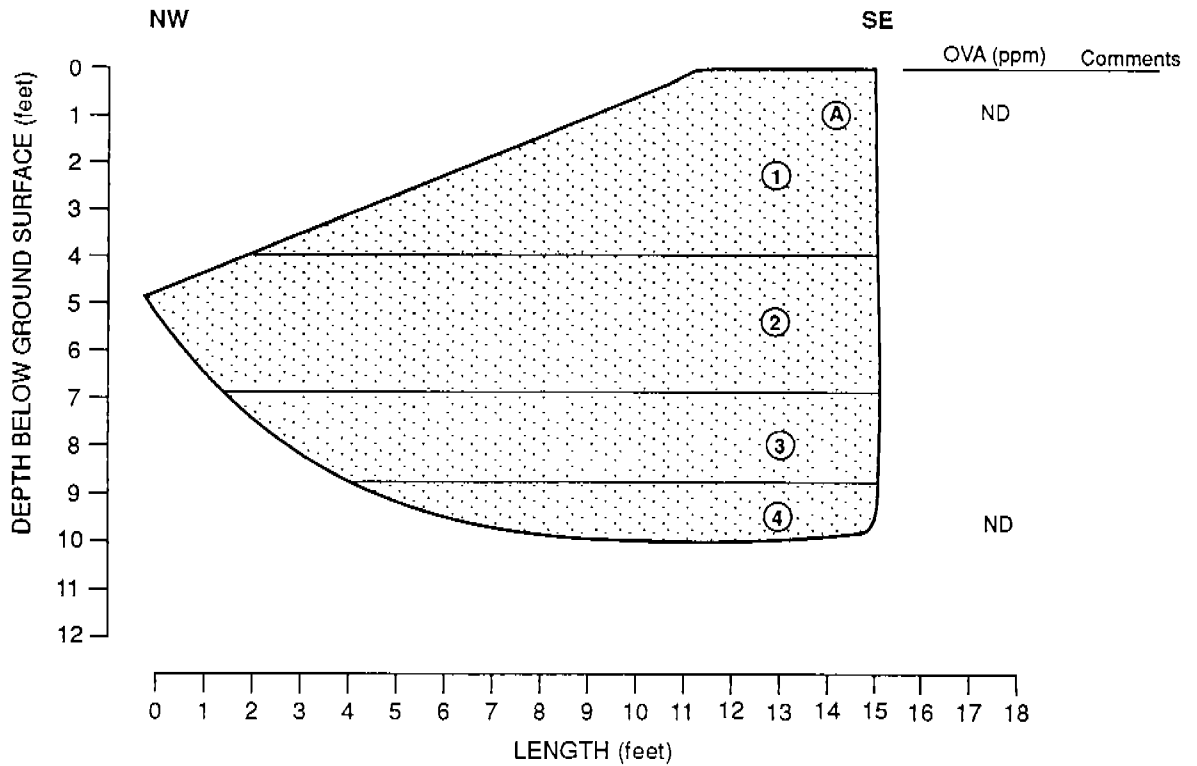

EXPLANATION:

- ① BROWN SAND (SP) (10YR 4/3) very loose, dry, fine to medium sand, 5-10% silt, trace plant roots, trace gravel to 3", trace glass fragments, fill
- ② DARK BROWN SAND (SP) (10YR 3/3) very loose, moist, fine to medium sand, trace to 10% silt, trace roots
- ③ BROWN SAND (SP) (10YR 4/3) very loose, moist, fine to medium sand, trace to 10% silt, trace plant roots
- ④ BROWNISH YELLOW SAND (SP) (10YR 6/6) very loose, moist, fine to medium sand
- Ⓐ SAMPLE: 9334016A076F

070694AG

PLATE



Harding Lawson Associates

Engineering and
Environmental Services

Log of Test Pit TR-16-37

Site 16-Pete's Pond Extension
 Volume II - RI, Basewide RI/FS
 Fort Ord, California

A37

DRAWN	JOB NUMBER	APPROVED	DATE	REVISED DATE
DJP	23366 041711	<i>RFA</i>	10/93	

Test Pit #: TR-16-38
 Date Started: 8-26-93
 Date Completed: 8-26-93
 Orientation: N47W
 Elevation: 150 feet at SE end

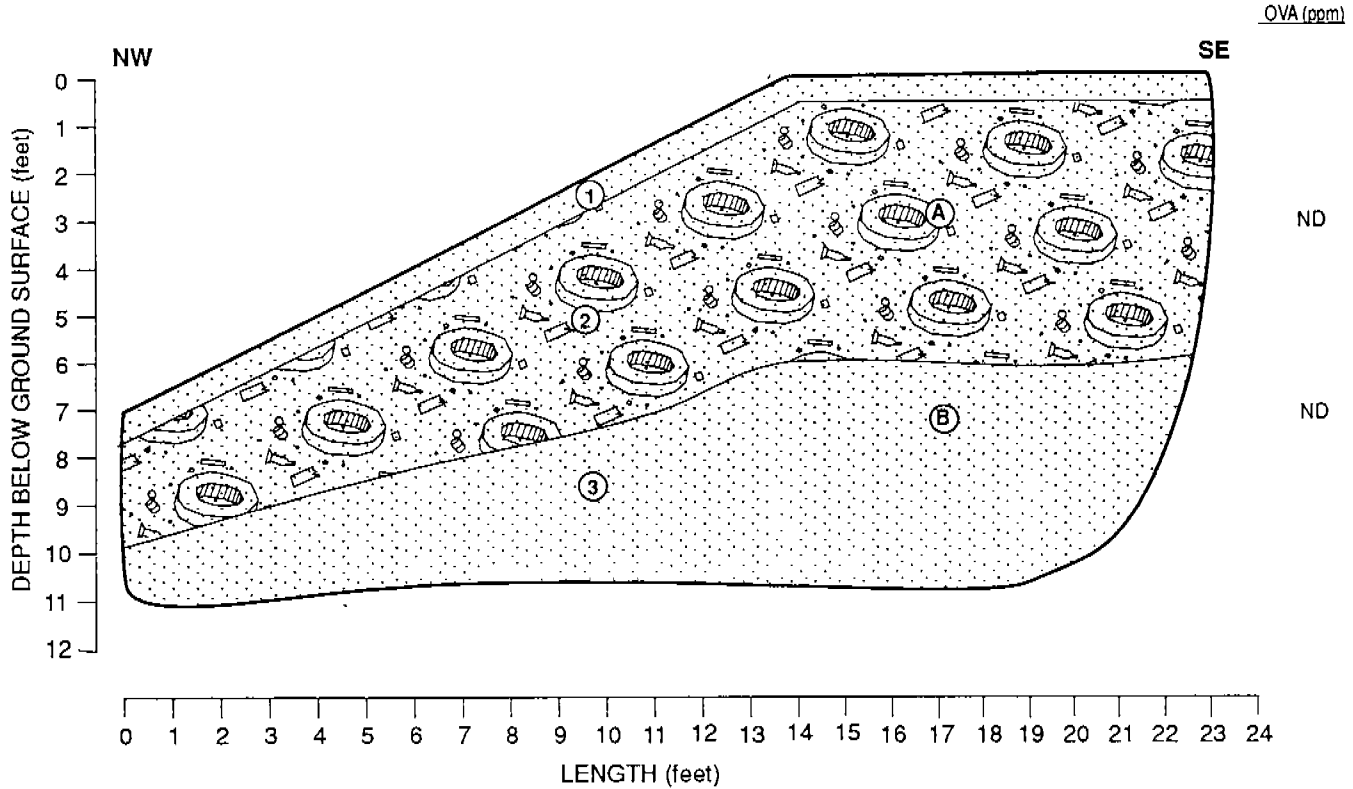

EXPLANATION:

- ① BROWN SAND (SP) (10YR 5/3), very loose, dry, fine to medium sand, trace silt, trace roots, fill
- ② DARK GRAYISH BROWN SAND (SP) (10YR 4/2), very loose, dry, fine to medium sand, 5-10% silt, 5-10% debris (abalone shells, melted glass, metal band, ceramic plate, metal fence posts, wire, cable, shoes, burnt wood, can lids), fill
- ③ DARK YELLOWISH BROWN SAND (SP) (10YR 4/6), very loose, dry, fine to medium sand
- Ⓐ SAMPLE: 9334016A080F
- Ⓑ SAMPLE: 9334016A081F

070694AG

PLATE



Harding Lawson Associates
 Engineering and
 Environmental Services

Log of Test Pit TR-16-38
 Site 16-Pete's Pond Extension
 Volume II - RI, Basewide RI/FS
 Fort Ord, California

A38

DRAWN	JOB NUMBER	APPROVED	DATE	REVISED DATE
DJPC	23366 041711	RFM	11/93	

Test Pit #: TR-16-39
 Date Started: 8-26-93
 Date Completed: 8-26-93
 Orientation: N70W
 Elevation: 151 feet

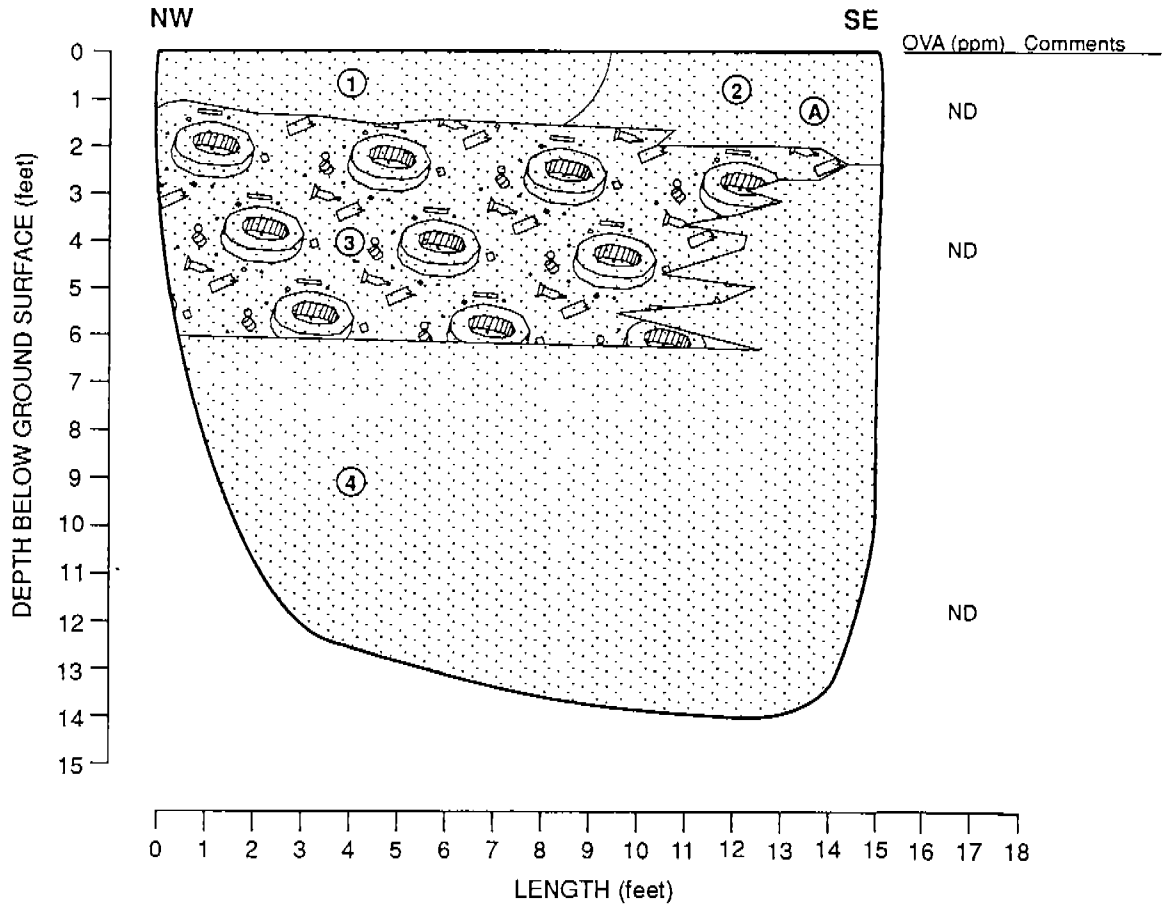

EXPLANATION:

- ① BROWN SAND (SP) (10YR 5/3), very loose, dry, fine to medium sand, 5-10% silt, trace roots, fill
- ② DARK BROWN SAND (SP) (10YR 3/3), loose, dry, fine to medium sand, 5-10% silt, appears to be more compacted than 1 above, fill
- ③ BROWN SAND (SP) (10YR 4/3), very loose, dry, fine to medium sand, 5-10% silt, 10-15% debris (wire, nails, brake drum, burnt wood, small springs, broken glass, rusted metal), fill
- ④ BROWN SAND (SP) (10YR 4/3), very loose, dry to slightly moist, fine to medium sand, trace to 10% silt
- Ⓐ SAMPLE: 9334016A084F

070694AG

PLATE



Harding Lawson Associates
 Engineering and
 Environmental Services

Log of Test Pit TR-16-39
 Site 16-Pete's Pond Extension
 Volume II - RI, Basewide RI/FS
 Fort Ord, California

A39

DRAWN: DJPc
 JOB NUMBER: 23366 041711

APPROVED: RFM

DATE: 9/93

REVISED DATE

Test Pit #: TR-16-40
 Date Started: 8-26-93
 Date Completed: 8-27-93
 Orientation: N28E
 Elevation:

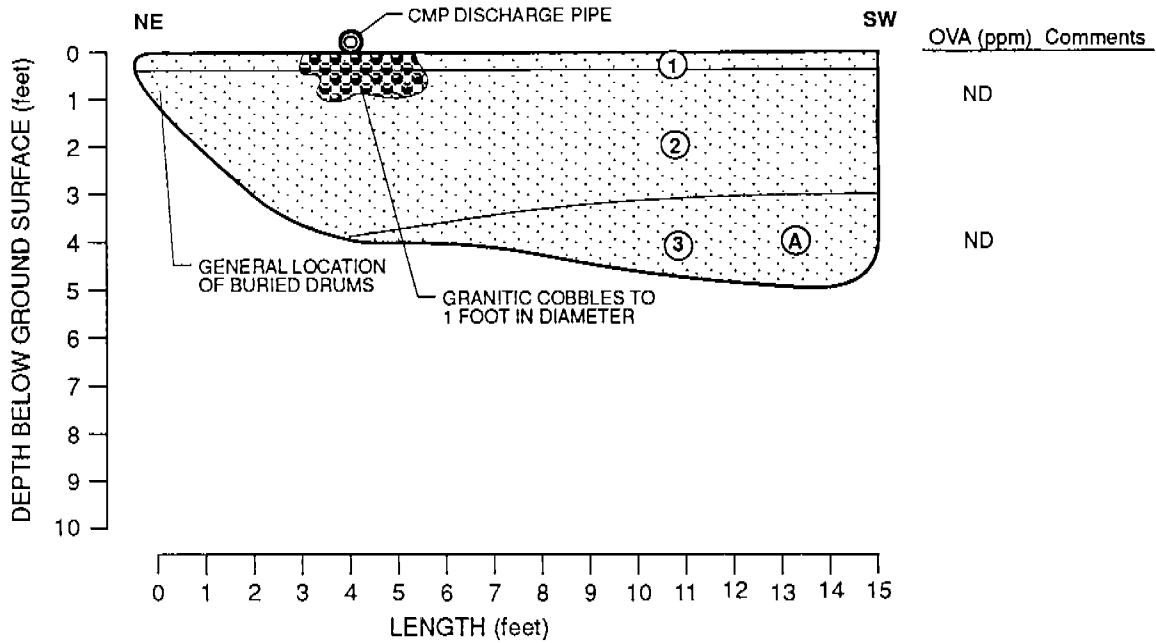

EXPLANATION:

- ① DARK GRAYISH BROWN SAND (SP) (10YR 4/2), very loose, dry, fine to medium sand, 5-10% silt, 5-10% roots, fill
- ② BROWN SAND (SP) (10YR 4/3), very loose, dry, fine to medium sand, 5-10% silt, two 55-gallon drums (one filled with sand and one empty at NE end of test pit, one drum may have been used to store mustard agent based on drum type identification), fill
- ③ YELLOWISH BROWN SAND (SP) (10YR 5/6), very loose, dry, fine to medium sand
- Ⓐ SAMPLE: 9334A016088F

070694AG



Harding Lawson Associates
 Engineering and
 Environmental Services

Log of Test Pit TR-16-40
 Site 16-Pete's Pond Extension
 Volume II - RI, Basewide RI/FS
 Fort Ord, California

PLATE

A40

DRAWN	JOB NUMBER	APPROVED	DATE	REVISED DATE
DJPc	23366 041711	<i>Rfm</i>	10/93	

Test Pit #: TR-16-41
 Date Started: 3-14-94
 Date Completed: 3-14-94
 Orientation: N52W
 Elevation:

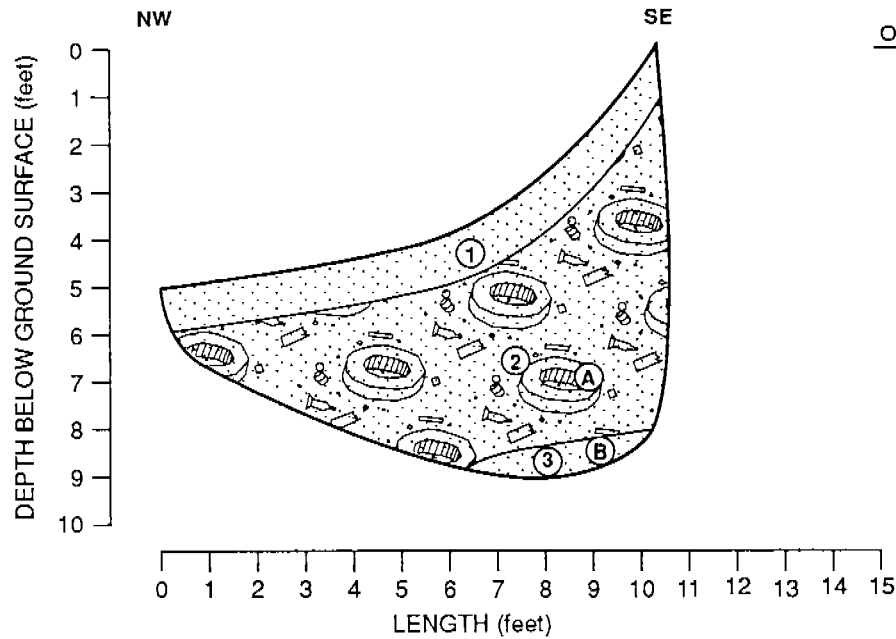

OVA (ppm) Comments

ND

ND

ND

EXPLANATION:



DARK YELLOWISH BROWN SAND (SP) (10YR 3/4), loose, moist, fine sand, 10-15% silt, trace debris and root hairs, fill



DEBRIS AND DARK YELLOWISH BROWN SAND (SP) (10YR 3/4), loose, moist, 60% debris (glass fragments, bottles, chain link fence, 5/8" steel cable, bacon tins, film plates, flashlight, bulb, vehicle axle, gray unidentified liquid, vehicle bumper, assorted plastic-lined 5-gallon buckets, ammo boxes, ordnance parts to rifle grenades, reinforcement rings [as seen on mustard drums], long cylindrical object - potential 500-lb bomb per UXB guess before wall cave-in), 35% fine sand, 5% silt, fill



YELLOWISH BROWN SAND (SP) (10YR 5/6), loose, moist, fine sand, 35% debris (see above)



SAMPLE: 9411G016146F



SAMPLE: 9411G016147F

070694AG



Harding Lawson Associates

Engineering and
Environmental Services

Log of Test Pit TR-16-41

Site 16-Pete's Pond Extension
 Volume II - RI, Basewide RI/FS
 Fort Ord, California

PLATE

A41

DRAWN
DJPC

JOB NUMBER
23366 041711

APPROVED
RFM

DATE
10/93

REVISED DATE

TR-17-01
 WEST TOWARD STORAGE BUILDINGS
 TOWARD FIFTH AVENUE

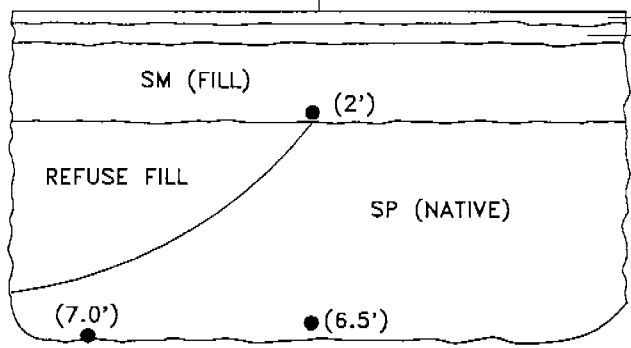

ASPHALT
 GRAY SANDY GRAVEL (GP), BASEROCK

- SM DARK YELLOWISH BROWN SILTY SAND (SM) (10YR4/4) LOOSE, MOIST, 85% FINE-TO MEDIUM-GRAINED SAND, 15% SILT
 - SP YELLOW SAND (SP) (10YR7/6) LOOSE, MOIST, 95% FINE-TO MEDIUM-GRAINED SAND, 5% SILT
 - FILL SCRAP METAL, HEAT-DEFORMED GLASS, NAILS, ~50 ml OF GREEN CRUMBLY MATERIAL (BAG SAMPLE COLLECTED)
- NO SOIL OVA READINGS DETECTED

TR-17-02
 WEST TOWARD STORAGE BUILDINGS
 TOWARD FIFTH AVENUE

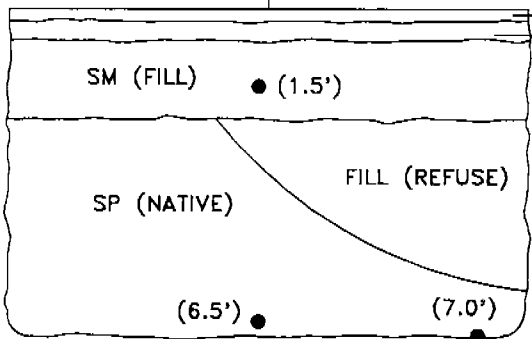

ASPHALT
 GRAY SANDY GRAVEL (GP), BASEROCK

- SM DARK YELLOWISH BROWN SILTY SAND (SM) (10YR4/4) LOOSE, MOIST, 85% FINE-TO MEDIUM-GRAINED SAND, 15% SILT
 - SP YELLOW SAND (SP) (10YR7/6) LOOSE, MOIST, 95% FINE-TO MEDIUM-GRAINED SAND, 5% SILT
 - FILL SCRAP METAL, PORCELAIN, ASPHALT, HEAT-DEFORMED GLASS, NAILS, CHARRED WOOD
- NO SOIL OVA READINGS DETECTED

EXPLANATION
 ● TRENCH SAMPLE LOCATION

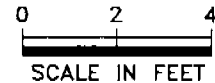

Harding Lawson Associates
 Engineering and Environmental Services

Exploratory Trenches - TR-17-01 and TR-17-02
 Site 17 - 1400 Block Motor Pool and Suspected Disposal Area
 Site Characterization
 Fort Ord, California

PLATE

A42

DRAWN YG	PROJECT NUMBER 23366 041711	APPROVED <i>[Signature]</i>	DATE 4/93	REVISED DATE
-------------	--------------------------------	--------------------------------	--------------	--------------

7579131_2.0

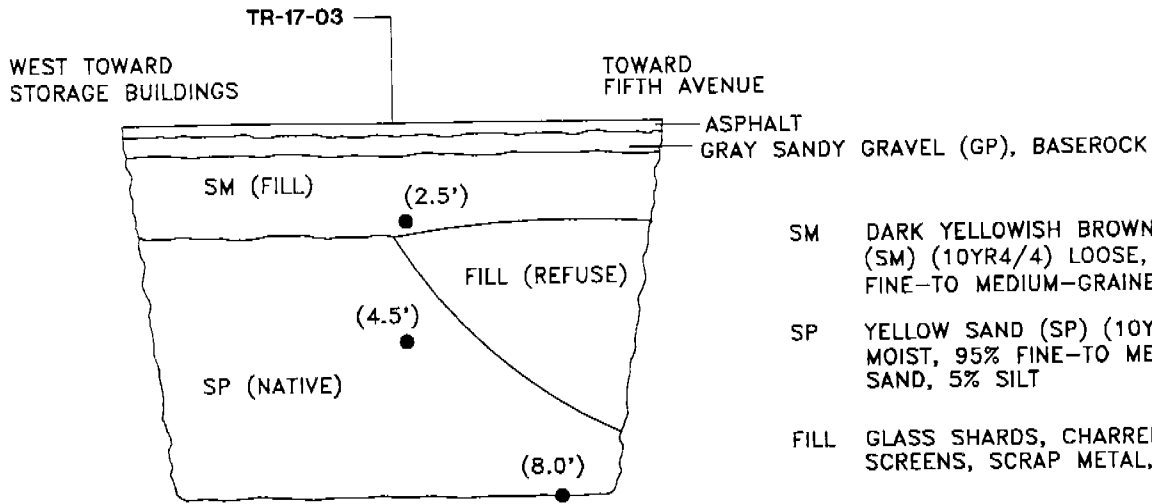

- SM DARK YELLOWISH BROWN SILTY SAND (SM) (10YR4/4) LOOSE, MOIST, 85% FINE-TO MEDIUM-GRAINED SAND, 15% SILT
- SP YELLOW SAND (SP) (10YR7/6) LOOSE, MOIST, 95% FINE-TO MEDIUM-GRAINED SAND, 5% SILT
- FILL GLASS SHARDS, CHARRED WOOD, WINDOW SCREENS, SCRAP METAL, SPRINGS, NAILS

NO SOIL OVA READINGS TAKEN OR DETECTED

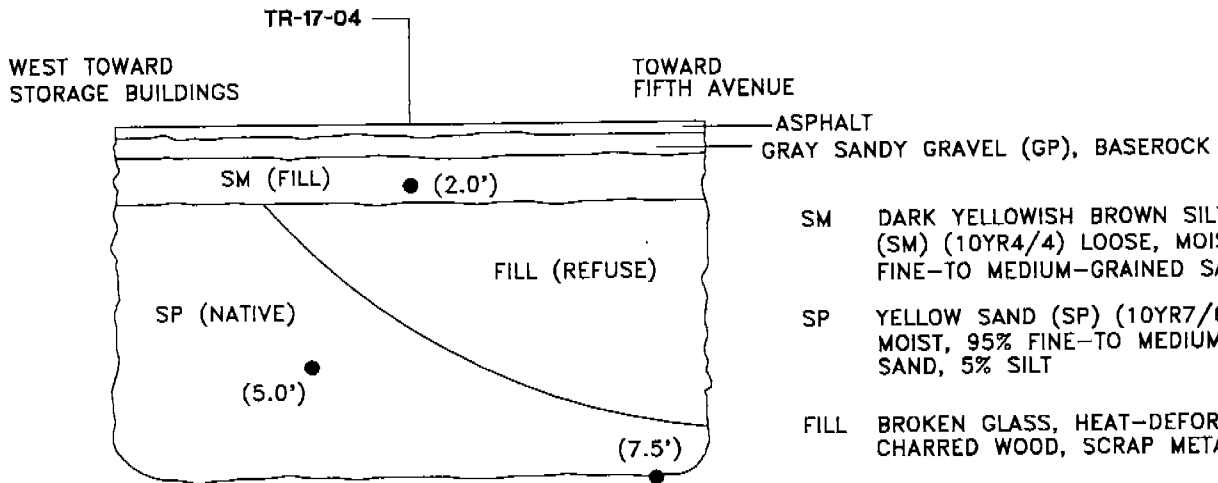

- SM DARK YELLOWISH BROWN SILTY SAND (SM) (10YR4/4) LOOSE, MOIST, 85% FINE-TO MEDIUM-GRAINED SAND, 15% SILT
- SP YELLOW SAND (SP) (10YR7/6) LOOSE, MOIST, 95% FINE-TO MEDIUM-GRAINED SAND, 5% SILT
- FILL BROKEN GLASS, HEAT-DEFORMED GLASS, CHARRED WOOD, SCRAP METAL

NO SOIL OVA READINGS TAKEN OR DETECTED

EXPLANATION

● TRENCH SAMPLE LOCATION

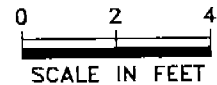

Harding Lawson Associates
Engineering and Environmental Services

Exploratory Trenches - TR-17-03 and TR-17-04
Site 17 - 1400 Block Motor Pool and Suspected Disposal Area
Site Characterization
Fort Ord, California

PLATE

A43

DRAWN PROJECT NUMBER
YG 23366 041711

APPROVED

83

DATE
4/93

REVISED DATE

7579132 2.0

TR-17-05
 TOWARD FIFTH AVENUE
 WEST TOWARD STORAGE BUILDINGS

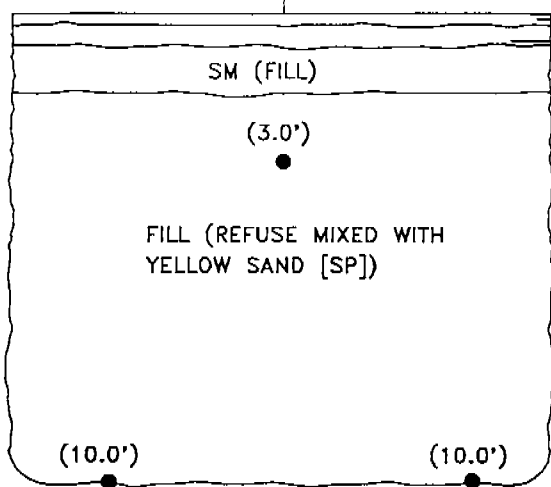

ASPHALT
 GRAY SANDY GRAVEL (GP), BASEROCK

SM DARK YELLOWISH BROWN SILTY SAND (SM) (10YR4/4) LOOSE, MOIST

FILL PREDOMINANTLY OLD BOTTLES, NEWSPAPER (MARCH 1, 1950), NYLONS, CANS, SCRAP METAL, CHARRED WOOD, BROOM HANDLES. LAYERED WITH YELLOW SAND (SP) APPROXIMATELY 1' TWO LAYERS

NO SOIL OVA READINGS DETECTED. ONE READING OF 10ppm DETECTED INSIDE LIQUOR BOTTLE

EXPLANATION

● TRENCH SAMPLE LOCATION

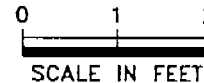

Harding Lawson Associates
 Engineering and Environmental Services

Exploratory Trench - TR-17-05
 Site 17 - 1400 Block Motor Pool and Suspected Disposal Area
 Site Characterization
 Fort Ord, California

PLATE

A44

DRAWN PROJECT NUMBER
 YG 23366 041711

APPROVED
Rfm

DATE
 4/93

REVISED DATE

7579133 20
 19930401.1010

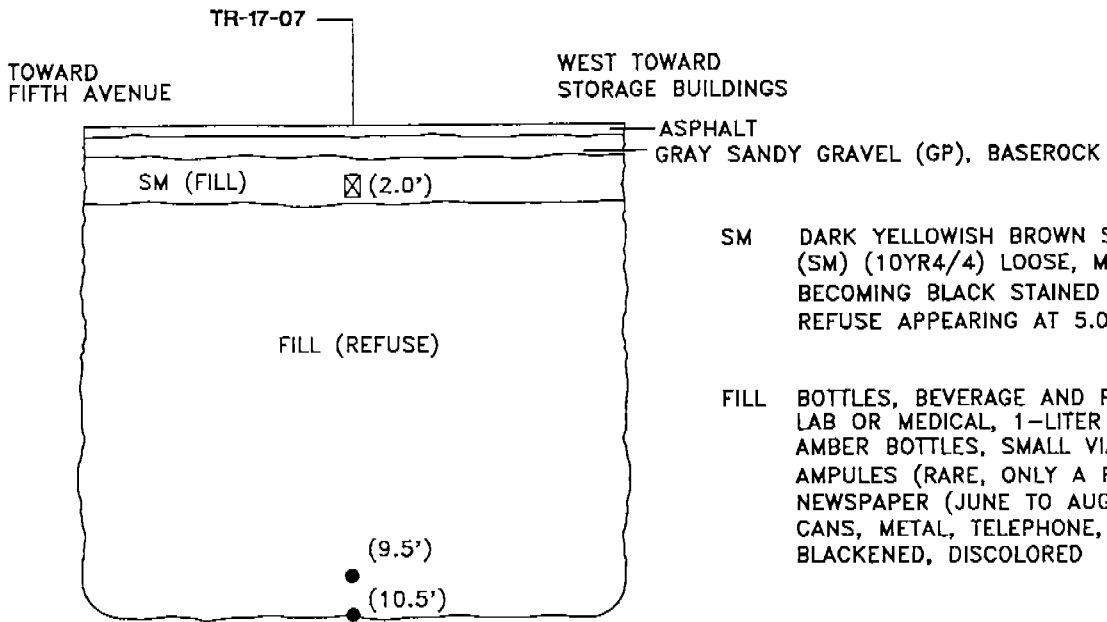

- SM DARK YELLOWISH BROWN SILTY SAND (SM) (10YR4/4) LOOSE, MOIST, BECOMING BLACK STAINED AT 4.5', REFUSE APPEARING AT 5.0'
- FILL BOTTLES, BEVERAGE AND POSSIBLE LAB OR MEDICAL, 1-LITER CLEAR GLASS AND AMBER BOTTLES, SMALL VIALS AND AMPULES (RARE, ONLY A FEW), LUMBER, NEWSPAPER (JUNE TO AUGUST 1949), CANS, METAL, TELEPHONE, BOOT, BLACKENED, DISCOLORED

MAXIMUM OVA = 100 ppm

EXPLANATION

● TRENCH SAMPLE LOCATION



Harding Lawson Associates
Engineering and Environmental Services

Exploratory Trench TR-17-07
Site 17 - 1400 Block Motor Pool and Suspected Disposal Area
Site Characterization
Fort Ord, California

PLATE

A45

DRAWN
YG

PROJECT NUMBER
23366 041711

APPROVED
RFM

DATE
4/93

REVISED DATE

1579134 20
19930409.1106

Test Pit #: TR-17-08
 Date Started: 8-23-93
 Date Completed: 8-24-93
 Orientation: N41E
 Elevation:

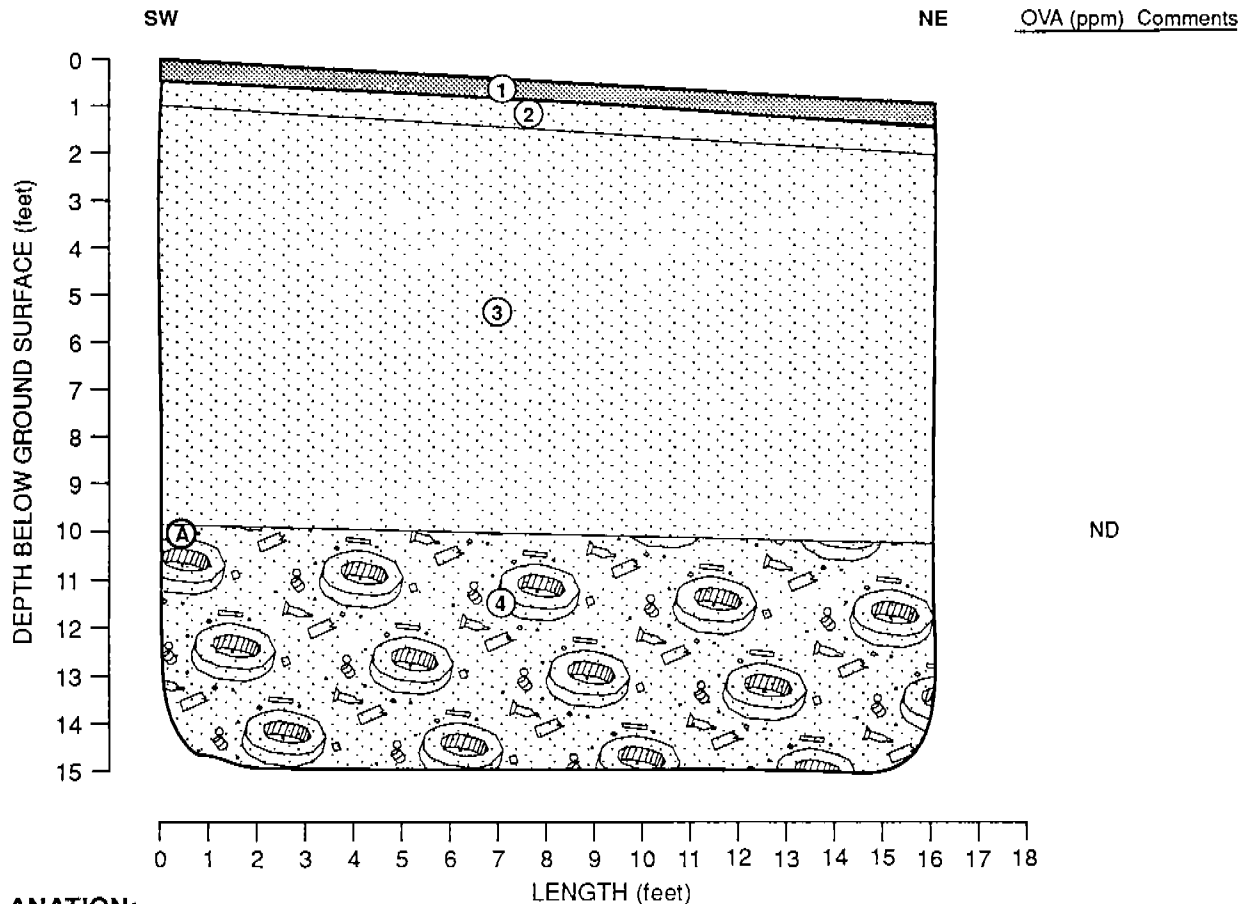

EXPLANATION:

- ① ASPHALT AND BASEROCK
- ② DARK BROWN SAND (SP) (10YR 3/3), loose, moist, fine to medium sand, 0-5% silt, fill
- ③ VERY DARK GRAYISH BROWN AND DARK YELLOWISH BROWN SAND (SP) (10YR 3/2 and 10YR 4/6), loose, moist, fine to medium sand, 0-5% silt, laminations/bedding up to 3" thick, trace debris (metal pipe at 2 feet, Coke bottle [1946] and wood at 6 feet, mess kit lid [1942]), fill, laminated, bedded
- ④ LAYERED SAND AND DEBRIS - DARK BROWN SAND (SP) (10YR 3/3), loose, moist, fine to medium sand, 5-10% silt, debris layers (40%-60% debris) vary from 2" to 1 foot thick and include soda/beer cans, wood ammo boxes, half filled medical bottles, bleach bottles, wooden pallets, shoes, nylons, paper, "dank" can, bottle dates: 1935 (catsup bottle), 1946, 1947 (cola bottles), and 1949 (medical bowl or cup), fill
- Ⓐ SAMPLE: 9334017A066F

071294AG



Harding Lawson Associates
 Engineering and
 Environmental Services

Log of Test Pit TR-17-08
 Site 17-Disposal Area
 Volume II - RI, Basewide RI/FS
 Fort Ord, California

PLATE

A46

DRAWN: DJPc
 JOB NUMBER: 23366 041711

APPROVED: *Rfm*

DATE: 11/93

REVISED DATE

Test Pit #: TR-17-09
 Date Started: 8-23-93
 Date Completed: 8-24-93
 Orientation: N6E
 Elevation:

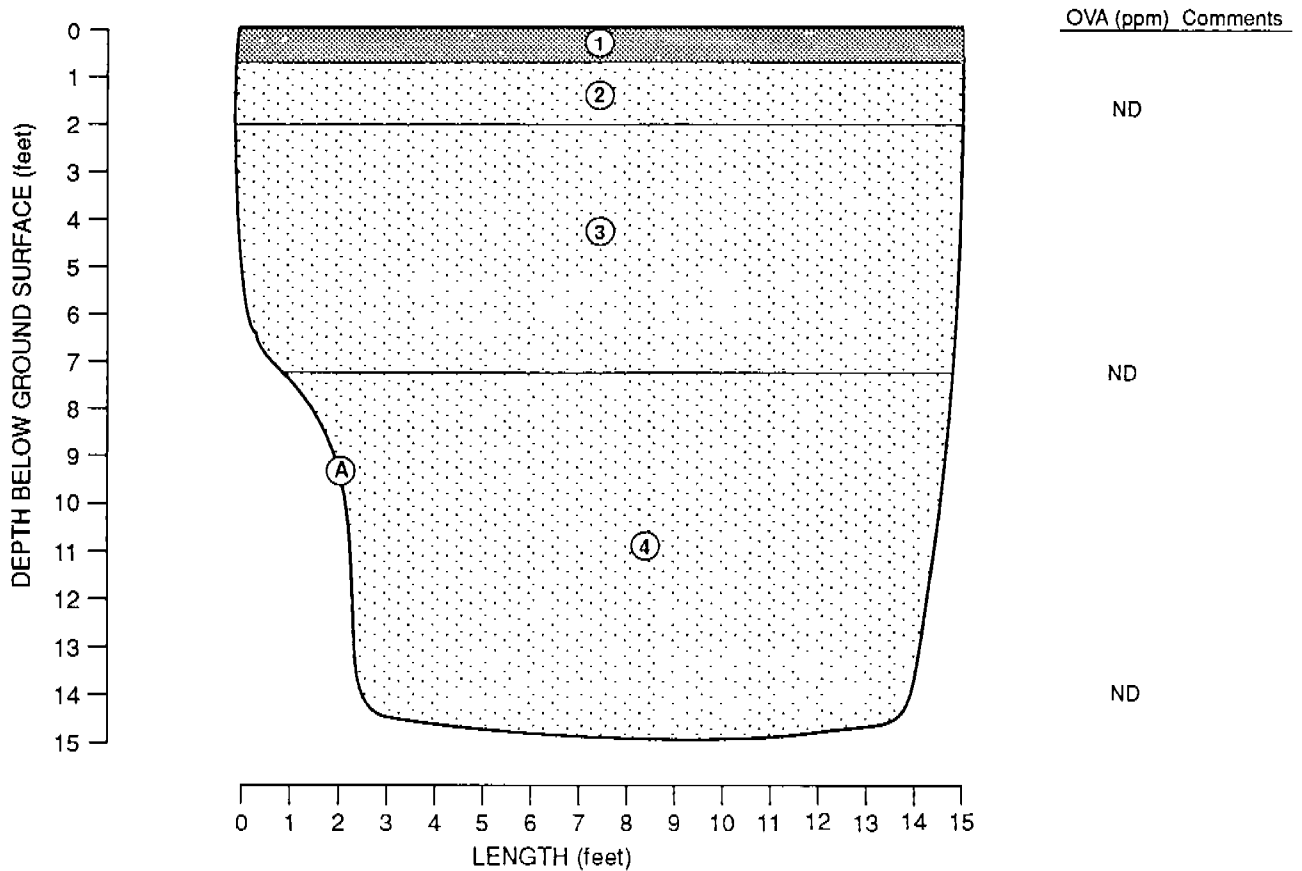

EXPLANATION:

- ① ASPHALT AND BASEROCK, 4" asphalt, 4" baserock
- ② STRONG BROWN AND DARK BROWN SAND (SP) (7.5 YR 4/6 and 7.5 YR 3/3), loose, moist, fine to medium sand, 0-5% silt, upper 4-5" is strong brown and lower 6-7" is dark brown, fill
- ③ DARK BROWN AND YELLOWISH BROWN SAND (SP) (10YR 3/3 and 10YR 5/6), loose, moist, fine to medium sand, 0-5% silt, alternating beds and laminations, trace debris (boot heel) at 6', fill
- ④ DARK BROWN SAND (SP) (10YR 3/3), loose, moist, fine to medium sand, 0-5% silt, trace debris (wire, wood, and rock) present to 12 feet, fill
- Ⓐ 9334017A065F

041294LZ



Harding Lawson Associates
 Engineering and
 Environmental Services

Log of Test Pit TR-17-09
 Site 17-Disposal Area
 Volume II - RI, Basewide RI/FS
 Fort Ord, California

PLATE

A47

DRAWN: DJPc
 JOB NUMBER: 23366 041711

APPROVED: RFM

DATE: 11/93

REVISED DATE

Test Pit #: TR-17-10
 Date Started: 8-23-93
 Date Completed: 8-24-93
 Orientation: N
 Elevation:

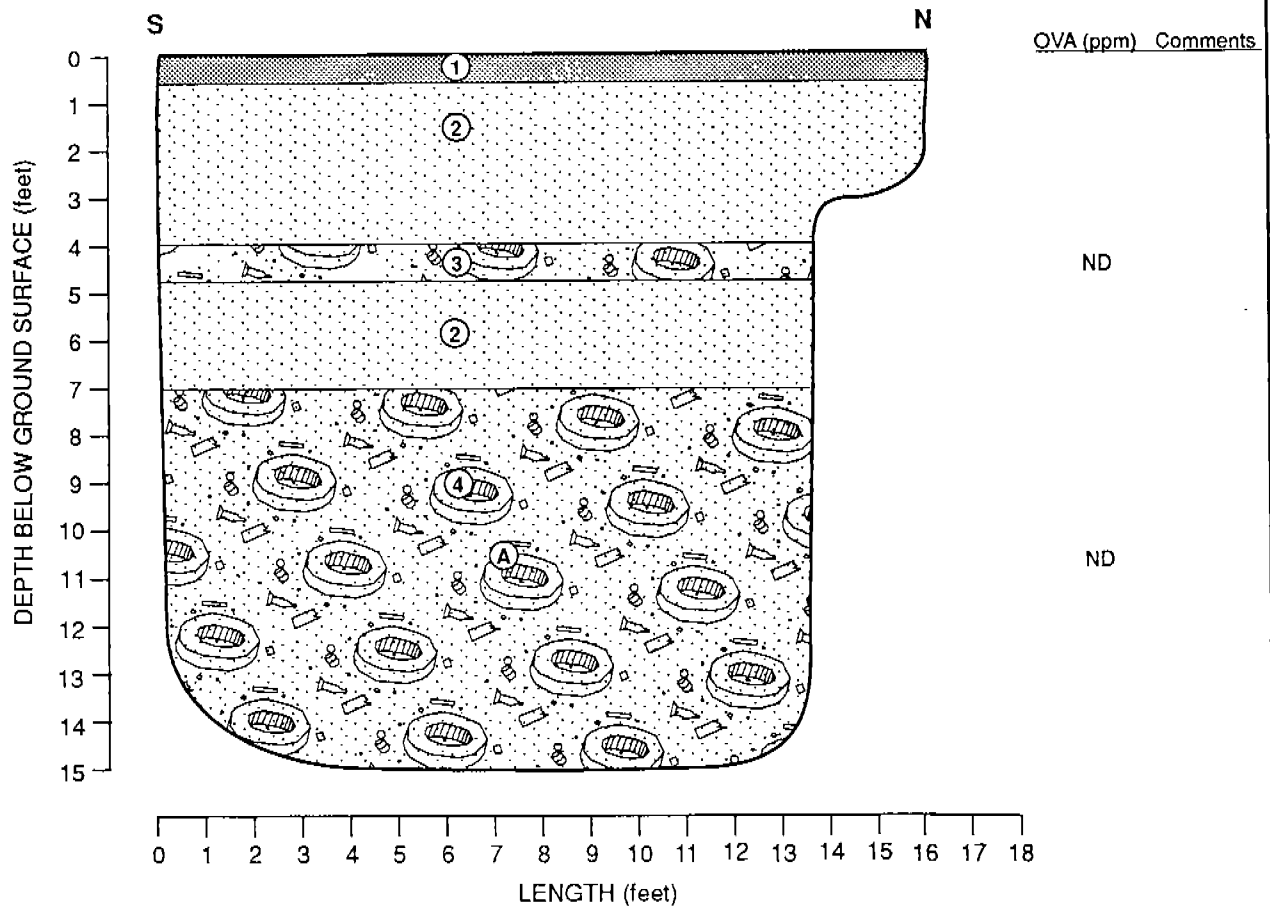

EXPLANATION:

- ① ASPHALT AND BASEROCK, 4" asphalt, 4" baserock
- ② DARK BROWN AND DARK YELLOWISH BROWN SAND (SP)(10YR 3/3 & 10YR 4/6), loose, moist, fine to medium sand, 0-5% silt, alternating laminations/beds 4" to 1' thick, trace debris (at 1.5 feet, shoe lace, plate fragment, broken glass), fill
- ③ METAL DEBRIS LAYER, DARK BROWN SAND (SP) (10YR 3/3), 30-50% metal debris (rusted tin, steel), fill
- ④ DEBRIS LAYER AND VERY DARK GRAYISH BROWN SAND (SP) (10YR 3/2), very loose, moist, fine to medium sand, 5% silt, 35-45% debris (glass, tin cans, boots, metal, wood, medical waste, 1951 glass jar, cold cream/shampoo jars, 1949 Coke bottle, boot), less debris, if present, below 12 feet, fill
- Ⓐ SAMPLE: 9334017A064F

041294LZ



Harding Lawson Associates
 Engineering and
 Environmental Services

Log of Test Pit TR-17-10
 Site 17-Disposal Area
 Volume II - RI, Basewide RI/FS
 Fort Ord, California

PLATE

A48

DRAWN DJPC	JOB NUMBER 23366 041711	APPROVED RFM	DATE 11/93	REVISED DATE
---------------	----------------------------	-----------------	---------------	--------------

Test Pit #: TR-17-11
 Date Started: 8-24-93
 Date Completed: 8-24-93
 Orientation: N1W
 Elevation:

OVA (ppm) Comments

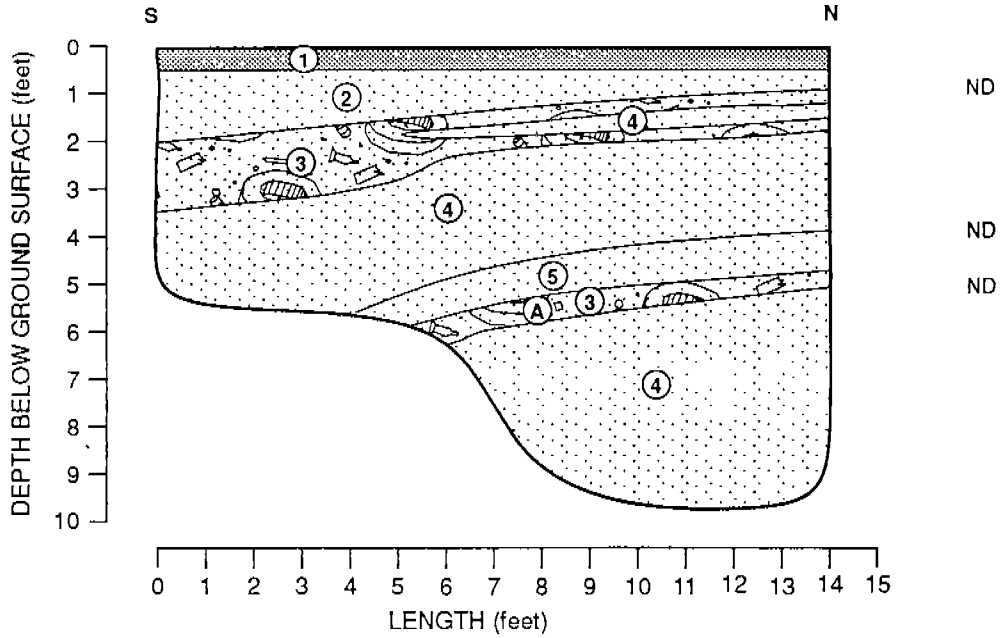

- EXPLANATION:**
- ① ASPHALT AND BASEROCK, 3" asphalt, 3" asphalt baserock
 - ② DARK BROWN SAND (SP) (10YR 3/3), loose, moist, fine to medium sand, 5% silt, with discontinuous light yellowish brown (10YR 6/4) sand lens, fill
 - ③ DEBRIS LAYER AND SAND 40 to 60% debris, 40-60% light yellowish brown sand (SP) (10YR 6/4), loose, dry, fine to medium sand, debris includes rusted metal, glass bottles, Coke bottles (1941, 1948, 1949), test tube, syringe, vial with cotton ball in the bottom, cans, "dank" can, vials, light bulb, fill
 - ④ LIGHT YELLOWISH BROWN SAND (SP) (10YR 6/4), loose, dry, fine to medium sand, fill
 - ⑤ DARK BROWN SAND (SP) (10YR 3/3), loose, dry, fine to medium sand, 5% silt
 - (A) 9334017A067F

071294AG



Harding Lawson Associates
 Engineering and
 Environmental Services

Log of Test Pit TR-17-11
 Site 17-Disposal Area
 Volume II - RI, Basewide RI/FS
 Fort Ord, California

PLATE

A49

DRAWN: DJP
 JOB NUMBER: 23366 041711

APPROVED: RFM

DATE: 11/93

REVISED DATE

Test Pit #: TR-17-12
 Date Started: 8-24-93
 Date Completed: 8-25-93
 Orientation: N86E
 Elevation:

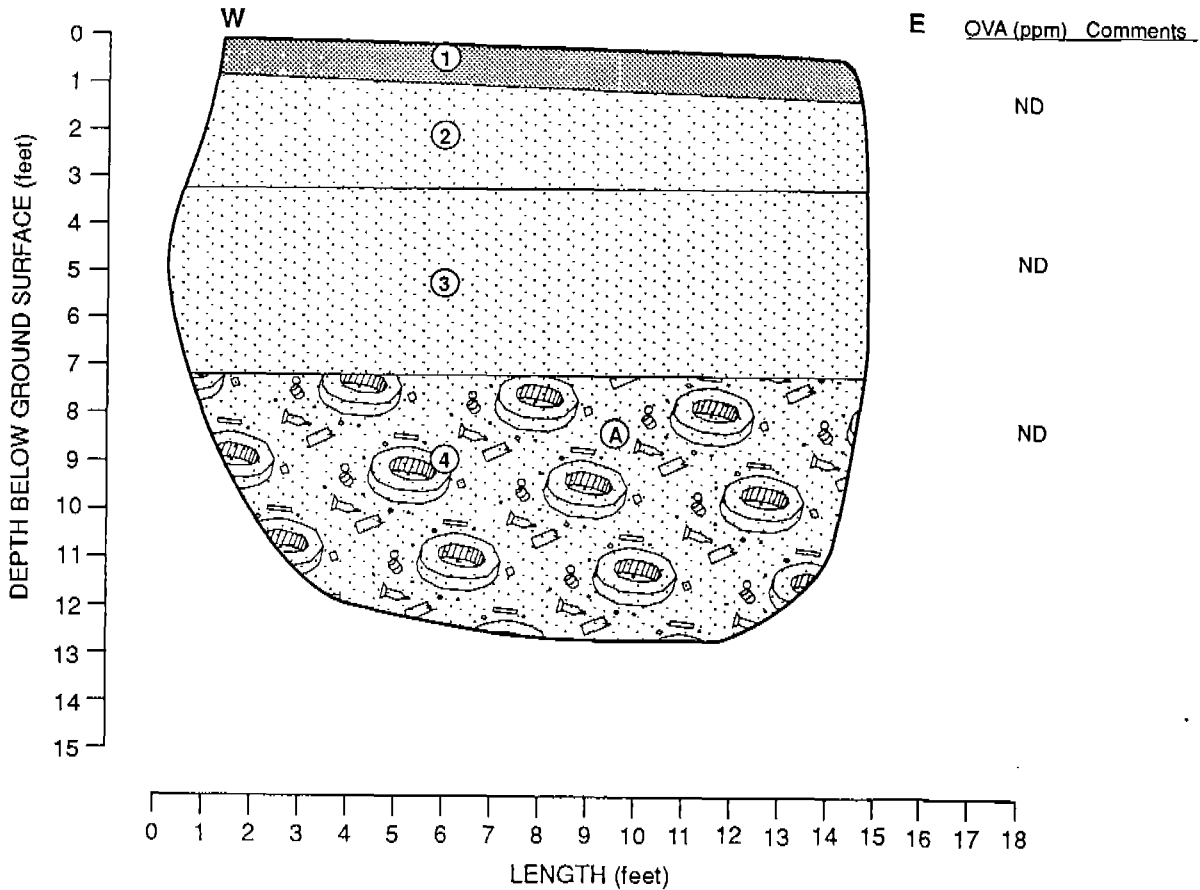

EXPLANATION:

- ① ASPHALT AND BASEROCK, 4" ASPHALT, 9" BASEROCK
- ② BROWN AND YELLOWISH BROWN SAND (SP) (10YR 4/3 & 10YR 5/6), very loose, moist, fine to medium sand, 0-5% silt
- ③ DARK BROWN, BROWN, DARK YELLOWISH BROWN AND YELLOWISH BROWN SAND (SP) (10YR 3/3, 10YR 4/3, 10YR 4/6 & 10YR 5/6), loose, moist, fine to medium sand, 0-10% silt, laminated fill
- ④ DARK BROWN SAND (SP) (10YR 3/3), very loose, moist, fine to medium sand, 5-10% silt, 35%-40% debris consisting of wood, metal (cans, drum lid, pipe, wire, coffee pot), glass (1947 Coke bottle, beer bottles, old spice bottle, Pepto Bismal bottle complete with pink fluid), comb, newspaper (no date), fill

Ⓐ SAMPLE: 9334017A068F

032494DJP



Harding Lawson Associates
 Engineering and Environmental Services

Log of Test Pit TR-17-12
 Site 17-Disposal Area
 Volume II - RI, Basewide RI/FS
 Fort Ord, California

PLATE

A50

DRAWN
DJPc

JOB NUMBER
23366 041711

APPROVED
RFM

DATE
10/93

REVISED DATE

Test Pit #: TR-17-13
 Date Started: 8-25-93
 Date Completed: 8-25-93
 Orientation: N85W
 Elevation:

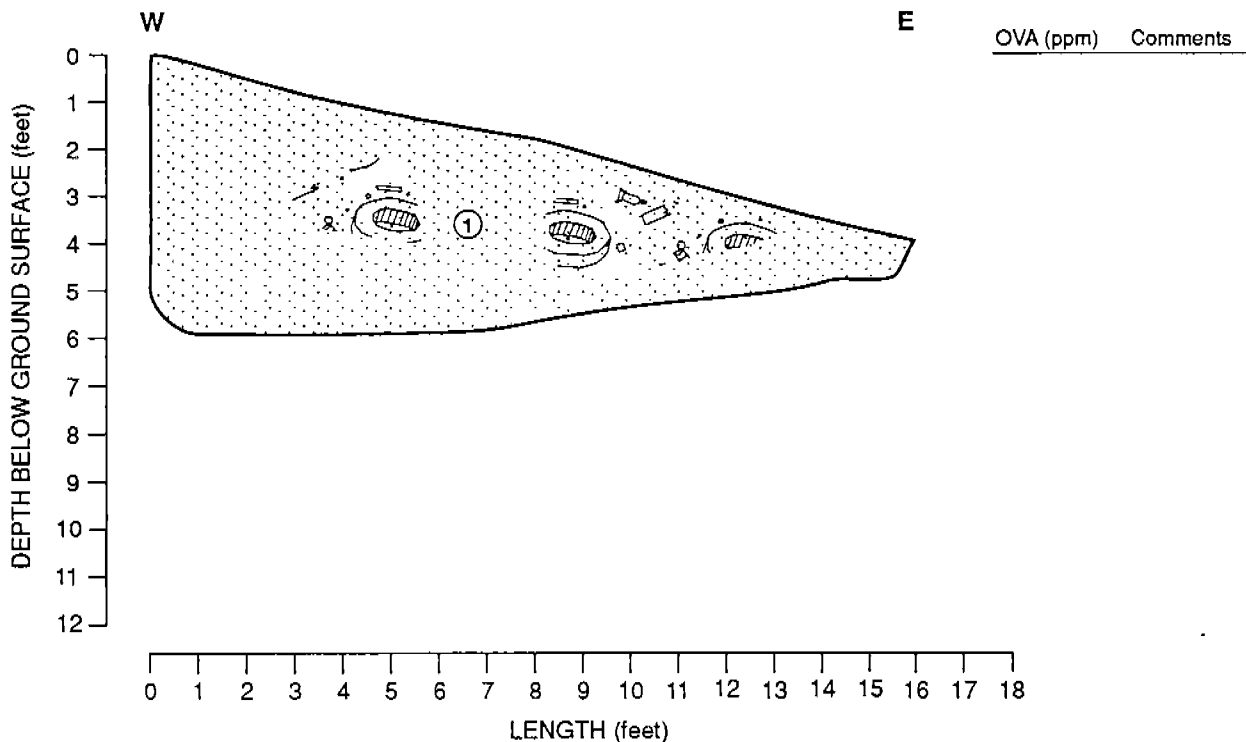

EXPLANATION:



VERY DARK GRAYISH BROWN SAND (SP) (10YR 3/2), very loose, moist, fine to medium sand, 3-10% silt, localized debris make-up trace to 10%, debris includes concrete chunks, metal pans, nylons, beer bottle, light bulb (G.E. 2400), glass jars and metal hinge, fill

Note: Test pit was halted due to concern of possible utility lines and was logged after the test pit was partially backfilled; the limits of the debris was not defined.

071294AG

PLATE



Harding Lawson Associates
 Engineering and
 Environmental Services

Log of Test Pit TR-17-13
 Site 17-Disposal Area
 Volume II - RI, Basewide RI/FS
 Fort Ord, California

A51

DRAWN	JOB NUMBER	APPROVED	DATE	REVISED DATE
DJpc	23366 041711	<i>RFM</i>	10/93	

Test Pit #: TR-17-14
 Date Started: 8-25-93
 Date Completed: 8-26-93
 Orientation: N87W
 Elevation:

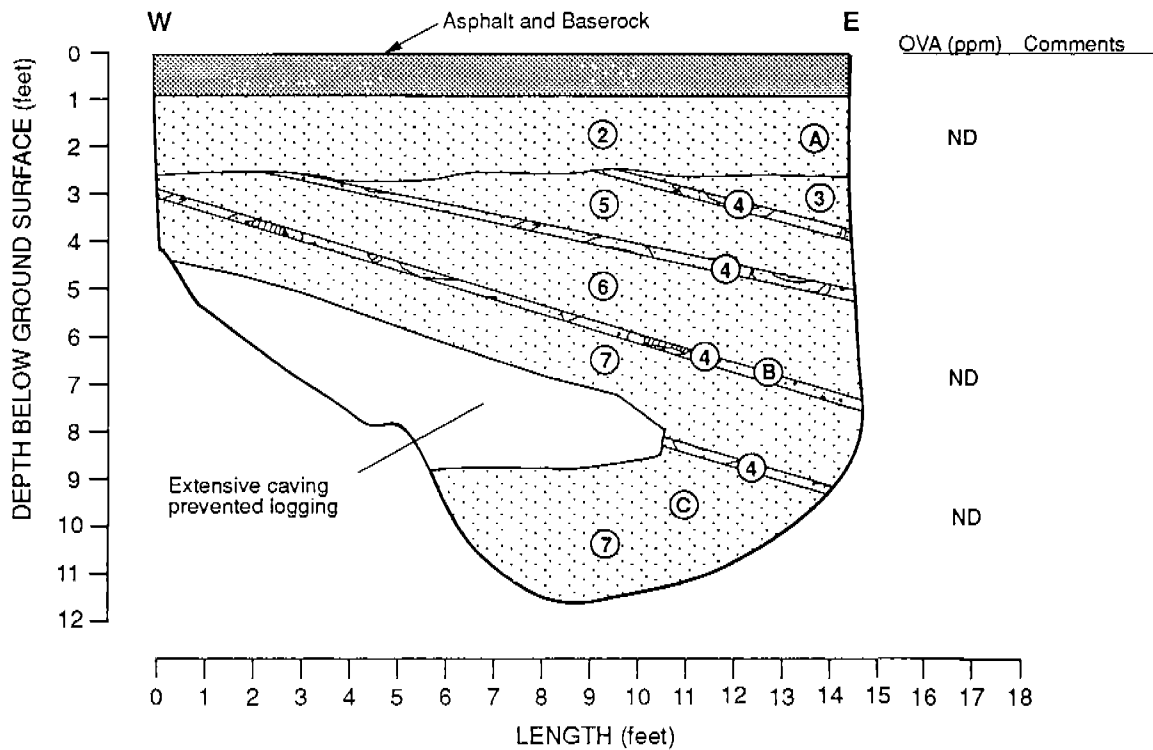

EXPLANATION:

- ① ASPHALT AND BASEROCK
- ② DARK GRAYISH BROWN SAND (SP) (10YR 3/2), loose, moist, fine to medium sand, trace silt, fill
- ③ BROWN SAND (SP) (10YR 4/3), very loose, dry, fine to medium sand, trace to 10% silt, fill
- ④ DEBRIS LAYER (>50%) including medical vials with stoppers, metal cans, milk bottles, Coke bottles (1940, 1944, 1946, and 1947), Belfast bottles (1949), hand crank wench, fill
- ⑤ YELLOWISH BROWN SAND (SP) (10YR 5/6), very loose, dry, fine to medium sand, 0-5% silt, fill
- ⑥ DARK BROWN AND YELLOWISH BROWN SAND (SP) (10YR 3/3 & 10YR 5/6), very loose, moist, fine to medium sand, 0-5% silt, laminated, fill
- ⑦ DARK BROWN SAND (SP) (10YR 3/3), very loose, moist, fine to medium sand, 5-10% silt, possibly undisturbed below last debris layer, less loose at depth

- (A) SAMPLE: 9334017A070F
- (B) SAMPLE: 9334017A071F
- (C) SAMPLE: 9334017A072F

071294AG



Harding Lawson Associates
 Engineering and
 Environmental Services

Log of Test Pit TR-17-14
 Site 17-Disposal Area
 Volume II - RI, Basewide RI/FS
 Fort Ord, California

PLATE

A52

DRAWN: DJP
 JOB NUMBER: 23366 041711

APPROVED: RFM

DATE: 11/93

REVISED DATE:

Test Pit #: TR-17-15
 Date Started: 8-25-93
 Date Completed: 8-27-93
 Orientation: N62W
 Elevation:

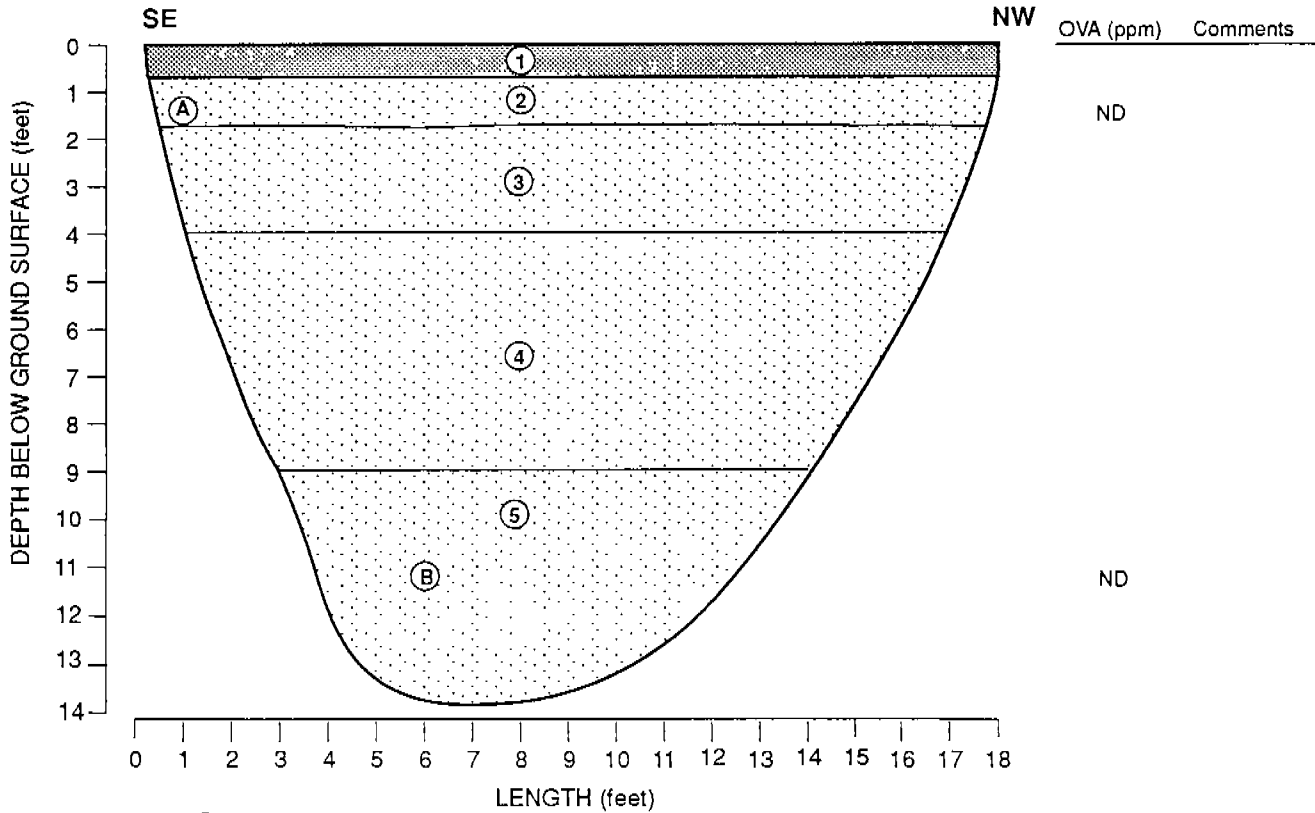

EXPLANATION:

- ① ASPHALT AND BASEROCK
- ② BROWN, YELLOWISH BROWN & DARK BROWN SAND (SP) (10YR 4/2, 10YR 5/6 & 10YR 3/3), very loose, moist, fine to medium sand, 0-10% silt, compacted fill is in 3-4" lifts in color order, fill
- ③ BROWN AND YELLOWISH BROWN SAND (SP) (10YR 4/3 & 10YR 5/6), very loose, moist, fine to medium sand, 0-10% silt, laminated, fill
- ④ BROWN SAND (SP) (10YR 4/3), loose, moist, fine to medium sand, trace to 10% silt, trace debris (Coke bottles [1947], steel cable, chunks of concrete), fill
- ⑤ DARK BROWN SAND (SP) (10YR 3/3), loose, moist, fine to medium sand, trace to 10% silt
- Ⓐ SAMPLE: 9334017A074F
- Ⓑ SAMPLE: 9334017A073F

071294AG



Harding Lawson Associates
 Engineering and
 Environmental Services

Log of Test Pit TR-17-15
 Site 17-Disposal Area
 Volume II - RI, Basewide RI/FS
 Fort Ord, California

PLATE

A53

DRAWN: DJPc
 JOB NUMBER: 23366 041711

APPROVED: RFM

DATE: 10/93

REVISED DATE

Test Pit #: TR-17-16
 Date Started: 8-26-93
 Date Completed: 8-27-93
 Orientation: E-W
 Elevation:

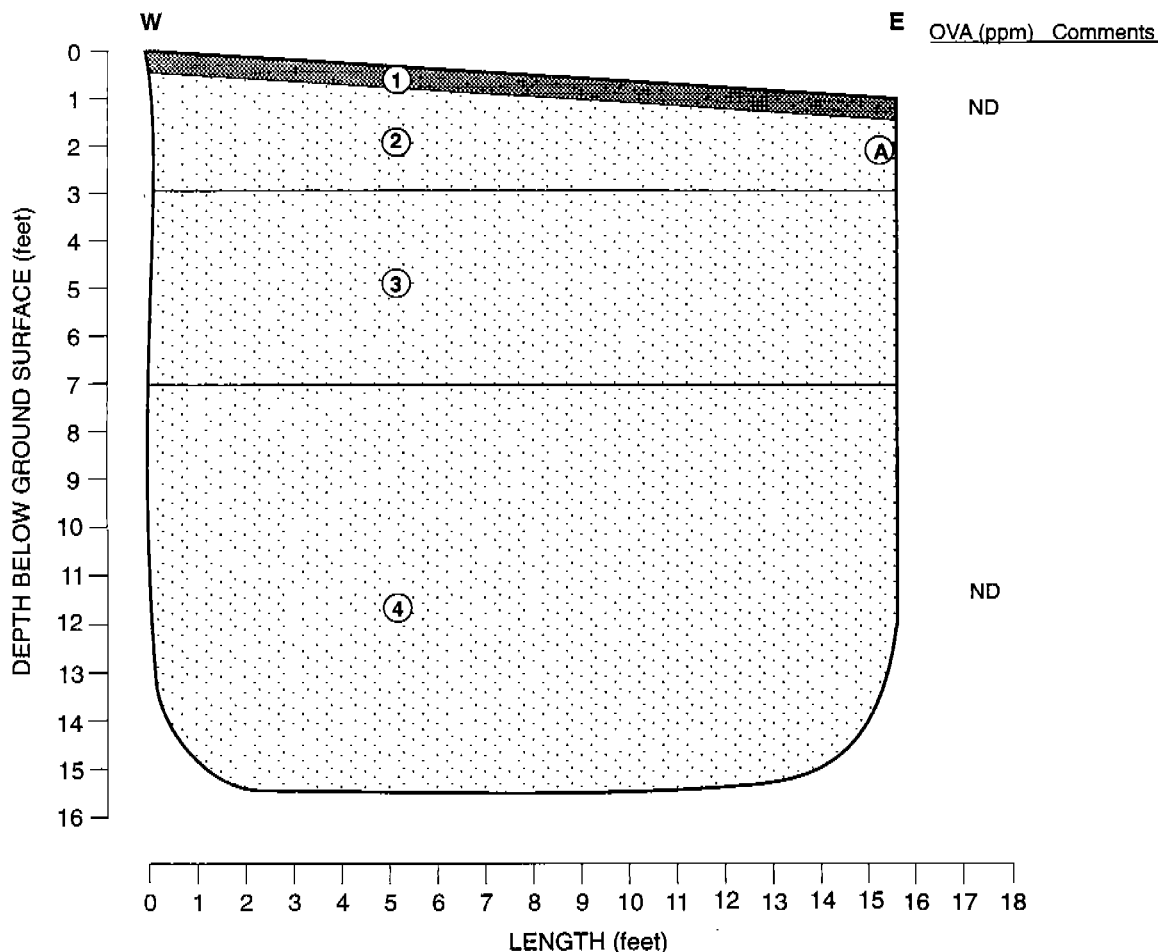

EXPLANATION:

- ① ASPHALT AND BASEROCK
- ② VERY DARK GRAYISH BROWN SAND (SP) (10YR 3/2), very loose, moist, fine to medium sand, trace to 10% silt, fill
- ③ STRATIFIED YELLOWISH BROWN AND BROWN SAND (SP) (10YR 5/6 & 10YR 4/3), very loose, moist, fine to medium sand, 0-10% silt
- ④ BROWN SAND (SP) (10YR 4/3), very loose, moist, fine to medium sand, trace to 10% silt
- Ⓐ SAMPLE: 9334017A07F

071294AG



Harding Lawson Associates
 Engineering and
 Environmental Services

Log of Test Pit TR-17-16
 Site 17-Disposal Area
 Volume II - RI, Basewide RI/FS
 Fort Ord, California

PLATE

A54

DRAWN DJPC	JOB NUMBER 23366 041711	APPROVED <i>RFA</i>	DATE 10/93	REVISED DATE
---------------	----------------------------	------------------------	---------------	--------------

Test Pit #: TR-17-17
 Date Started: 8-26-93
 Date Completed: 8-27-93
 Orientation: N59W
 Elevation:

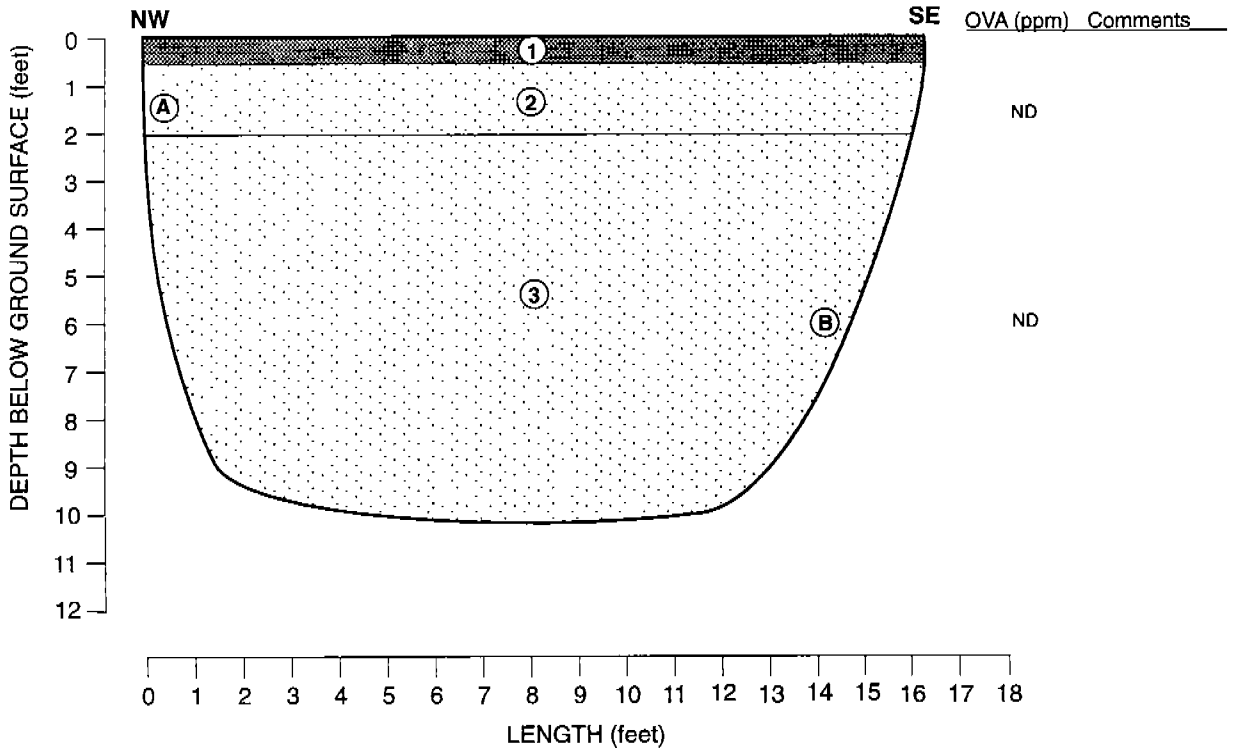

EXPLANATION:

- 1 ASPHALT AND BASEROCK
- 2 DARK BROWN SAND (SP) (10YR 3/3)
 loose, moist, fine to medium sand, trace to 10%
 silt, fill
- 3 YELLOWISH BROWN SAND (SP) (10YR 5/6)
 very loose, moist, fine to medium sand
- A SAMPLE: 9334017A085F
- B SAMPLE: 9334017A086F

071294AG



Harding Lawson Associates
 Engineering and
 Environmental Services

Log of Test Pit TR-17-17
 Site 17-Disposal Area
 Volume II - RI, Basewide RI/FS
 Fort Ord, California

PLATE

A55

DRAWN: DJPc
 JOB NUMBER: 23366 041711

APPROVED: *RFM*

DATE: 10/93

REVISED DATE

Test Pit #: TR-17-18
 Date Started: 2-22-94
 Date Completed: 2-22-94
 Orientation: N5E
 Elevation:

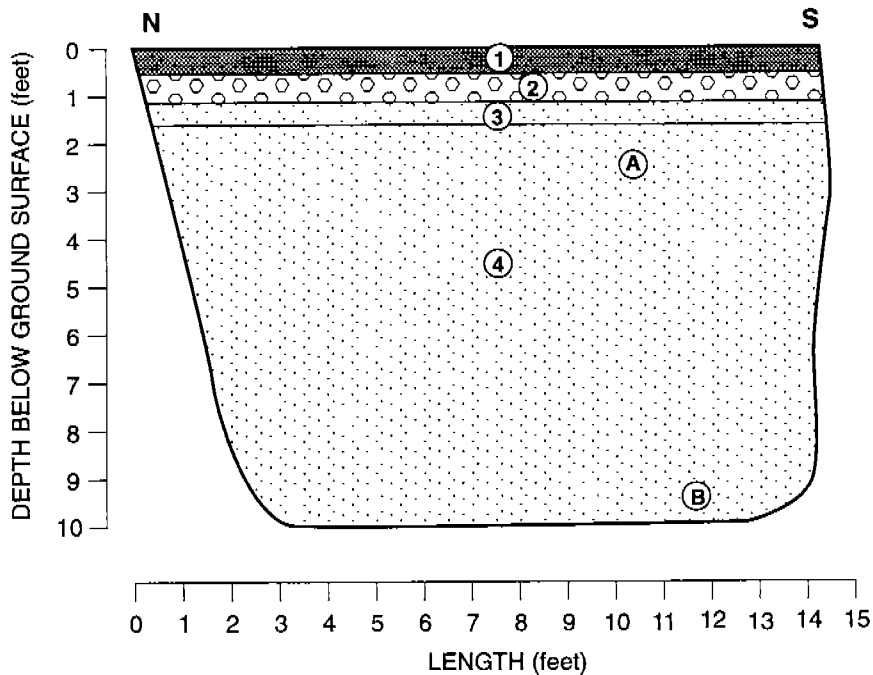

OVA (ppm) Comments

ND

ND

ND

EXPLANATION:

- ① ASPHALT
- ② OLIVE GRAVEL WITH SAND (GP) (5Y 5/3), dense, moist, subangular fine gravel, 15% fine sand
- ③ DARK YELLOWISH BROWN SAND (SP) (10YR 3/6), medium dense, moist, fine sand
- ④ BROWNISH YELLOW SAND (SP) (10YR 6/6), loose, moist, fine to medium sand
- Ⓐ SAMPLE: 9408G017079F
- Ⓑ SAMPLE: 9408G017081F

071394AG

PLATE



Harding Lawson Associates
 Engineering and
 Environmental Services

Log of Test Pit TR-17-18
 Site 17-Disposal Area
 Volume II - RI, Basewide RI/FS
 Fort Ord, California

A56

DRAWN
LZc

JOB NUMBER
23366 041711

APPROVED
RFM

DATE
4/94

REVISED DATE

Test Pit #: TR-17-19
 Date Started: 2-23-94
 Date Completed: 2-23-94
 Orientation: N10E
 Elevation:

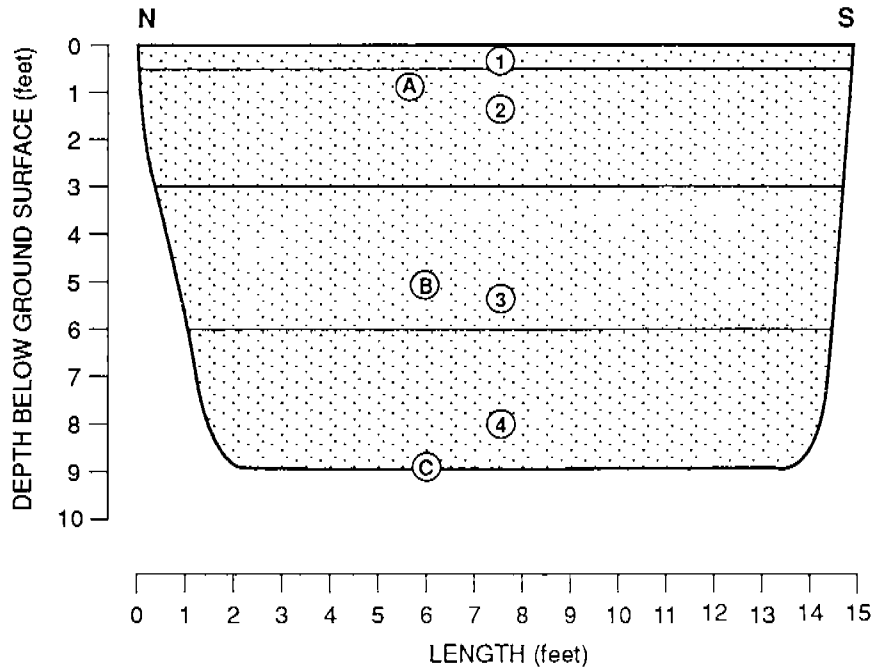

OVA (ppm)	Comments
ND	
ND	
ND	

EXPLANATION:

- ① DARK BROWN SAND (SP) (10YR 3/3), loose, dry, fine to medium sand
- ② DARK YELLOWISH BROWN SAND (SP) (10YR 4/6), loose, dry, fine to medium sand
- ③ YELLOWISH BROWN SAND (SP) (10YR 3/6), medium dense, moist, fine to medium sand
- ④ YELLOWISH BROWN SAND (SP) (10YR 3/6), medium dense, moist, fine to medium sand

- Ⓐ SAMPLE: 9408Y017002F
- Ⓑ SAMPLE: 9408Y017003F
- Ⓒ SAMPLE: 9408Y017004F

0504DJP

PLATE



Harding Lawson Associates
 Engineering and
 Environmental Services

Log of Test Pit TR-17-19
 Site 17-Disposal Area
 Volume II - RI, Basewide RI/FS
 Fort Ord, California

A57

DRAWN: LZc
 JOB NUMBER: 23366 041711

APPROVED: *rfm*

DATE: 4/94

REVISED DATE

Test Pit #: TR-17-20
 Date Started: 2-23-94
 Date Completed: 2-23-94
 Orientation: N12E
 Elevation:

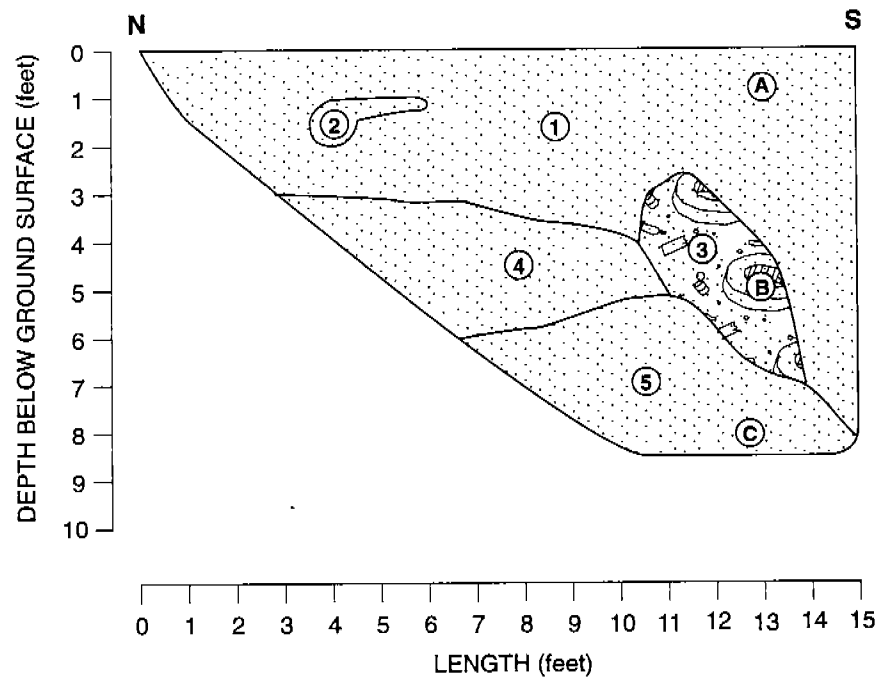

OVA (ppm)	Comments
ND	
ND	
ND	
ND	

EXPLANATION:

- ① DARK BROWN SAND (SP) (7.5YR 3/4), loose, moist, fine sand
- ② DARK GRAY SAND (SP) (10YR 4/1), moist, fine sand
- ③ DARK YELLOWISH BROWN SAND WITH DEBRIS
 loose, moist, fine sand, 15% debris (pieces of tin cans, bottles, serum bottles [*medical waste], gauze, partially burnt cardboard, hangers, shoe frame?)
- ④ YELLOWISH BROWN SAND (SP) (10YR 5/6), moist, fine sand
- ⑤ YELLOW SAND (SP) moist, fine sand
- Ⓐ SAMPLE: 9408G017082F
- Ⓑ SAMPLE: 9408G017083F
- Ⓒ SAMPLE: 9408G017085F

071394AG



Harding Lawson Associates
 Engineering and
 Environmental Services

Log of Test Pit TR-17-20
 Site 17-Disposal Area
 Volume II - RI, Basewide RI/FS
 Fort Ord, California

PLATE

A58

DRAWN	JOB NUMBER	APPROVED	DATE	REVISED DATE
LZc	23366 041711	RFM	4/94	

Test Pit #: TR-17-21
 Date Started: 2-24-94
 Date Completed: 2-24-94
 Orientation: N82E
 Elevation:

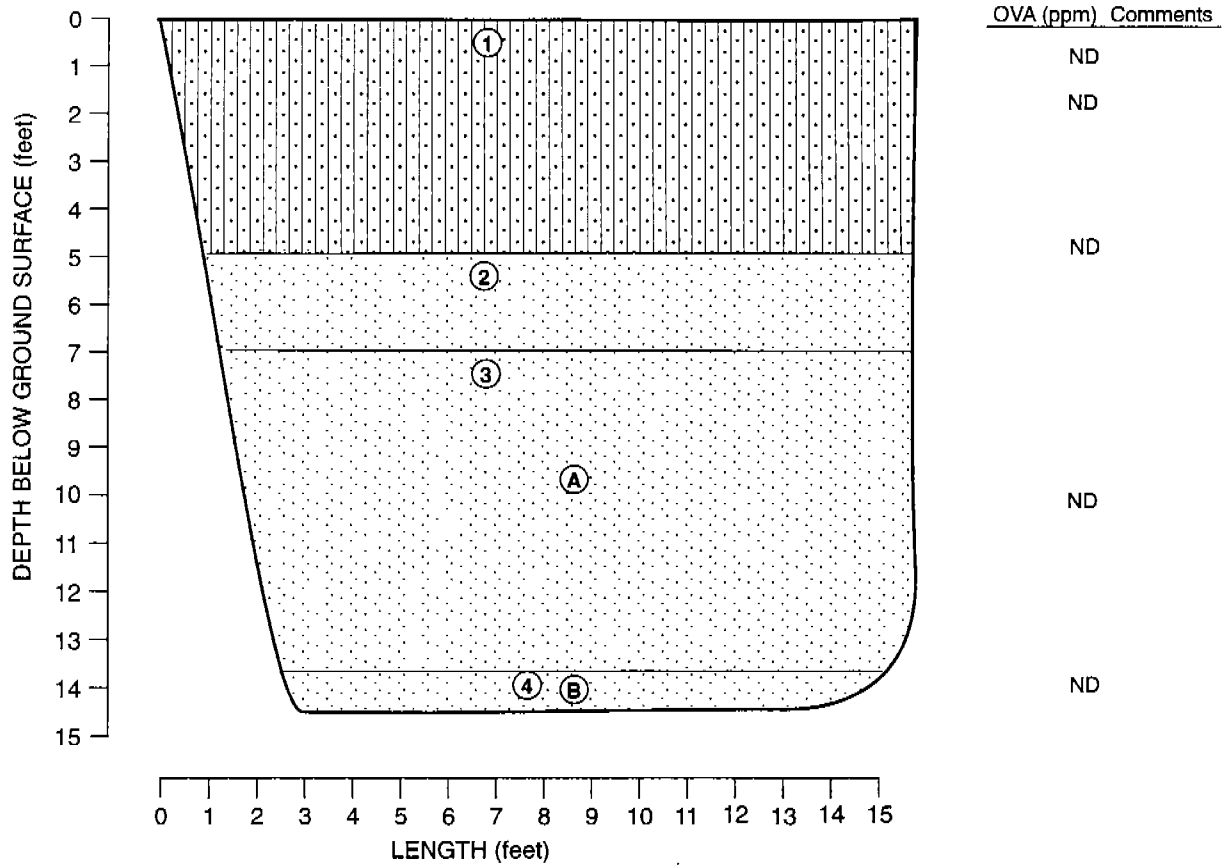

EXPLANATION:

- ① DARK BROWN SILTY, SAND (SM) 10YR 3/3, loose, moist, medium sand, 15% silt, vegetation at surface, some roots at 1 to 1.5 ft, a drum ring (rusted), wood pieces, glass pieces from 1 to 1.5 feet
- ② YELLOWISH BROWN SAND (SP) 10YR 3/6, medium dense, moist, medium to fine sand
- ③ DARK BROWN SAND (SP) 10YR 3/3, medium dense, moist, medium to fine sand, 0-5% debris (wood, bottles, broken glass, ceramic bottles, rubber soles) observed, but intermittent and not continuous
- ④ YELLOWISH BROWN SAND (SP) 10Y3/6, medium dense, moist, medium to fine sand
- Ⓐ 9408Y017008F
- Ⓑ 9408Y017009F

071394AG

PLATE



Harding Lawson Associates
 Engineering and
 Environmental Services

Log of Test Pit TR-17-21
 Site 17-Disposal Area
 Volume II - RI, Basewide RI/FS
 Fort Ord, California

A59

DRAWN: DJPc
 JOB NUMBER: 23366 041711

APPROVED: Rfm

DATE: 5/94

REVISED DATE

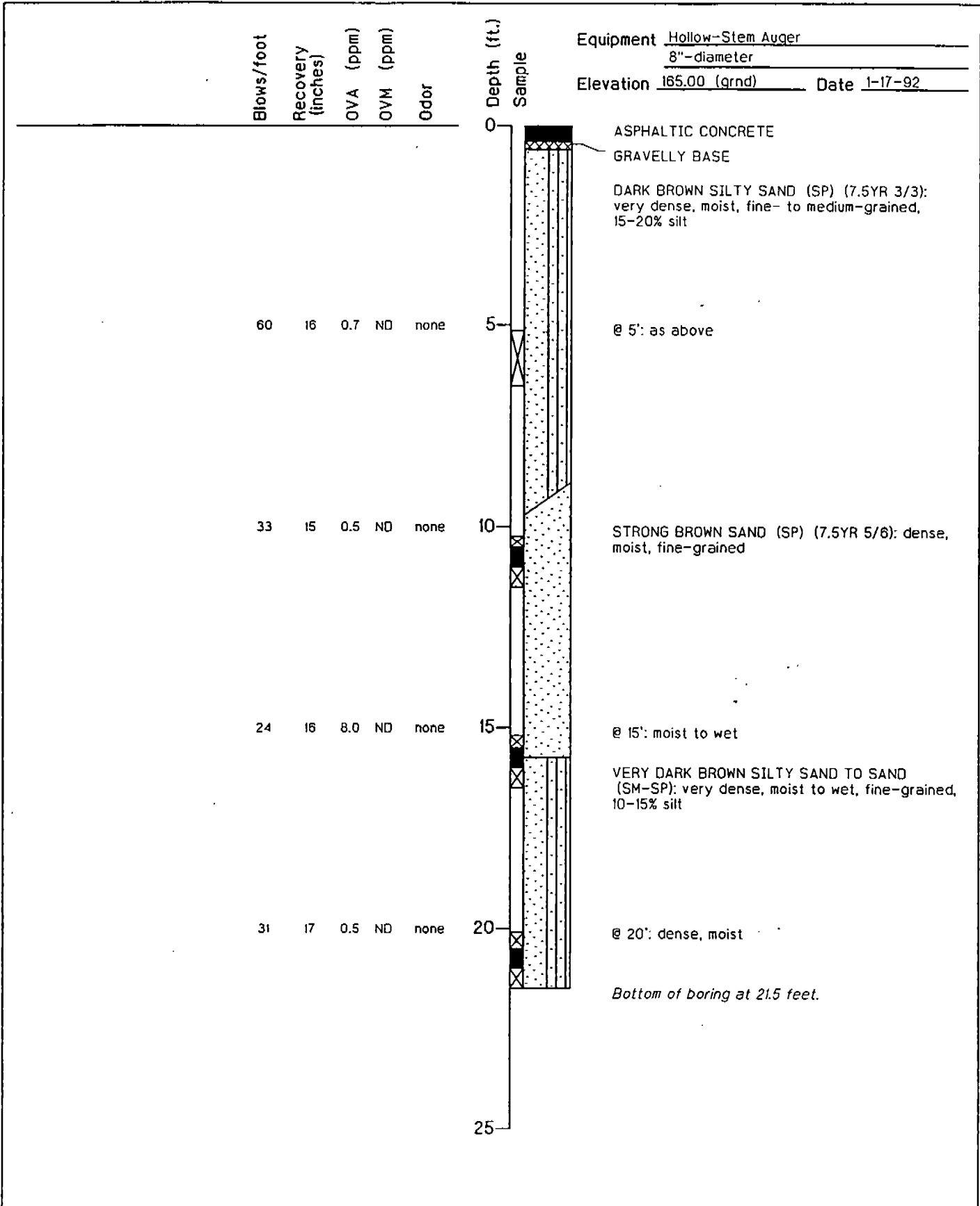

Harding Lawson Associates
Engineering and
Environmental Services

Log of Boring SB-16-01
Site Characterization
Site 16 - DOL Maintenance Yard, Pete's Pond
Fort Ord, California

PLATE

B2

DRAWN GTG	JOB NUMBER 10776 687	APPROVED <i>[Signature]</i>	DATE 12/92	REVISED DATE
--------------	-------------------------	--------------------------------	---------------	--------------

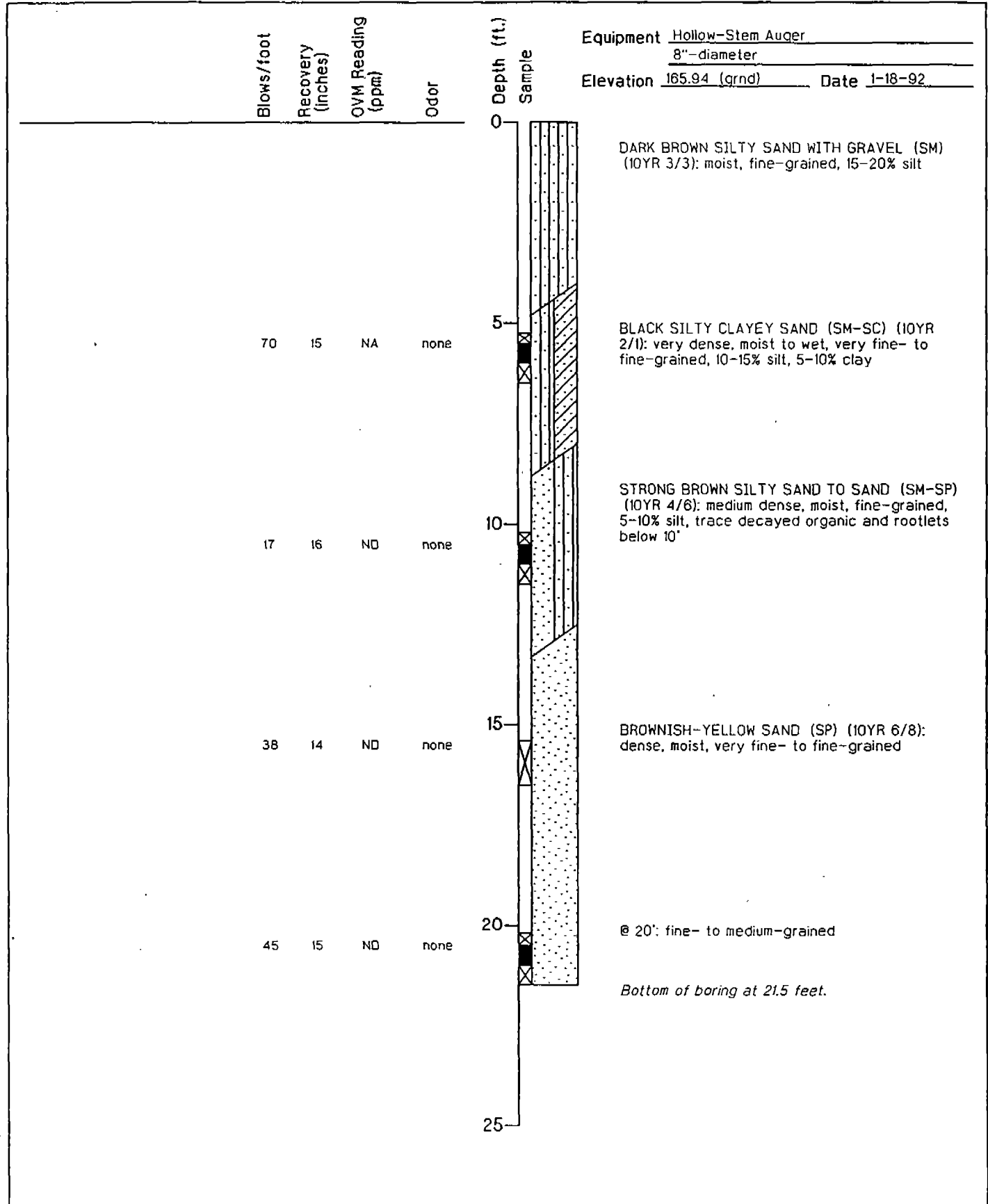

Harding Lawson Associates
 Engineering and Environmental Services

Log of Boring SB-16-02
 Site Characterization
 Site 16 - DOL Maintenance Yard, Pete's Pond
 Fort Ord, California

PLATE

B3

DRAWN GTG	JOB NUMBER 10776 687	APPROVED <i>EM</i>	DATE 12/92	REVISED DATE
--------------	-------------------------	-----------------------	---------------	--------------

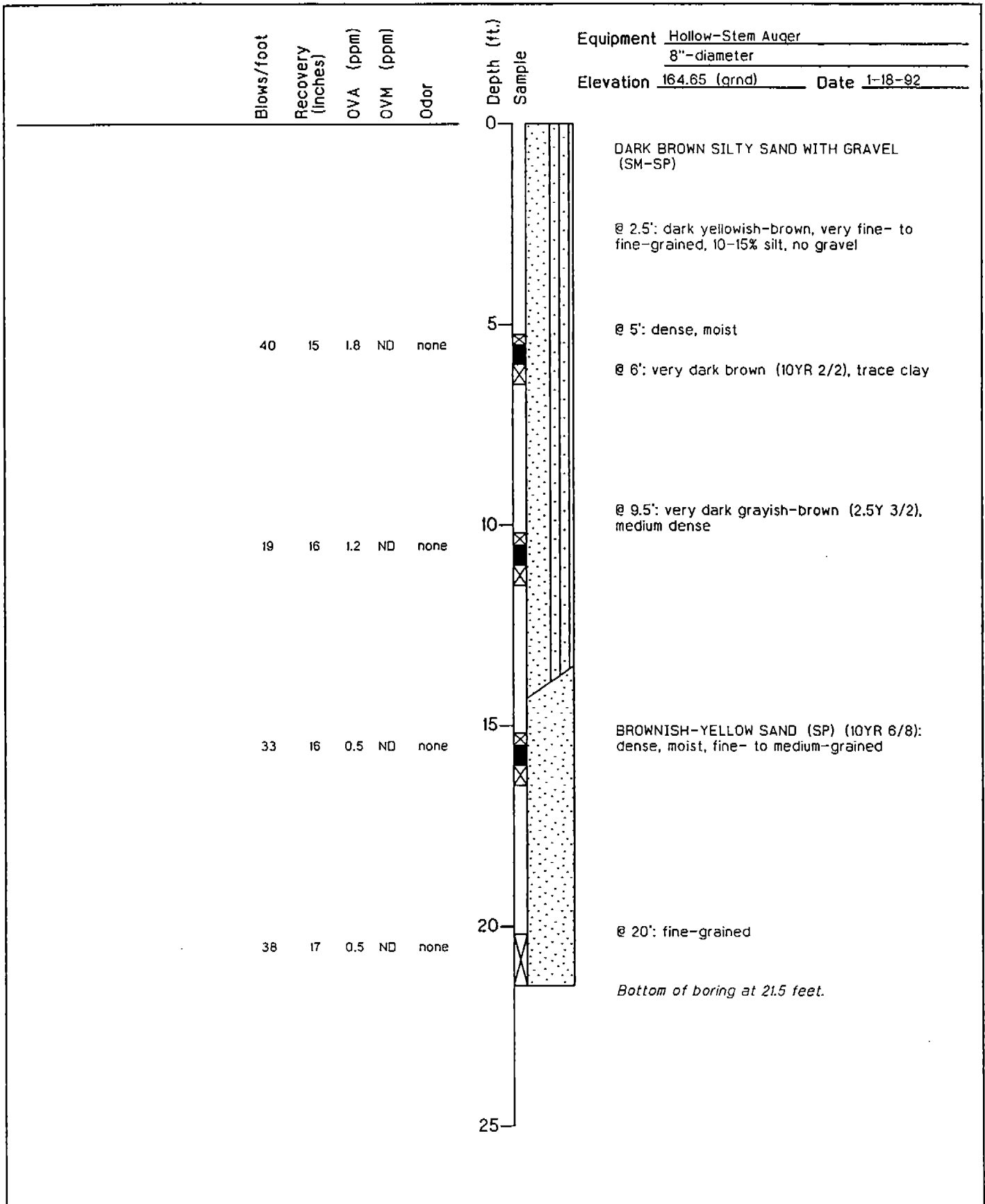

Harding Lawson Associates
Engineering and Environmental Services

Log of Boring SB-18-03
Site Characterization
Site 16 - DOL Maintenance Yard, Pete's Pond
Fort Ord, California

PLATE

B4

DRAWN GTG	JOB NUMBER 10776 687	APPROVED <i>[Signature]</i>	DATE 12/92	REVISED DATE
--------------	-------------------------	--------------------------------	---------------	--------------

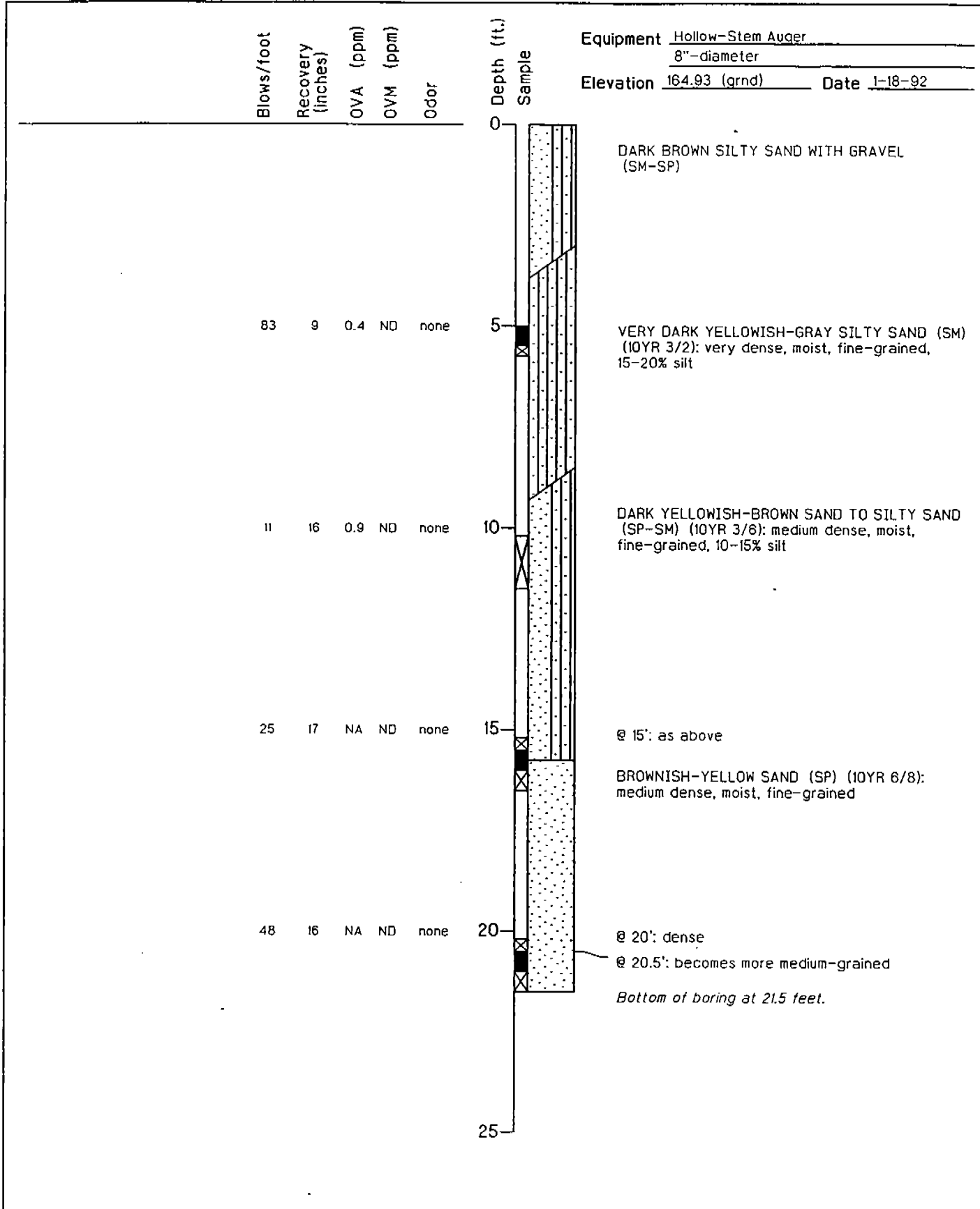

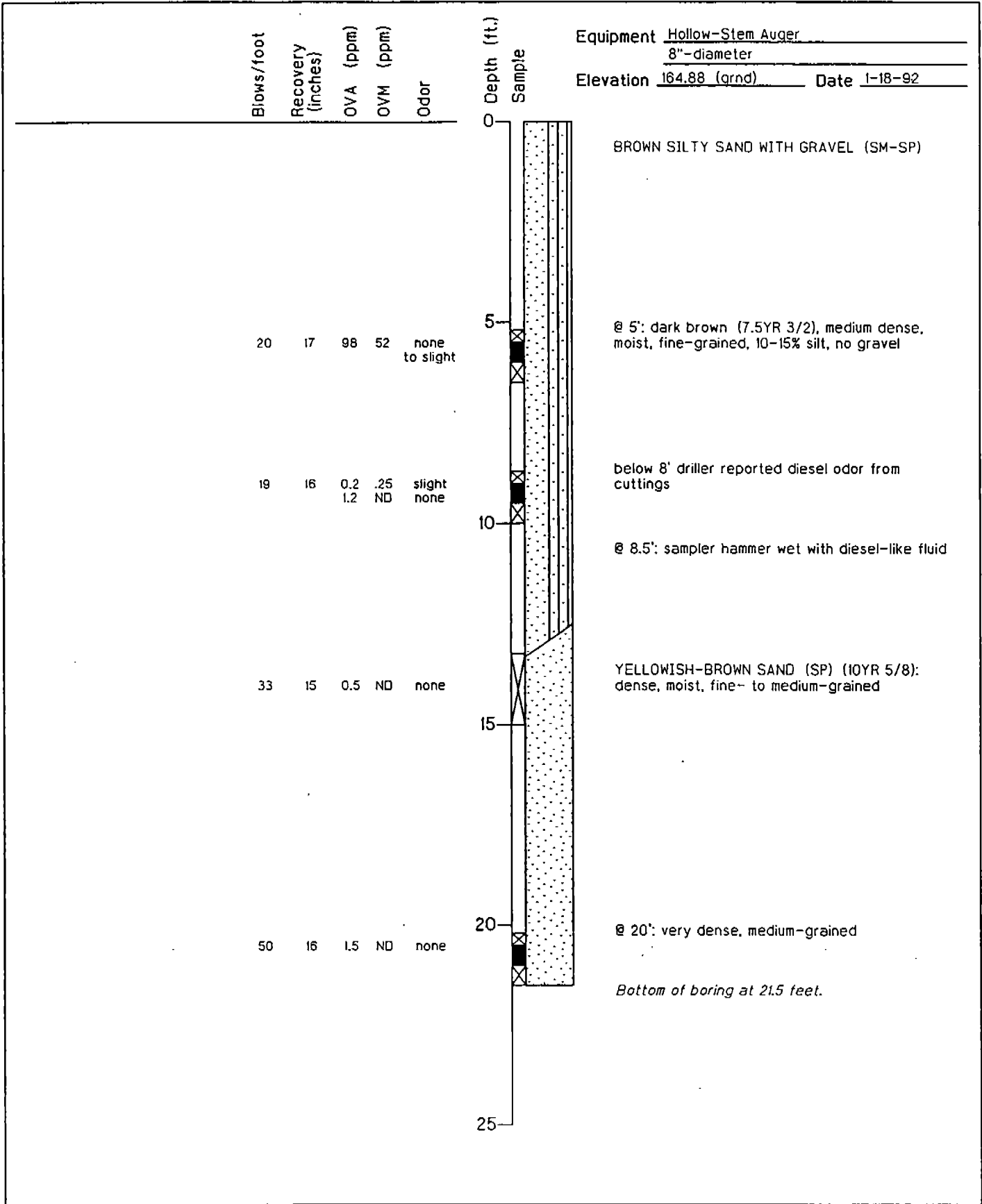

Hardin Lawson Associates
 Engineering and
 Environmental Services

Log of Boring SB-18-05
 Site Characterization
 Site 16 - DOL Maintenance Yard, Pete's Pond
 Fort Ord, California

PLATE

B6

DRAWN GTG	JOB NUMBER 10776 687	APPROVED <i>[Signature]</i>	DATE 12/92	REVISED DATE
--------------	-------------------------	--------------------------------	---------------	--------------

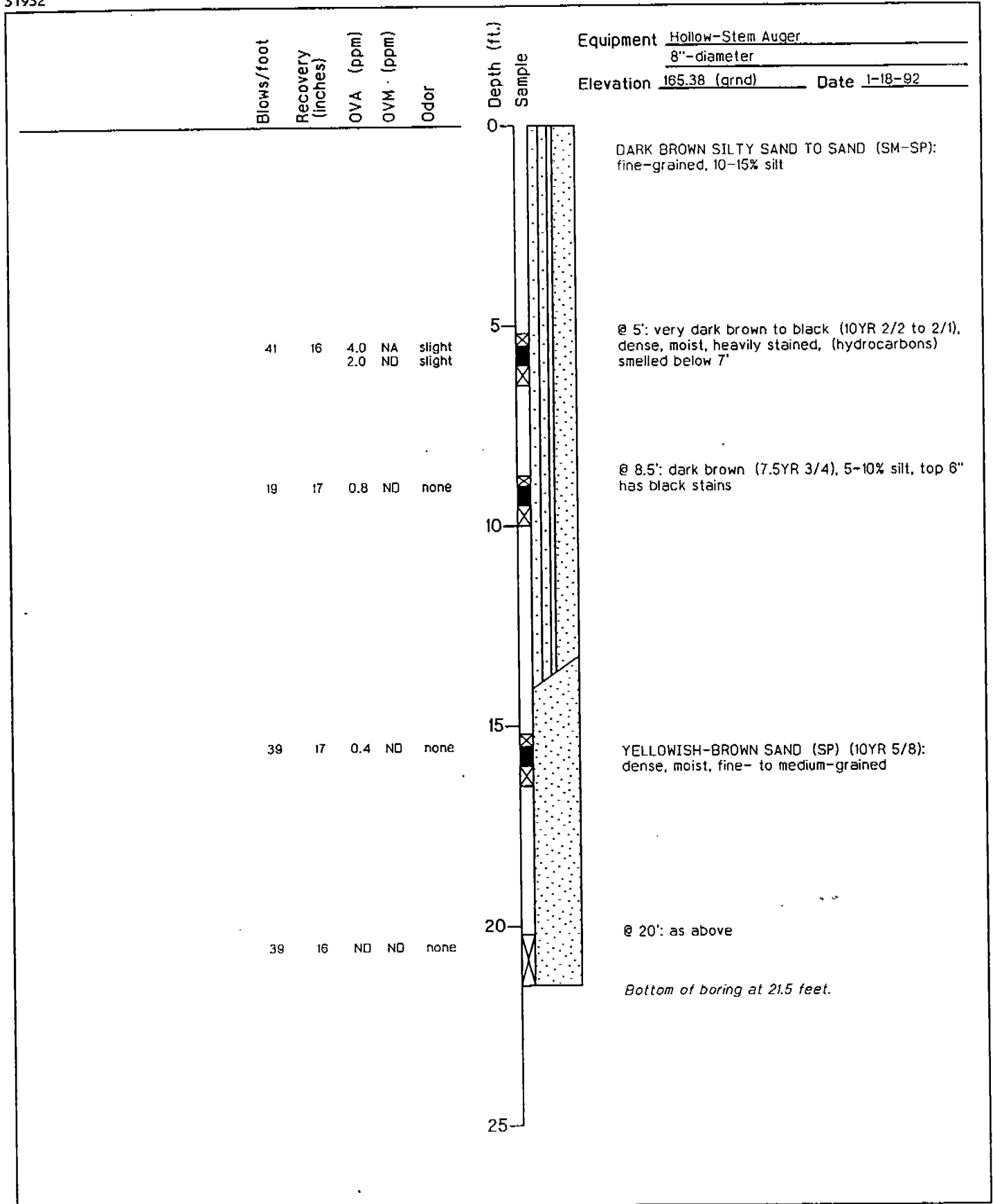

Harding Lawson Associates
Engineering and
Environmental Services

Log of Boring SB-16-07
Site Characterization
Site 16 - DOL Maintenance Yard, Pete's Pond
Fort Ord, California

PLATE

B8

DRAWN GTG	JOB NUMBER 10776 687	APPROVED <i>[Signature]</i>	DATE 12/92	REVISED DATE
--------------	-------------------------	--------------------------------	---------------	--------------

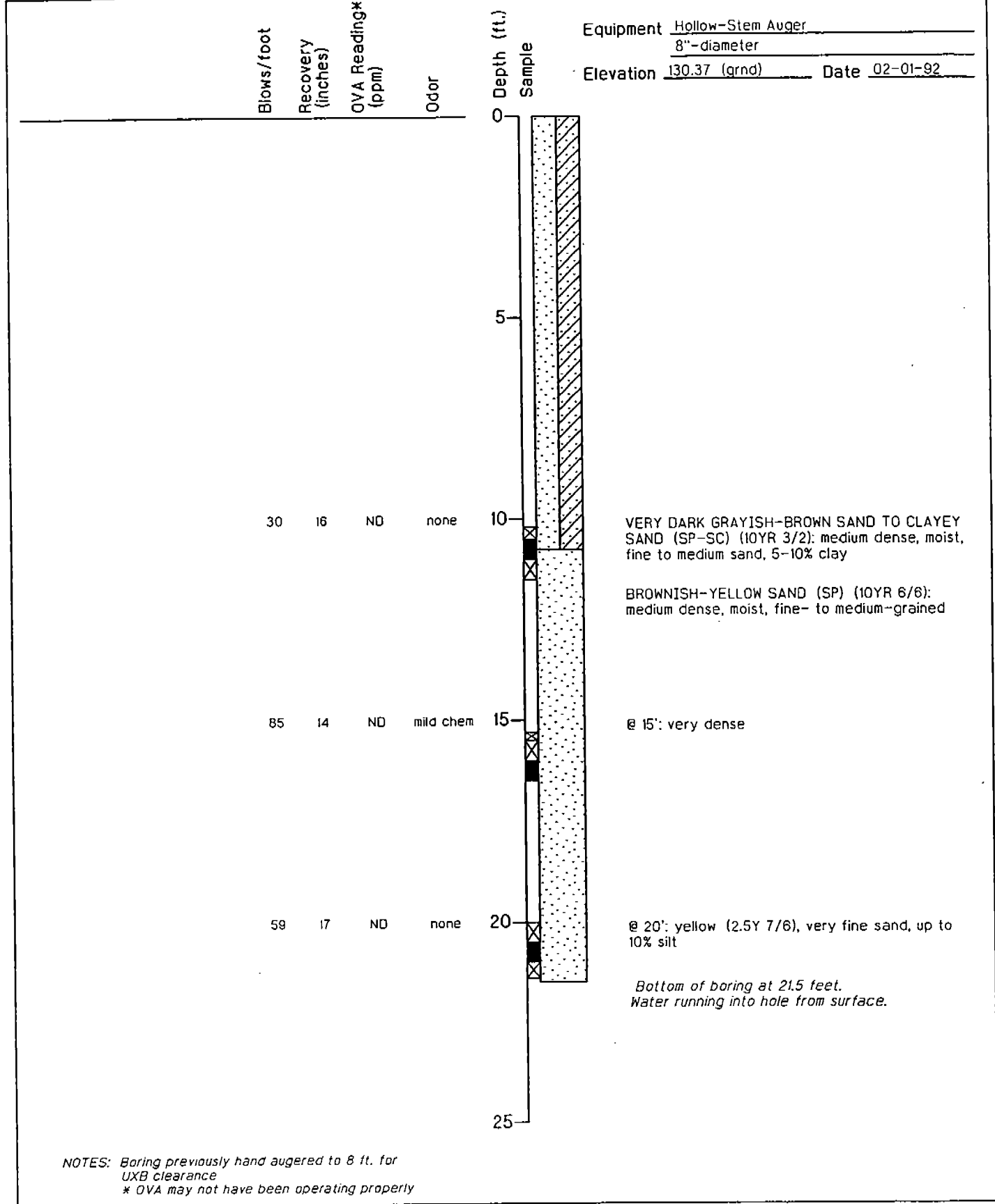

NOTES: Boring previously hand augered to 8 ft. for UXB clearance
* OVA may not have been operating properly

PLATE



Harding Lawson Associates
Engineering and Environmental Services

Log of Boring SB-16-08
Site Characterization
Site 16 - DOL Maintenance Yard, Pete's Pond
Fort Ord, California

B9

DRAWN	JOB NUMBER	APPROVED	DATE	REVISED DATE
LRH	10776 687	<i>EL</i>	12/92	

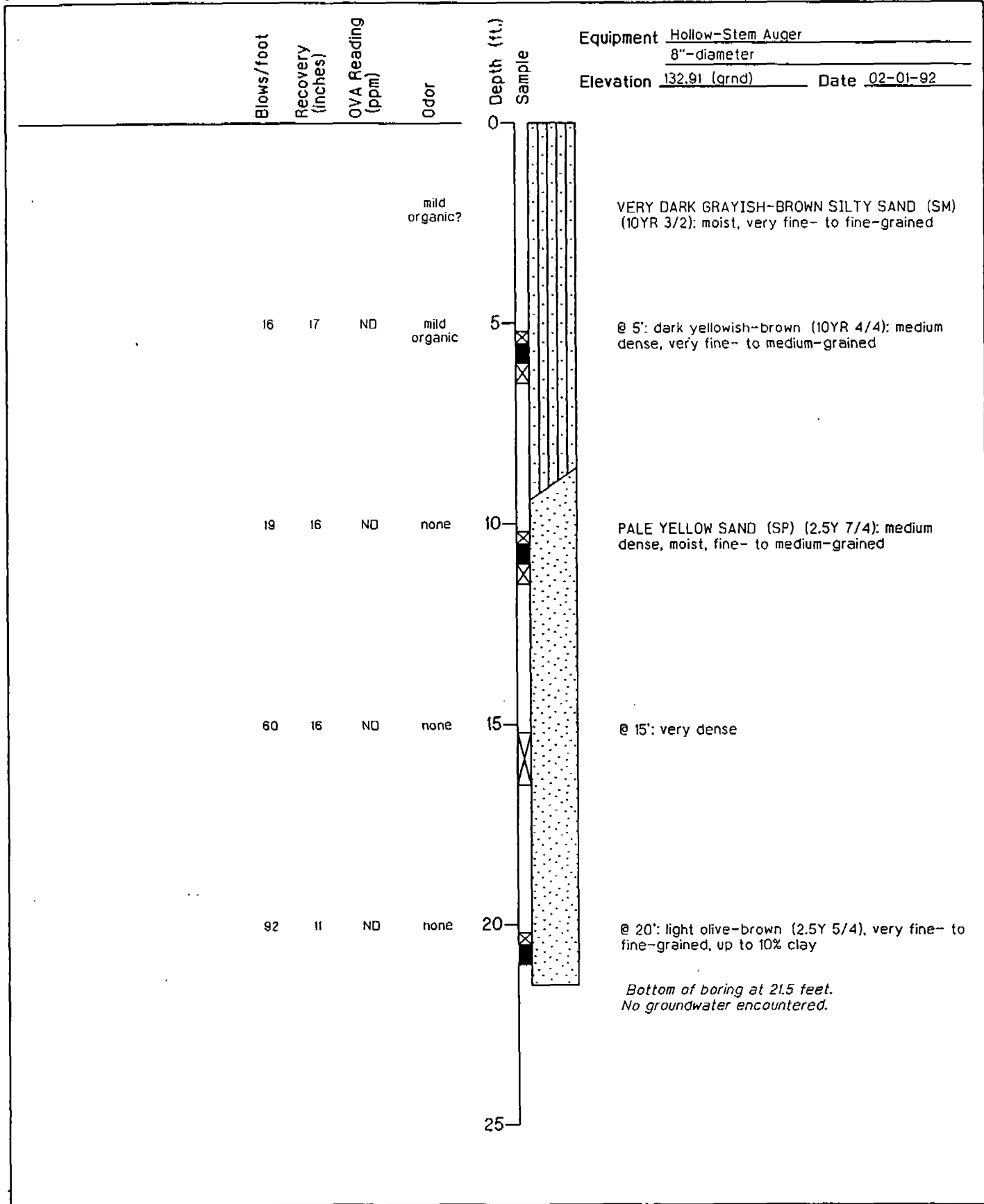

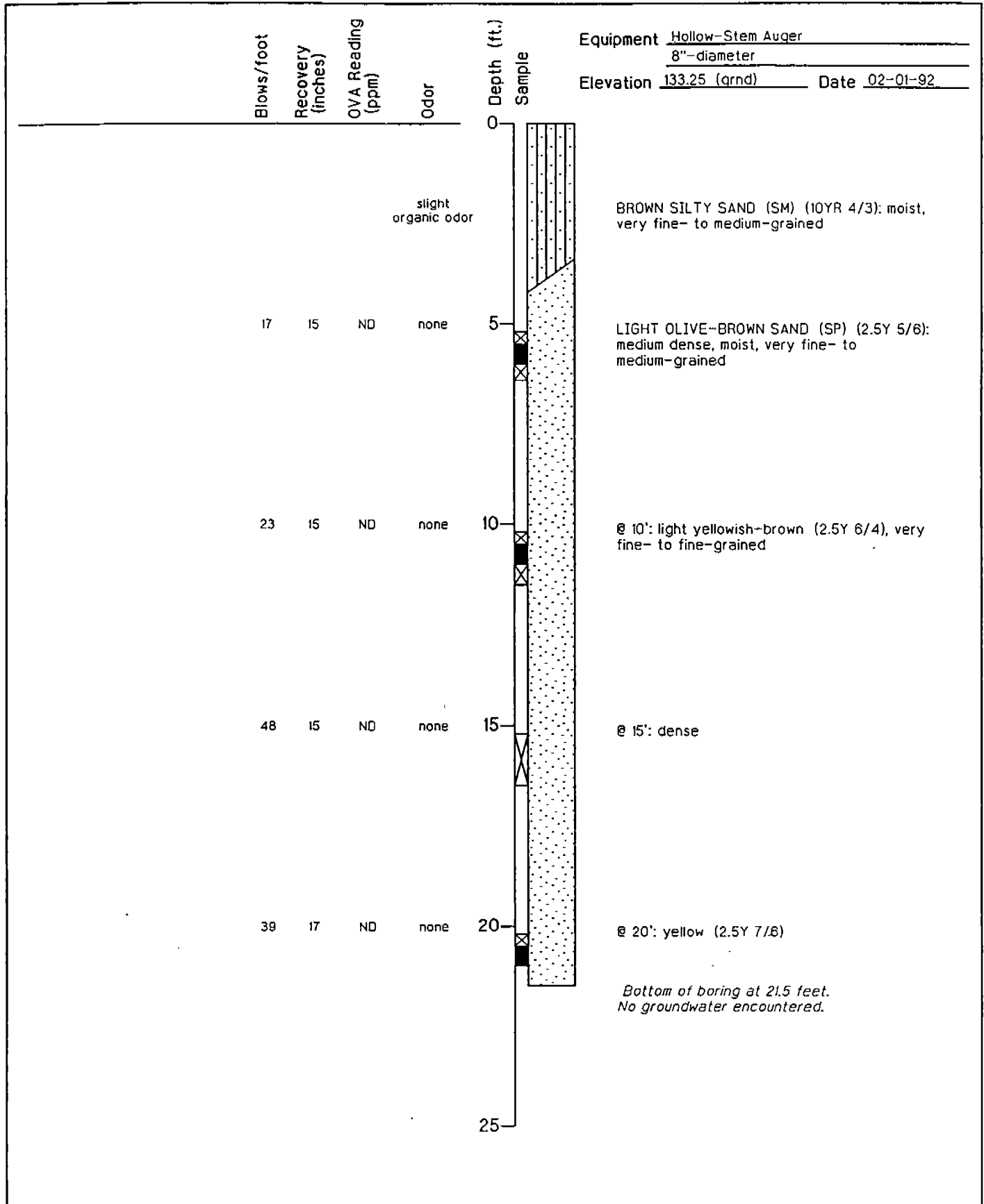

Harding Lawson Associates
 Engineering and
 Environmental Services

Log of Boring SB-16-11
 Site Characterization
 Site 16 - DOL Maintenance Yard, Pete's Pond
 Fort Ord, California

PLATE

B12

DRAWN	JOB NUMBER	APPROVED	DATE	REVISED DATE
LRH	10776 687	<i>EJ</i>	12/92	

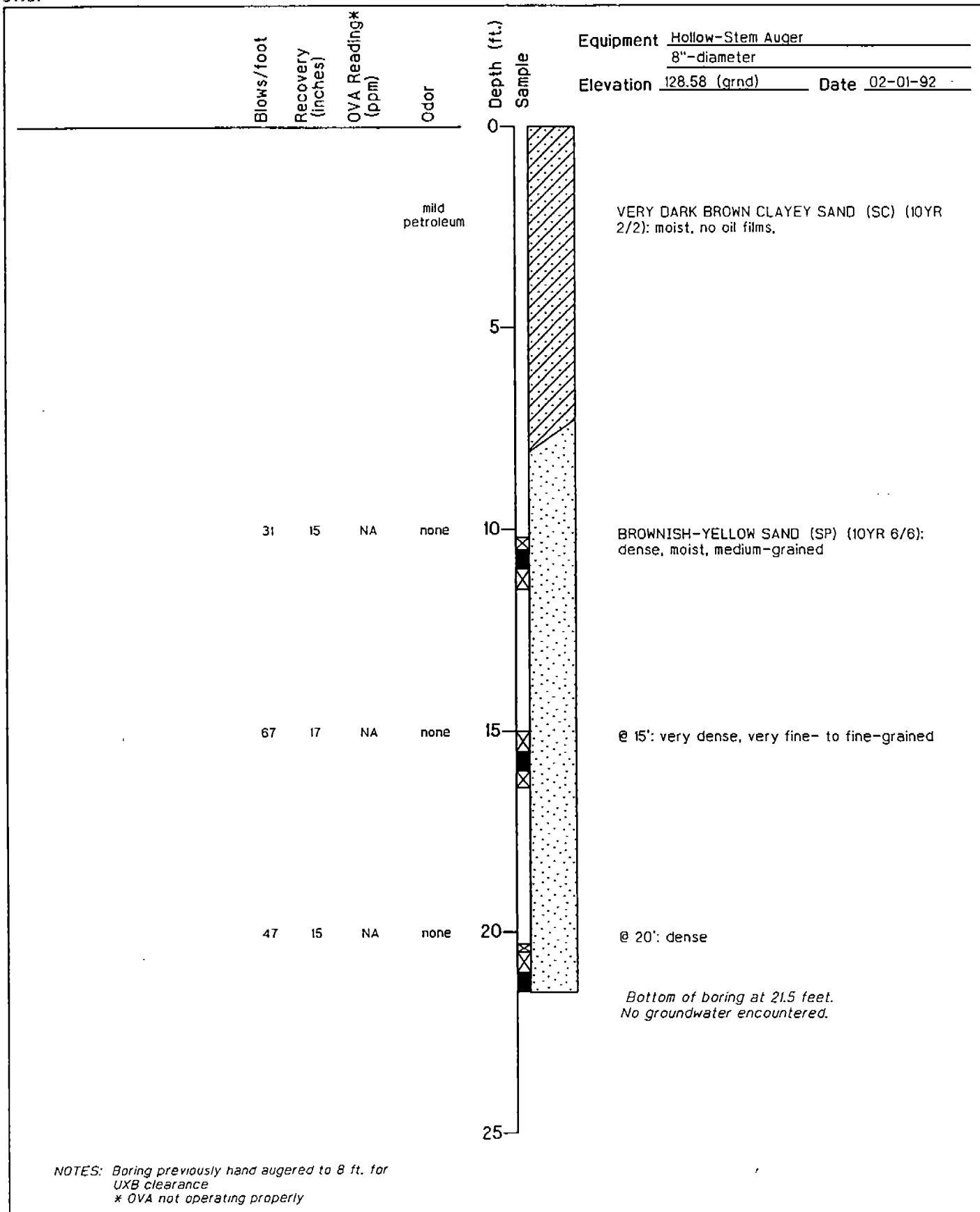

Harding Lawson Associates
Engineering and Environmental Services

Log of Boring SB-18-12
Site Characterization
Site 16 - DOL Maintenance Yard, Pete's Pond
Fort Ord, California

PLATE

B13

DRAWN	JOB NUMBER	APPROVED	DATE	REVISED DATE
LRH	10776 687	<i>[Signature]</i>	12/92	

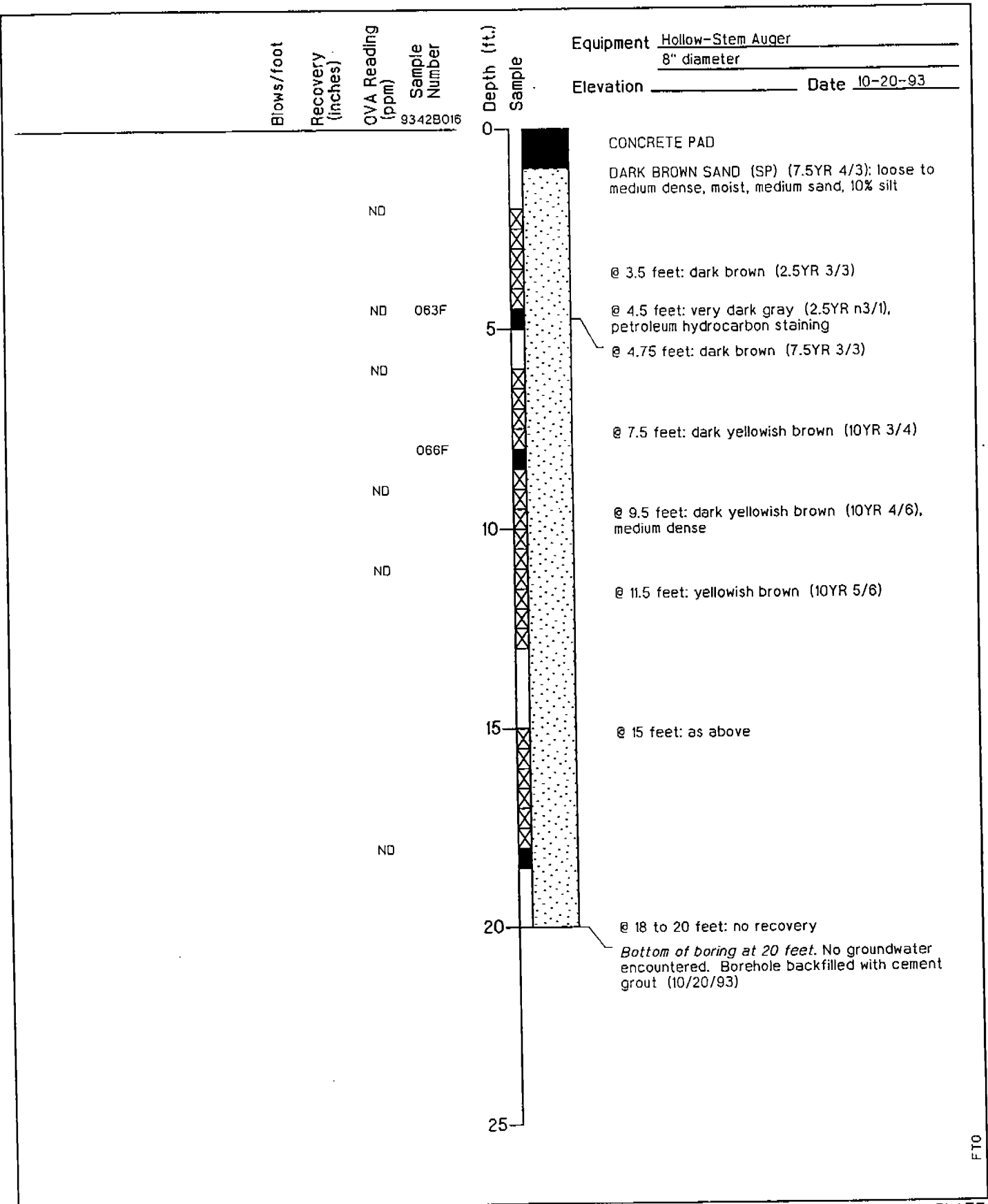

FTO

PLATE



Harding Lawson Associates
Engineering and Environmental Services

Log of Boring SB-16-13
Site 16 - DOL Maintenance Yard
Volume II-RI, Basewide RI/FS
Fort Ord, California

B14

DRAWN	JOB NUMBER	APPROVED	DATE	REVISED DATE
BWH	23366 041711	RFM	1/94	04/29/94

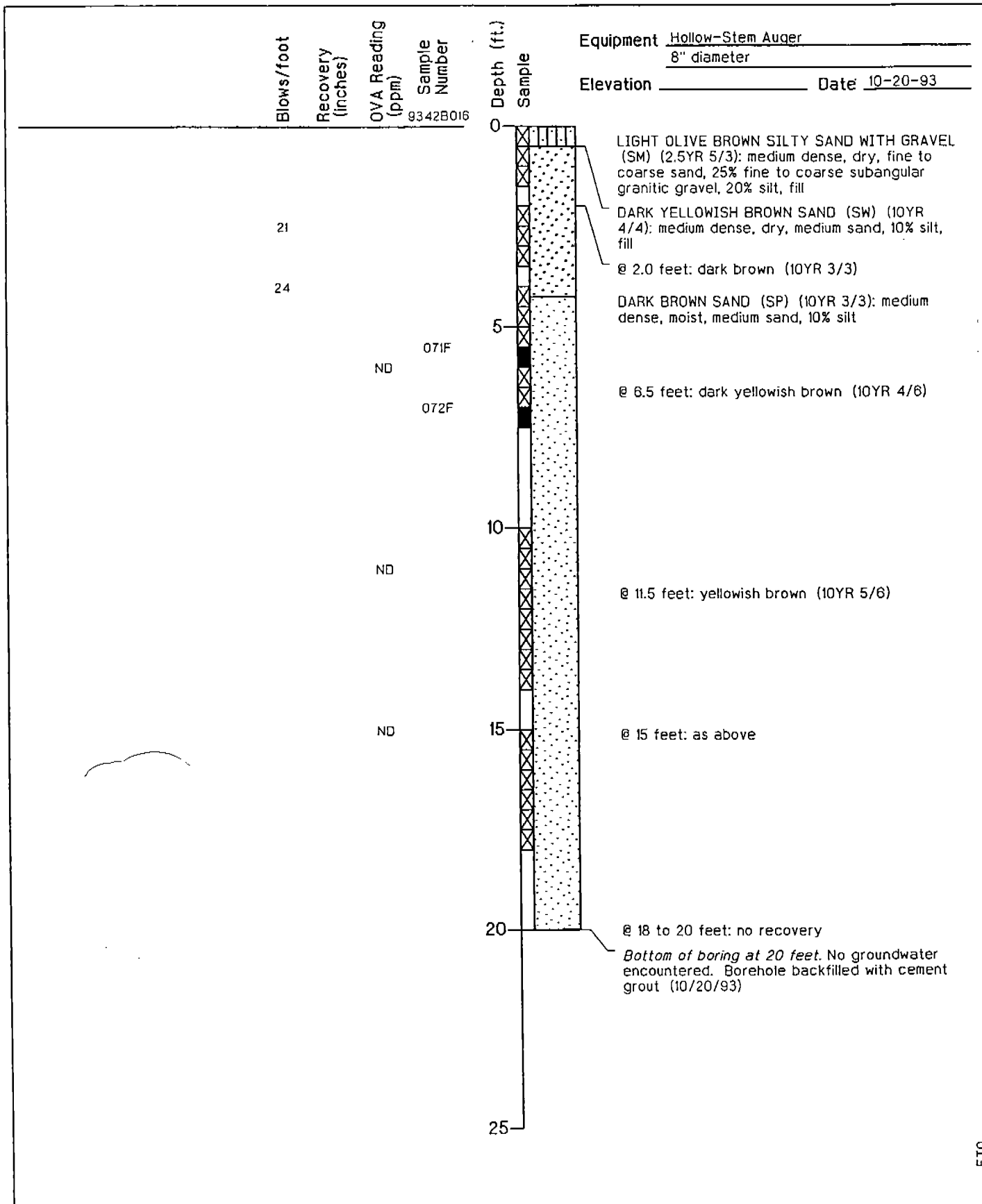

FTO



Harding Lawson Associates
 Engineering and Environmental Services

Log of Boring SB-16-14
 Site 16 - DOL Maintenance Yard
 Volume II-RI, Basewide RI/FS
 Fort Ord, California

PLATE

B 15

DRAWN: BWH
 JOB NUMBER: 23366 041711

APPROVED: *RFM*

DATE: 1/94

REVISED DATE: 04/29/94

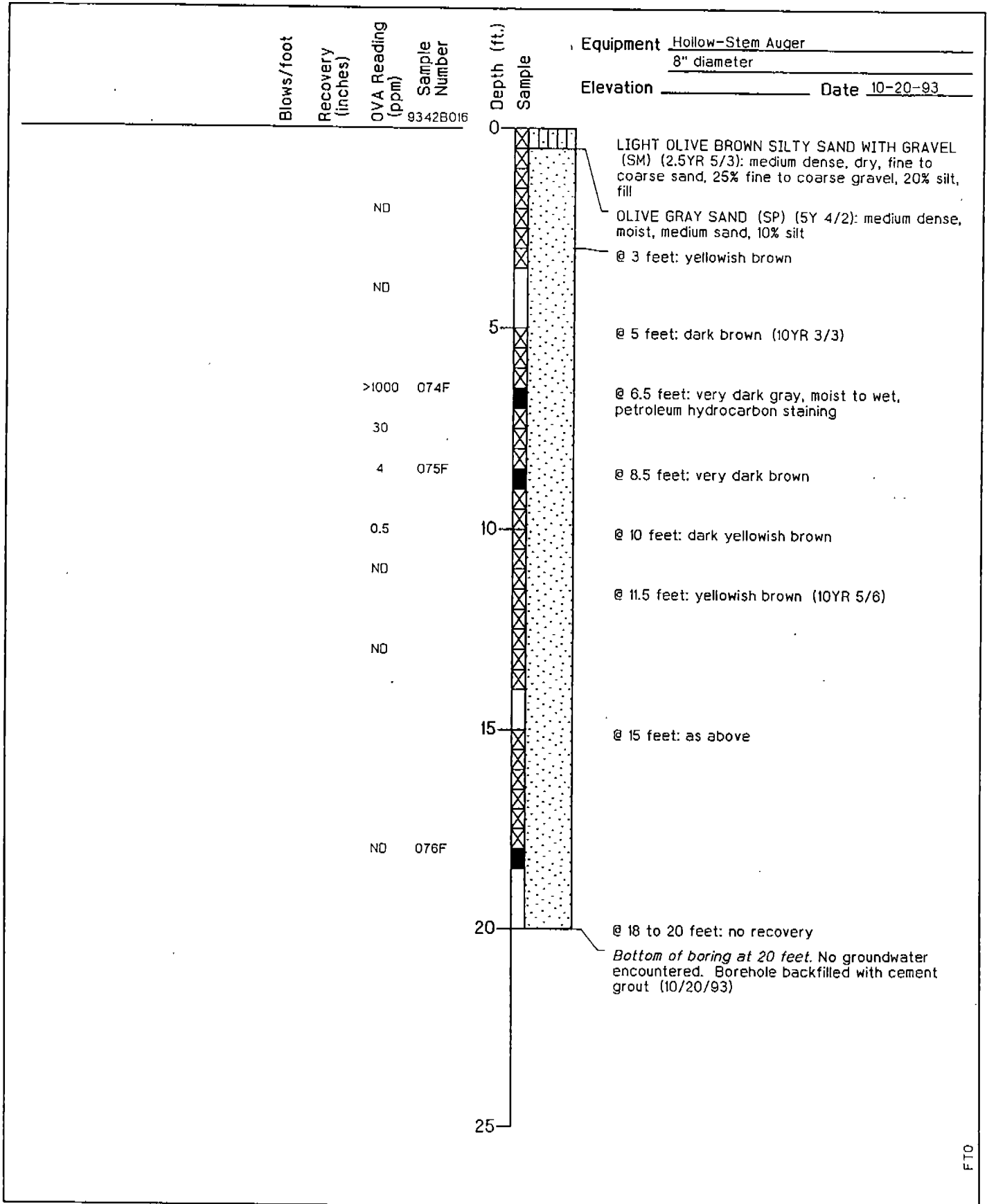

FTO



Harding Lawson Associates
Engineering and
Environmental Services

Log of Boring SB-16-15
Site 16 - DOL Maintenance Yard
Volume II-RI, Basewide RI/FS
Fort Ord, California

PLATE

B16

DRAWN: BWH
JOB NUMBER: 23366 041711

APPROVED: *RFM*

DATE: 1/94

REVISED DATE: 04/29/94

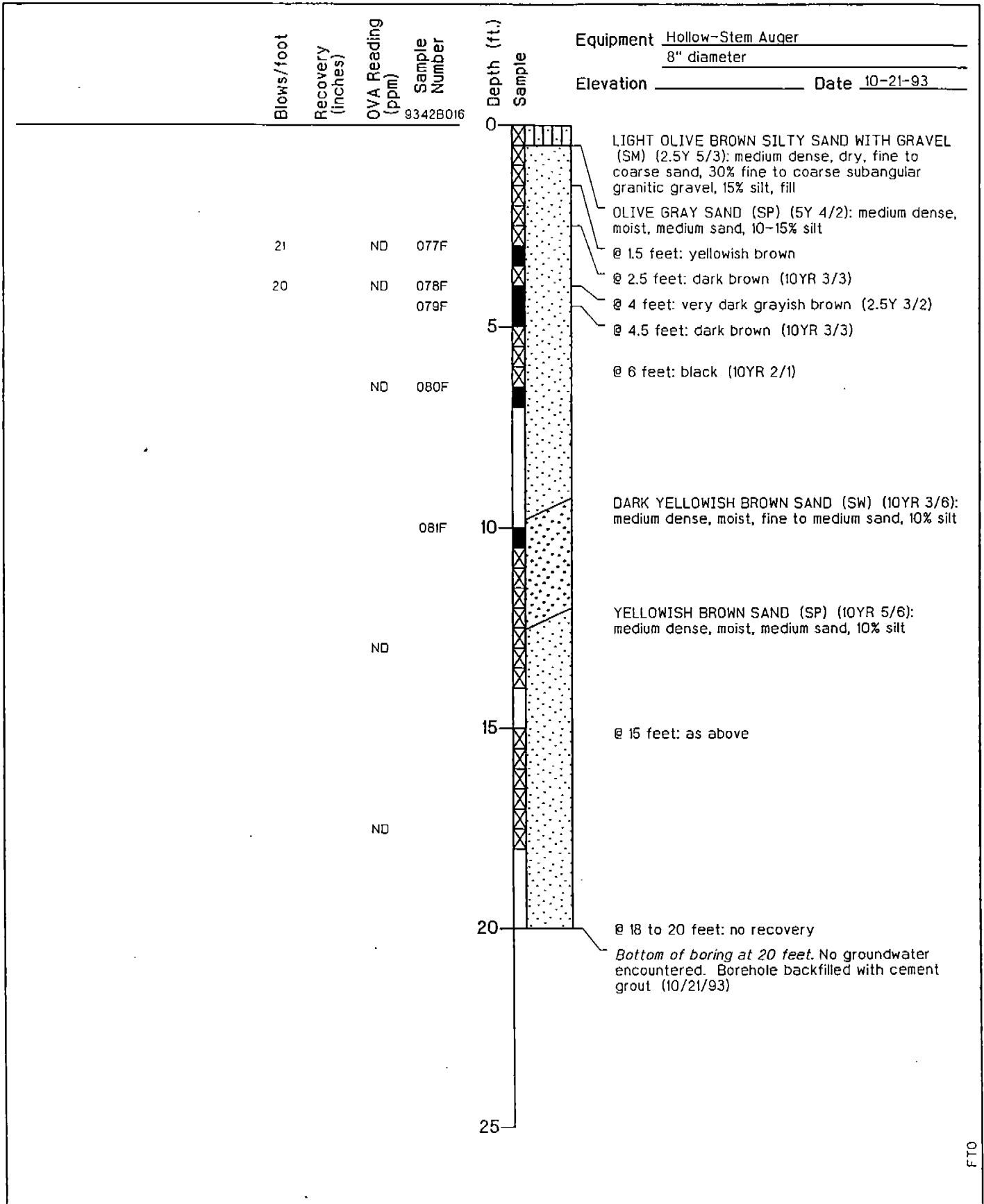

FTO

PLATE



Harding Lawson Associates
Engineering and Environmental Services

Log of Boring SB-18-16
Site 16 - DOL Maintenance Yard
Volume II-RI, Basewide RI/FS
Fort Ord, California

B 17

DRAWN	JOB NUMBER	APPROVED	DATE	REVISED DATE
BWH	23366 041711	<i>RFM</i>	1/94	04/29/94

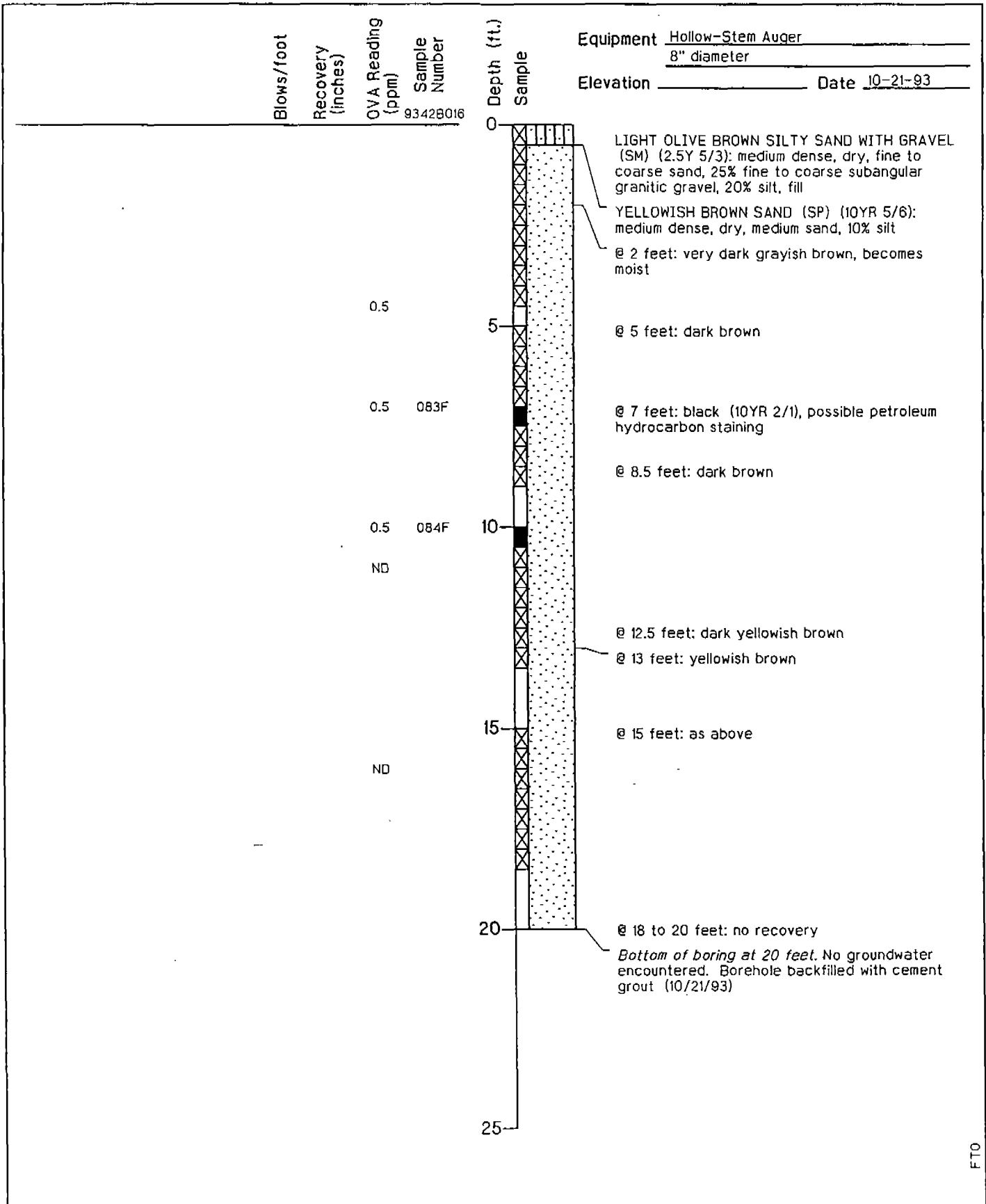

FTO



Harding Lawson Associates
Engineering and
Environmental Services

Log of Boring SB-18-17
Site 16 - DOL Maintenance Yard
Volume II-RI, Basewide RI/FS
Fort Ord, California

PLATE

B18

DRAWN BWH	JOB NUMBER 23366 041711	APPROVED <i>BEM</i>	DATE 1/94	REVISED DATE 04/29/94
--------------	----------------------------	------------------------	--------------	--------------------------

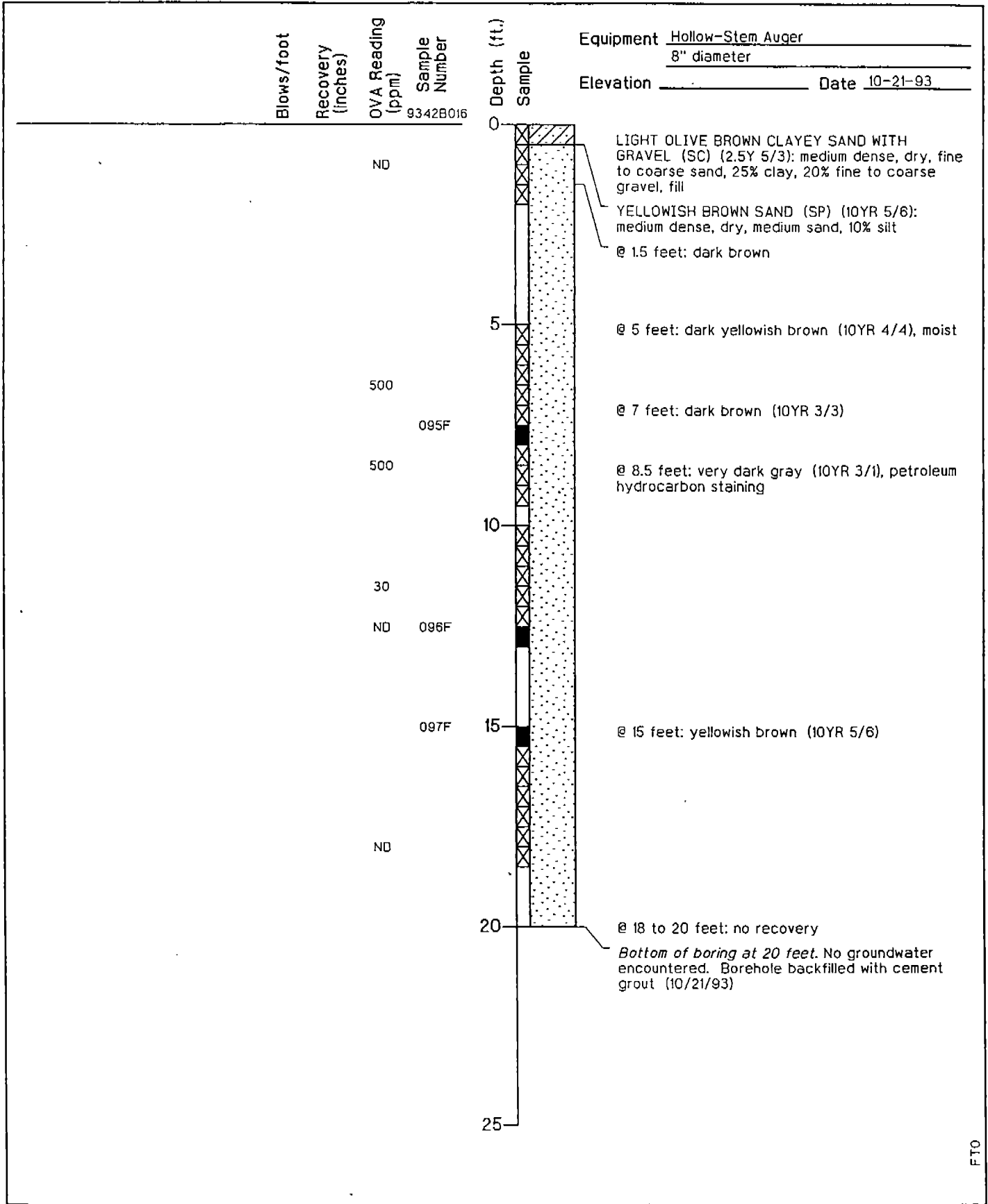

FTO



Harding Lawson Associates
Engineering and Environmental Services

Log of Boring SB-18-19
Site 16 - DOL Maintenance Yard
Volume II-RI, Basewide RI/FS
Fort Ord, California

PLATE

B20

DRAWN BWH	JOB NUMBER 23366 041711	APPROVED <i>RFM</i>	DATE 1/94	REVISED DATE 04/29/94
--------------	----------------------------	------------------------	--------------	--------------------------

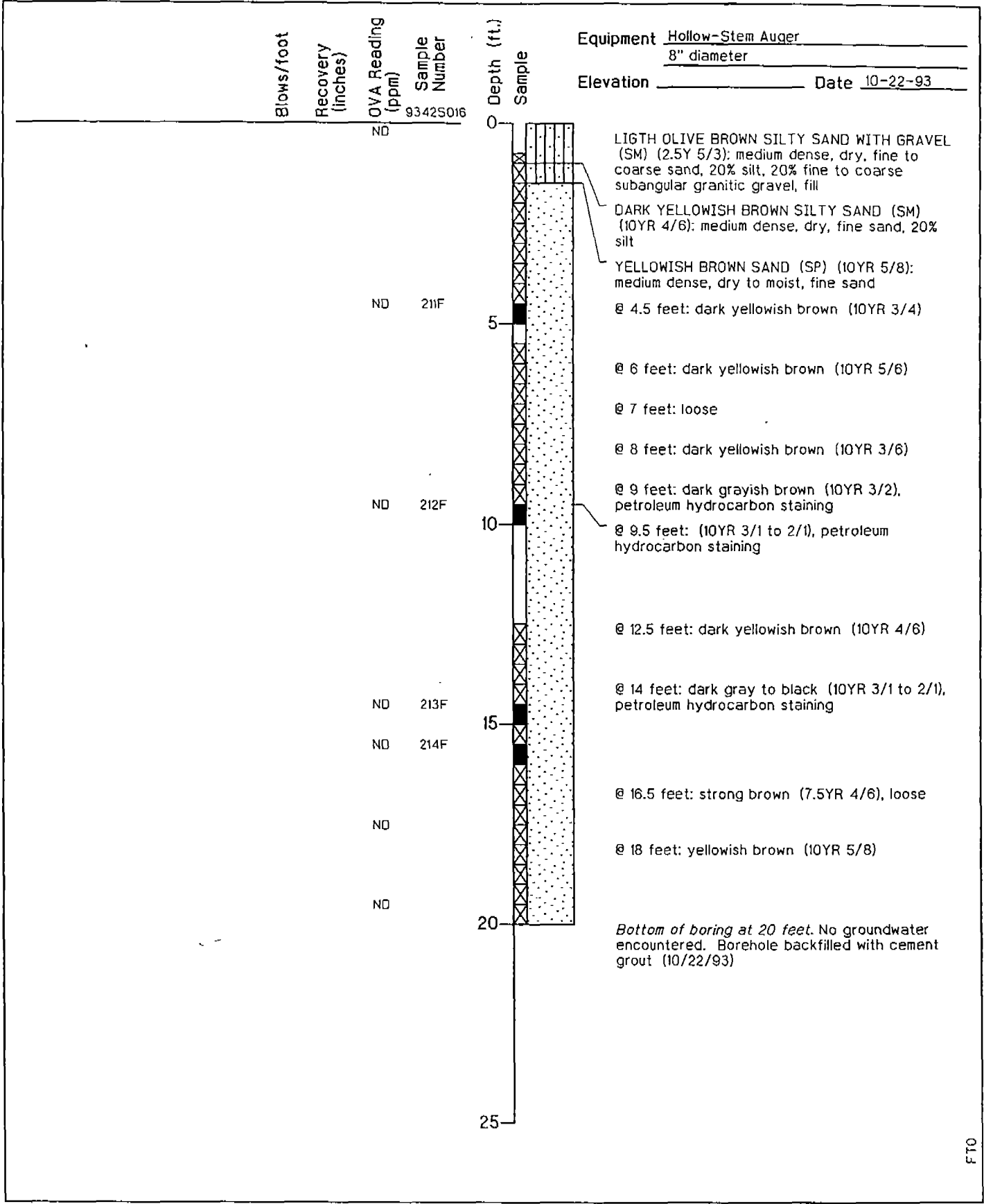

FTO



Harding Lawson Associates
Engineering and Environmental Services

Log of Boring SB-16-20
Site 16 - DOL Maintenance Yard
Volume II-RI, Basewide RI/FS
Fort Ord, California

PLATE

B21

DRAWN	JOB NUMBER	APPROVED	DATE	REVISED DATE
BWH	23366 041711	RFM	1/94	04/29/94

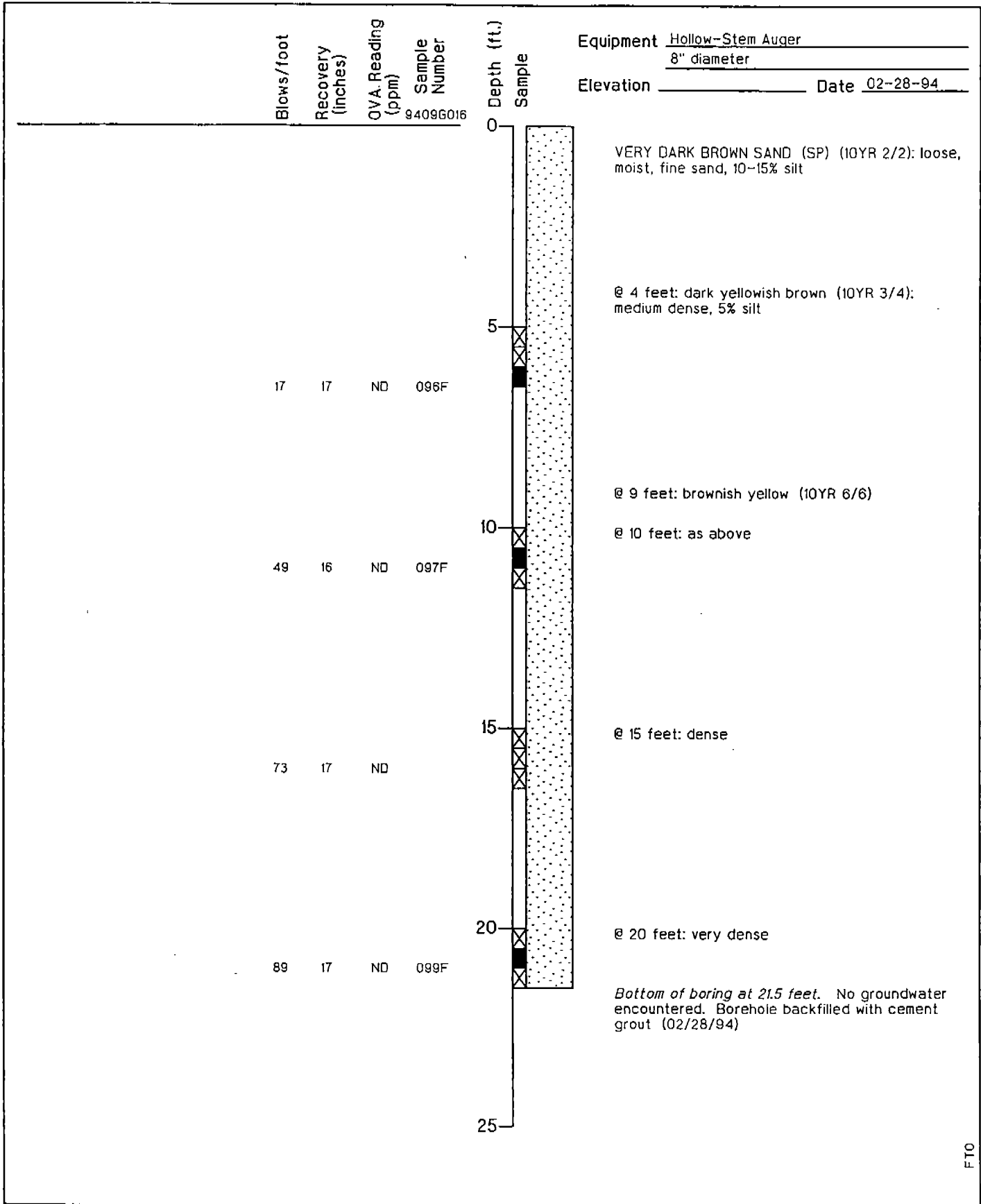

FTO

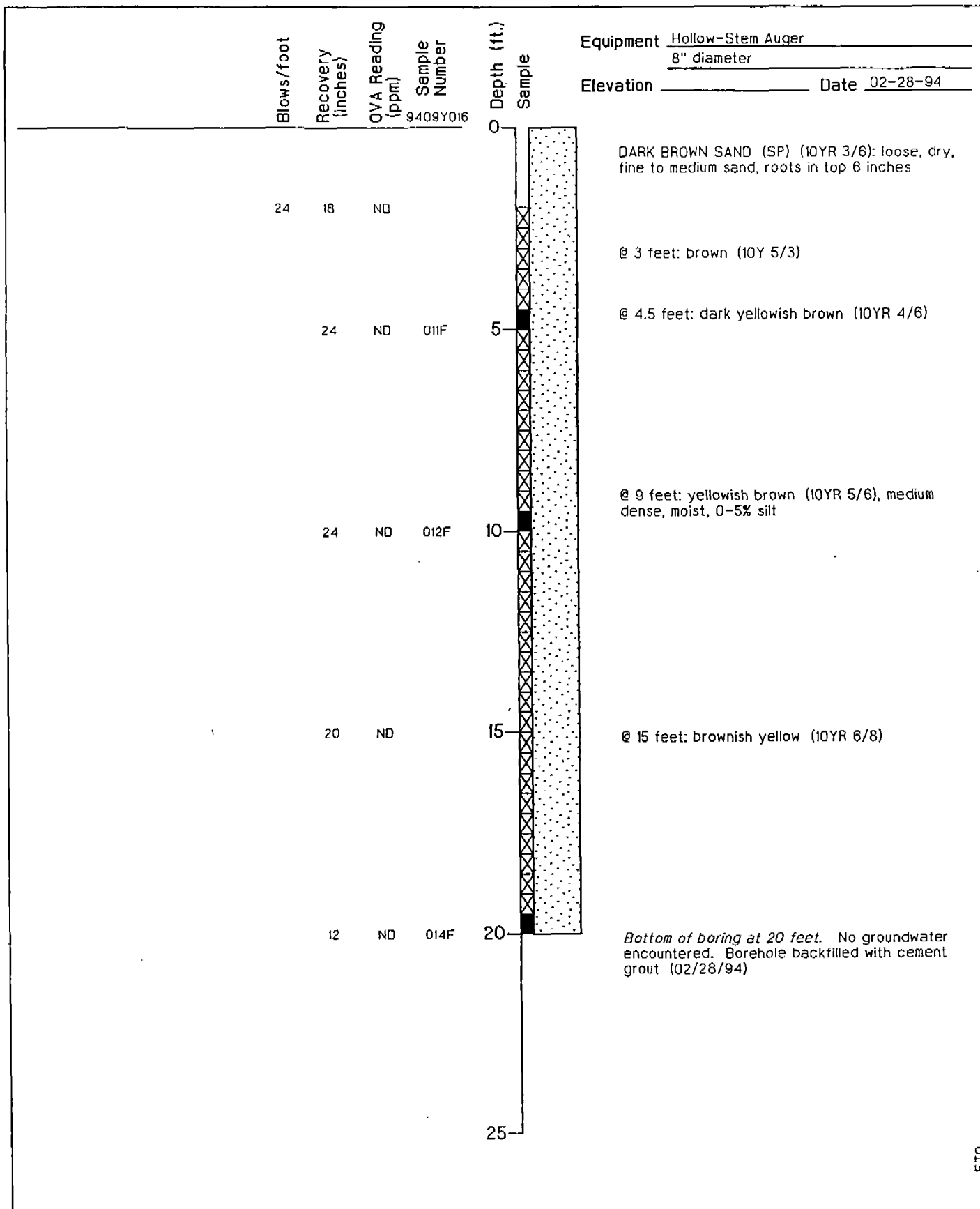

FTO

PLATE



Harding Lawson Associates
 Engineering and Environmental Services

Log of Boring SB-16-22
 Site 16 - Pete's Pond
 Volume II-RI, Basewide RI/FS
 Fort Ord, California

B23

DRAWN	JOB NUMBER	APPROVED	DATE	REVISED DATE
BWH	23366 041711	AFM	03/94	04/29/94

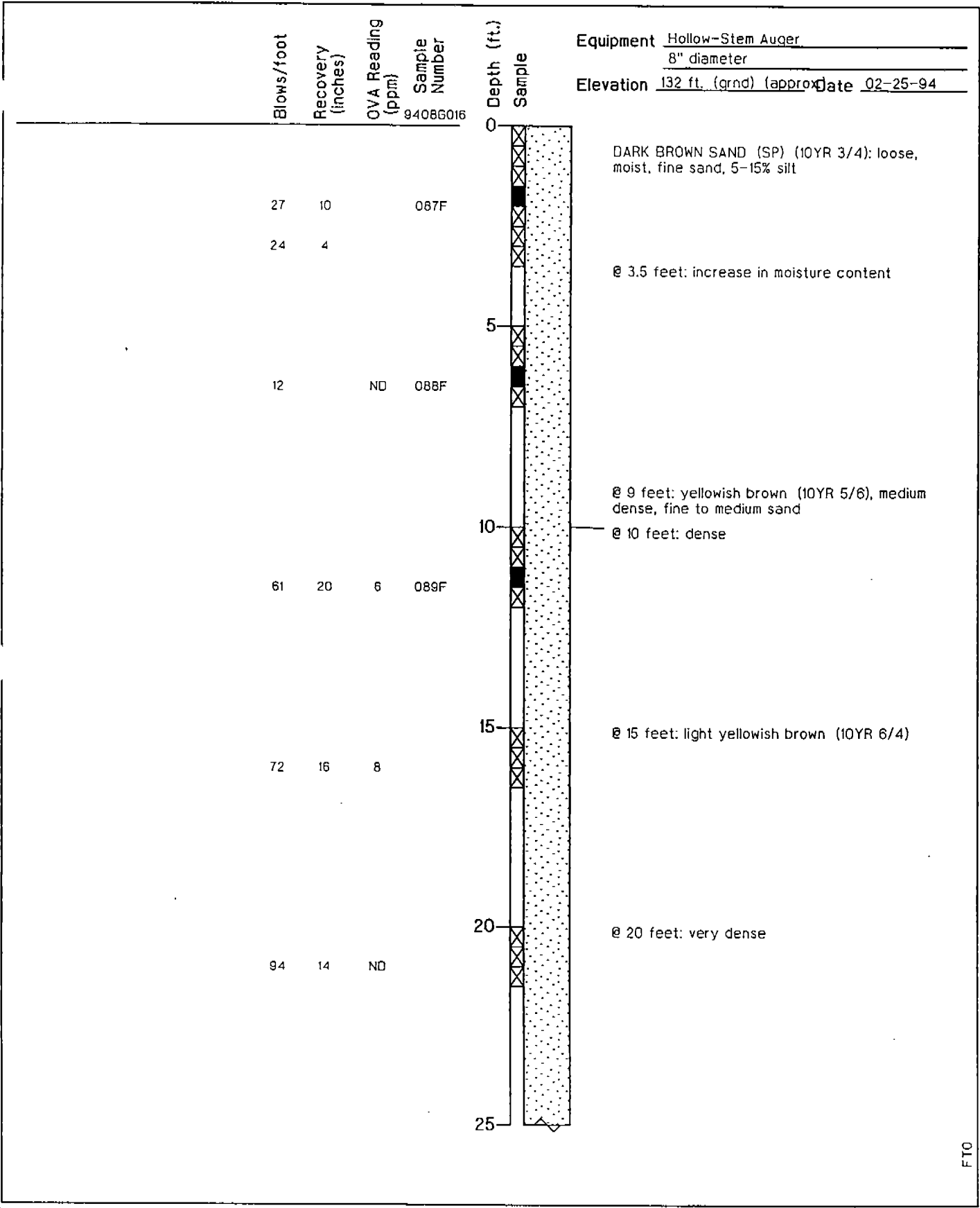

FTO

	Harding Lawson Associates Engineering and Environmental Services	Log of Boring SB-16-23 Site 16 - Pete's Pond Volume II-RI, Basewide RI/FS Fort Ord, California	PLATE B24
	DRAWN: BWH JOB NUMBER: 23366 041711	APPROVED: <i>RFA</i>	DATE: 03/94 REVISED DATE: 04/29/94

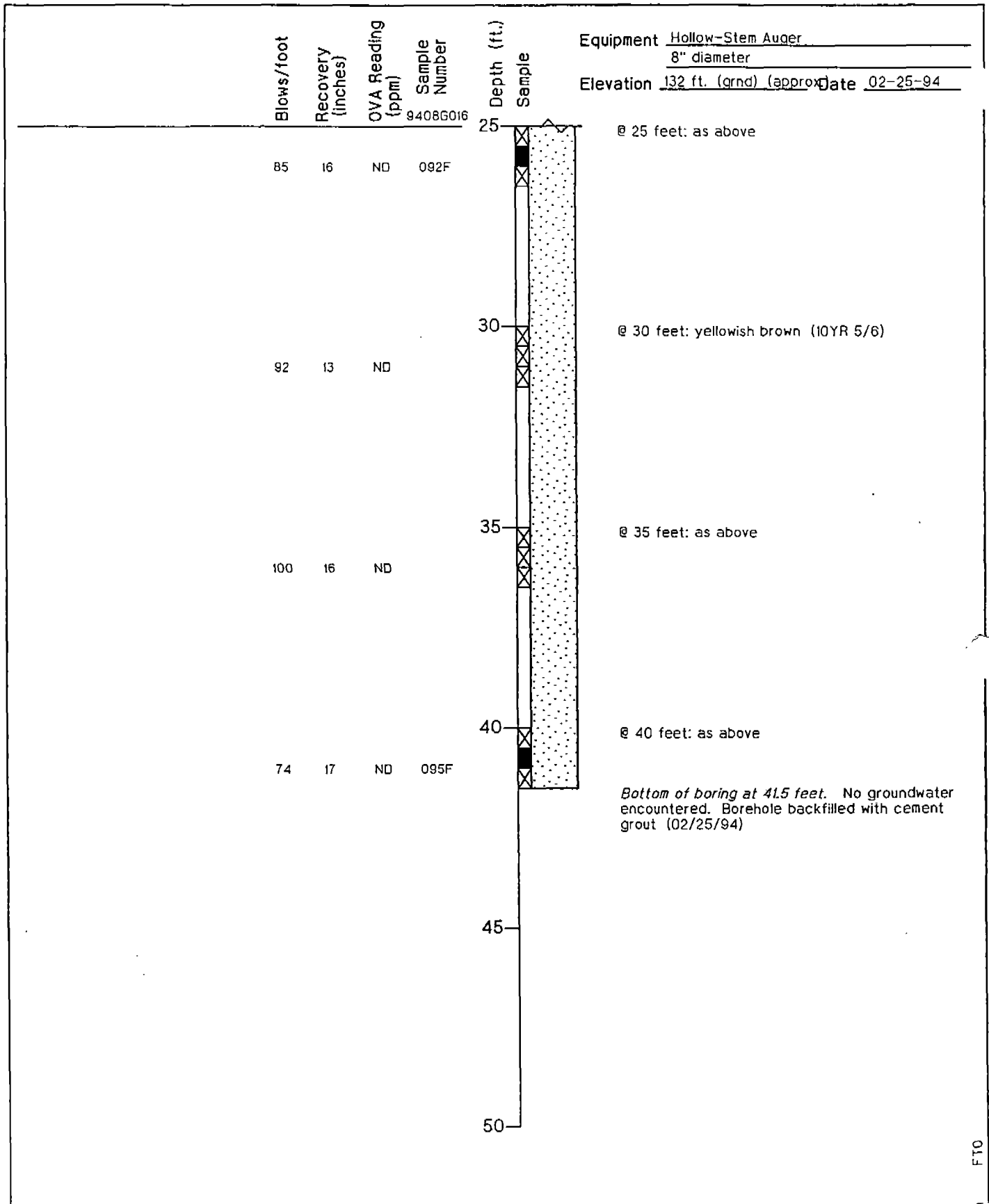

FTO



Harding Lawson Associates
Engineering and
Environmental Services

Log of Boring SB-16-23
Site 16 - Pete's Pond
Volume II-RI, Basewide RI/FS
Fort Ord, California

PLAT

B24

DRAWN: BWH
JOB NUMBER: 23366 041711

APPROVED: *RFM*

DATE: 03/94

REVISED DATE: 04/29/94

Blows/foot
Recovery (inches)
OVA Reading (ppm)
Sample Number
9409G016

Equipment Hollow-Stem Auger
8-1/4" diameter
Elevation ~139 ft. MSL Date 03-01-94

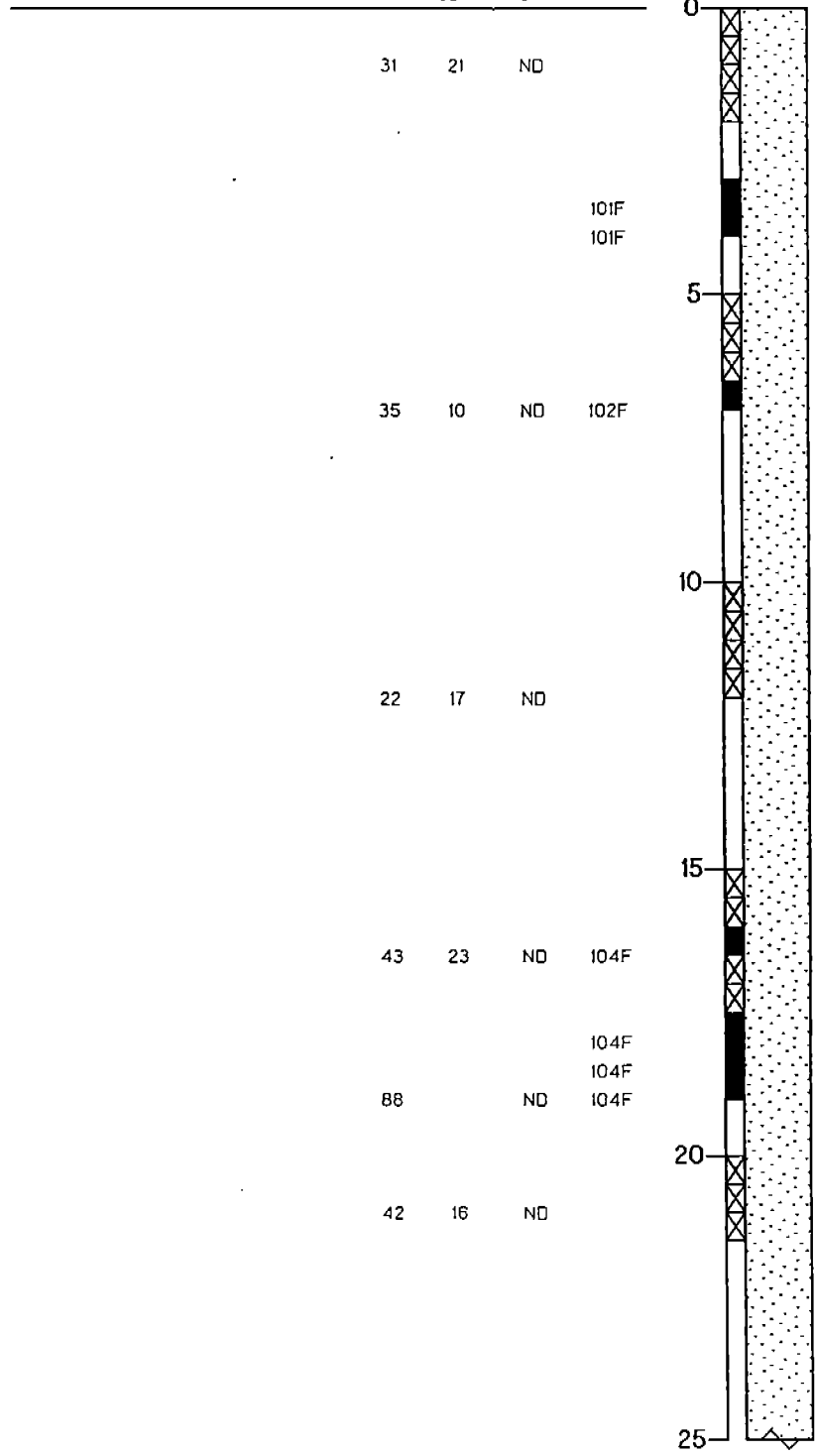

VERY DARK BROWN SAND (SP) (10YR 2/2): loose, moist, fine sand, 10-15% silt, rust stains

@ 8.5 feet: yellowish brown (10YR 5/4): medium dense, fine to medium sand, no silt

@ 11 feet: dry

@ 14 feet: yellowish brown (10YR 6/4), moist

@ 16 feet: brownish yellow (10YR 6/6), fine sand

@ 20 feet: as above

FTO



Harding Lawson Associates
Engineering and
Environmental Services

Log of Boring SB-16-24
Site 16 - Pete's Pond Extension
Volume II-RI, Basewide RI/FS
Fort Ord, California

PLATE

B25

DRAWN	JOB NUMBER	APPROVED	DATE	REVISED DATE
LRH	23366 041711	<i>RFM</i>	03/94	04/29/94

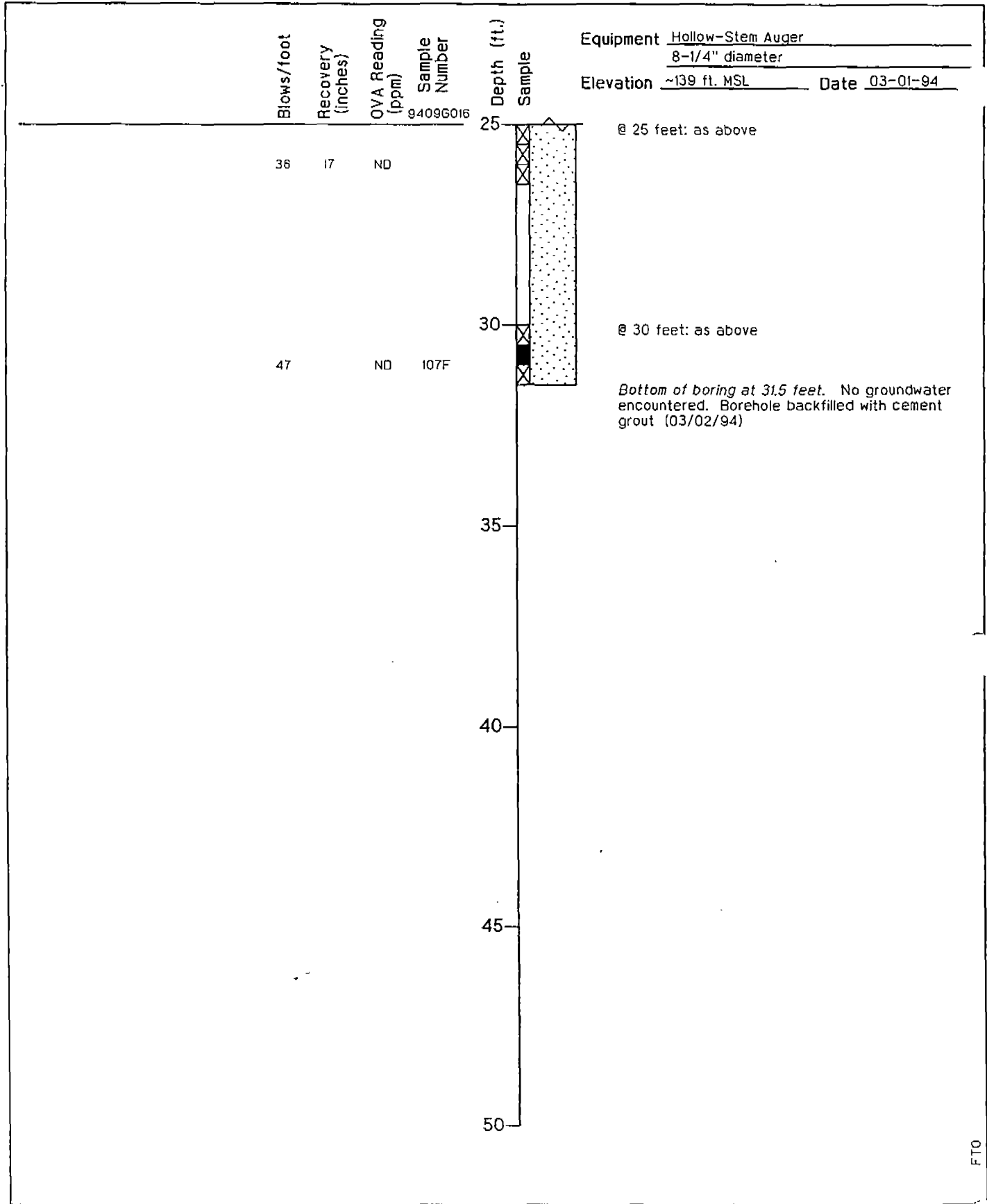

FTO



Harding Lawson Associates
Engineering and
Environmental Services

Log of Boring SB-16-24
Site 16 - Pete's Pond Extension
Volume II-RI, Basewide RI/FS
Fort Ord, California

PLA

B25

DRAWN: LRH
JOB NUMBER: 23366 041711

APPROVED: RFM

DATE: 03/94

REVISED DATE: 04/29/94

Blows/foot
Recovery (inches)
OVA Reading (ppm)
Sample Number

Depth (ft.)
Sample

Equipment Hollow-Stem Auger
8-1/4" diameter
Elevation _____ Date 03-15-94

9411Y016

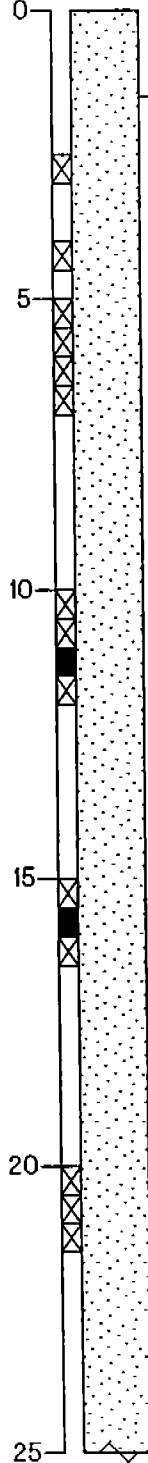

DARK BROWN SAND (SP) (10YR 3/3): loose, moist, fine to medium sand
Hand augered for first 5 feet

@ 4 feet: yellowish brown (10YR 5/6), fine sand

@ 6 feet: brownish yellow (10YR 6/6), medium dense

@ 11 feet: dense

@ 15 feet: fine to medium sand

@ 20 feet: very dense

Blows/foot	Recovery (inches)	OVA Reading (ppm)	Sample Number
40	20	ND	
56	20	ND	085F
54	16	ND	086F
88	18	ND	

F10



Harding Lawson Associates
Engineering and Environmental Services

Log of Boring SB-18-25
Site 16 - Pete's Pond Extension
Volume II-RI, Basewide RI/FS
Fort Ord, California

PLATE

B26

DRAWN	JOB NUMBER	APPROVED	DATE	REVISED DATE
LRH	23366 041711	<i>RFM</i>	04/94	04/29/94

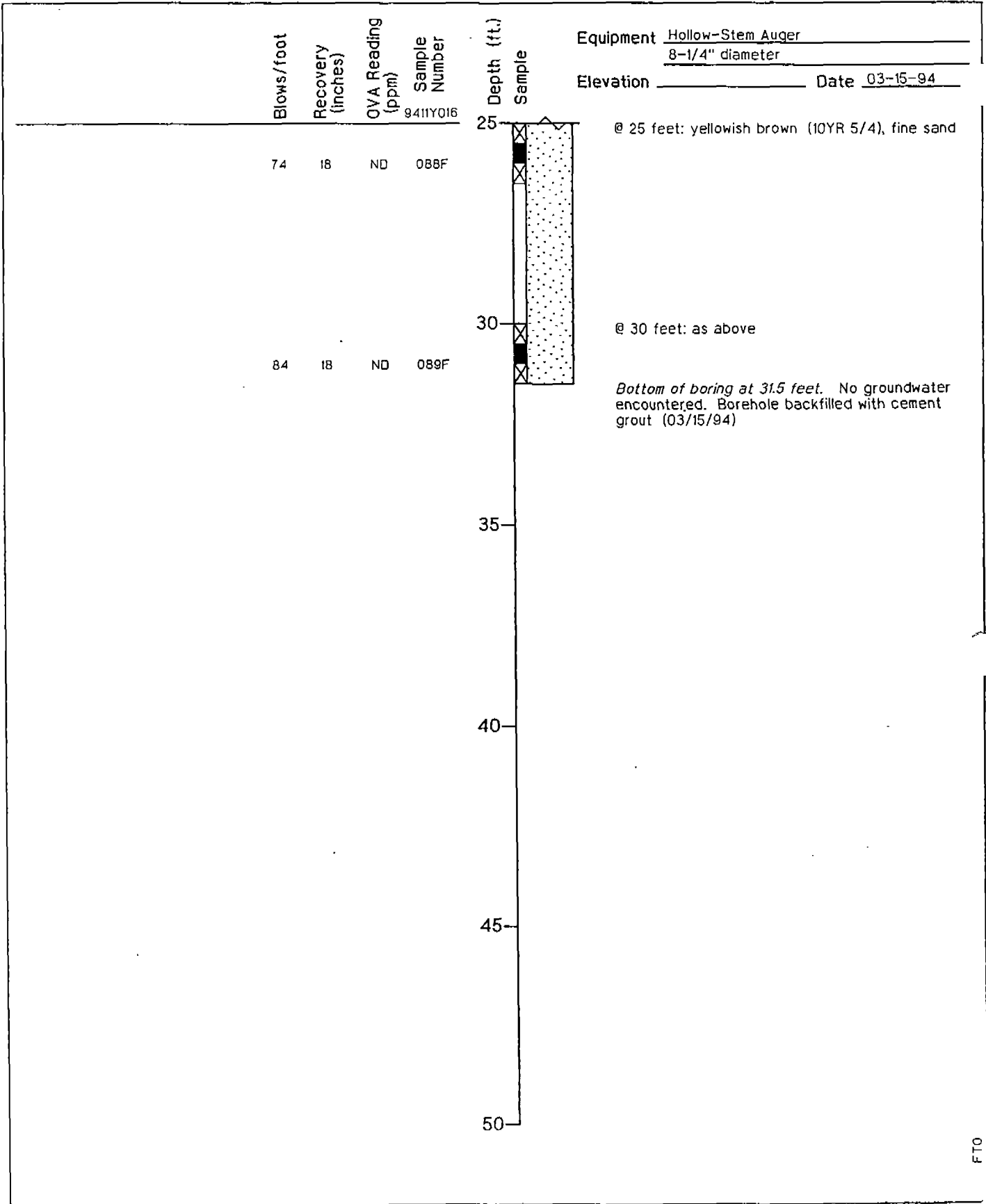

FTO



Harding Lawson Associates
 Engineering and
 Environmental Services

Log of Boring SB-16-25
 Site 16 - Pete's Pond Extension
 Volume II-RI, Basewide RI/FS
 Fort Ord, California

PLAT

B26

DRAWN	JOB NUMBER	APPROVED	DATE	REVISED DATE
LRH	23366 041711	REA	04/94	04/29/94

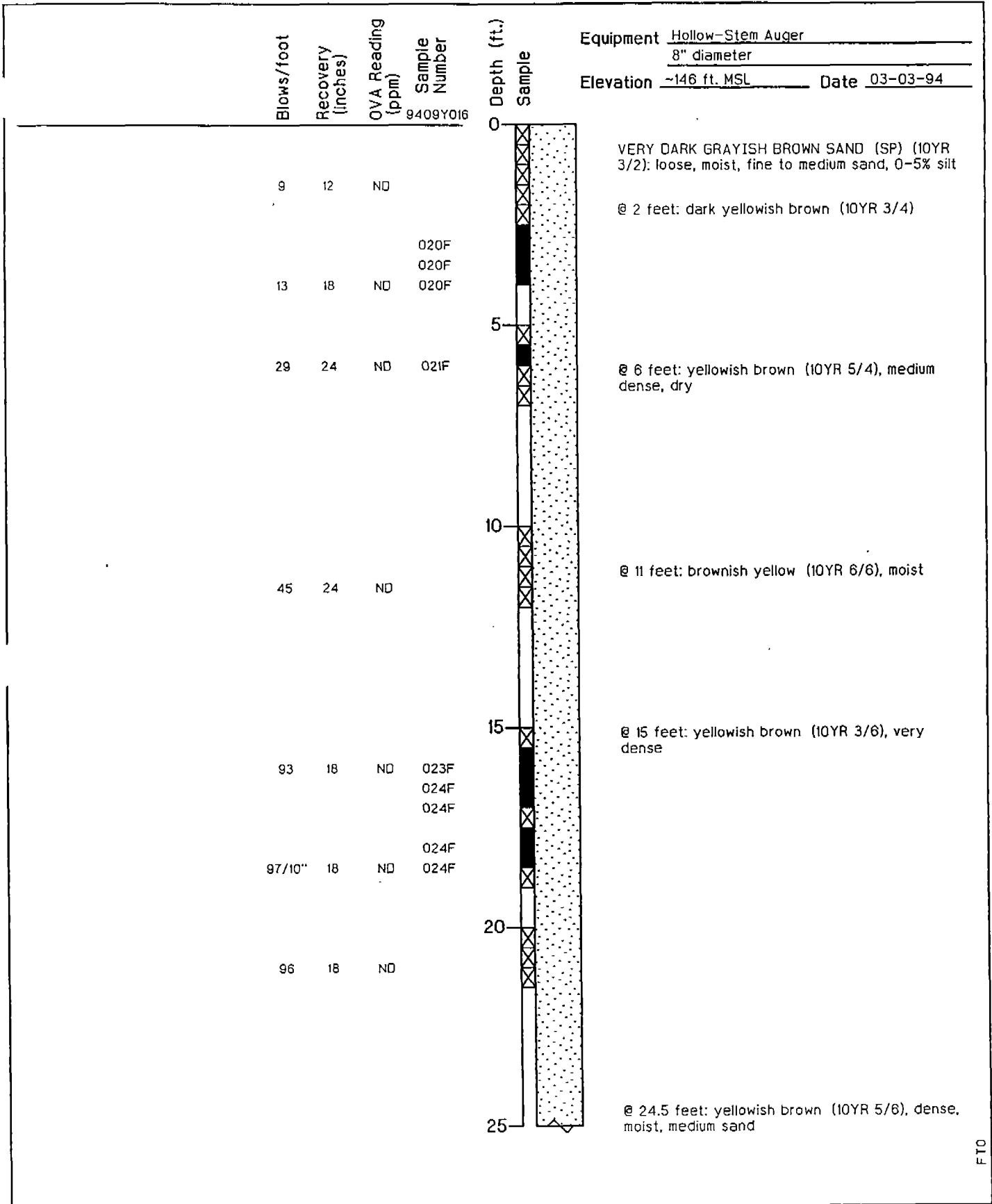

FTO

PLATE



Harding Lawson Associates
Engineering and
Environmental Services

Log of Boring SB-18-26
Site 16 - Pete's Pond Extension
Volume II-RI, Basewide RI/FS
Fort Ord, California

B27

DRAWN	JOB NUMBER	APPROVED	DATE	REVISED DATE
LRH	23366 041711	RFM	03/94	04/29/94

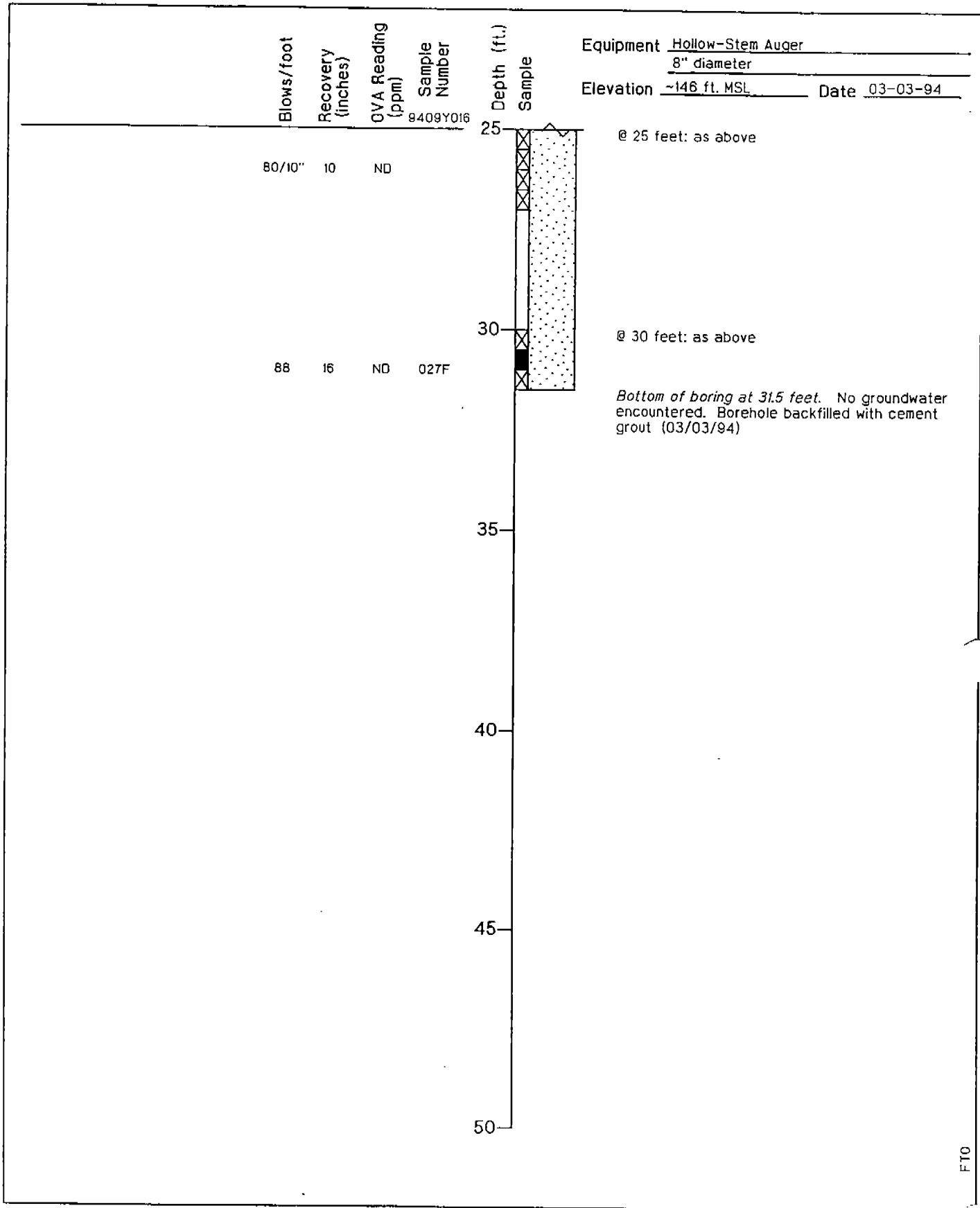

Harding Lawson Associates
Engineering and
Environmental Services

Log of Boring SB-16-26
Site 16 - Pete's Pond Extension
Volume II-RI, Basewide RI/FS
Fort Ord, California

PLAT

B27

DRAWN: LRH
JOB NUMBER: 23366 041711

APPROVED: *RLM*

DATE: 03/94

REVISED DATE: 04/29/94

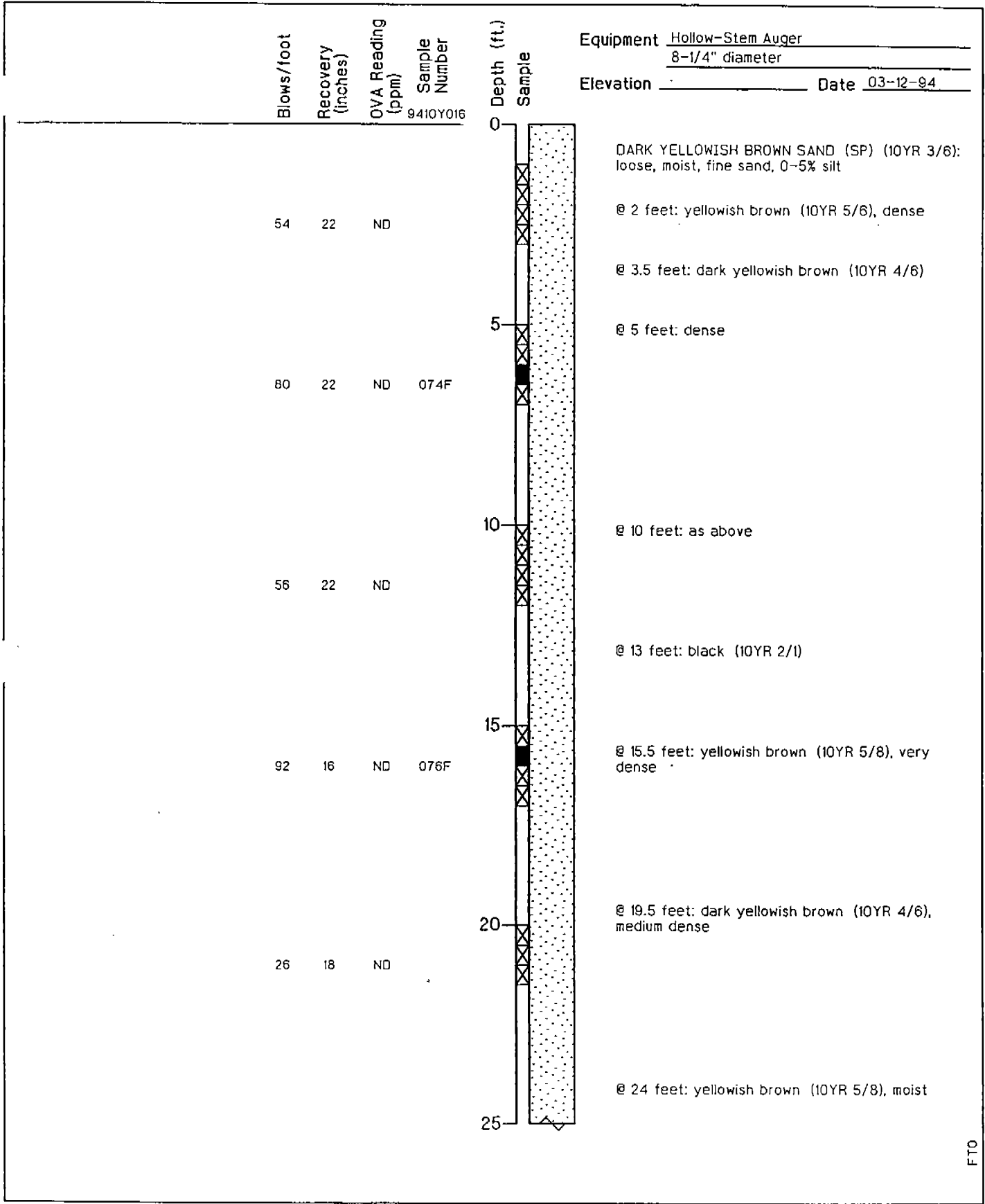

Harding Lawson Associates
Engineering and Environmental Services

Log of Boring SB-16-27
Site 16 - Pete's Pond Extension
Volume II-RI, Basewide RI/FS
Fort Ord, California

PLATE

B28

DRAWN: LRH
JOB NUMBER: 23366 041711

APPROVED: *RFM*

DATE: 04/94

REVISED DATE: 04/29/94

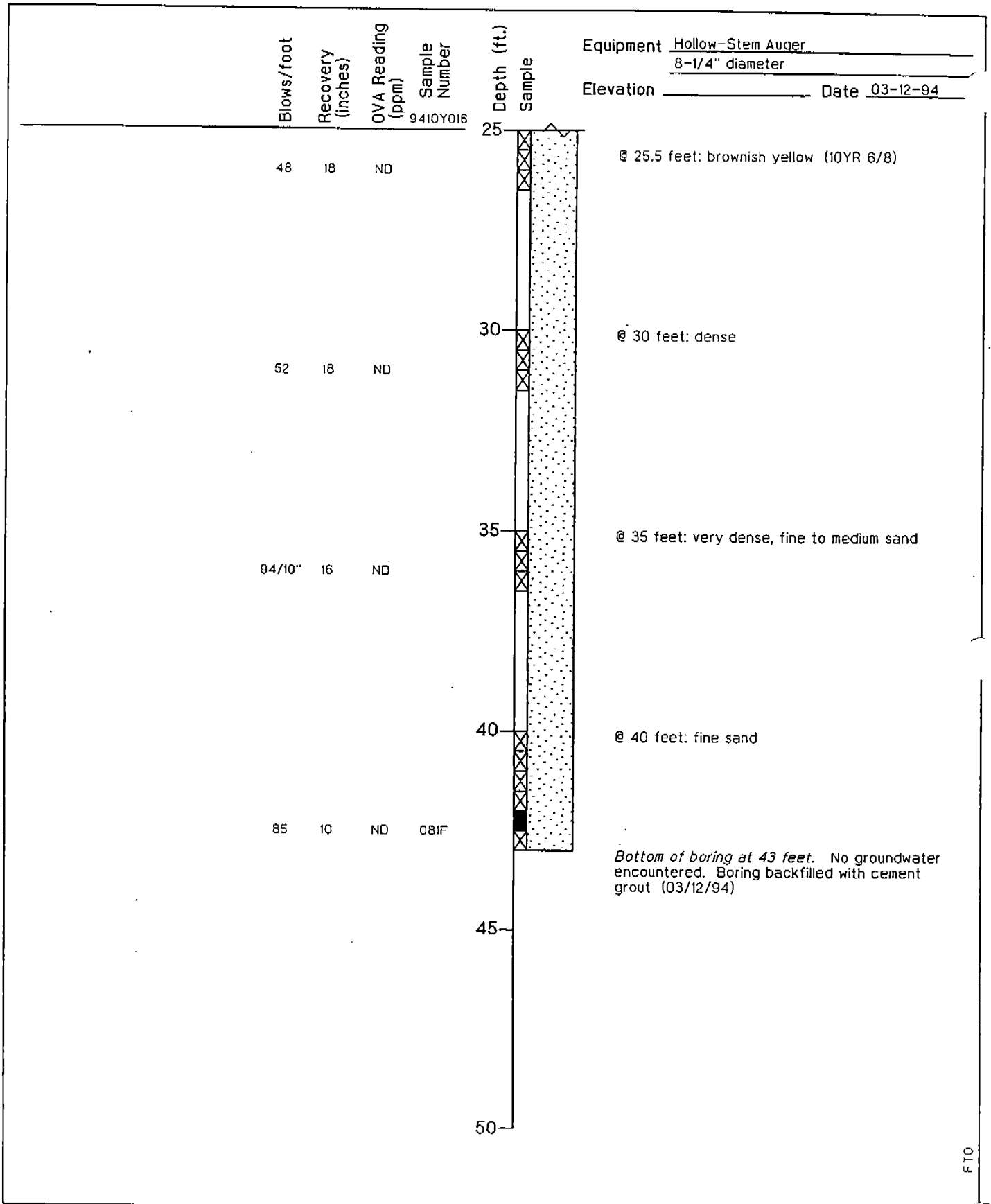

Harding Lawson Associates
Engineering and Environmental Services

Log of Boring SB-16-27
Site 16 - Pete's Pond Extension
Volume II-RI, Basewide RI/FS
Fort Ord, California

PLAT

B28

DRAWN: LRH
JOB NUMBER: 23366 041711

APPROVED: *RLM*

DATE: 04/94

REVISED DATE: 04/29/94

Blows/foot
Recovery (inches)
OVA Reading (ppm)
Sample Number

Depth (ft.)
Sample

Equipment Hollow-Stem Auger
8" diameter
Elevation -136 ft. MSL Date 03-01-94

9409Y016

32	24	ND	015F
29	24	ND	016F
44	24	ND	

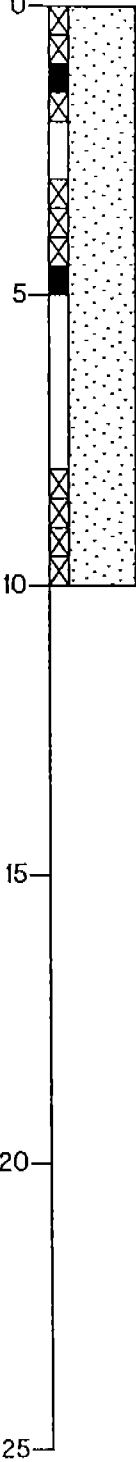

DARK YELLOWISH BROWN SAND (SP) (10YR 3/6):
loose, dry, fine to medium sand
@ 1 foot: very dark brown (10YR 2/2), medium
dense, moist, 0-5% silt

@ 4 feet: as above

@ 8.5 feet: yellowish brown (10YR 5/8)

*Bottom of boring at 10 feet. No groundwater
encountered. Borehole backfilled with cement
grout (03/01/94)*

FTO



Harding Lawson Associates
Engineering and
Environmental Services

Log of Boring SB-18-28
Site 16 - Pete's Pond Extension
Volume II-RI, Basewide RI/FS
Fort Ord, California

PLATE

B29

DRAWN	JOB NUMBER	APPROVED	DATE	REVISED DATE
BWH	23366 041711	<i>Rfm</i>	03/94	04/29/94

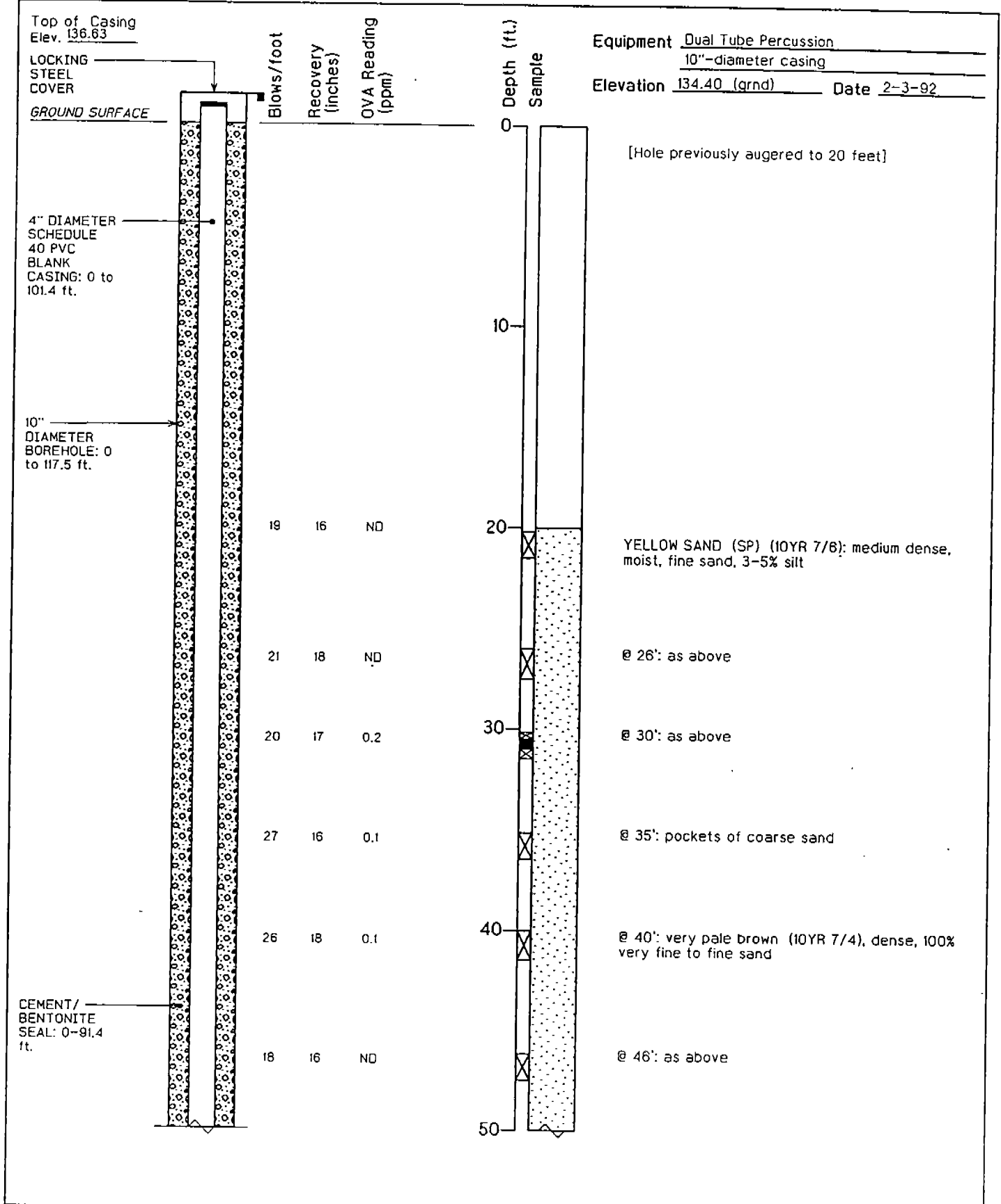

Harding Lawson Associates
 Engineering and Environmental Services

Log of Boring and Well Completion MW-16-01-A
 Site Characterization
 Site 16 - DOL Maintenance Yard, Pete's Pond
 Fort Ord, California

PLATE

B31

DRAWN GTG	JOB NUMBER 10776 687	APPROVED <i>E M</i>	DATE 12/92	REVISED DATE
--------------	-------------------------	------------------------	---------------	--------------

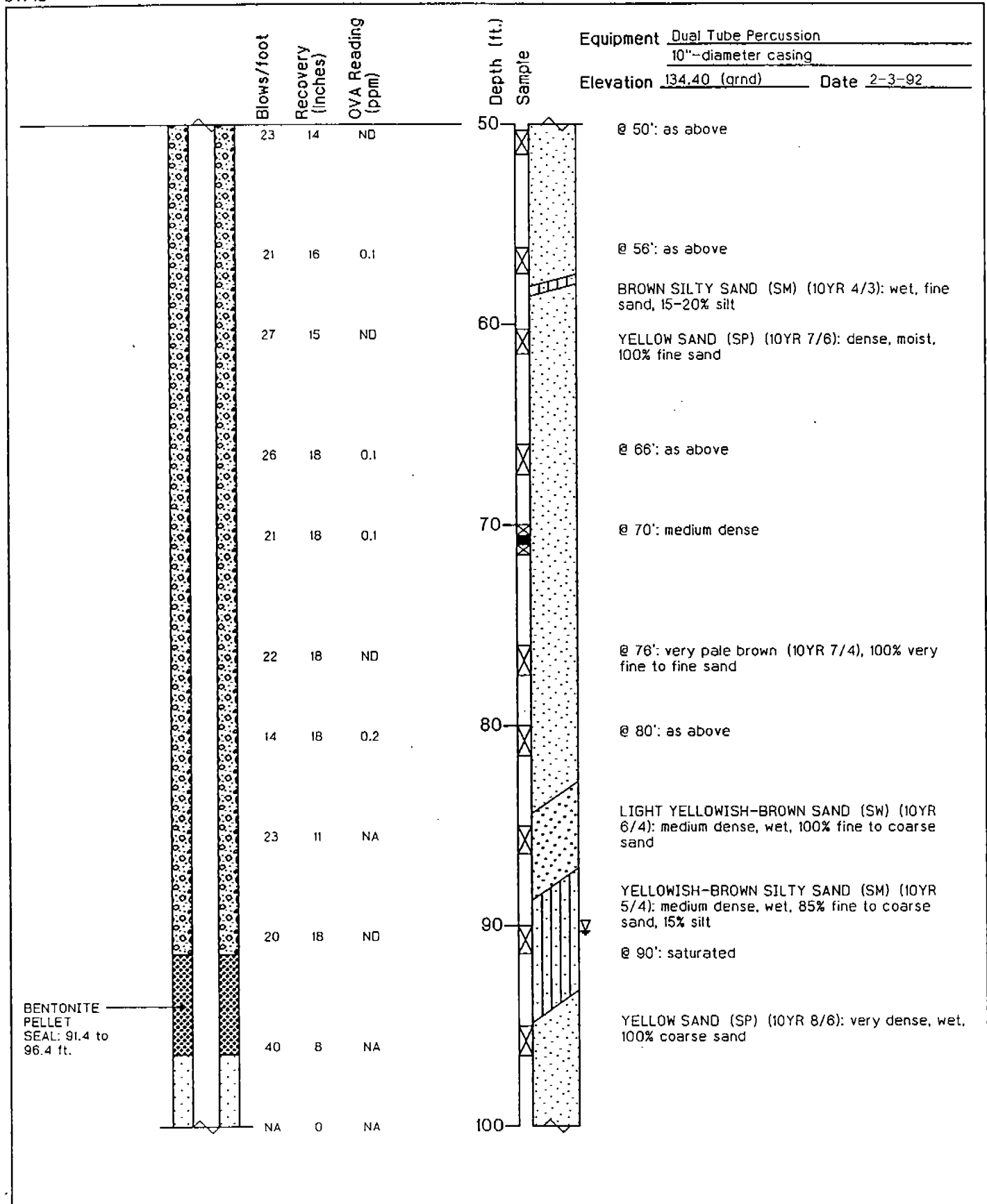

Harding Lawson Associates
Engineering and Environmental Services

Log of Boring and Well Completion MW-16-01-A
Site Characterization
Site 16 - DOL Maintenance Yard, Pete's Pond
Fort Ord, California

PLATE

B31

DRAWN GTG	JOB NUMBER 10776 687	APPROVED <i>[Signature]</i>	DATE 12/92	REVISED DATE
--------------	-------------------------	--------------------------------	---------------	--------------

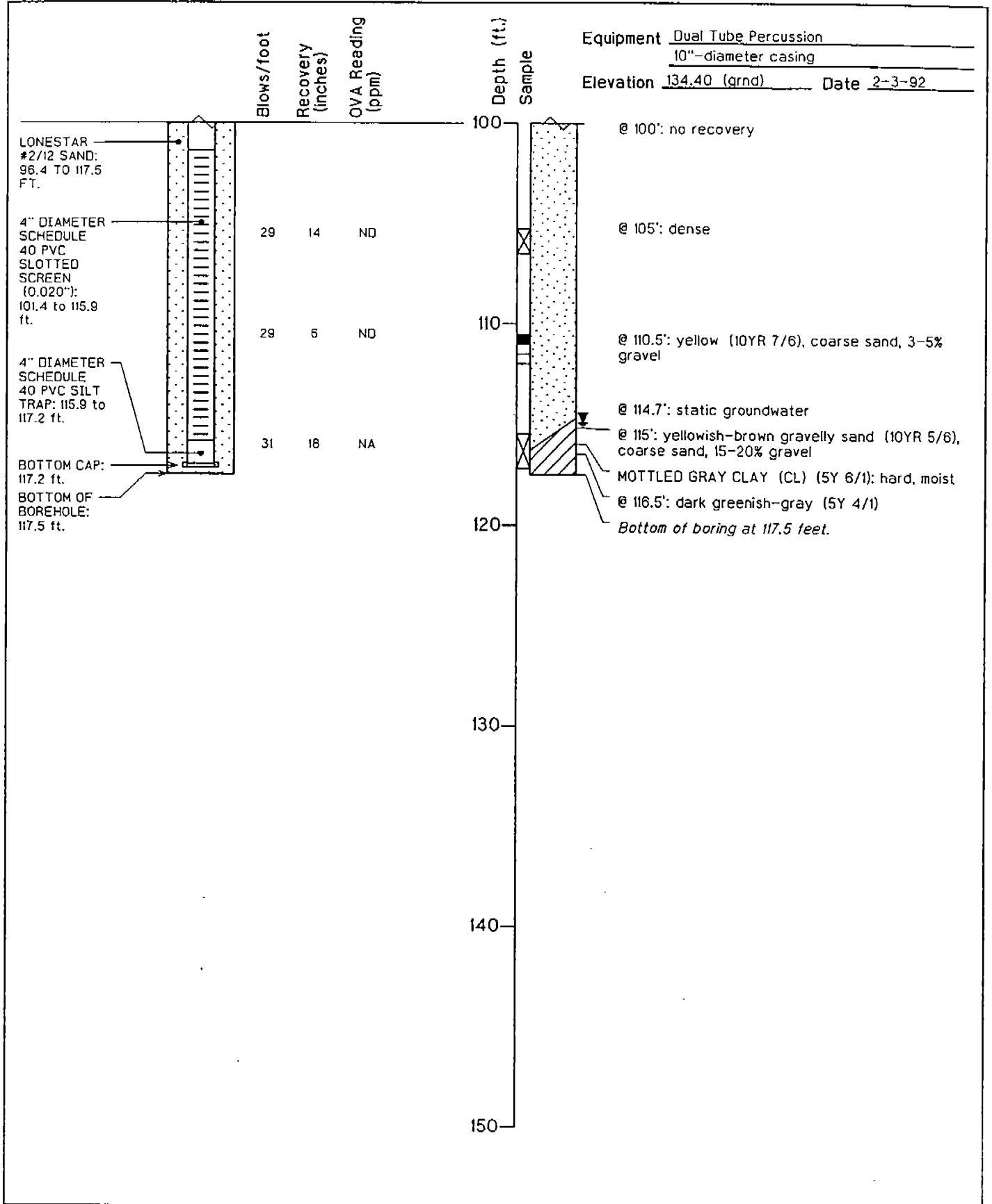

Harding Lawson Associates
Engineering and Environmental Services

Log of Boring and Well Completion MW-18-01-A
Site Characterization
Site 16 - DOL Maintenance Yard, Pete's Pond
Fort Ord, California

PLATE

B31

DRAWN	JOB NUMBER	APPROVED	DATE	REVISED DATE
GTG	10776 687	<i>GTG</i>	12/92	

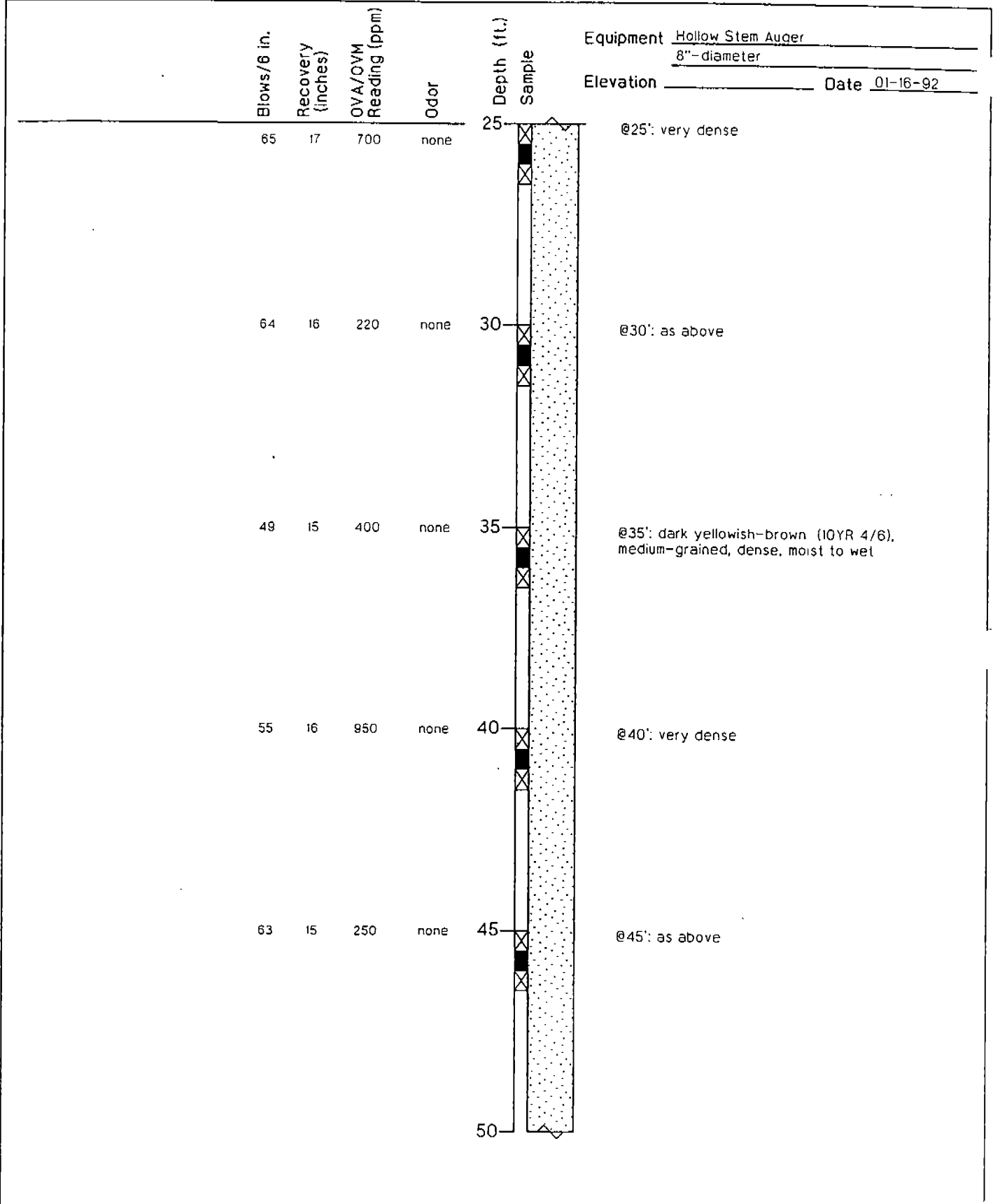

Harding Lawson Associates
 Engineering and
 Environmental Services

Log of Boring SB-17-01
 Site Characterization
 Site 17 - 1400 Block Motor Pool
 Fort Ord, California

PLATE

B32

DRAWN GTG	JOB NUMBER 10776 694	APPROVED <i>LB</i>	DATE 03/93	REVISED DATE
--------------	-------------------------	-----------------------	---------------	--------------

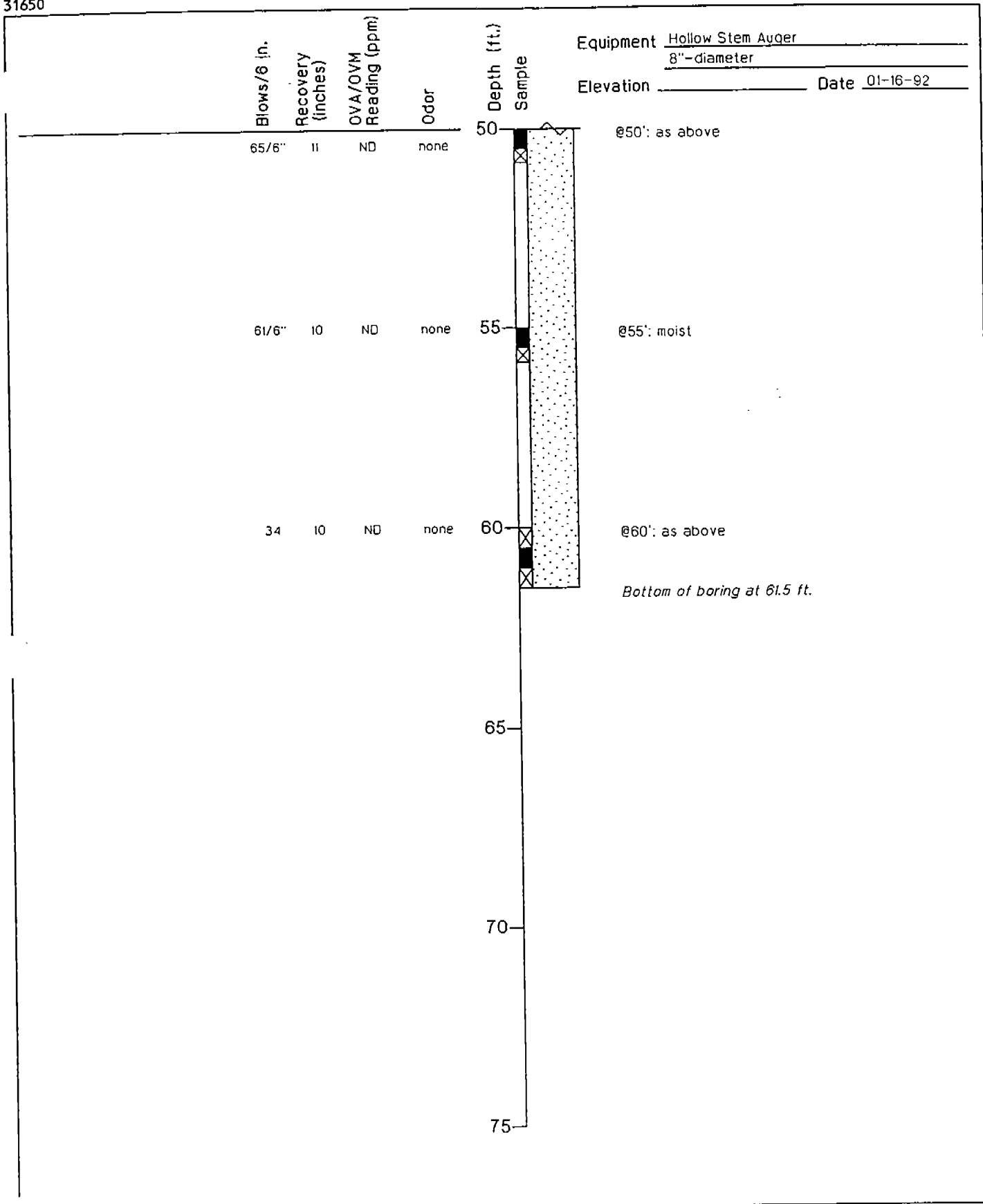

Harding Lawson Associates
Engineering and
Environmental Services

Log of Boring SB-17-01
Site Characterization
Site 17 - 1400 Block Motor Pool
Fort Ord, California

PLATE

B32

DRAWN GTG	JOB NUMBER 10776 694	APPROVED <i>[Signature]</i>	DATE 03/93	REVISED DATE
--------------	-------------------------	--------------------------------	---------------	--------------

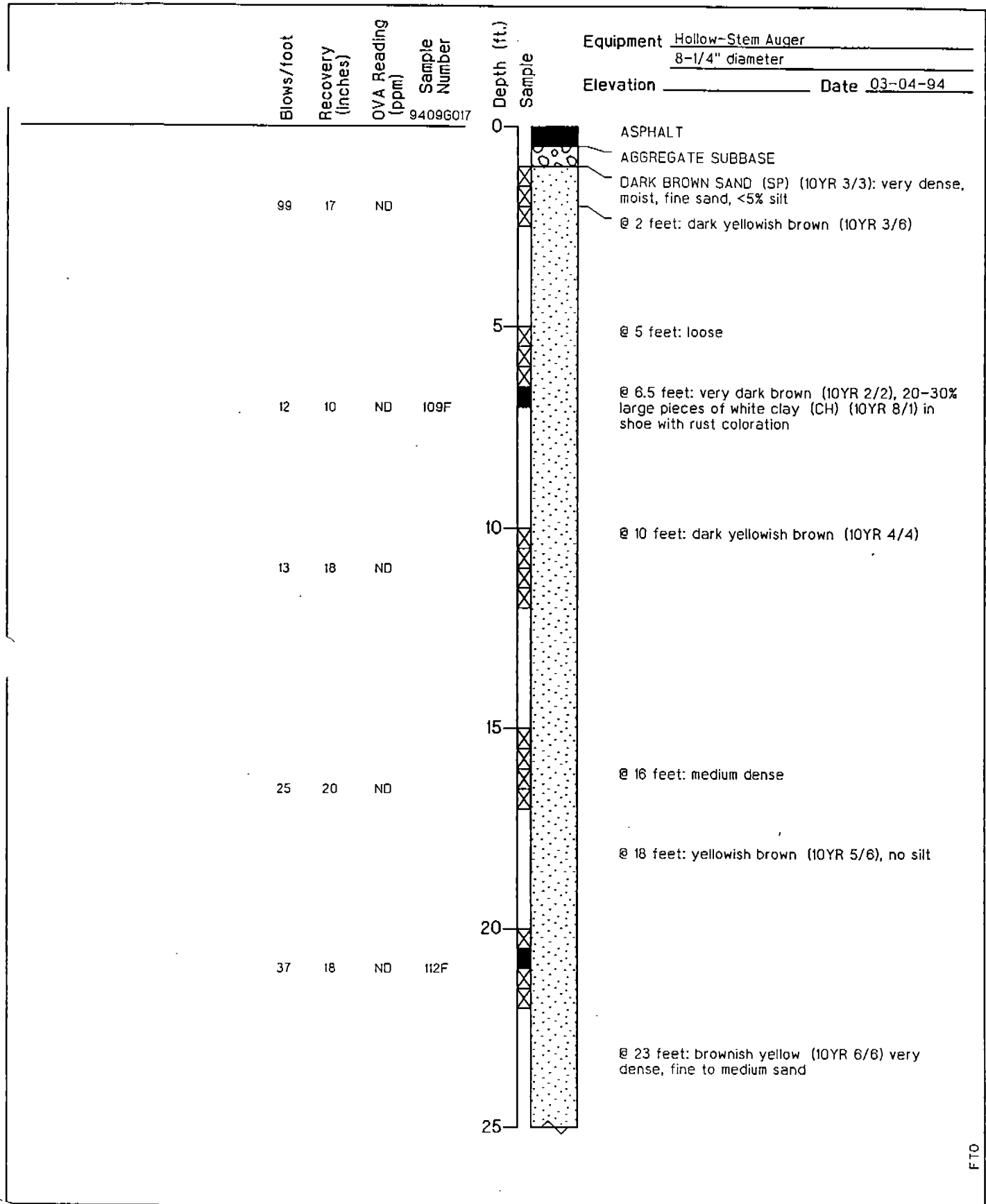

FTO



Harding Lawson Associates
Engineering and Environmental Services

Log of Boring SB-17-03
Site 17 - Disposal Area
Volume II-RI, Basewide RI/FS
Fort Ord, California

PLATE

B34

DRAWN	JOB NUMBER	APPROVED	DATE	REVISED DATE
LRH	23366 041711	<i>RFA</i>	03/94	04/29/94

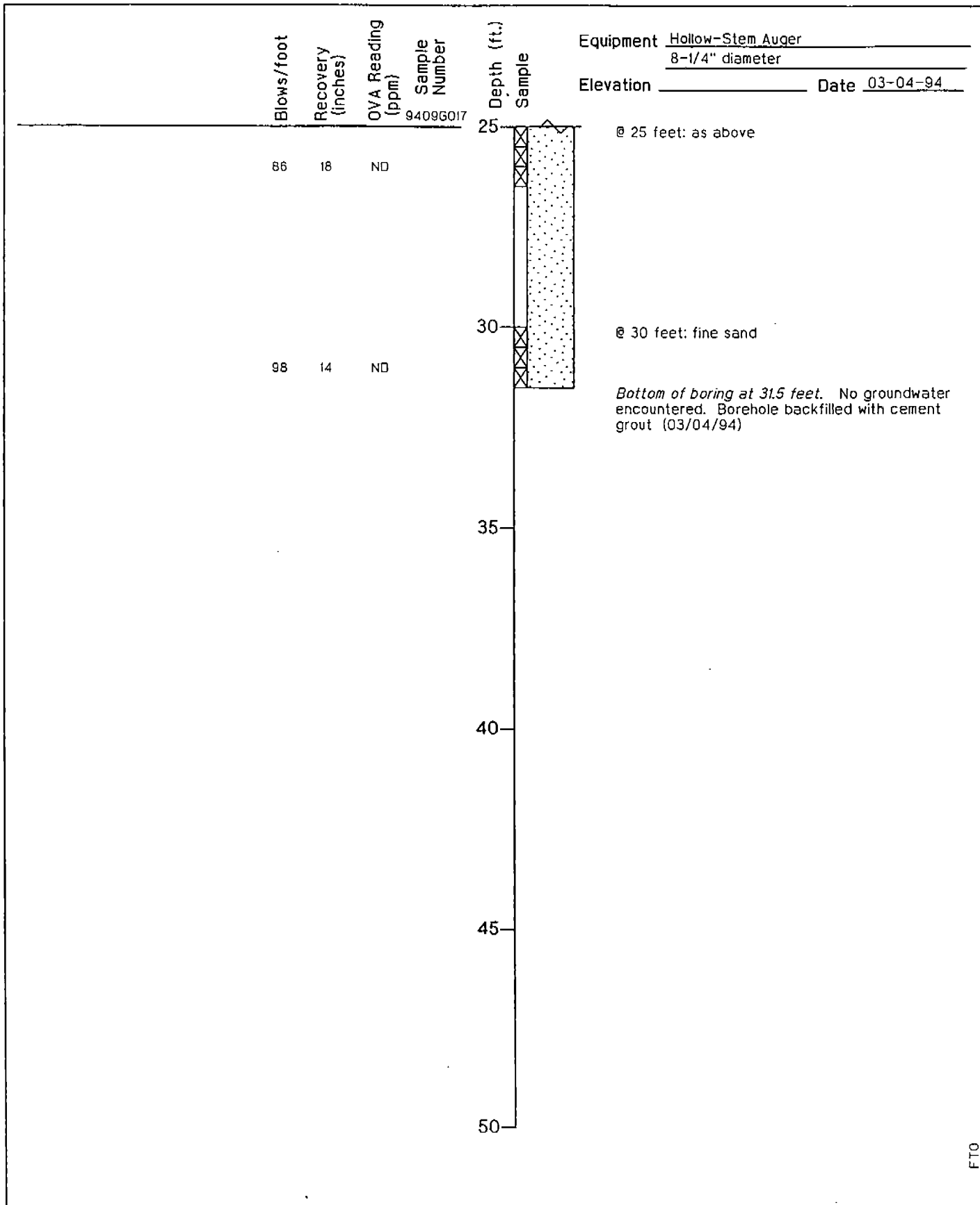

FTO



Harding Lawson Associates
Engineering and
Environmental Services

Log of Boring SB-17-03
Site 17 - Disposal Area
Volume II-RI, Basewide RI/FS
Fort Ord, California

PLAT

B34

DRAWN	JOB NUMBER	APPROVED	DATE	REVISED DATE
LRH	23366 041711	RFM	03/94	04/29/94

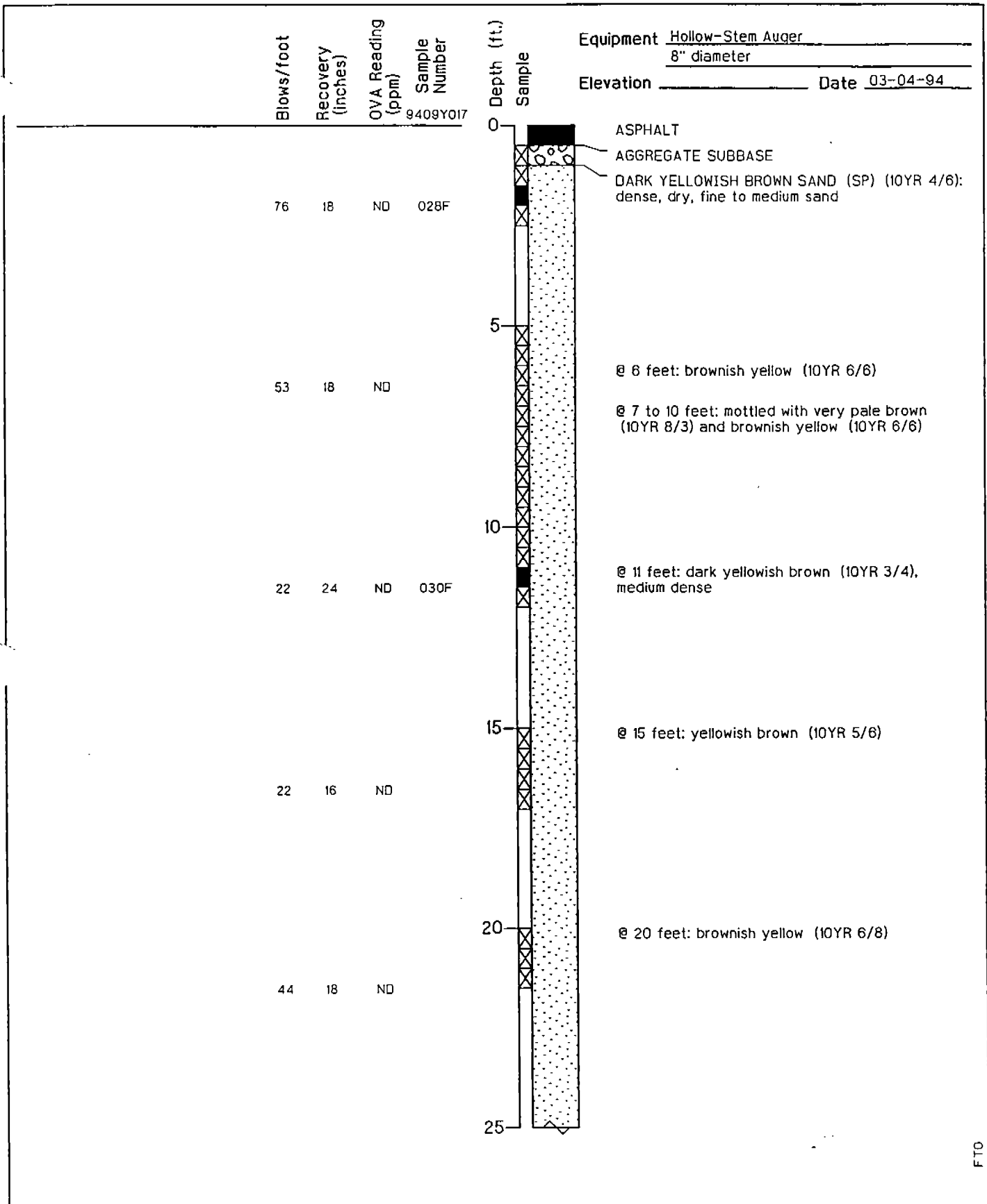

F.T.O.



Harding Lawson Associates
 Engineering and
 Environmental Services

Log of Boring SB-17-04
 Site 17 - Disposal Area
 Volume II-RI, Basewide RI/FS
 Fort Ord, California

PLATE

B35

DRAWN	JOB NUMBER	APPROVED	DATE	REVISED DATE
LRH	23366 041711	R FM	03/94	04/29/94

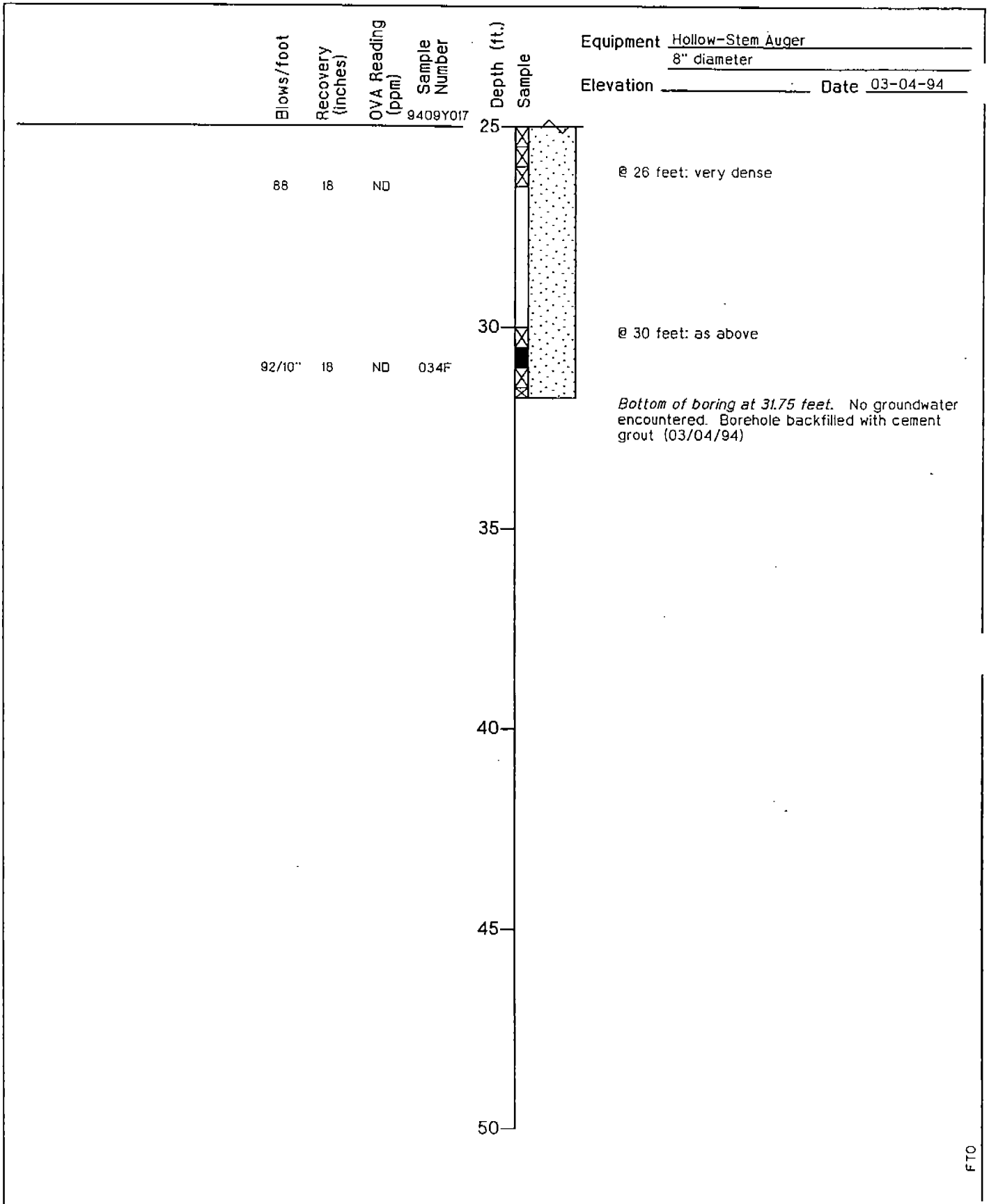

Harding Lawson Associates
Engineering and
Environmental Services

Log of Boring SB-17-04
Site 17 - Disposal Area
Volume II-RI, Basewide RI/FS
Fort Ord, California

PLAT

B35

DRAWN: LRH
JOB NUMBER: 23366 041711

APPROVED: RFM

DATE: 03/94

REVISED DATE: 04/29/94

Blows/foot
Recovery (inches)
OVA Reading (ppm)
Sample Number

Depth (ft.)
Sample

Equipment Hollow-Stem Auger
8-1/4" diameter
Elevation _____ Date 03-07-94

Blows/foot	Recovery (inches)	OVA Reading (ppm)	Sample Number
			9410G017
132	22	ND	
68	22		
61	20	ND	
69	16		117F
74/6"	11	ND	
105	16	ND	

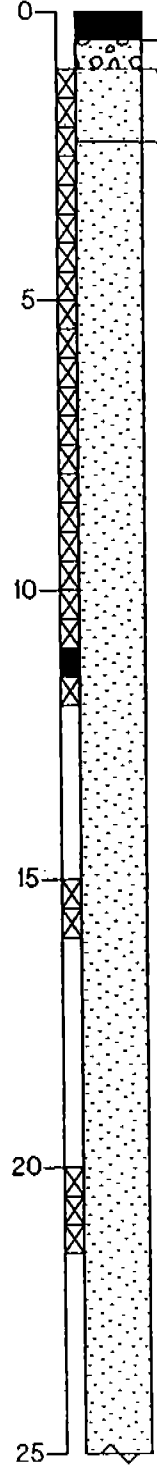

ASPHALT
OLIVE GRAVEL WITH SAND (GW) (5Y 4/4): dense, moist, 1/4-3/4" subangular gravel, 30% fine sand
DARK YELLOWISH BROWN SAND (SP) (10YR 3/4): very dense, moist, fine sand, 10-15% silt
@ 2.5 feet: brownish yellow (10YR 6/6): dense, <5% silt

@ 11 feet: no silt
@ 15 feet: as above
@ 20 feet: as above

FTO



Harding Lawson Associates
Engineering and Environmental Services

Log of Boring SB-17-05
Site 17 - Disposal Area
Volume II-RI, Basewide RI/FS
Fort Ord, California

PLATE

B36

DRAWN LRH	JOB NUMBER 23366 041711	APPROVED <i>RFM</i>	DATE 03/94	REVISED DATE
--------------	----------------------------	------------------------	---------------	--------------

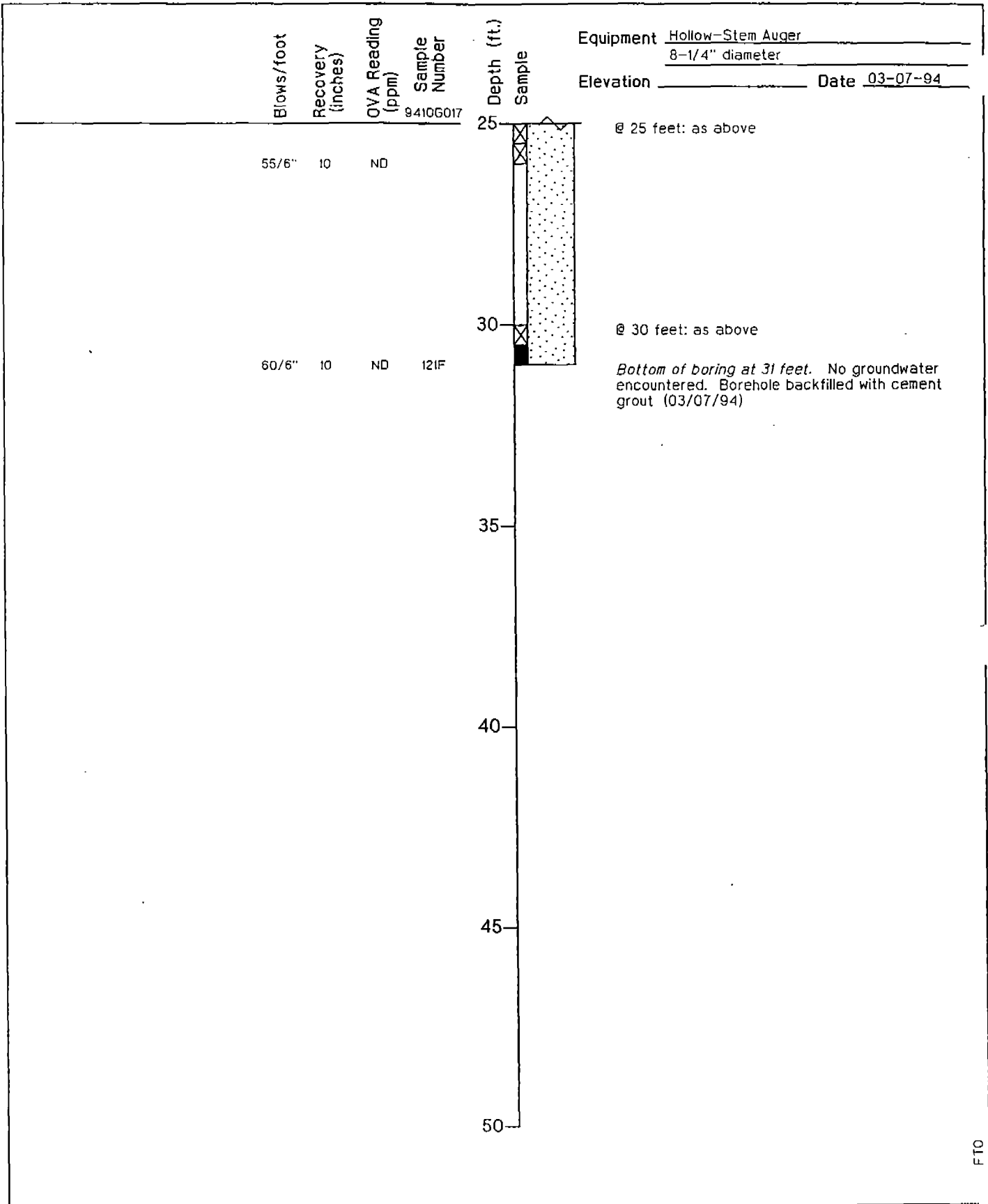

FTD



Harding Lawson Associates
Engineering and
Environmental Services

Log of Boring SB-17-05
Site 17 - Disposal Area
Volume II-RI, Basewide RI/FS
Fort Ord, California

PLAT

B36

DRAWN	JOB NUMBER	APPROVED	DATE	REVISED DATE
LRH	23366 041711	RFM	03/94	

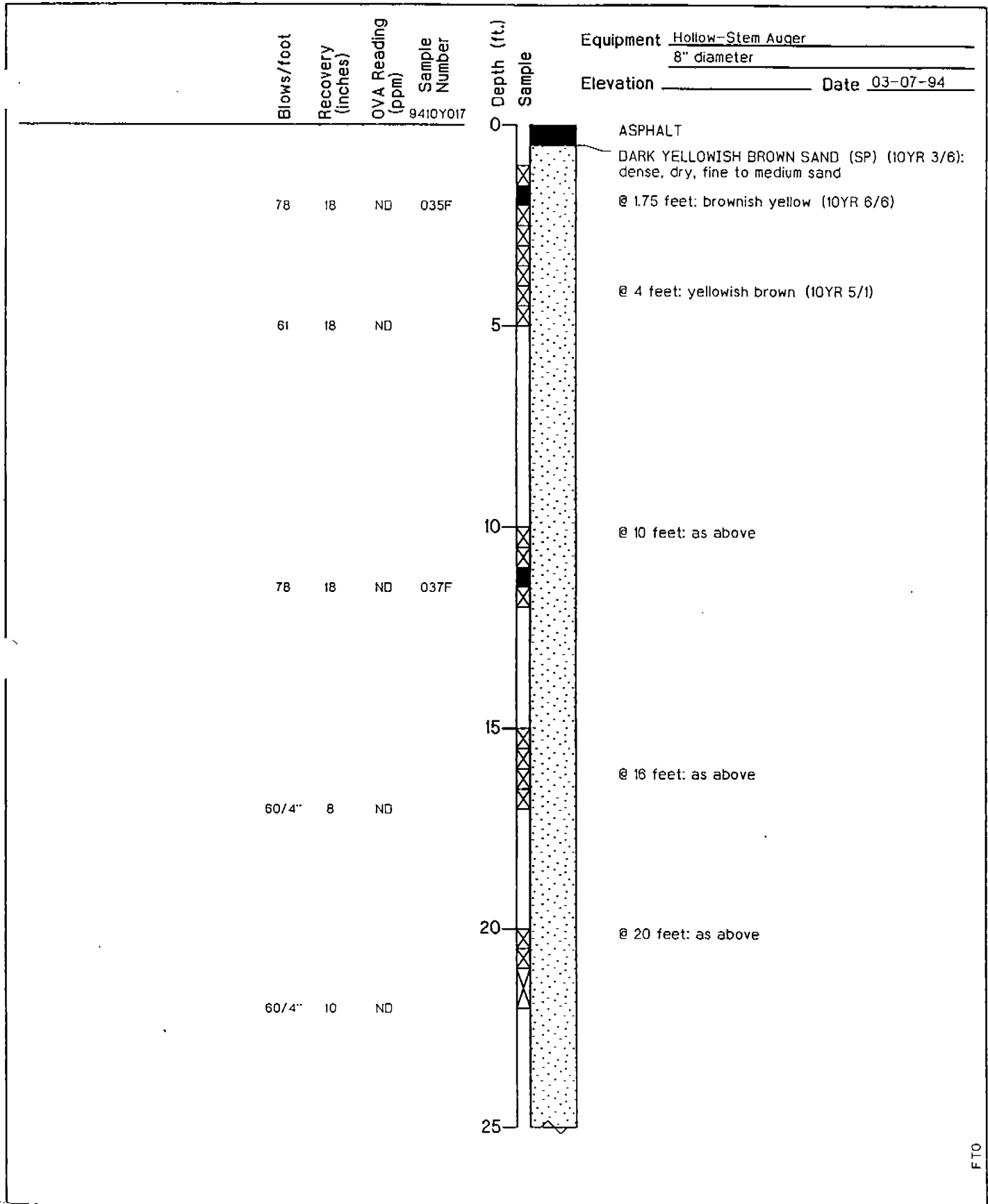

F T O



Harding Lawson Associates
Engineering and
Environmental Services

Log of Boring SB-17-08
Site 17 - Disposal Area
Volume II-RI, Basewide RI/FS
Fort Ord, California

PLATE

B37

DRAWN JOB NUMBER
LRH 23366 041711

APPROVED
RFM

DATE
03/94

REVISED DATE
04/28/94

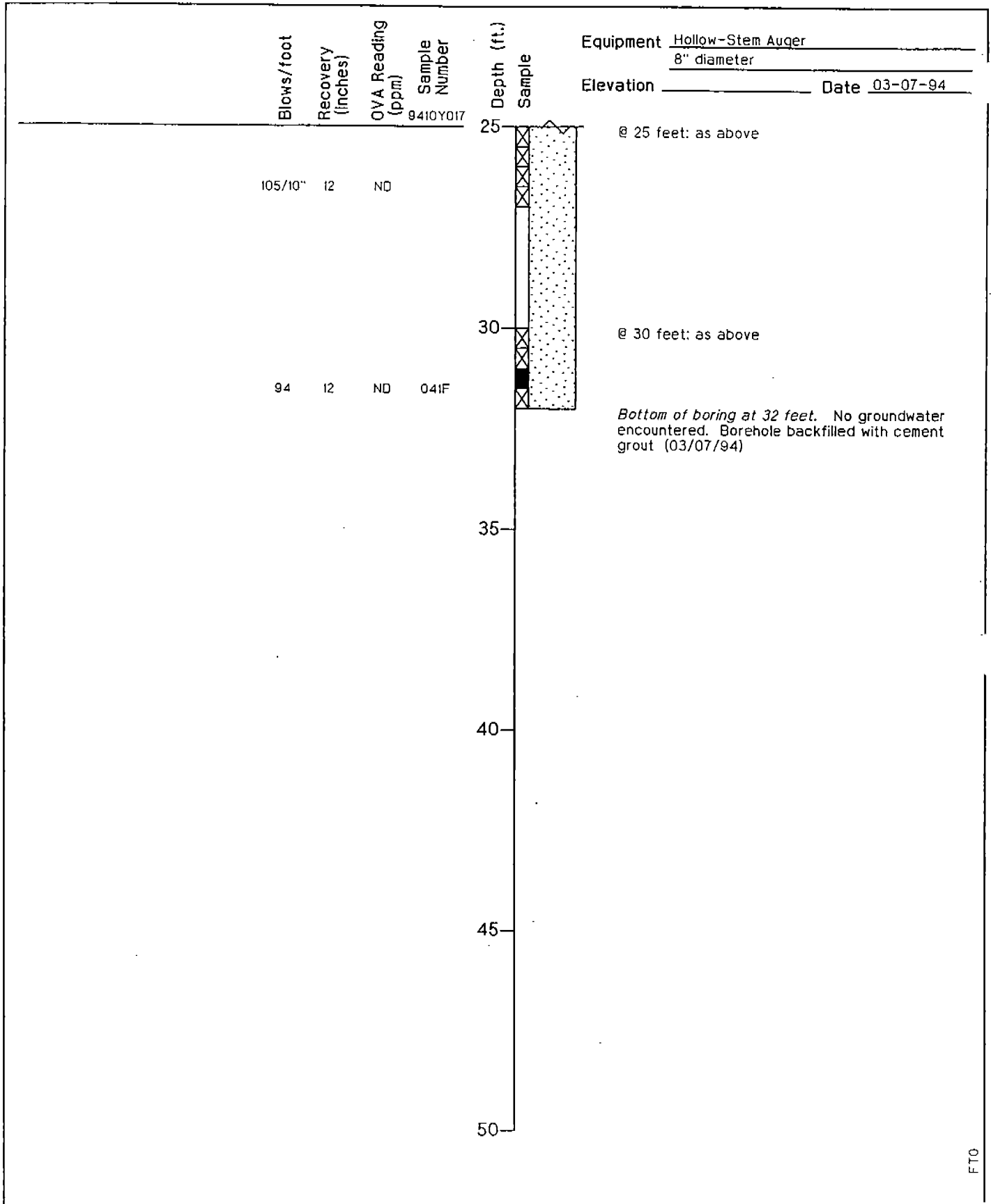

FTO



Harding Lawson Associates
Engineering and Environmental Services

Log of Boring SB-17-06
Site 17 - Disposal Area
Volume II-RI, Basewide RI/FS
Fort Ord, California

PLAT

B37

DRAWN: LRH
JOB NUMBER: 23366 041711

APPROVED: RFA

DATE: 03/94

REVISED DATE: 04/28/94

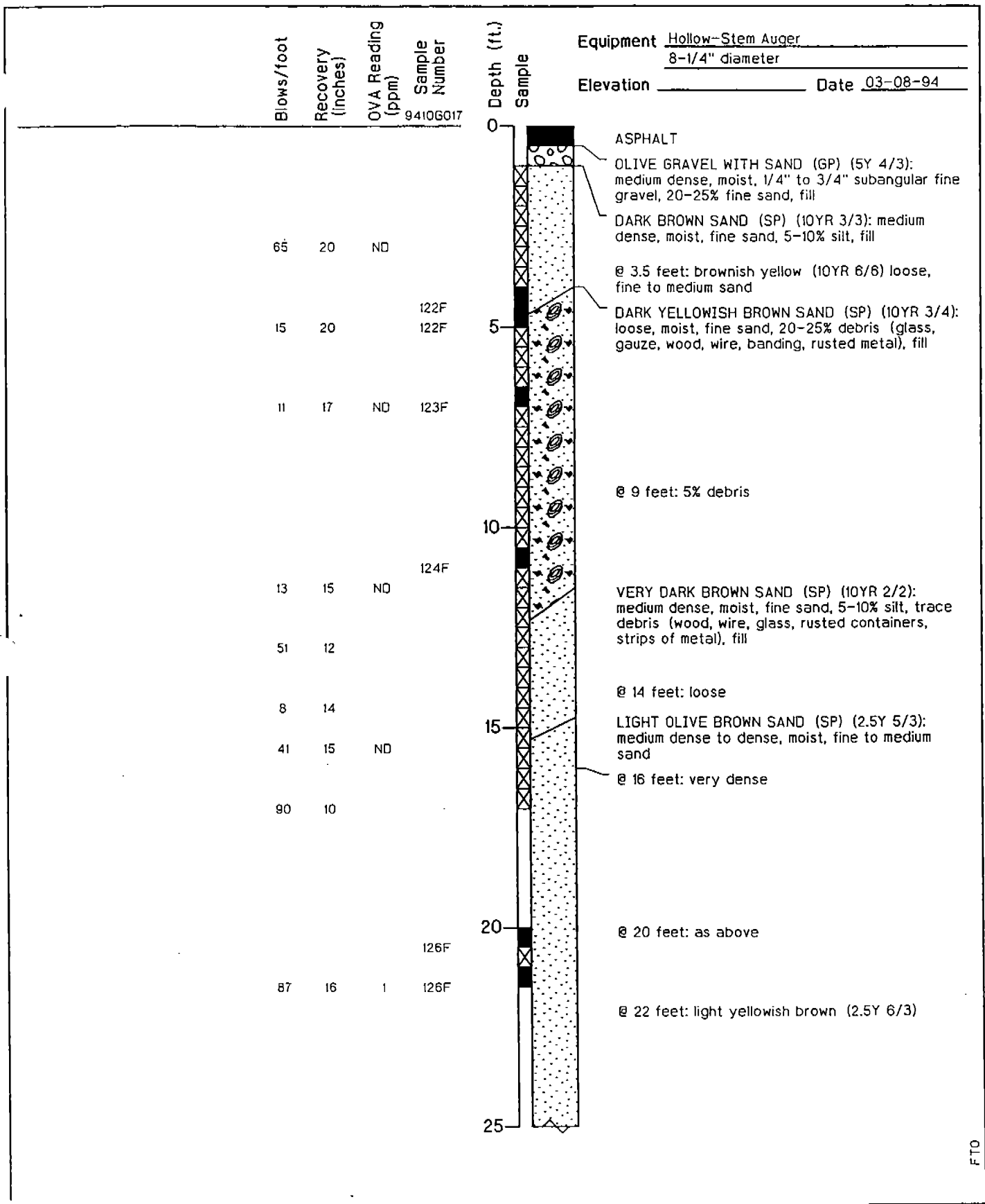

FTO



Harding Lawson Associates
Engineering and Environmental Services

Log of Boring SB-17-07
Site 17 - Disposal Area
Volume II-RI, Basewide RI/FS
Fort Ord, California

PLATE

B38

DRAWN	JOB NUMBER	APPROVED	DATE	REVISED DATE
LRH	23366 041711	<i>RFM</i>	04/94	04/29/94

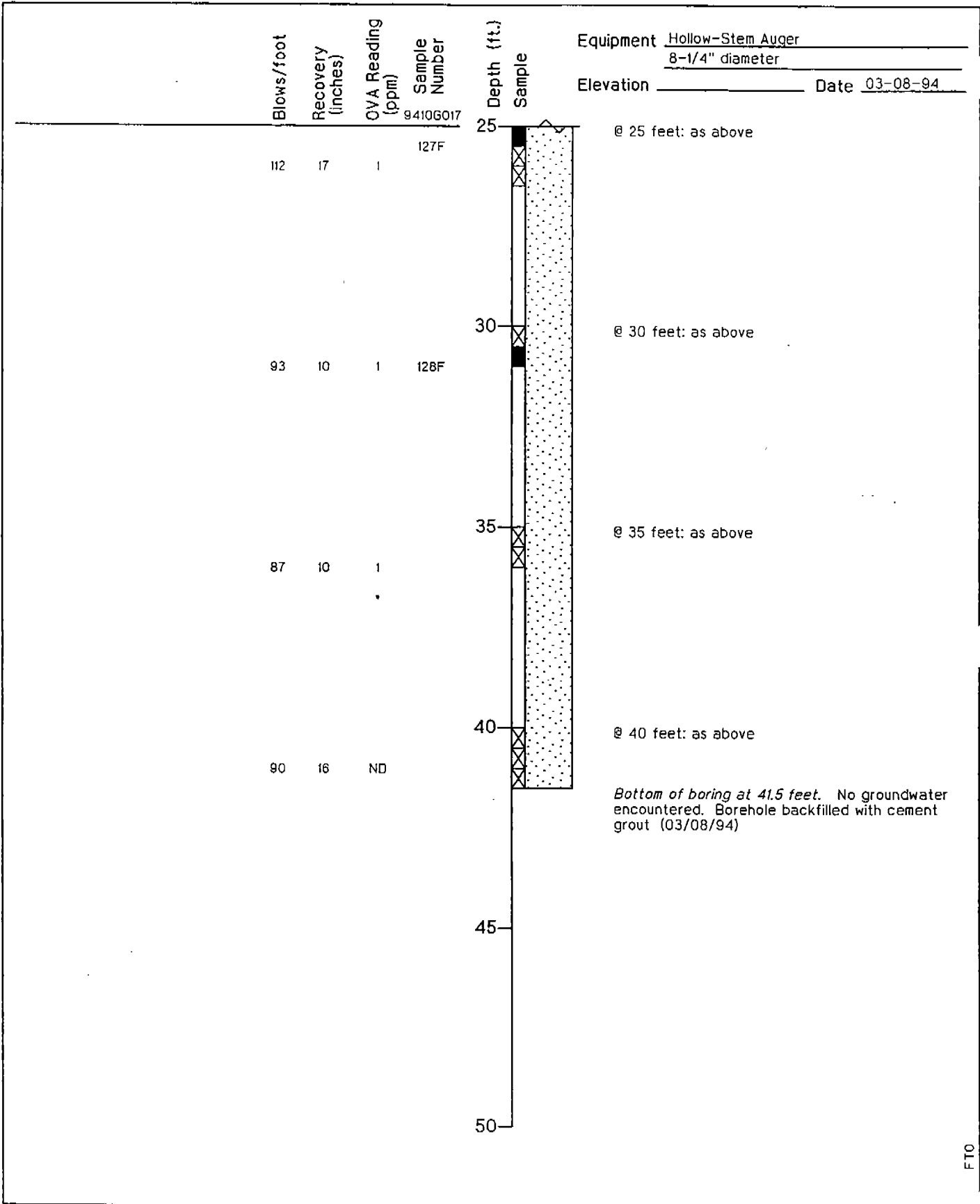

FTO



Harding Lawson Associates
 Engineering and
 Environmental Services

Log of Boring SB-17-07
 Site 17 - Disposal Area
 Volume II-RI, Basewide RI/FS
 Fort Ord, California

PLA1

B38

DRAWN JOB NUMBER
 LRH 23366 041711

APPROVED
RFM

DATE
 04/94

REVISED DATE
 04/29/94

Blows/foot
Recovery (inches)
OVM (ppm)
OVA (ppm)
Sample Number
9410Y017

Equipment Hollow-Stem Auger
3-1/4" diameter
Elevation _____ Date 03-09-94

Blows/foot	Recovery (inches)	OVM (ppm)	OVA (ppm)	Sample Number
53	12	ND	ND	
8	4	ND	ND	
24	4	ND	ND	
	10	ND	ND	
34	10	ND	ND	043F
46	3	ND	ND	
				044F 044F
47	18	ND	ND	
64	20	ND	10	047F
55/6"	14	ND	10	

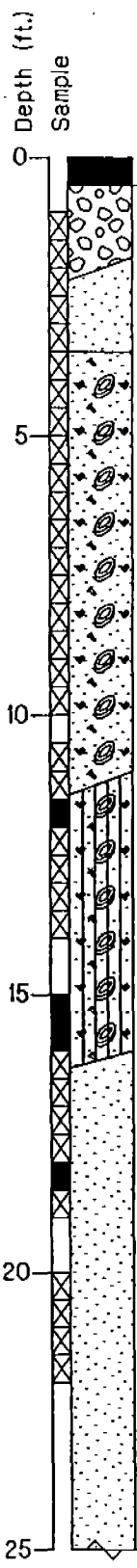

ASPHALT
ASPHALT SUBBASE AGGREGATE
DARK YELLOWISH BROWN SAND (SP) (10YR 3/6): dense, dry, fine sand, fill
DARK YELLOWISH BROWN SAND WITH DEBRIS (SP) (10YR 3/6): loose, dry, fine sand, 15-20% debris (glass, metal, wood)
@ 6 feet: dark brown (10YR 3/3): medium dense, moist, 15-25% debris (broken glass, ceramic, hair or twine)
@ 9 feet: yellowish brown (10YR 5/6) layered with dark brown (10YR 3/3) and black
DARK BROWN SILTY SAND WITH DEBRIS (SM) (10YR 3/3): medium dense, moist, fine sand, 20-35% debris (broken glass, metal, steel cans and tops, 60mm mortar cannister, safety pin cover)
LIGHT OLIVE BROWN SAND (SP) (2.5Y 5/3): medium dense, moist, fine to medium sand
@ 20 feet: light yellowish brown (2.5Y 6/3), very dense

FTO-OVA



Harding Lawson Associates
Engineering and Environmental Services

Log of Boring SB-17-08
Site 17 - Disposal Area
Volume II-RI, Basewide RI/FS
Fort Ord, California

PLATE

B39

DRAWN LRH	JOB NUMBER 23366 041711	APPROVED RFA	DATE 04/94	REVISED DATE
--------------	----------------------------	-----------------	---------------	--------------

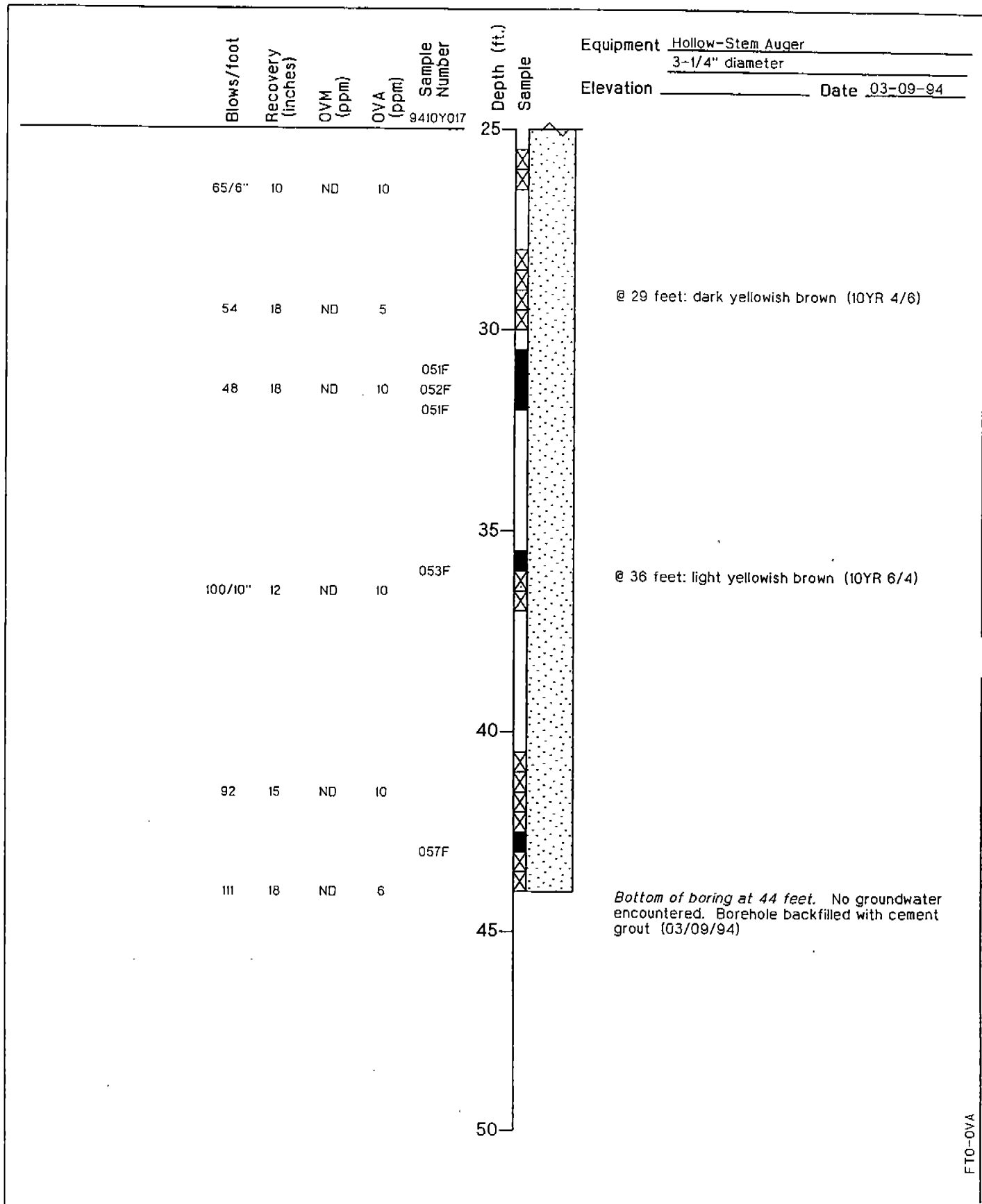

FTO-OVA

	Harding Lawson Associates Engineering and Environmental Services	Log of Boring SB-17-08 Site 17 - Disposal Area Volume II-RI, Basewide RI/FS Fort Ord, California	PLAT B39
	DRAWN LRH JOB NUMBER 23366 041711 APPROVED <i>Rfm</i> DATE 04/94	REVISED DATE	

Blows/foot
Recovery (inches)
OVM (ppm)
OVA (ppm)
Sample Number
9410G017

Equipment Hollow-Stem Auger
8-1/4" diameter
Elevation _____ Date 03-10-94

Blows/foot	Recovery (inches)	OVM (ppm)	OVA (ppm)	Sample Number
59	21	ND	ND	
27	23			
11	10	ND	ND	132F
88	16	ND	ND	
82				
90	20	ND	1	
98	15	ND	ND	135F

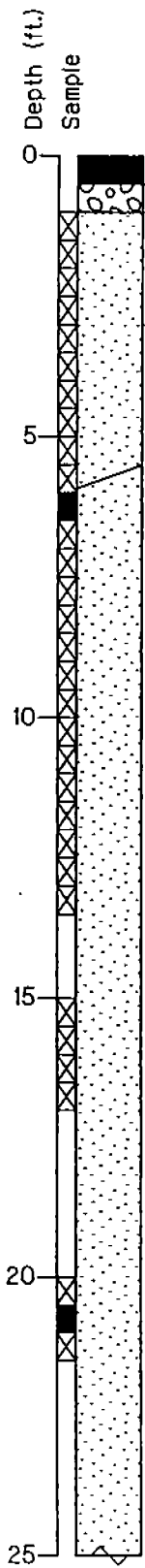

ASPHALT
OLIVE GRAVEL WITH SAND (GP) (5Y 4/3): loose, moist, subangular fine gravel, 20-25% fine sand, fill
DARK YELLOWISH BROWN SAND (SP) (10YR 3/4): medium dense, moist, fine sand, 5-10% silt, fill
@ 3 feet: brownish yellow (10YR 6/6) dense, trace debris (rusted metal)
DARK BROWN SAND (SP) (10YR 3/3): loose, moist, fine sand, <5% silt
@ 8 feet: brownish yellow (10YR 6/6) dense to very dense, fine to medium sand
@ 15 feet: as above
@ 20 feet: as above

FTO-OVA



Harding Lawson Associates
Engineering and
Environmental Services

Log of Boring SB-17-09
Site 17 - Disposal Area
Volume II-RI, Basewide RI/FS
Fort Ord, California

PLATE

B40

DRAWN LRH	JOB NUMBER 23366 041711	APPROVED <i>RFM</i>	DATE 04/94	REVISED DATE 04/29/94
--------------	----------------------------	------------------------	---------------	--------------------------

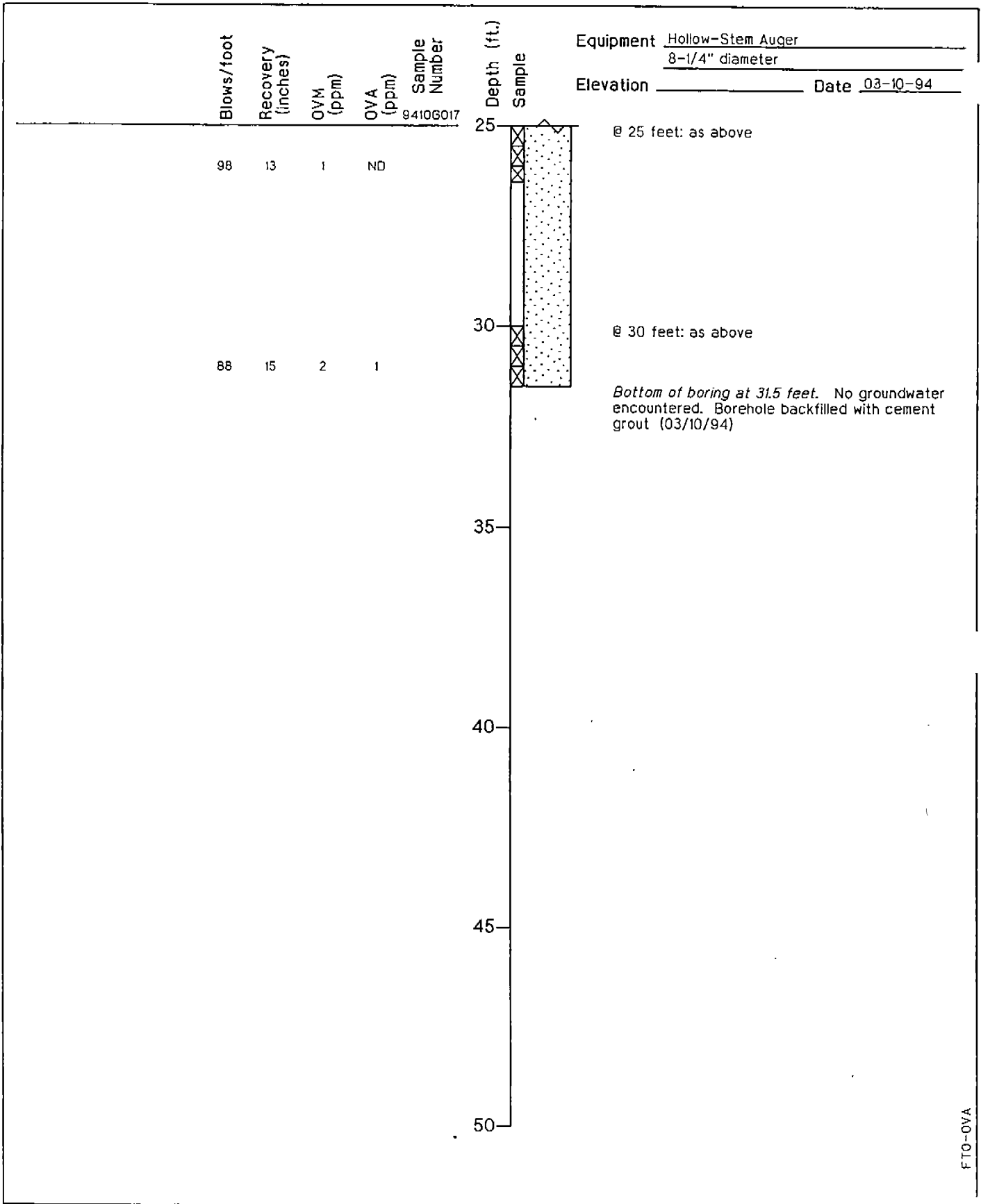

FTO-OVA



Herding Lawson Associates
Engineering and
Environmental Services

Log of Boring SB-17-09
Site 17 - Disposal Area
Volume II-RI, Basewide RI/FS
Fort Ord, California

PLAT

B40

DRAWN: LRH
JOB NUMBER: 23366 041711

APPROVED: *RFM*

DATE: 04/94

REVISED DATE: 04/29/94

Blows/foot
Recovery (inches)
OVM (ppm)
OVA (ppm)
Sample Number
9410Y017

Equipment Hollow-Stem Auger
8" diameter
Elevation _____ Date 03-10-94

Blows/foot	Recovery (inches)	OVM (ppm)	OVA (ppm)	Sample Number
27	20	ND	ND	
17	20	ND	ND	
19	22	ND	5	060F
	14			
13	20	2.5	ND	
	12	2.5	5	
60	20	ND	ND	
68	18	ND	7	

Depth (ft.)
Sample

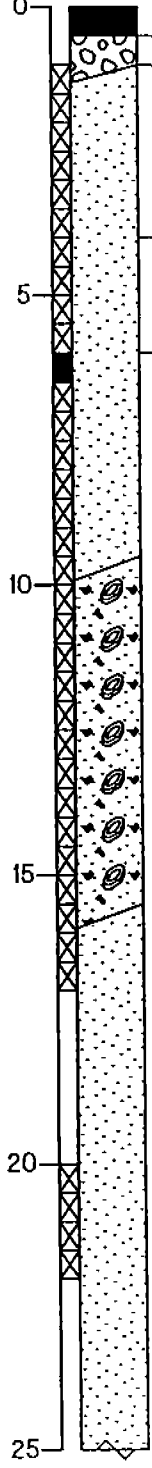

ASPHALT
ASPHALT SUBBASE AGGREGATE
DARK YELLOWISH BROWN SAND (SP) (10YR 3/6):
medium dense, moist, fine sand, 0-5% silt, fill

@ 3.5 feet: yellowish brown (10YR 5/8): loose,
dry, fine to medium sand
@ 4 feet: dark yellowish brown (10YR 3/6)

@ 5.5 feet: yellowish brown (10YR 5/8)
@ 6 feet: dark yellowish brown (10YR 3/6),
intermittent layers of 10-15% debris (broken
glass, ceramic)

VERY DARK BROWN SAND WITH DEBRIS (SP)
(10YR 2/2): loose, dry, fine sand, 0-25% debris
(some non-charred wood, steel)

YELLOWISH BROWN SAND (SP) (10YR 5/8):
dense, moist, fine to medium sand

@ 20 feet: brownish yellow (10YR 6/8)

FT0-OVA



Harding Lawson Associates
Engineering and
Environmental Services

Log of Boring SB-17-10
Site 17 - Disposal Area
Volume II-RI, Basewide RI/FS
Fort Ord, California

PLATE

B41

DRAWN	JOB NUMBER	APPROVED	DATE	REVISED DATE
LRH	23366 041711	<i>RFM</i>	04/94	

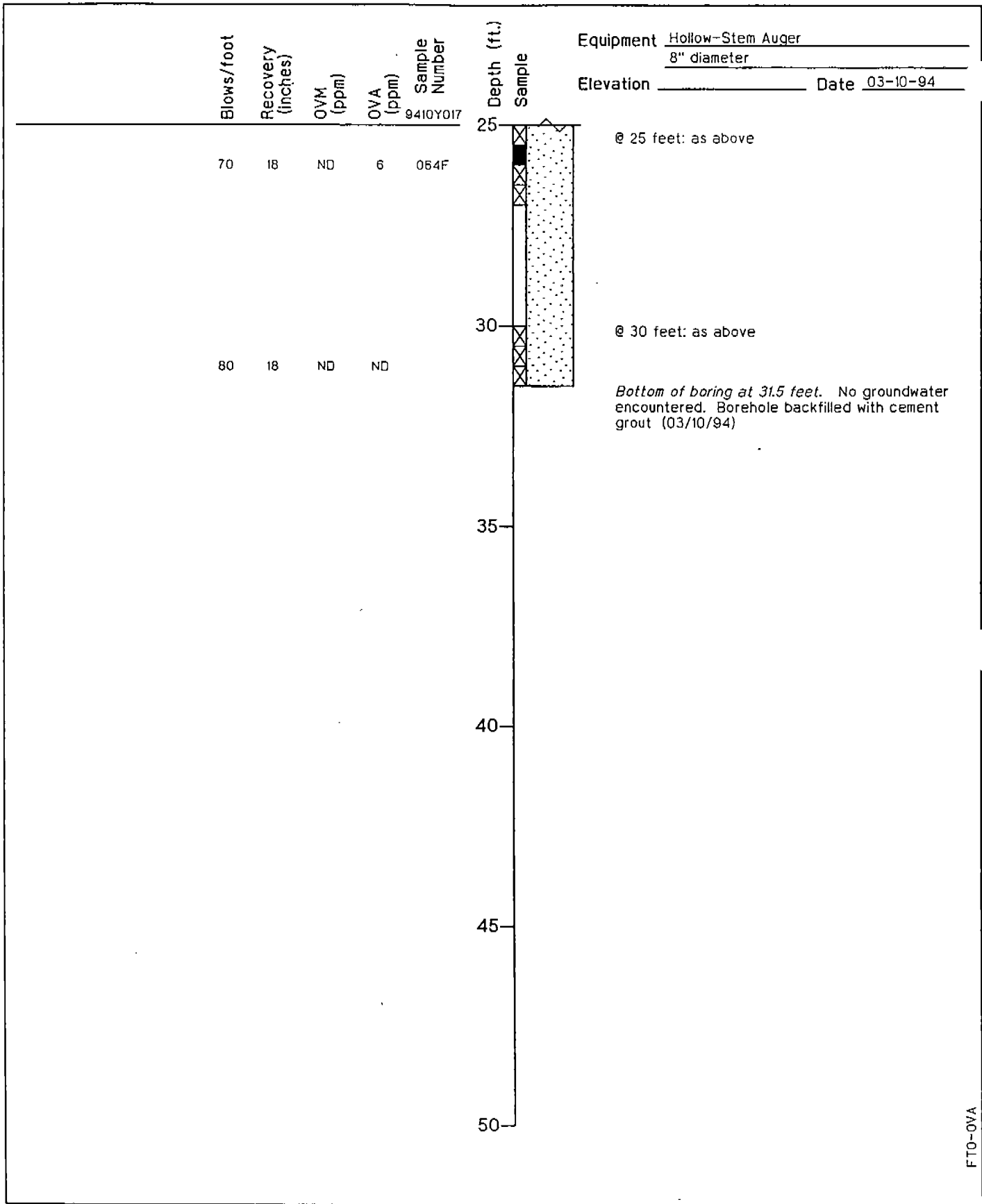

Harding Lawson Associates
Engineering and
Environmental Services

Log of Boring SB-17-10
Site 17 - Disposal Area
Volume II-RI, Basewide RI/FS
Fort Ord, California

PLAT

B41

DRAWN: LRH
JOB NUMBER: 23366 041711

APPROVED: *Rfm*

DATE: 04/94

REVISED DATE

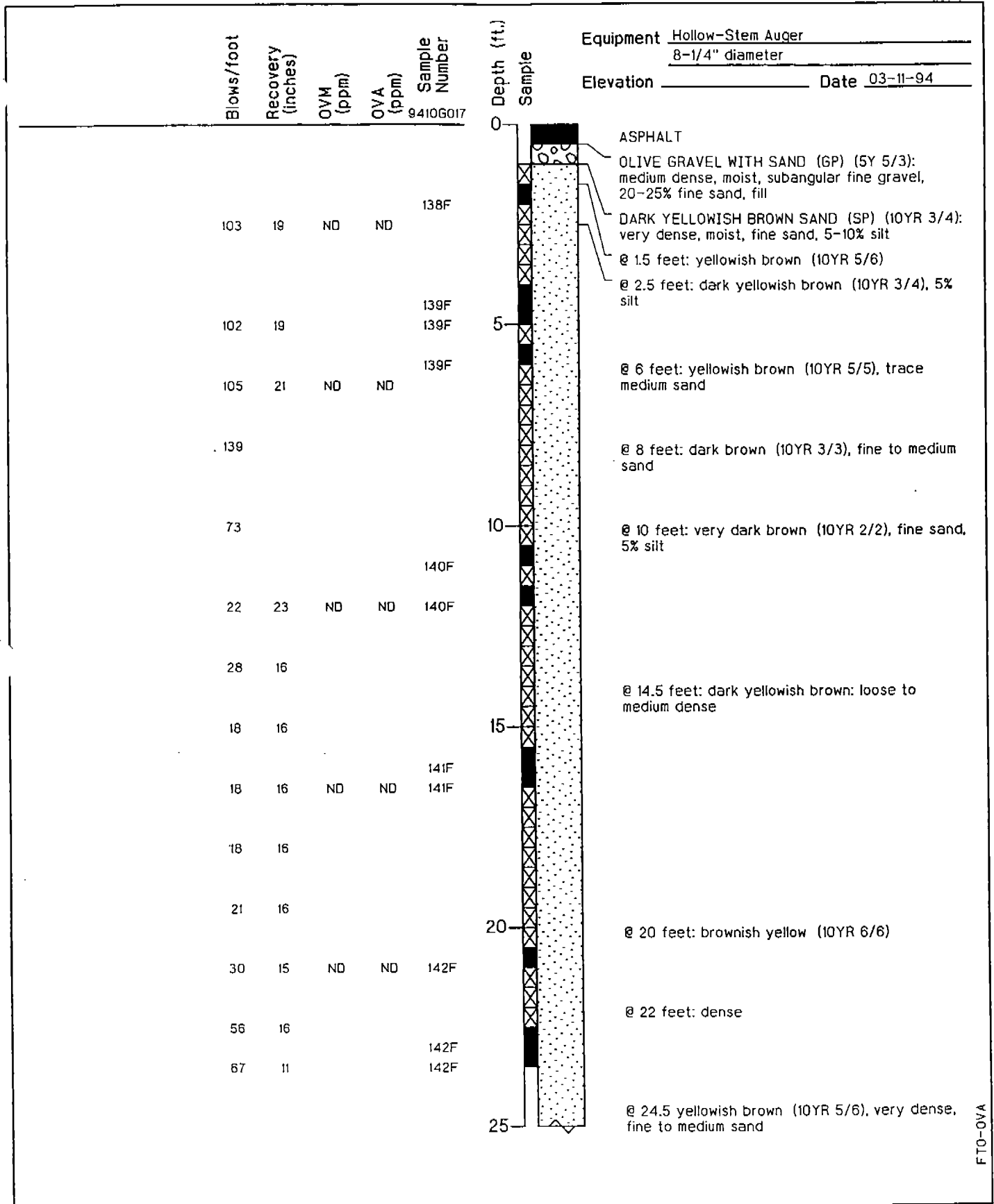

FTO-OVA



Harding Lawson Associates
Engineering and Environmental Services

Log of Boring SB-17-11
Site 17 - Disposal Area
Volume II-RI, Basewide RI/FS
Fort Ord, California

PLATE

B42

DRAWN	JOB NUMBER	APPROVED	DATE	REVISED DATE
LRH	23366 041711	Rfm	04/94	04/29/94

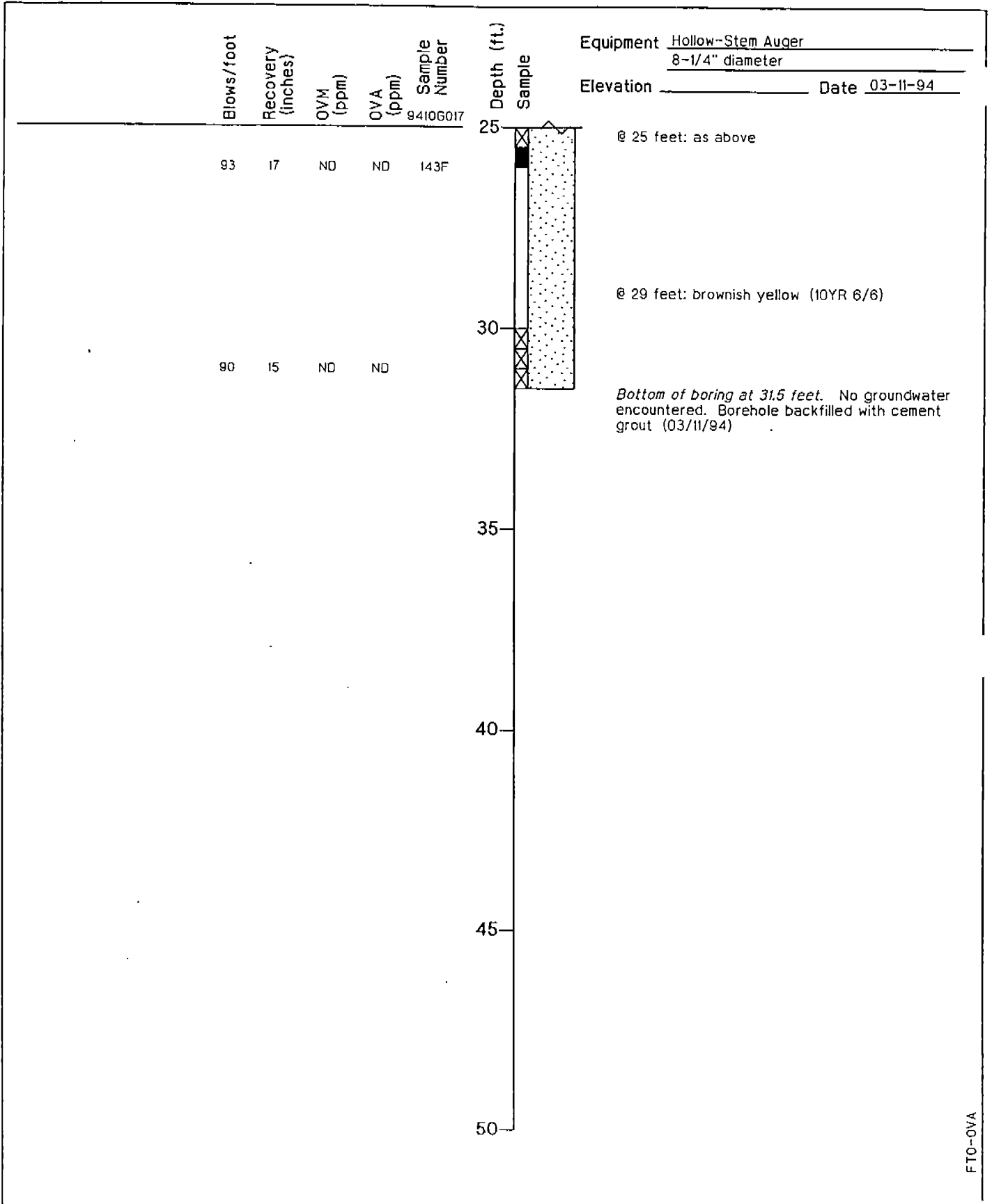

FTO-OVA



Harding Lawson Associates
Engineering and Environmental Services

Log of Boring SB-17-11
Site 17 - Disposal Area
Volume II-RI, Basewide RI/FS
Fort Ord, California

PLA

B42

DRAWN: LRH
JOB NUMBER: 23366 041711

APPROVED: RFM

DATE: 04/94

REVISED DATE: 04/29/94

Blows/foot
Recovery
(inches)
OVM Reading
(ppm)
Sample
Number
9410Y017

Equipment Hollow-Stem Auger
3-1/4" diameter
Elevation _____ Date 03-11-94

Blows/foot	Recovery (inches)	OVM Reading (ppm)	Sample Number
82	20	ND	066F
97	24	ND	
77	24	ND	
15		ND	
5			
9	22	ND	068F
16	18	ND	
24	18	ND	
54	22	ND	
62	16	ND	

Depth (ft.)
Sample

0
ASPHALT
ASPHALT SUBBASE AGGREGATE
BROWNISH YELLOW SAND (SP) (10YR 6/6):
medium dense, moist, medium sand
@ 1.5 feet: dark yellowish brown (10YR 3/6), fine
sand
@ 3 feet: yellowish brown (10YR 5/6), dense
@ 4 feet: dark yellowish brown (10YR 4/6), very
dense, dry
5
@ 8 feet: very dark brown (10YR 2/2), loose
10
@ 10.5 feet: dark yellowish brown (10YR 3/6),
very loose, moist
15
@ 13.5 feet: brownish yellow (10YR 6/8), medium
dense, fine to medium sand
@ 16 feet: dense
20
@ 20 feet: yellowish brown (10YR 5/8)
25

FTO



Harding Lawson Associates
Engineering and
Environmental Services

Log of Boring SB-17-12
Site 17 - Disposal Area
Volume II-RI, Basewide RI/FS
Fort Ord, California

PLATE

B43

DRAWN
LRH

JOB NUMBER
23366 041711

APPROVED
RFM

DATE
04/94

REVISED DATE
04/29/94

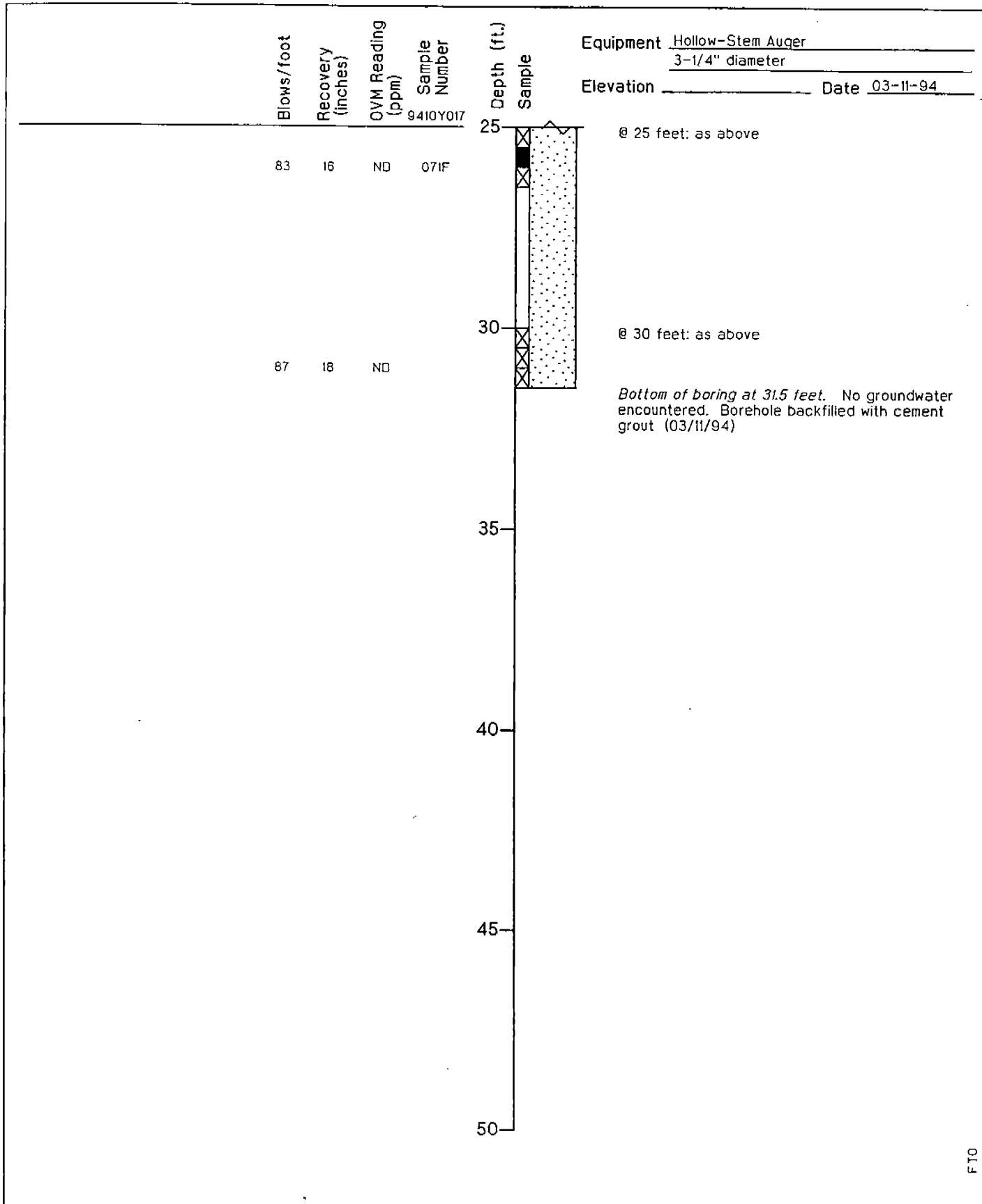

F10



Harding Lawson Associates
Engineering and Environmental Services

Log of Boring SB-17-12
Site 17 - Disposal Area
Volume II-RI, Basewide RI/FS
Fort Ord, California

PLATE

B43

DRAWN: LRH
JOB NUMBER: 23366 041711

APPROVED: RFA

DATE: 04/94

REVISED DATE: 04/29/94

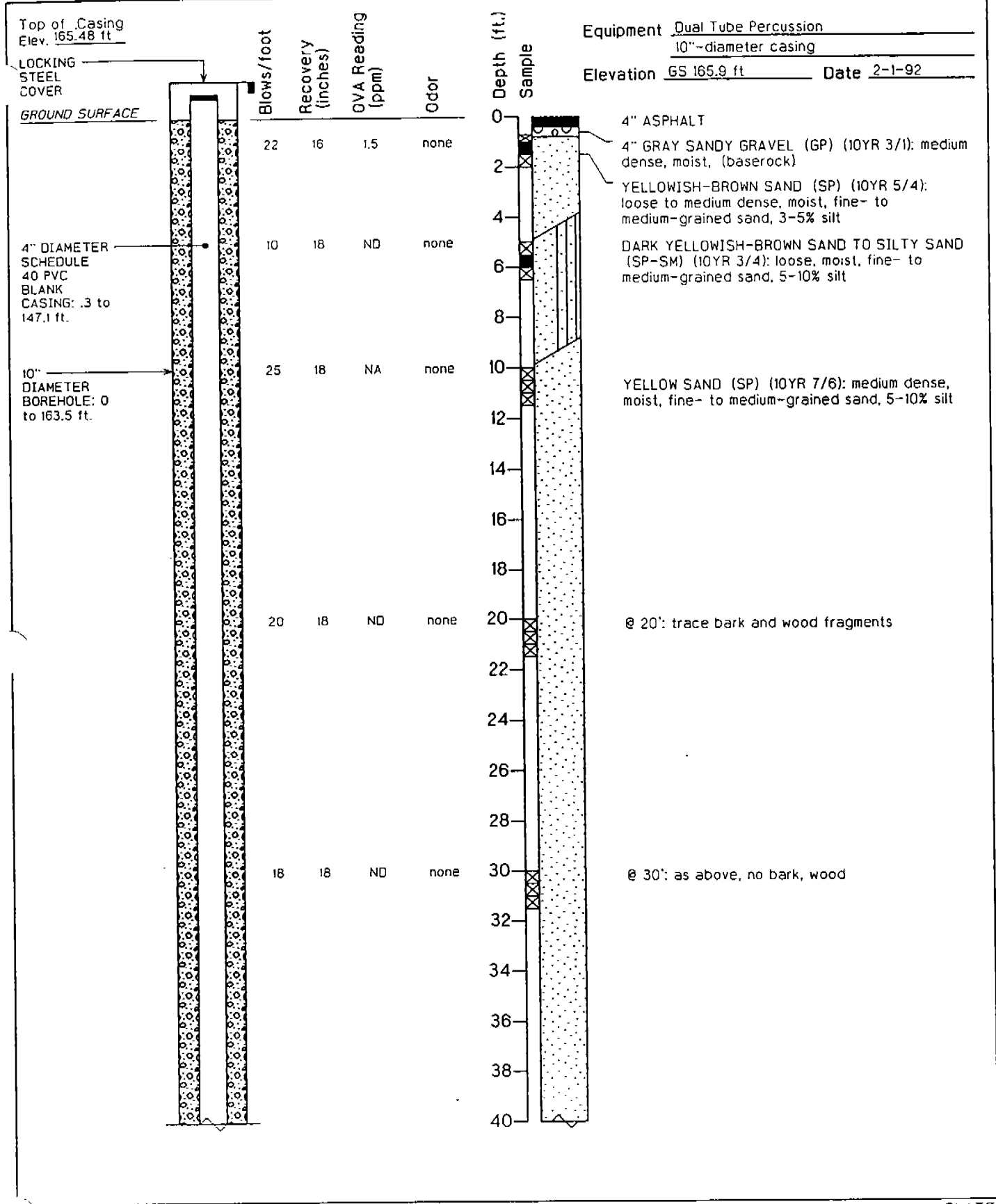

Harding Lawson Associates
 Engineering and Environmental Services

Log of Boring and Well Completion MW-17-01-A
 Site Characterization
 Site 17 - 1400 Block Motor Pool
 Fort Ord, California

PLATE

B44

DRAWN GTG	JOB NUMBER 10776 694	APPROVED <i>[Signature]</i>	DATE 03/93	REVISED DATE
--------------	-------------------------	--------------------------------	---------------	--------------

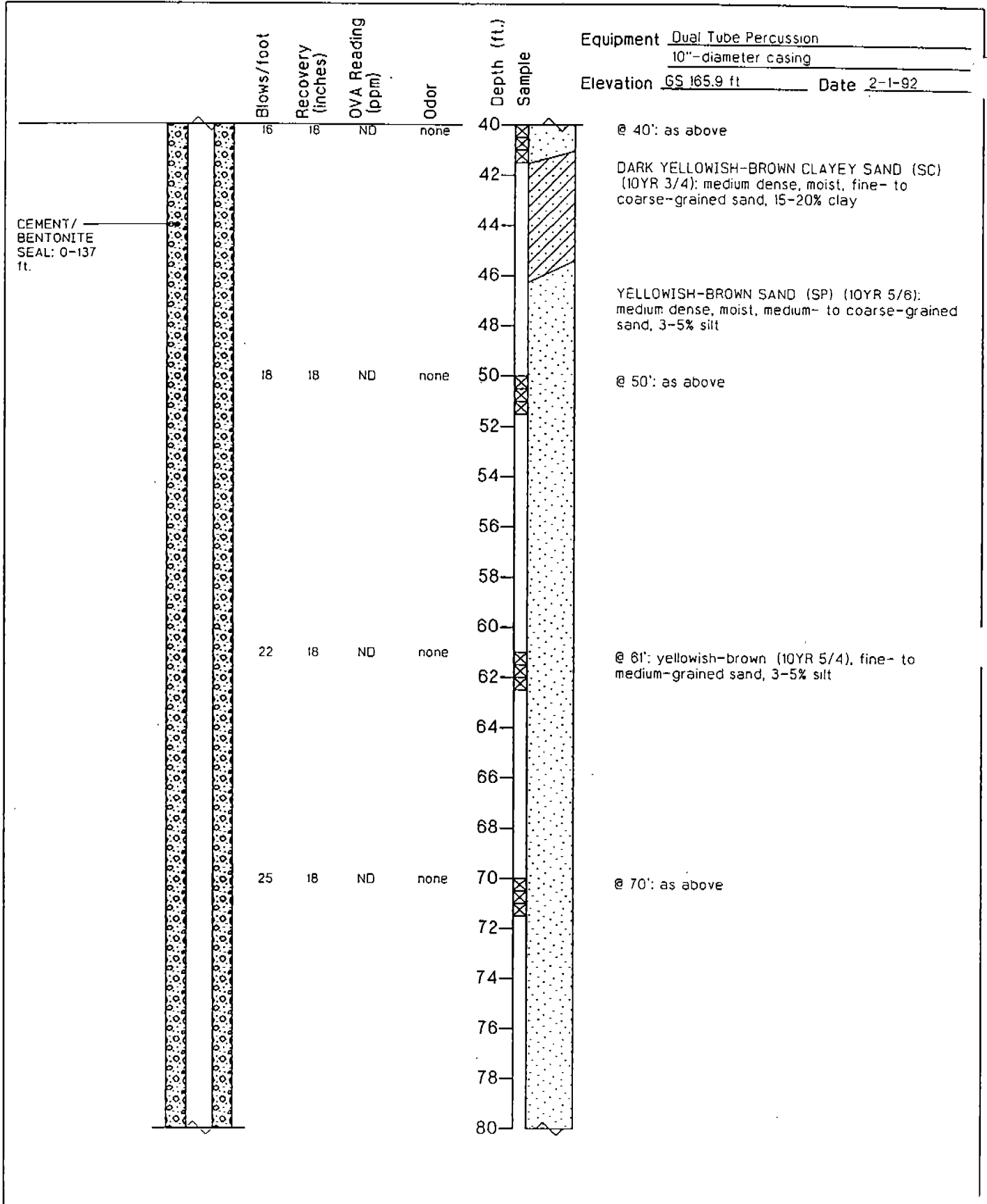

Harding Lawson Associates
 Engineering and Environmental Services

Log of Boring and Well Completion MW-17-01-A
 Site Characterization
 Site 17 - 1400 Block Motor Pool
 Fort Ord, California

PLAT 1

B44

DRAWN GTG	JOB NUMBER 10776 694	APPROVED <i>[Signature]</i>	DATE 03/93	REVISED DATE
--------------	-------------------------	--------------------------------	---------------	--------------

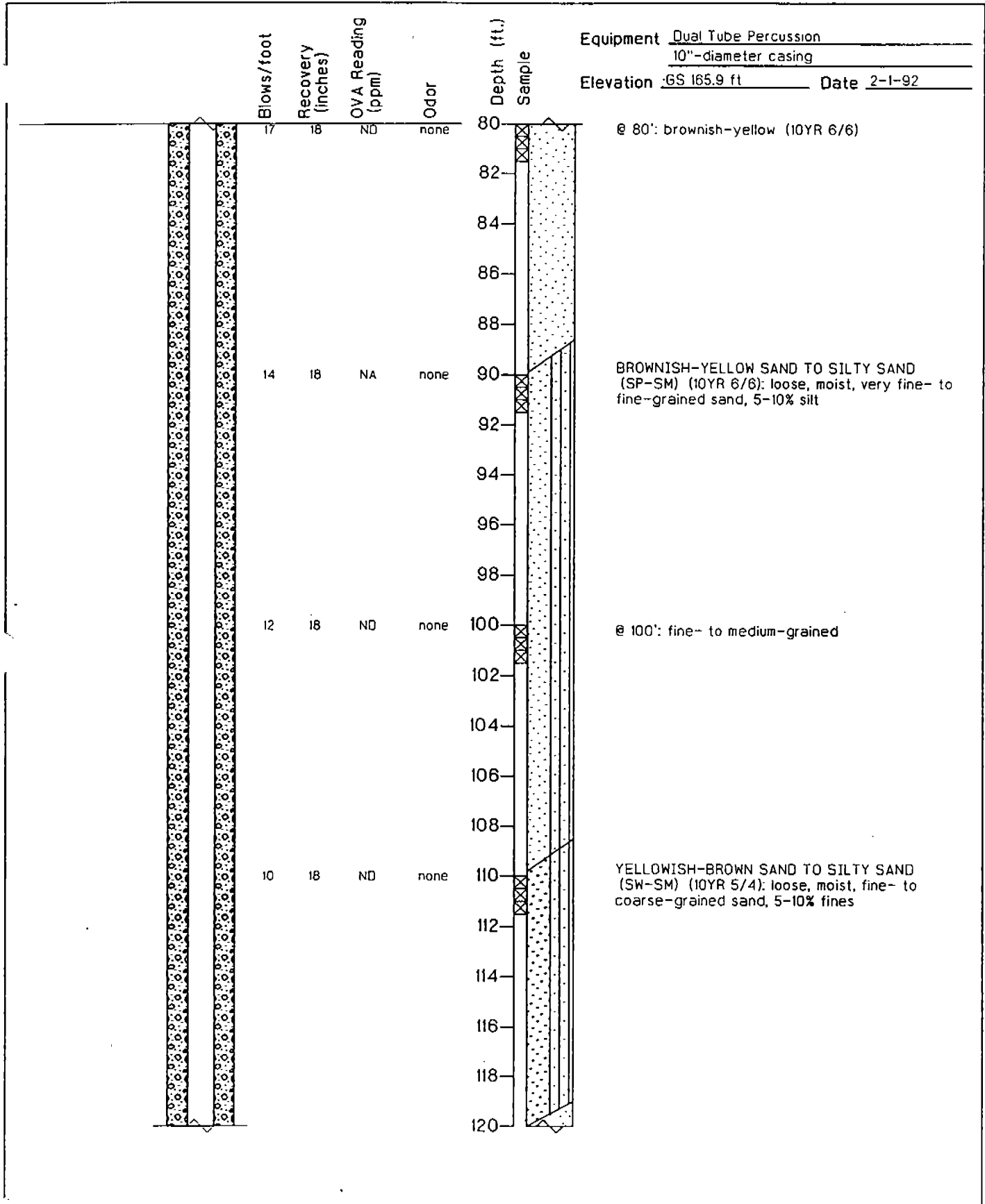

Harding Lawson Associates
Engineering and Environmental Services

Log of Boring and Well Completion MW-17-01-A
Site Characterization
Site 17 - 1400 Block Motor Pool
Fort Ord, California

PLATE

B44

DRAWN GTG	JOB NUMBER 10776 694	APPROVED <i>ES</i>	DATE 03/93	REVISED DATE
--------------	-------------------------	-----------------------	---------------	--------------

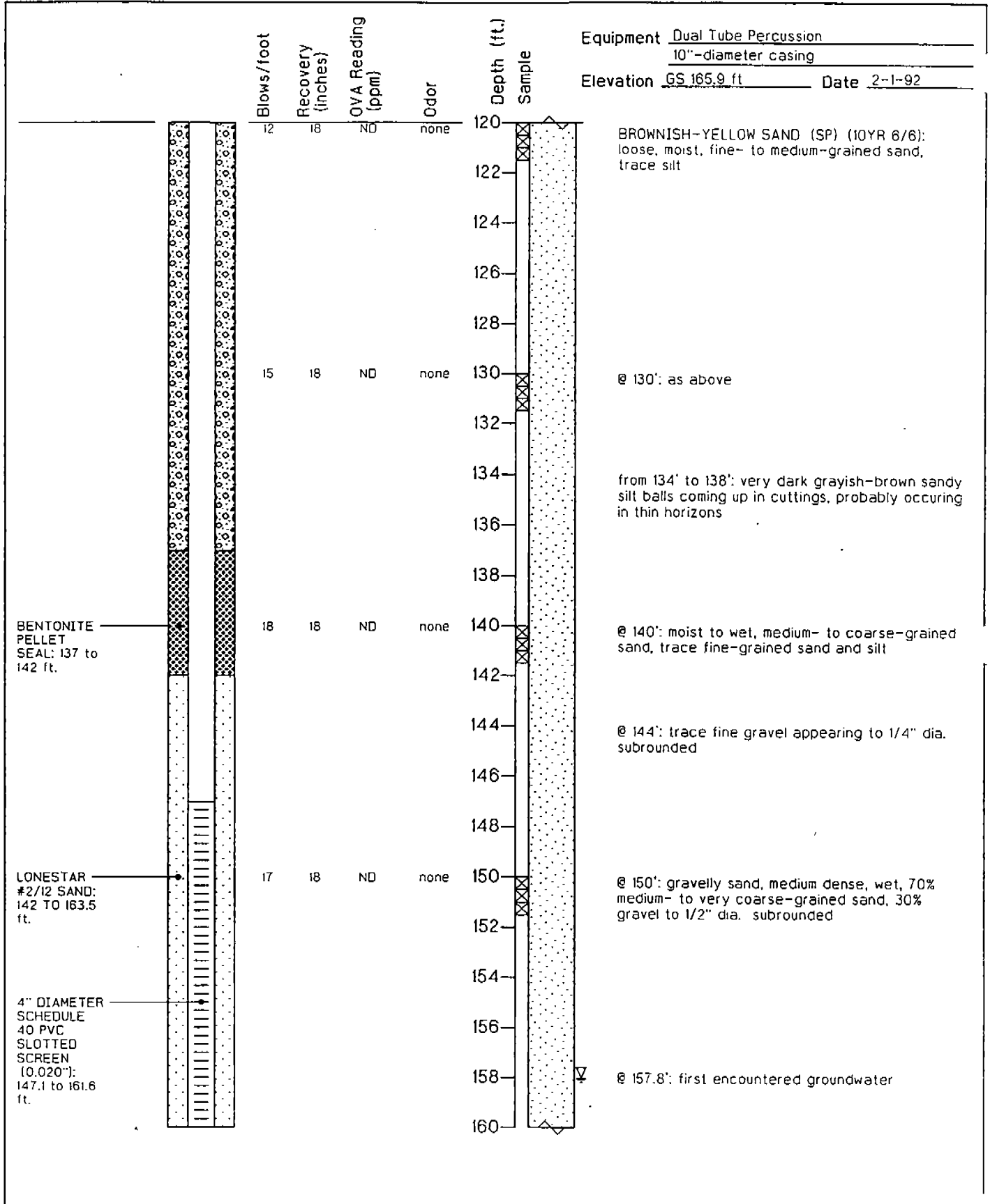

Harding Lawson Associates
Engineering and Environmental Services

Log of Boring and Well Completion MW-17-01-A
Site Characterization
Site 17 - 1400 Block Motor Pool
Fort Ord, California

PLATE

B44

DRAWN GTG	JOB NUMBER 10776 694	APPROVED <i>[Signature]</i>	DATE 03/93	REVISED DATE
--------------	-------------------------	--------------------------------	---------------	--------------

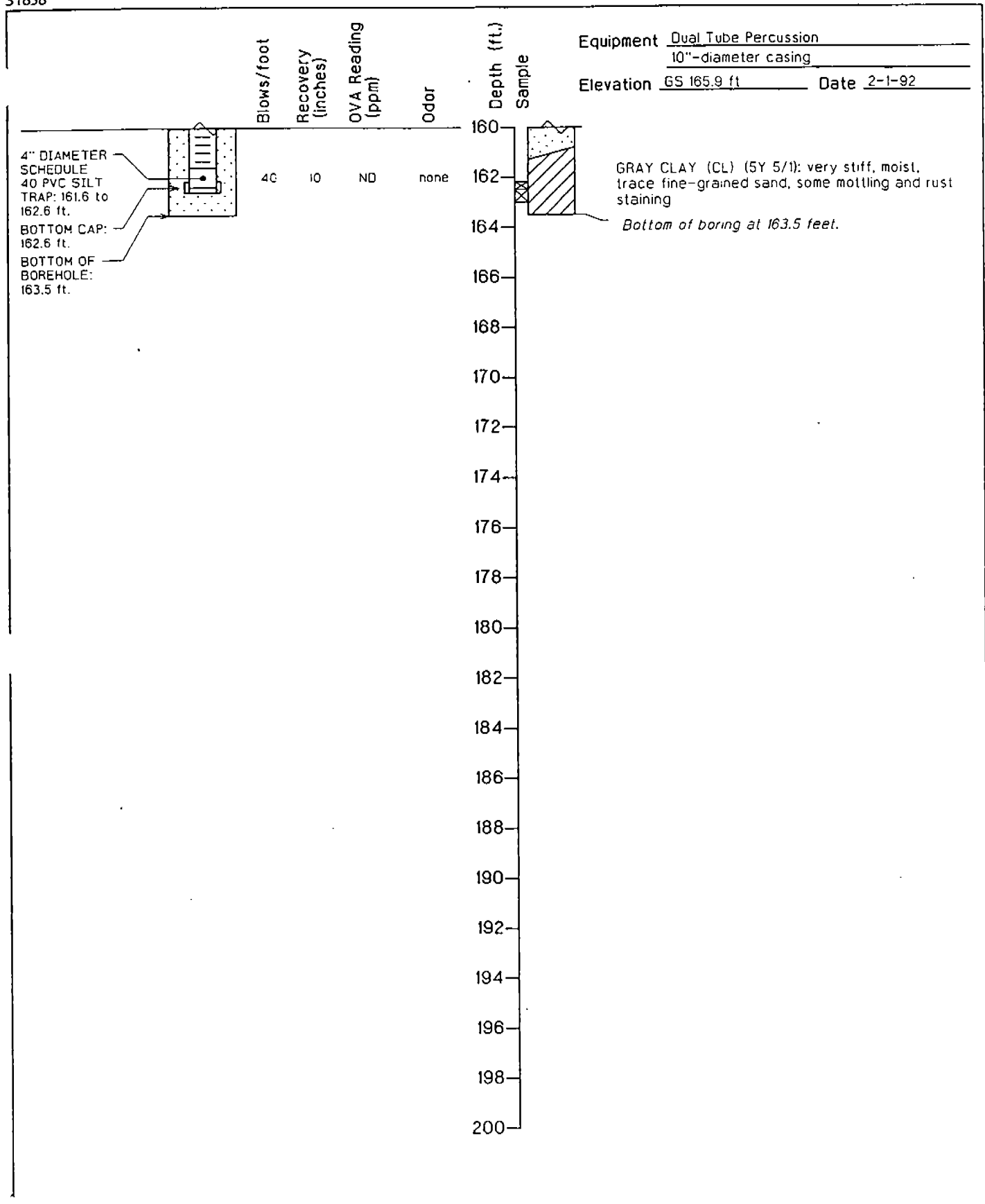

Harding Lawson Associates
 Engineering and Environmental Services

Log of Boring and Well Completion MW-17-01-A
 Site Characterization
 Site 17 - 1400 Block Motor Pool
 Fort Ord, California

PLATE

B44

DRAWN	JOB NUMBER	APPROVED	DATE	REVISED DATE
GTG	10776 694		03/93	

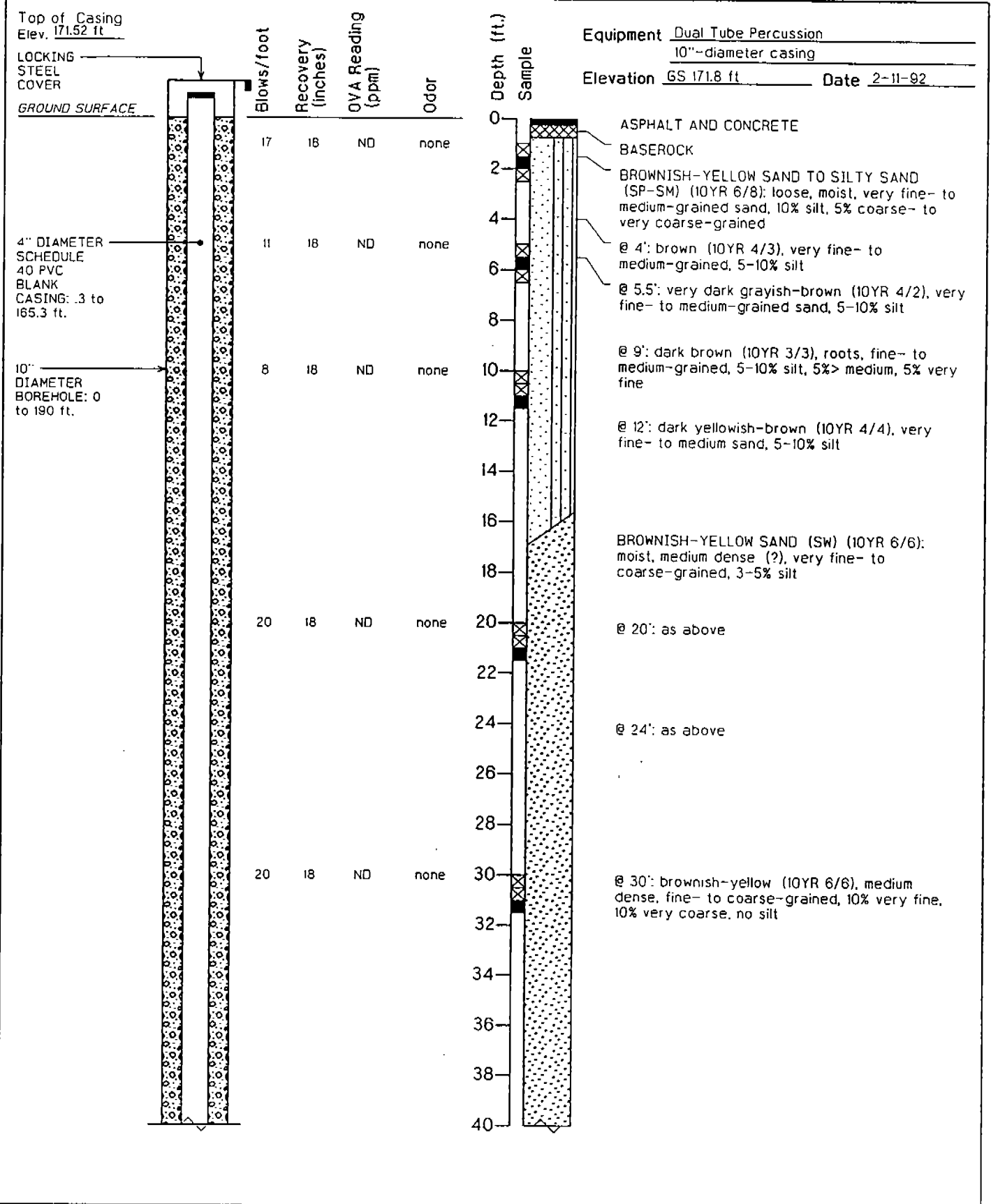

Harding Lawson Associates
 Engineering and Environmental Services

Log of Boring and Well Completion MW-17-02-180
 Site Characterization
 Site 17 - 1400 Block Motor Pool
 Fort Ord, California

PLATE

B45

DRAWN GTG	JOB NUMBER 10776 694	APPROVED <i>gs</i>	DATE 03/93	REVISED DATE
--------------	-------------------------	-----------------------	---------------	--------------

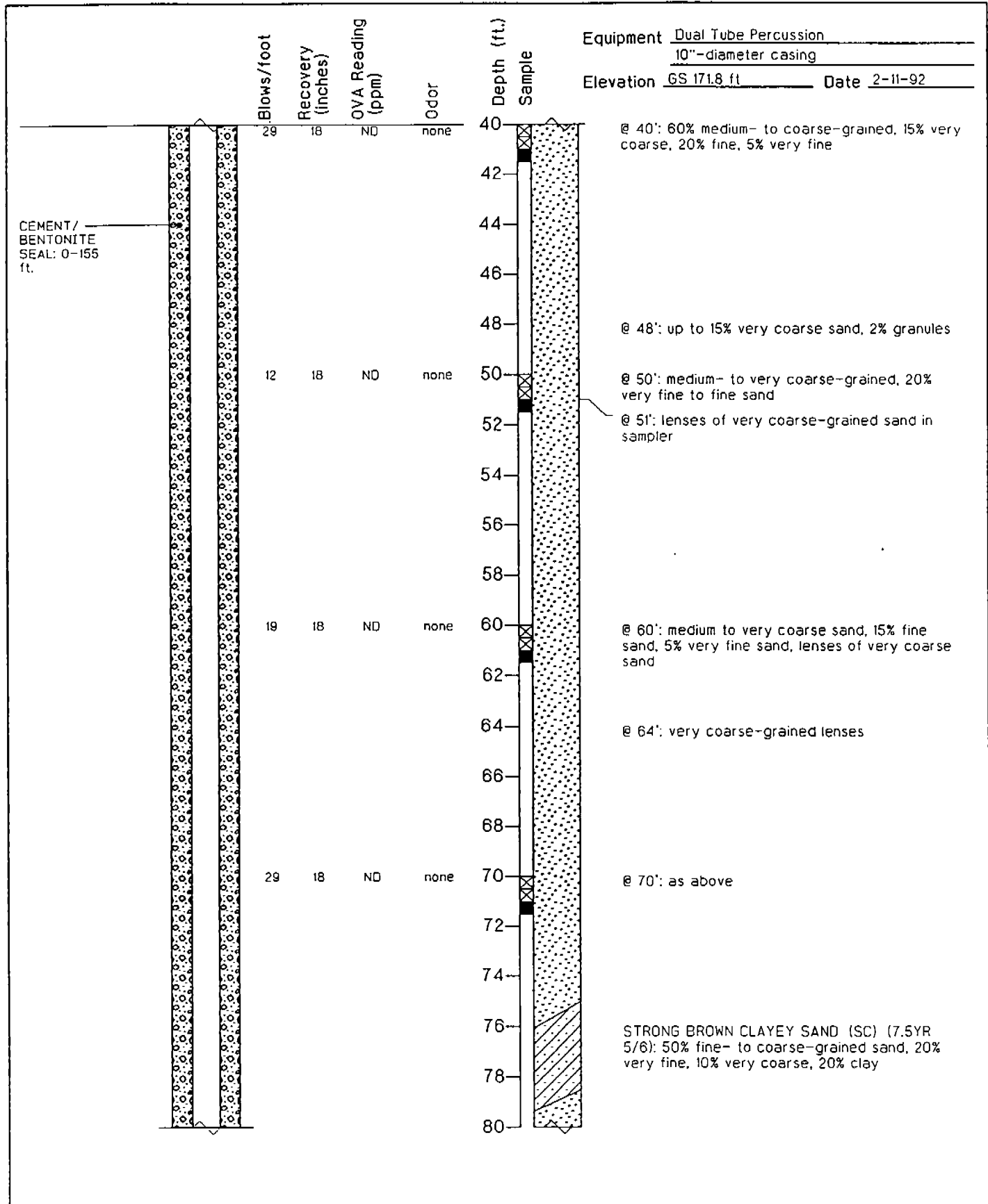

Harding Lawson Associates
Engineering and
Environmental Services

Log of Boring and Well Completion MW-17-02-180
Site Characterization
Site 17 - 1400 Block Motor Pool
Fort Ord, California

PLATE

B45

DRAWN GTG	JOB NUMBER 10776 694	APPROVED <i>EG</i>	DATE 03/93	REVISED DATE
--------------	-------------------------	-----------------------	---------------	--------------

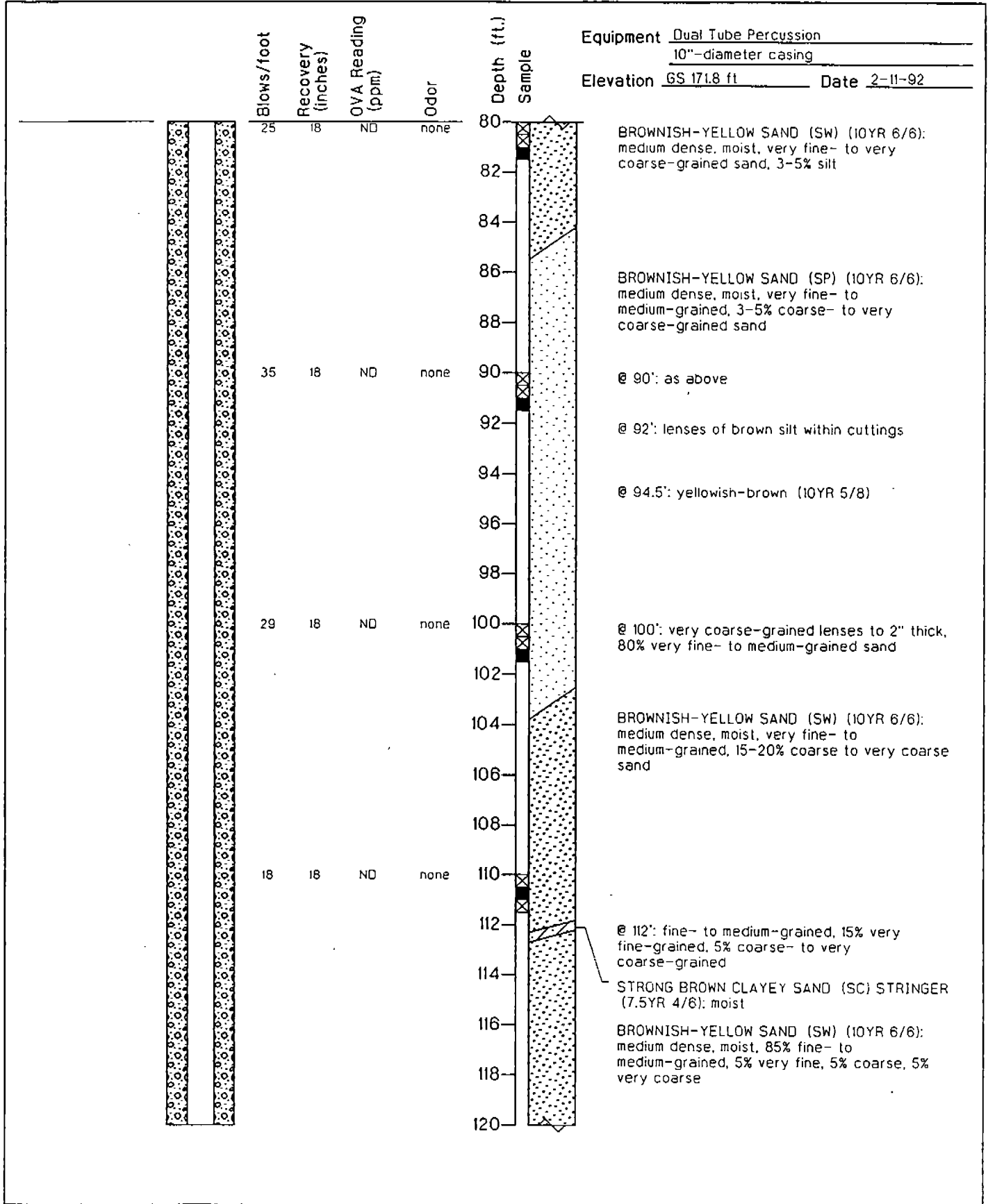

Harding Lawson Associates
 Engineering and Environmental Services

Log of Boring and Well Completion MW-17-02-180
 Site Characterization
 Site 17 - 1400 Block Motor Pool
 Fort Ord, California

PLATE

B45

DRAWN GTG	JOB NUMBER 10776 694	APPROVED <i>[Signature]</i>	DATE 03/93	REVISED DATE
--------------	-------------------------	--------------------------------	---------------	--------------

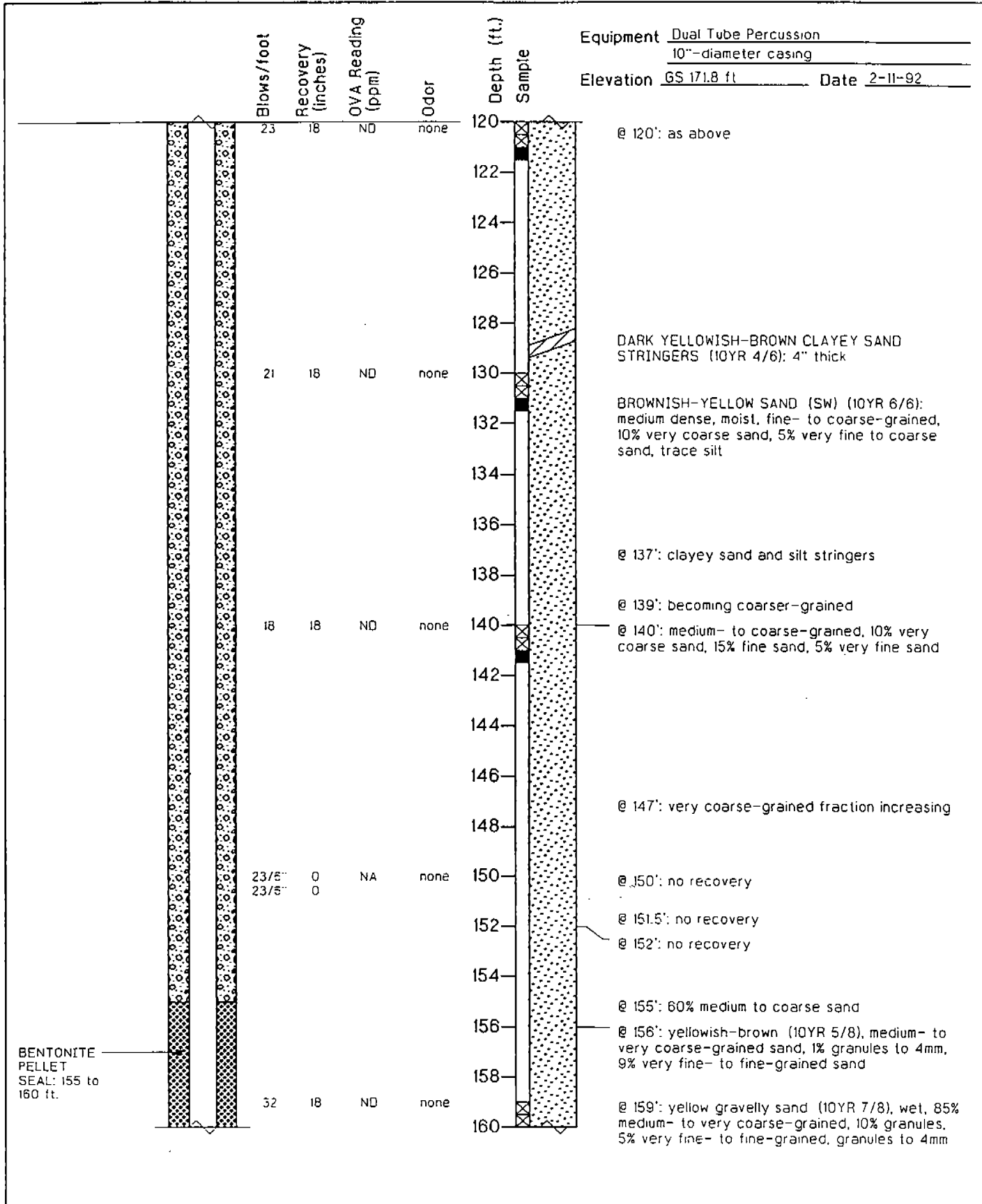

Harding Lawson Associates
 Engineering and Environmental Services

Log of Boring and Well Completion MW-17-02-180
 Site Characterization
 Site 17 - 1400 Block Motor Pool
 Fort Ord, California

PLATE

B45

DRAWN	JOB NUMBER	APPROVED	DATE	REVISED DATE
GTG	10776 694	<i>[Signature]</i>	03/93	

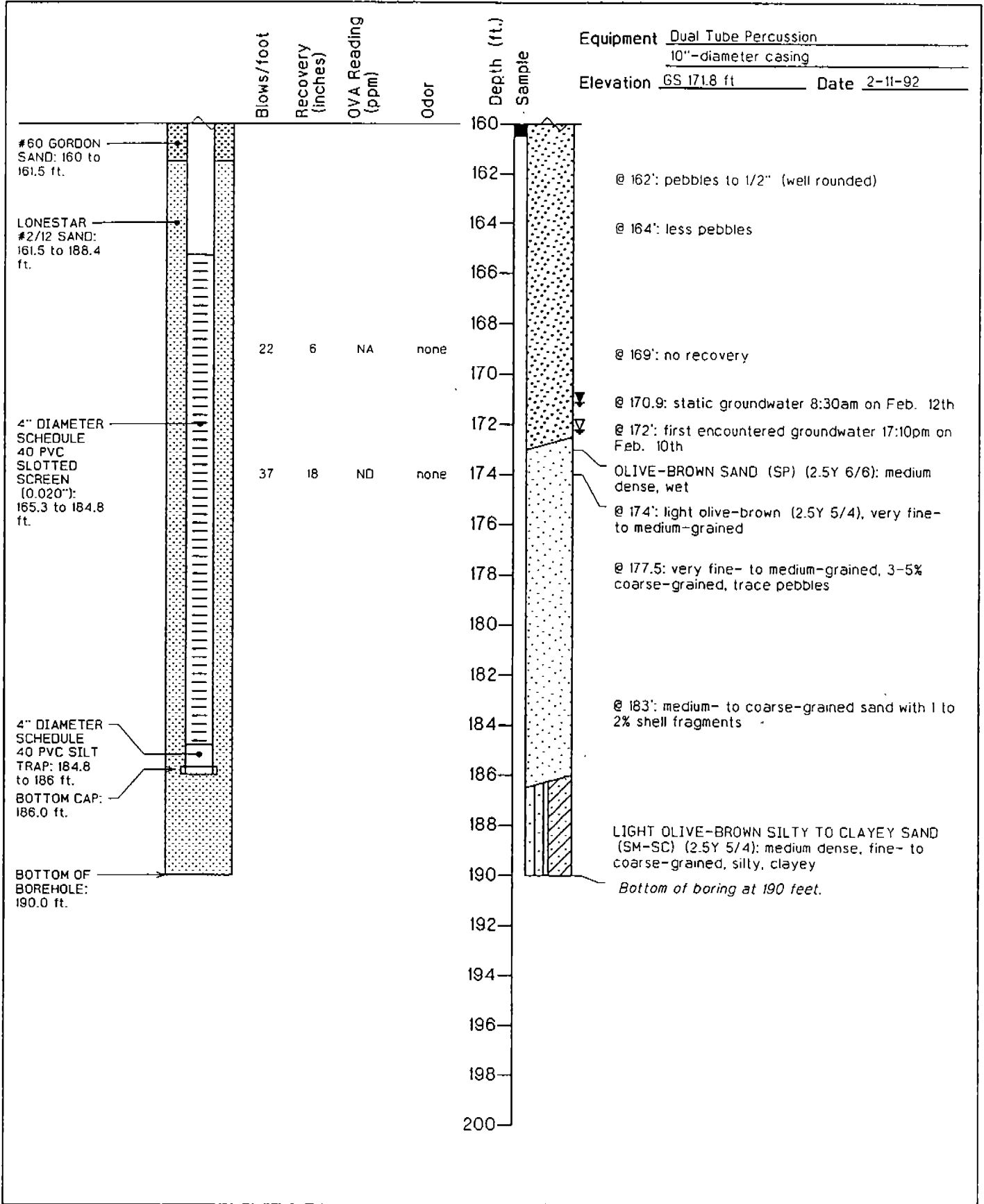

Harding Lawson Associates
 Engineering and Environmental Services

Log of Boring and Well Completion MW-17-02-180
 Site Characterization
 Site 17 - 1400 Block Motor Pool
 Fort Ord, California

PLATE

B45

DRAWN
GTG

JOB NUMBER
10776 694

APPROVED
[Signature]

DATE
03/93

REVISED DATE

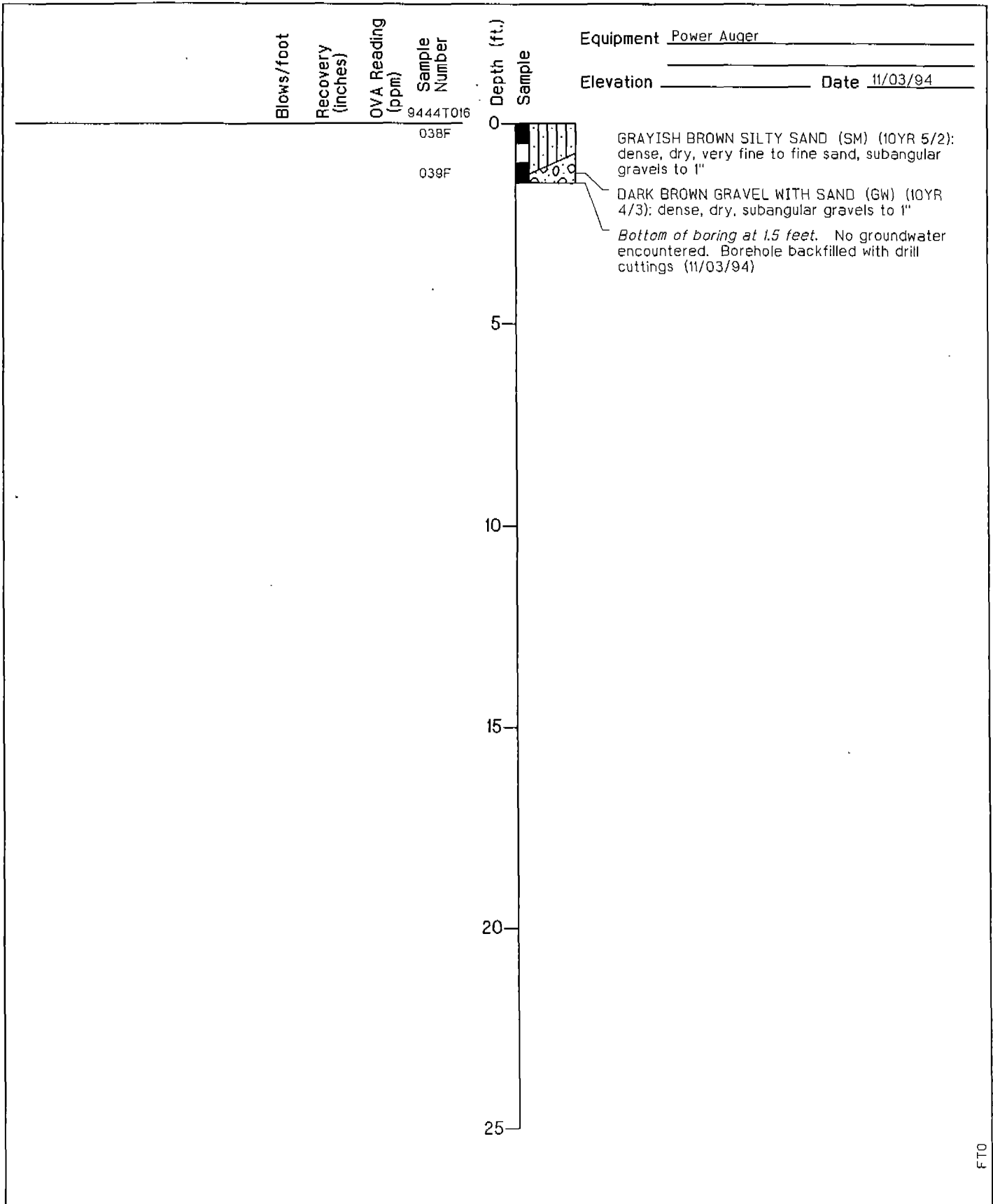

FTO



Harding Lawson Associates
Engineering and Environmental Services

Log of Boring SB-16-29
Site 16 - DOL Maintenance Yard
Volume II-RI, Basewide RI/FS
Fort Ord, California

PLATE

B46

DRAWN	JOB NUMBER	APPROVED	DATE	REVISED DATE
CEG	23366 041721	RFM	11/94	

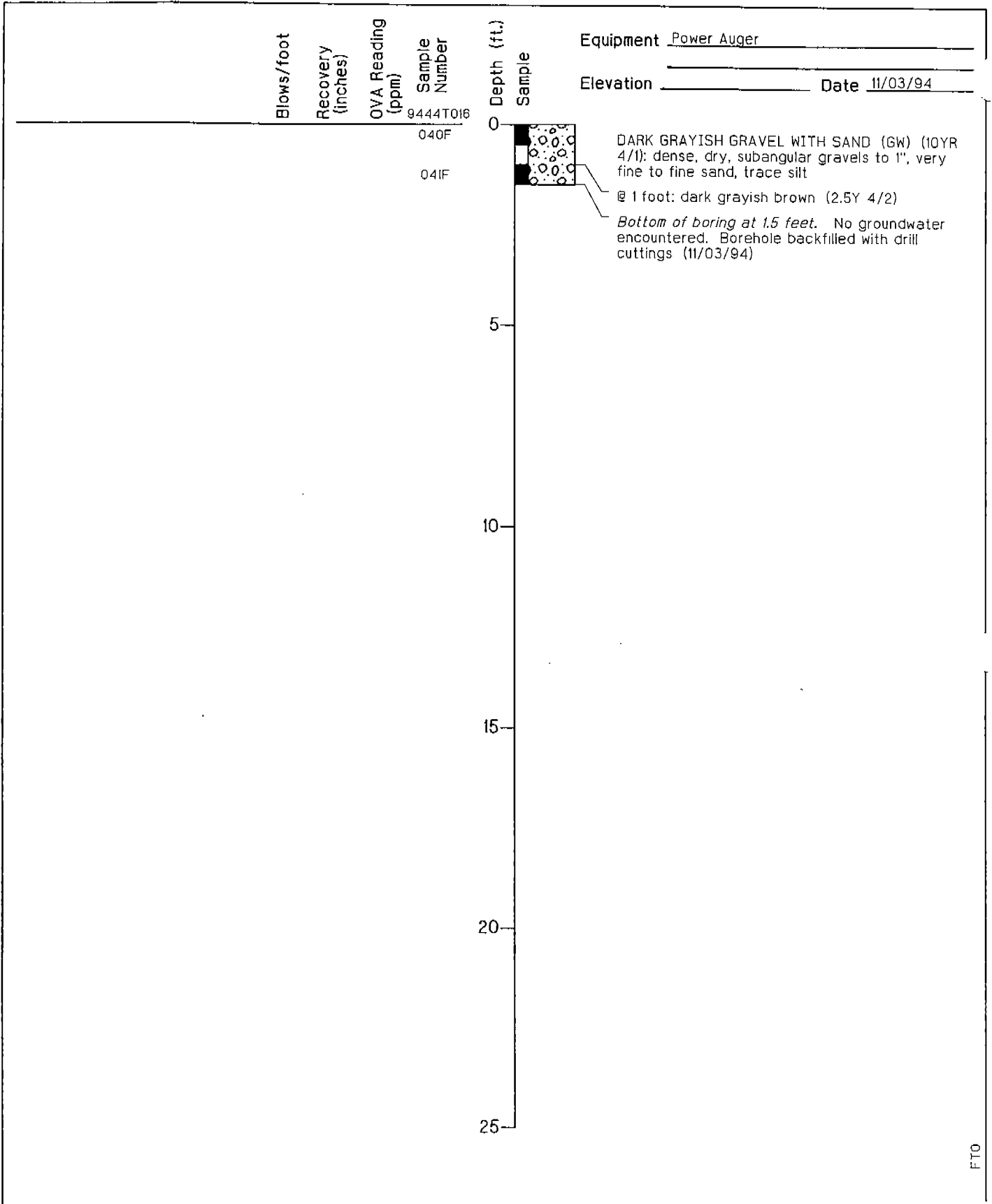

FTO



Harding Lawson Associates
 Engineering and
 Environmental Services

Log of Boring SB-16-30
 Site 16 - DOL Maintenance Yard
 Volume II-RI, Basewide RI/FS
 Fort Ord, California

PLAT

B47

DRAWN	JOB NUMBER	APPROVED	DATE	REVISED DATE
CEG	23366 041721	RFM	11/94	

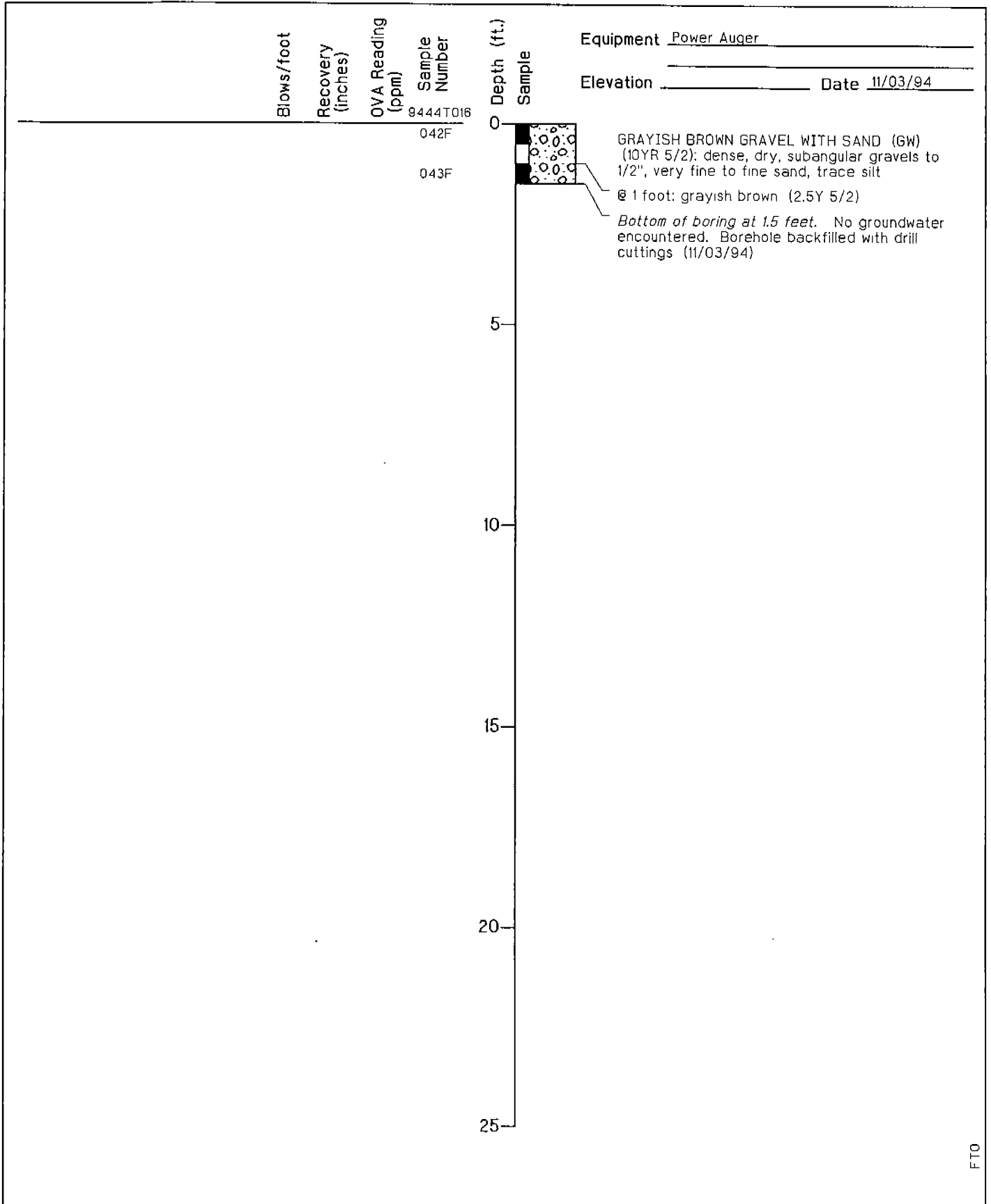

FTO



Harding Lawson Associates
 Engineering and Environmental Services

Log of Boring SB-16-31
 Site 16 - DOL Maintenance Yard
 Volume II-RI, Basewide RI/FS
 Fort Ord, California

PLATE

B48

DRAWN: CEG
 JOB NUMBER: 23366 041721

APPROVED: *AFM*

DATE: 11/94

REVISED DATE

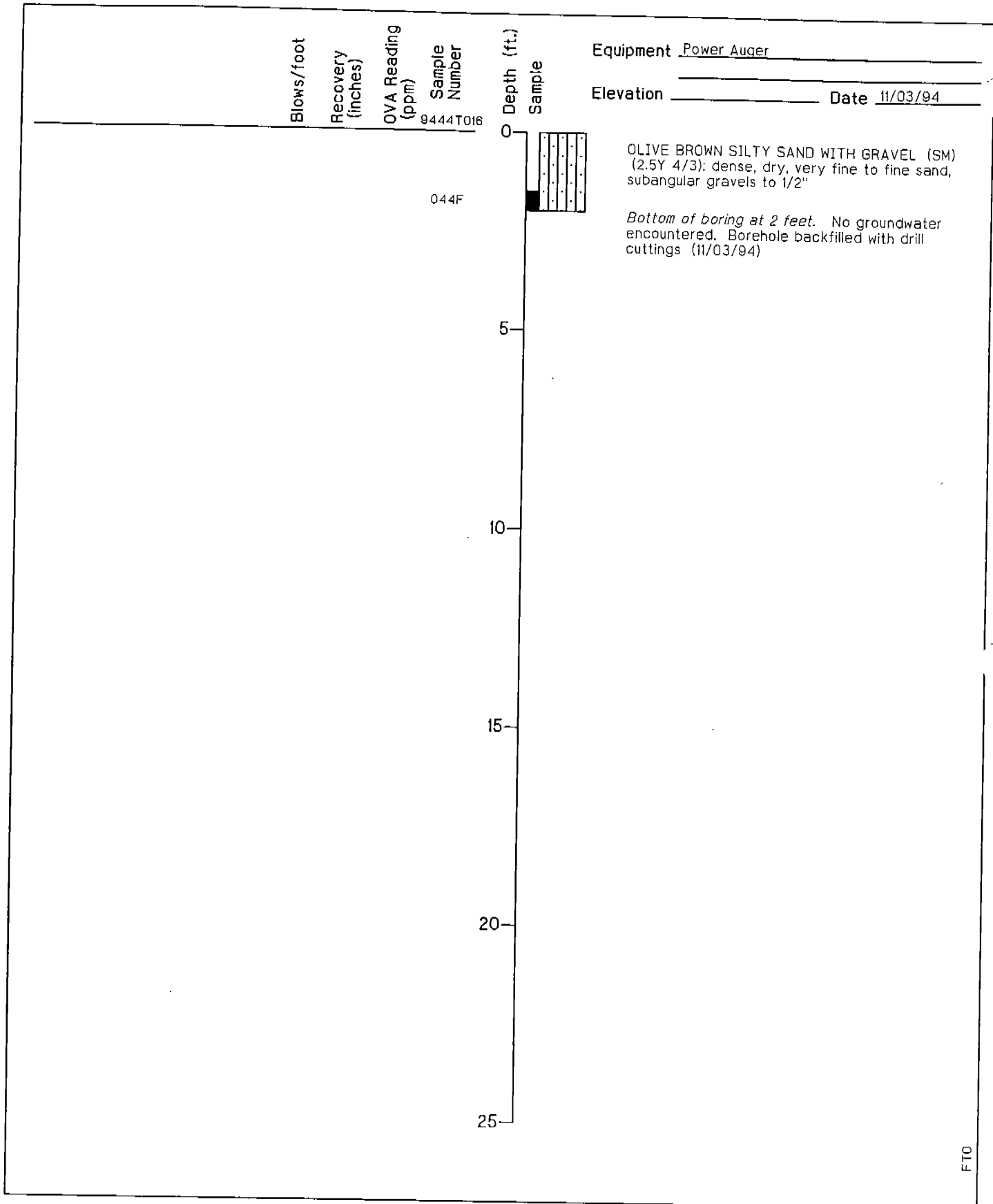

FTO



Harding Lawson Associates
Engineering and Environmental Services

Log of Boring SB-16-32
Site 16 - DOL Maintenance Yard
Volume II-RI, Basewide RI/FS
Fort Ord, California

PLATE

B49

DRAWN CEG	JOB NUMBER 23366 041721	APPROVED <i>RFM</i>	DATE 11/94	REVISED DATE
--------------	----------------------------	------------------------	---------------	--------------

16/17D
WEST

16/17D'
EAST

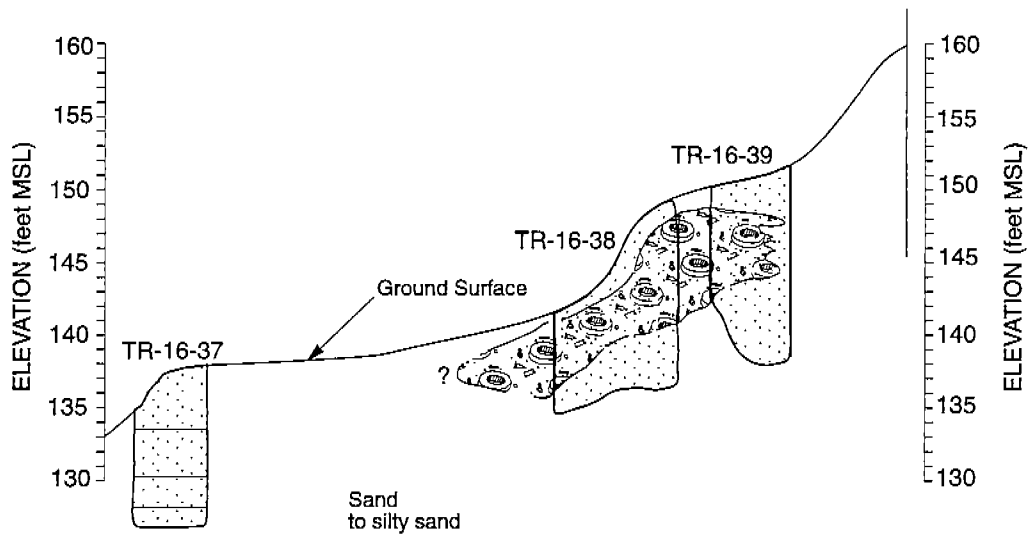

Vertical Scale: 1" = 8'
Horizontal Scale: 1" = 40'
Vertical Exaggeration 5:1

EXPLANATION



Extent of subsurface debris; dashed where inferred and queried where uncertain

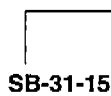

Type designation
SB - Soil Boring
TR - Test Pit

SB-31-15

Soil Boring or Test Pit number

Site number

Notes

1. See Plate A1 in Appendix A for key to patterns
2. Location of cross section shown on Plate 3



Harding Lawson Associates
Engineering and
Environmental Services

Geologic Cross Section 16/17D - 16/17D'
Site 16 - Pete's Pond Extension
Volume II - RI, Basewide RI/FS
Fort Ord, California

PLATE

18

DRAWN
AGc

JOB NUMBER
23366 041721

APPROVED
REM

DATE
12/94

REVISED DATE

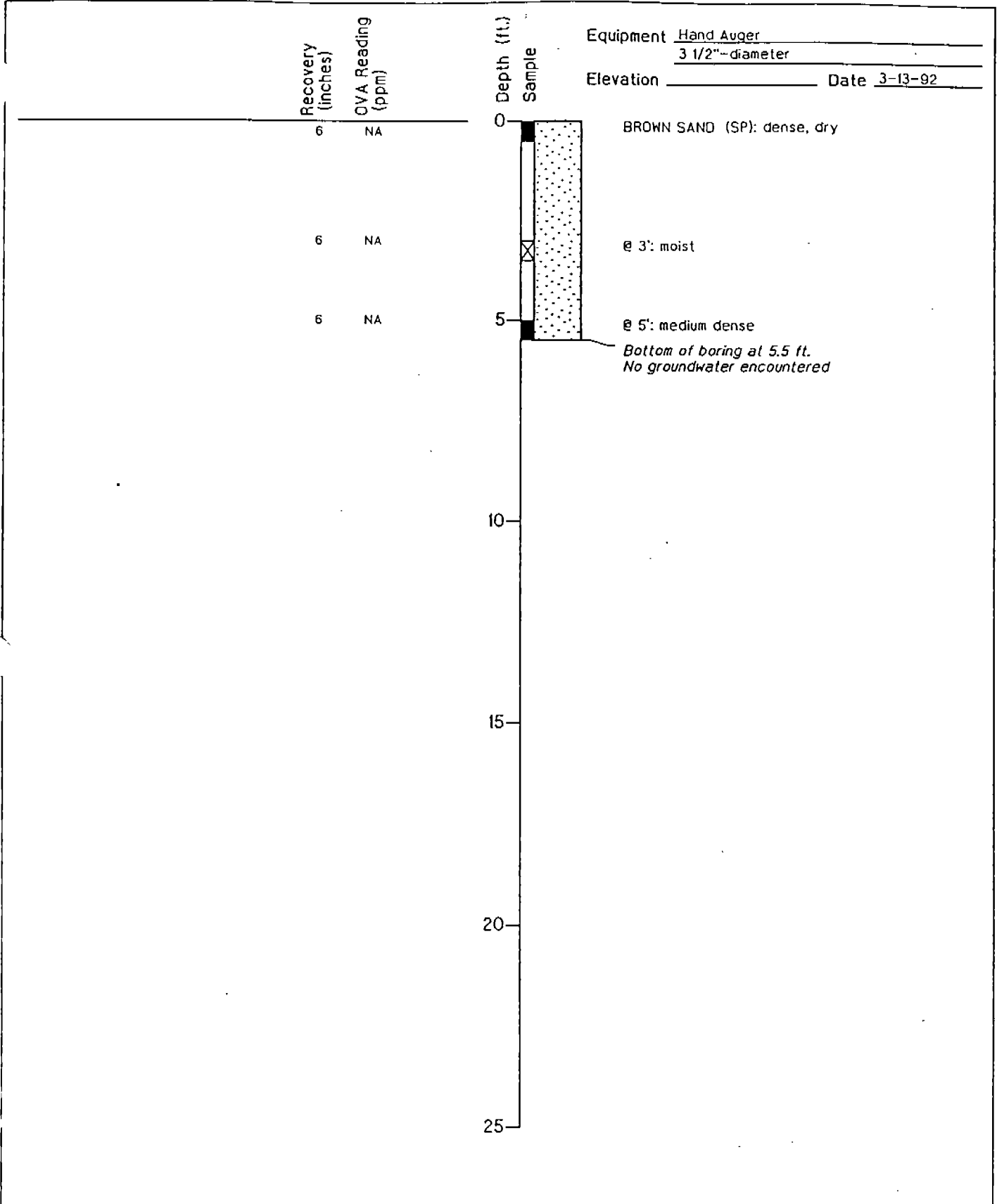

Harding Lawson Associates
 Engineering and
 Environmental Services

Log of Boring OF-16-03-02
 Basewide Surface Water Investigation
 Remedial Investigation
 Fort Ord, California

PLATE

A 18

DRAWN	JOB NUMBER	APPROVED	DATE	REVISED DATE
CEG	07579,534.02	JDM	06/92	

Recovery (inches)
OVA Reading (ppm)

0 NA

Depth (ft.)
Sample

Equipment Hand Auger
3 1/2"-diameter
Elevation _____ Date 3-13-92

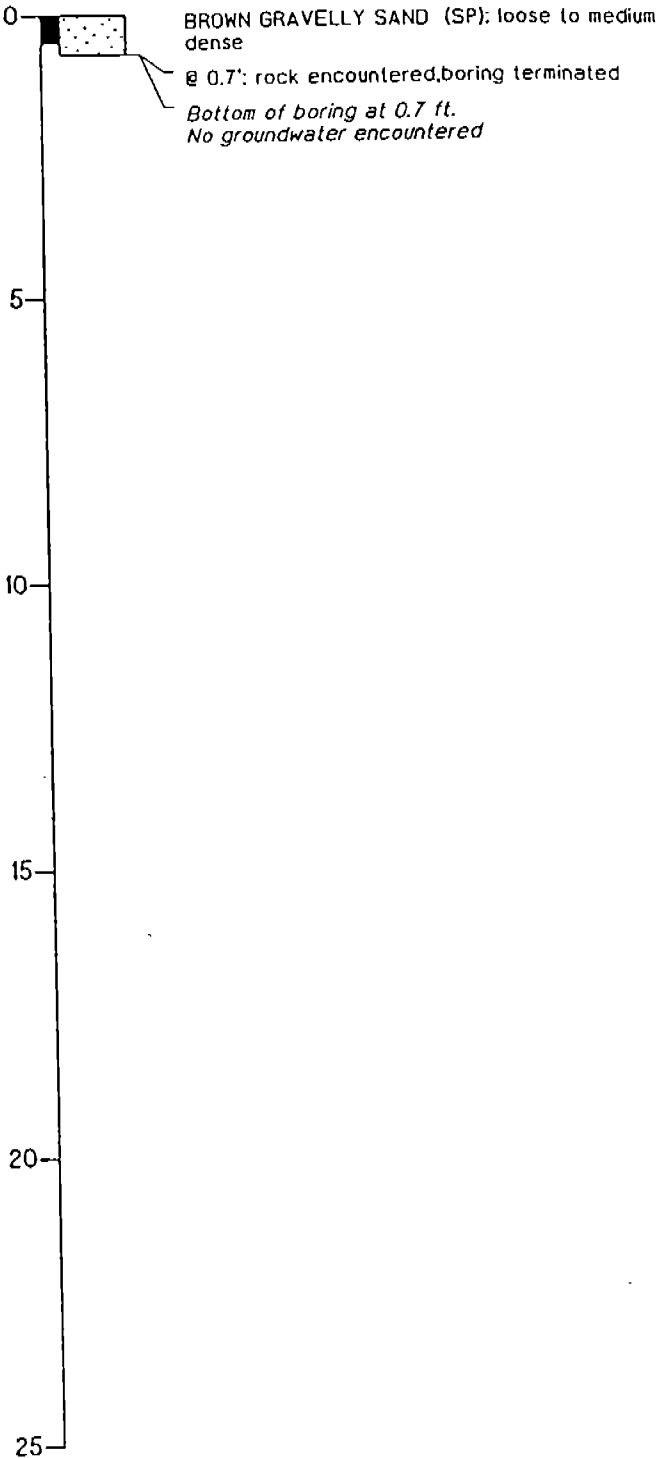

Harding Lawson Associates
Engineering and
Environmental Services

Log of Boring OF-16-04-02
Basewide Surface Water Investigation
Remedial Investigation
Fort Ord, California

PLATE

A20

DRAWN CEG JOB NUMBER 07579,534.02

APPROVED JDM

DATE 06/92

REVISED DATE

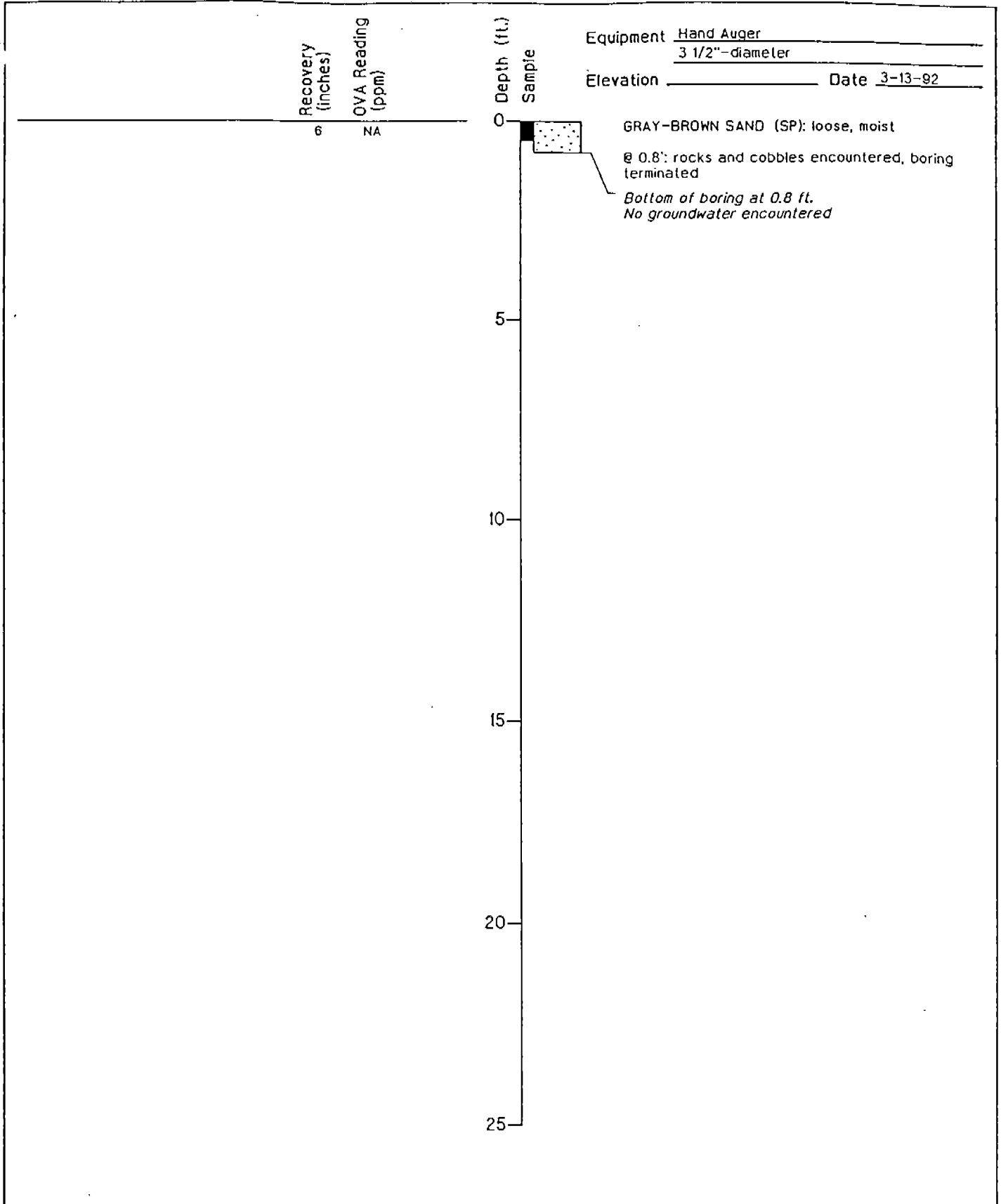

Harding Lawson Associates
 Engineering and
 Environmental Services

Log of Boring **OF-16-05-01**
 Basewide Surface Water Investigation
 Remedial Investigation
 Fort Ord, California

PLATE

A21

DRAWN: CEG JOB NUMBER: 07579,534.02

APPROVED: *Jon*

DATE: 06/92

REVISED DATE

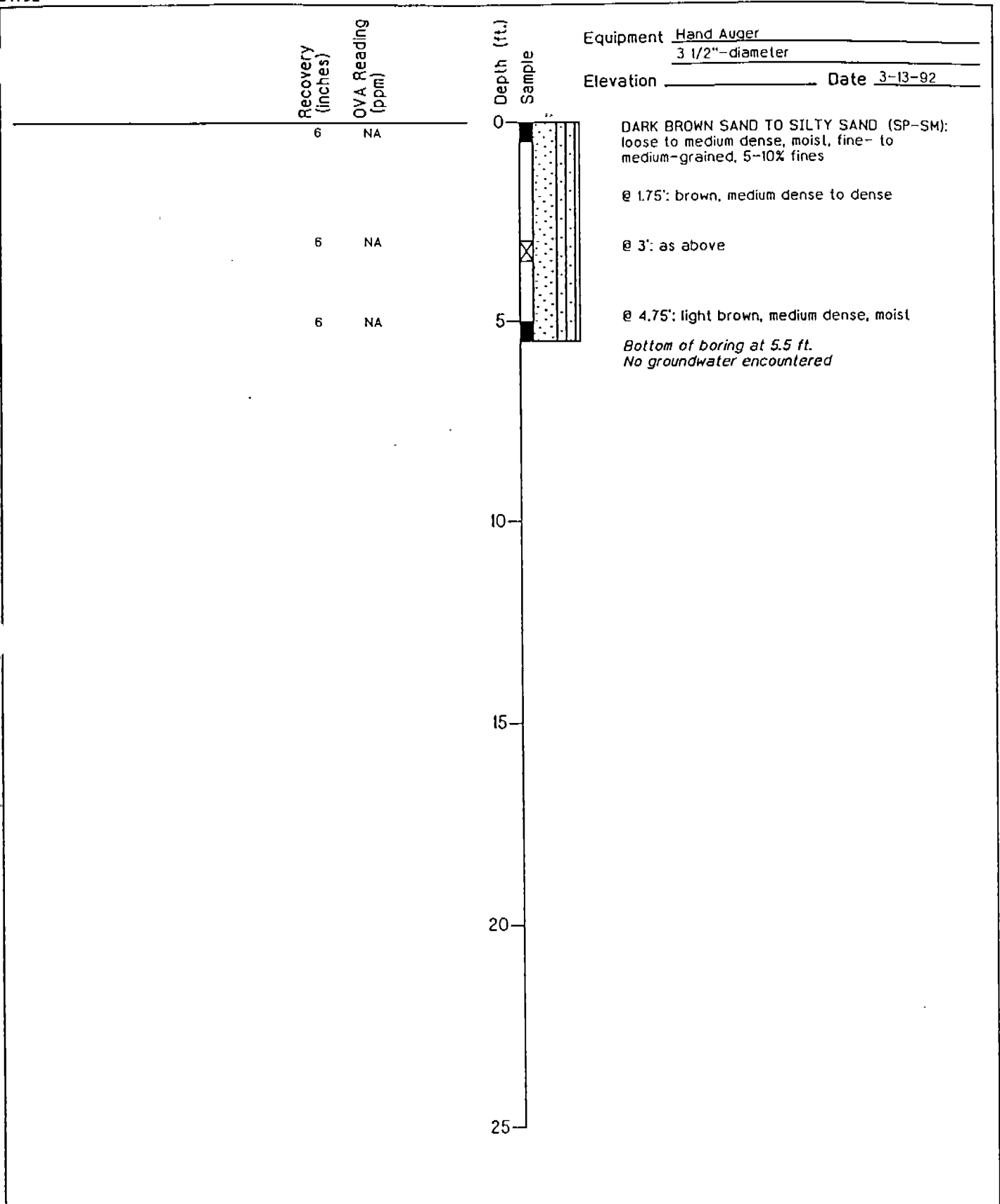

Harding Lawson Associates
 Engineering and
 Environmental Services

Log of Boring OF-16-08-01
 Basewide Surface Water Investigation
 Remedial Investigation
 Fort Ord, California

PLATE

A22

DRAWN
 CEG

JOB NUMBER
 07579,534.02

APPROVED

DATE
 06/92

REVISED DATE

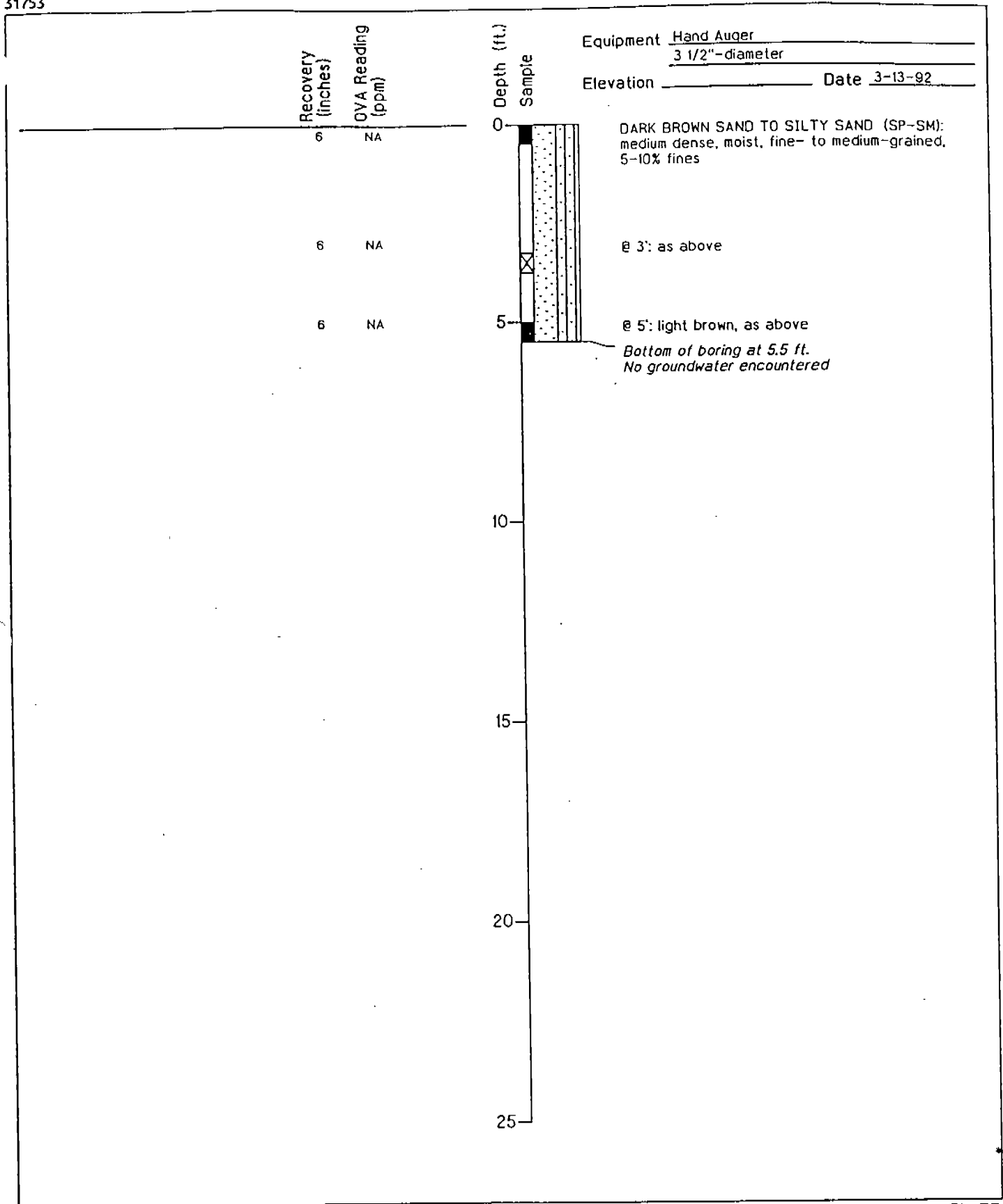

Harding Lawson Associates
Engineering and
Environmental Services

Log of Boring OF-18-08-02
Basewide Surface Water Investigation
Remedial Investigation
Fort Ord, California

PLATE

A23

DRAWN CEG
JOB NUMBER 07579,534.02

APPROVED
Jam

DATE 06/92

REVISED DATE

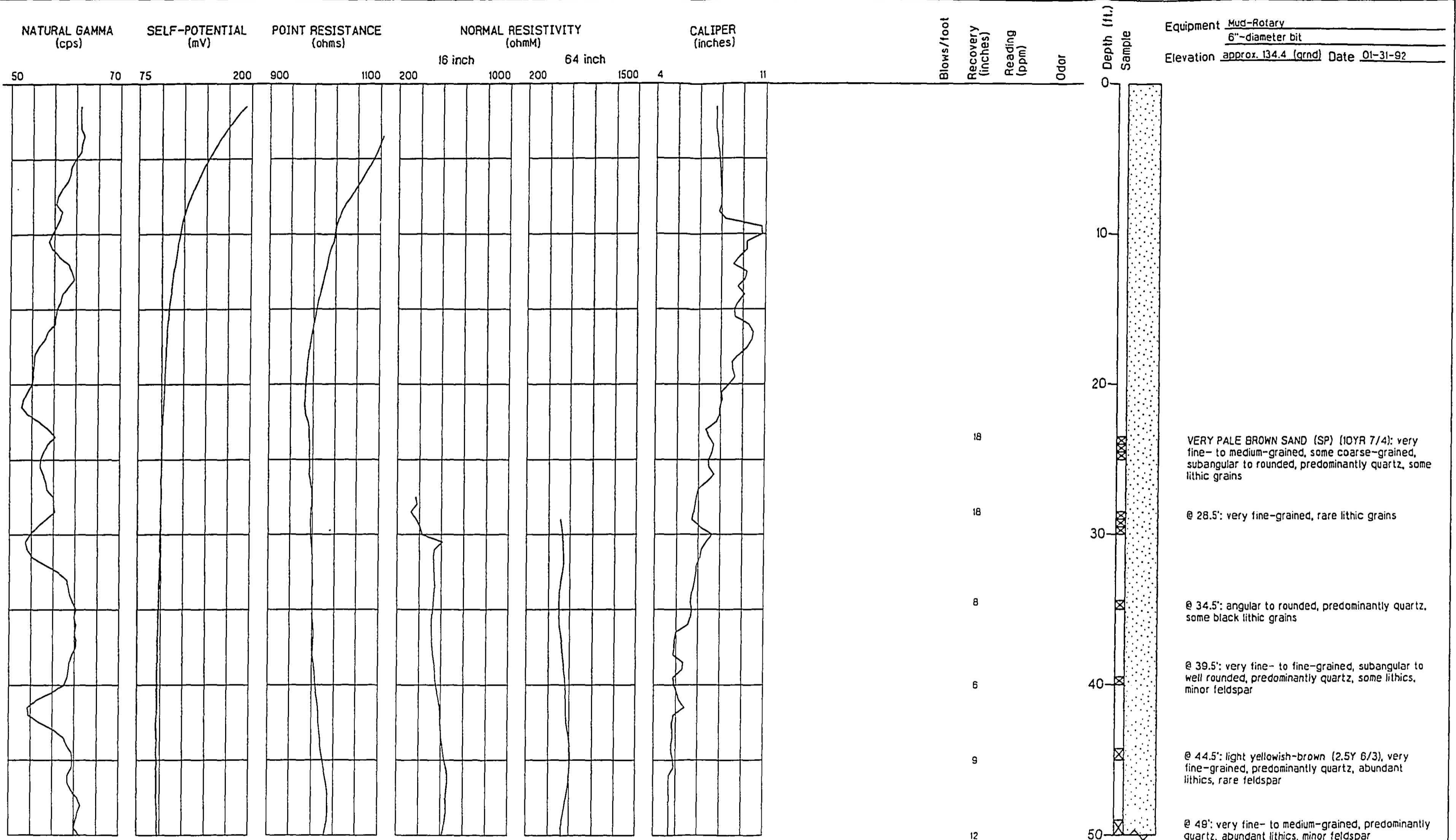

Equipment Mud-Rotary
6"-diameter bit
 Elevation approx. 134.4 (grnd) Date 01-31-92

Depth (ft.)
 0
 10
 20
 30
 40
 50

VERY PALE BROWN SAND (SP) (10YR 7/4): very fine- to medium-grained, some coarse-grained, subangular to rounded, predominantly quartz, some lithic grains

@ 28.5': very fine-grained, rare lithic grains

@ 34.5': angular to rounded, predominantly quartz, some black lithic grains

@ 39.5': very fine- to fine-grained, subangular to well rounded, predominantly quartz, some lithics, minor feldspar

@ 44.5': light yellowish-brown (2.5Y 6/3), very fine-grained, predominantly quartz, abundant lithics, rare feldspar

@ 49': very fine- to medium-grained, predominantly quartz, abundant lithics, minor feldspar

WELL DATA

Fluid Type Bentonite
 Mud Resistivity NA
 Mud Temperature 13 ° C
 Mud Conductivity NA

LOGGING SPEED

Natural Gamma 15 ft/min
 SP/PR 18 ft/min
 Normal Resistivity 20 ft/min
 Caliper 13 ft/min

If this image is not as legible as this overlay, it's due to the poor quality of the original document



Herding Lawson Associates
 Engineering and Environmental Services

Log of Boring PB-16-01
 Site Characterization
 Site 16 - DOL Maintenance Yard, Pete's Pond
 Fort Ord, California

PLATE

B30

DRAWN LNR	JOB NUMBER 10776 687	APPROVED <i>E B</i>	DATE 12/92	REVISED DATE
--------------	-------------------------	------------------------	---------------	--------------

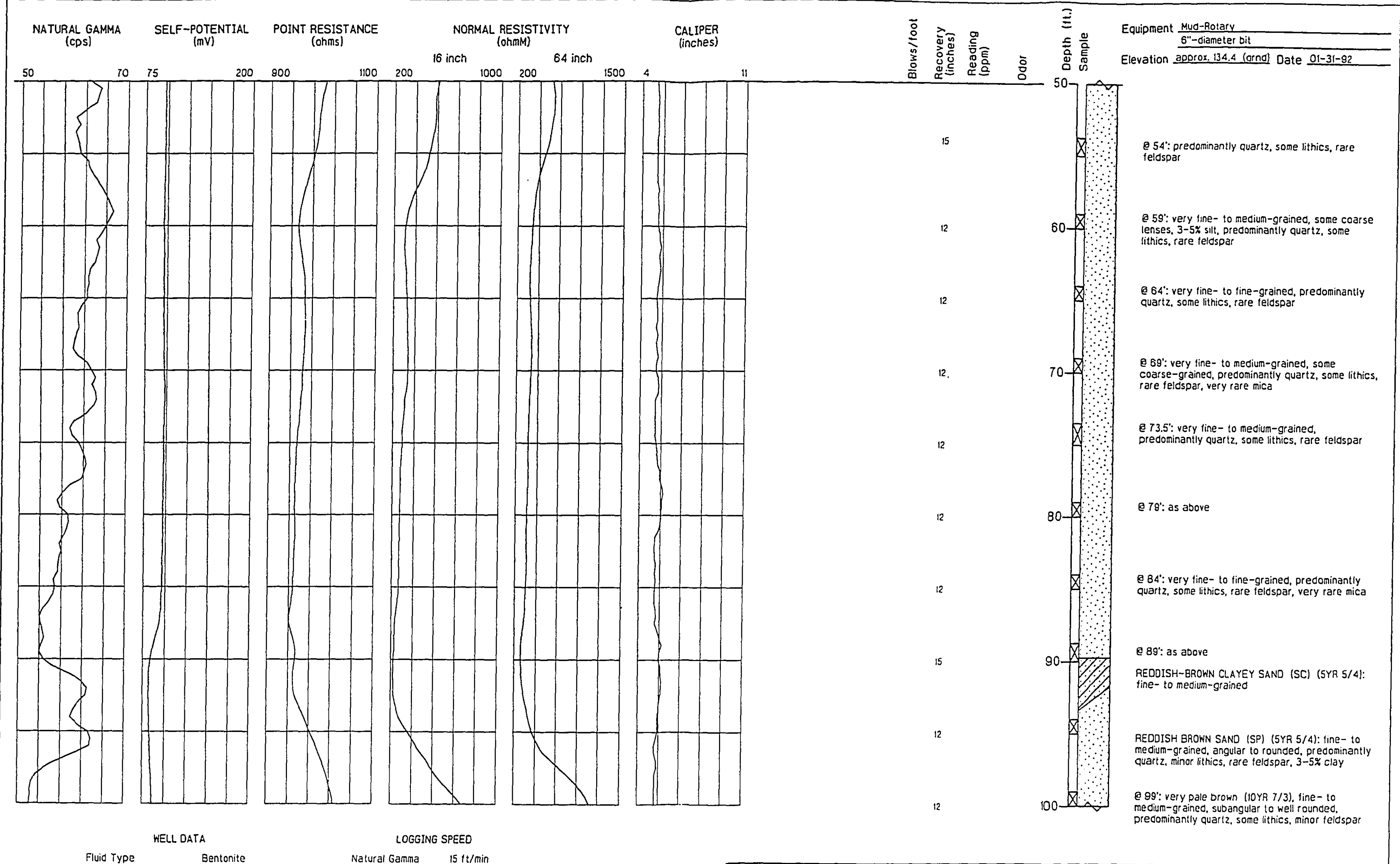

WELL DATA

Fluid Type Bentonite
 Mud Resistivity NA
 Mud Temperature 13 ° C
 Mud Conductivity NA

LOGGING SPEED

Natural Gamma 15 ft/min
 SP/PR 18 ft/min
 Normal Resistivity 20 ft/min
 Caliper 13 ft/min

If this image is not as legible as this overlay, it's due to the poor quality of the original document



Harding Lawson Associates
 Engineering and Environmental Services

Log of Boring PB-16-01
 Site Characterization
 Site 16 - DOL Maintenance Yard, Pete's Pond
 Fort Ord, California

PLATE

B30

DRAWN LNR	JOB NUMBER 10776 687	APPROVED [Signature]	DATE 12/92	REVISED DATE
--------------	-------------------------	-------------------------	---------------	--------------

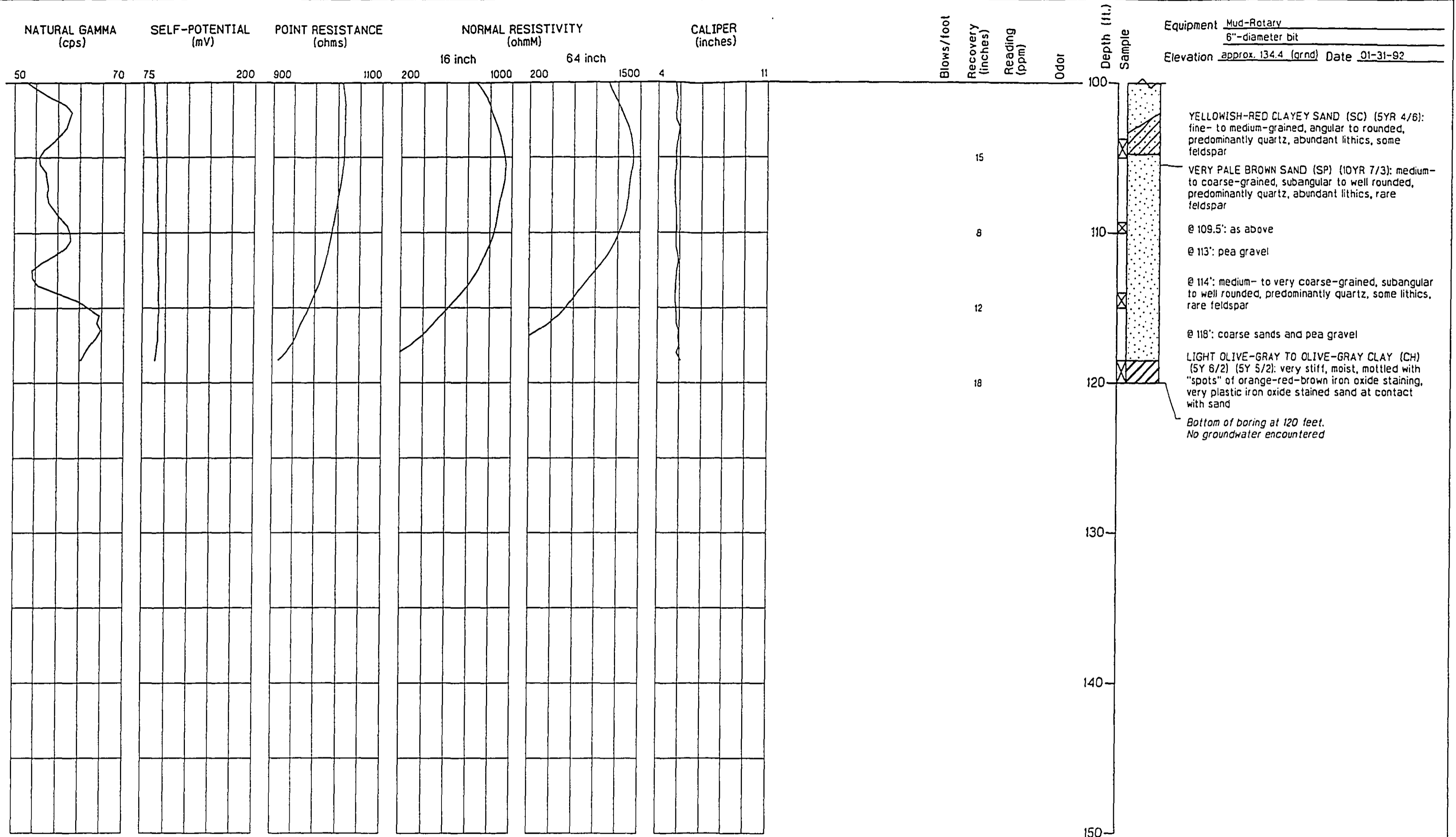

WELL DATA		LOGGING SPEED	
Fluid Type	Bentonite	Natural Gamma	15 ft/min
Mud Resistivity	NA	SP/PR	18 ft/min
Mud Temperature	13 °C	Normal Resistivity	20 ft/min
Mud Conductivity	NA	Caliper	13 ft/min

If this image is not as legible as this overlay, it's due to the poor quality of the original document

	Harding Lawson Associates Engineering and Environmental Services	Log of Boring PB-16-01 Site Characterization Site 16 - DOL Maintenance Yard, Pete's Pond Fort Ord, California	PLATE <h1>B30</h1>
	DRAWN LNR JOB NUMBER 10776 687 APPROVED <i>[Signature]</i> DATE 12/92 REVISED DATE		

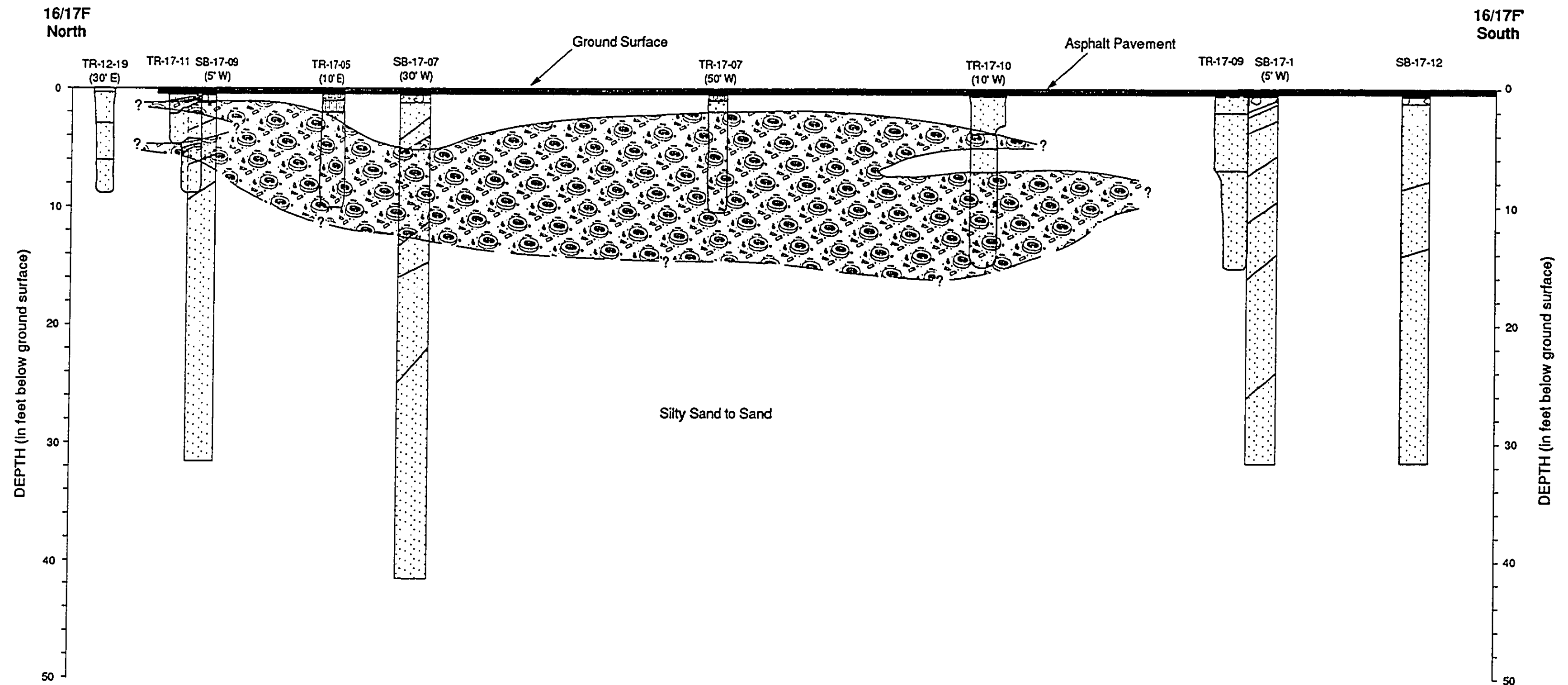

EXPLANATION

Extent of subsurface debris; dashed where inferred and queried where uncertain

Type designation
 SB - Soil Boring
 TR - Test Pit

SB-31-15
 Soil Boring or Test Pit number

Site number

(10' E)
 Distance and direction from cross-section line

Notes:

1. See Plate A1 in Appendix A for key to patterns
2. Location of cross section shown on Plate 5
3. The topography along the cross-section line is relatively flat at an approximate elevation of 150 feet MSL and has been shown as level. Elevations of soil borings and test pits were not surveyed.

If this image is not as legible as this overlay, it's due to the poor quality of the original document

Vertical Scale: 1" = 10'
 Horizontal Scale: 1" = 50'
 Vertical Exaggeration 5:1

NO.	DATE	REVISIONS	H/A FILE NO.	PROJECT NO.	APPROVED	APPROVAL DATE	DRAWN BY
1	7/94	DRAFT	340 071494AG	23366 041711			AO
2	12/94	DRAFT FINAL	340 112294LFD	23366 041721	RFM	11/21/94	

Harding Lawson Associates
 Engineering and
 Environmental Services

Volume II - Remedial Investigation
 Basewide RI/FS
 Fort Ord, California

Geologic Cross Section 16/17F- 16/17F
 Site 17 - Disposal Area

PLATE:

16/17E
SOUTHWEST

16/17E
NORTHEAST

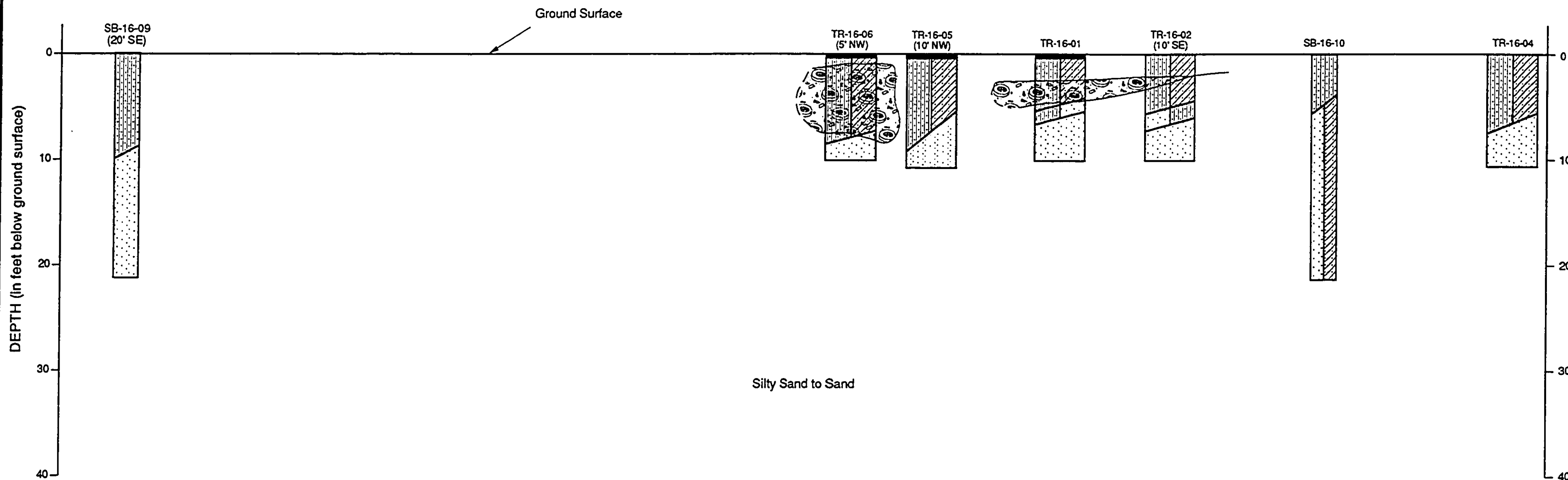

Silty Sand to Sand

EXPLANATION



Extent of suburface debris; dashed where inferred

Type designation
SB - Soil Boring
TR - Test Pit

SB-31-15

Soil Boring or Test Pit number

Site number

(10' E)

Distance and direction from cross-section line

Notes:

1. See Plate A1 in Appendix A for key to patterns
2. Location of cross section shown on Plate 4
3. The topography along the cross-section line is relatively flat at an approximate elevation of 130 feet MSL and has been shown as level. Elevations of soil borings and test pits were not surveyed.

If this image is not as legible as this overlay, it's due to the poor quality of the original document

Vertical Scale: 1" = 5'
Horizontal Scale: 1" = 25'
Vertical Exaggeration 5:1

NO.	DATE	REVISIONS	H/A FILE NO.	PROJECT NO.	APPROVED	APPROVAL DATE	DRAWN BY				PLATE:
1	7/04	DRAFT	mc071494AG	23366.041711			DJP	Harding Lawson Associates Engineering and Environmental Services	Volume II - Remedial Investigation Basewide RI/FS Fort Ord, California	Geologic Cross Section 16/17E- 16/17E' Site 16 - Pete's Pond	20
2	12/04	DRAFT FINAL	mc112294LFD	23366.041721	KEA	12/2/04					

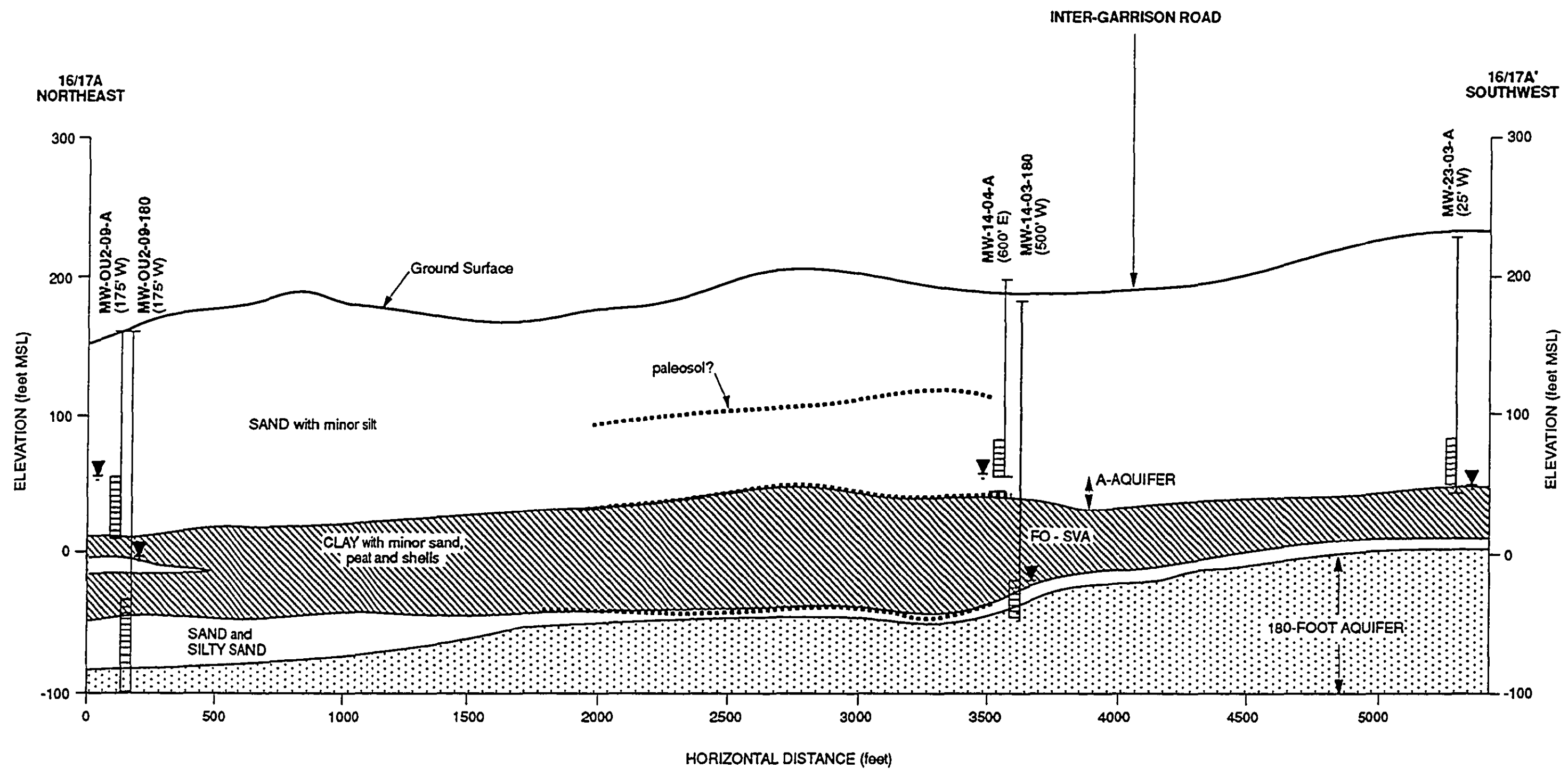

EXPLANATION

- Well/Boring Location Showing Screened Interval
- Static Water Level from HLA February 1994 Measurements
- Seismic Reflector from HLA 1991-1992 seismic reflection survey
- (10' E) Distance and direction from cross-section line

Lithologic Patterns*:

- Clay
- Sand
- Gravel

*Patterns are located in areas of borehole control; at distance from borings, the absence of a pattern indicates relatively poor subsurface control.

Note: Well data projected and interpreted as it would occur approximately at the cross section line.

Vertical Scale: 1" = 100'
 Horizontal Scale: 1" = 500'
 Vertical Exaggeration 5:1

If this image is not as legible as this overlay, it's due to the poor quality of the original document

NO.	DATE	REVISIONS	HLA FILE NO.	PROJECT NO.	APPROVED	APPROVAL DATE	DRAWN BY	Harding Lawson Associates Engineering and Environmental Services	Volume II - Remedial Investigation Basewide RI/FS Fort Ord, California	Regional Geologic Cross Section 16/17A-16/17A' Sites 16 and 17	PLATE:
1	7/94	DRAFT	mc071494AG	2306 04 1711			DJP				
2	12/94	DRAFT FINAL	mc112294LFD	2334 04 1721	<i>RFP</i>	<i>1/11/94</i>					12

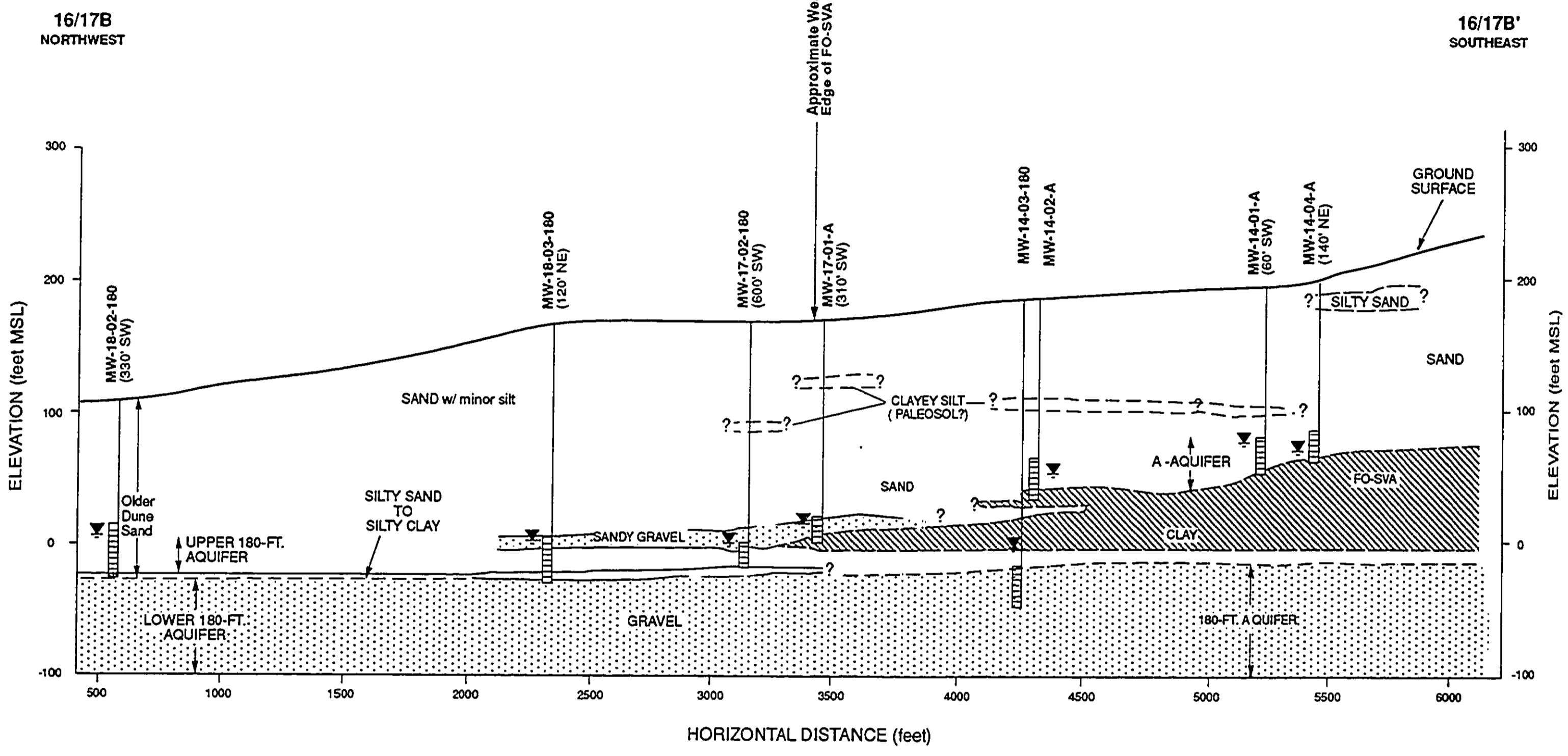

EXPLANATION

Well/Boring Location Showing Screened Interval

Static Water Level from HLA February 1994 Measurements

(10' E) Distance and direction from cross-section line

Note: Well data projected and interpreted as it would occur approximately at the cross section line.

Lithologic Patterns*:

Clay

Sand

Gravel

*Patterns are located in areas of borehole control; at distance from borings, the absence of a pattern indicates relatively poor subsurface control.

Vertical Scale: 1" = 100'
 Horizontal Scale: 1" = 500'
 Vertical Exaggeration 5:1

If this image is not as legible as this overlay, it's due to the poor quality of the original document

NO.	DATE	REVISIONS	HLA FILE NO.	PROJECT NO.	APPROVED	APPROVAL DATE	DRAWN BY	Harding Lawson Associates Engineering and Environmental Services	Volume II - Remedial Investigation Basewide RI/FS Fort Ord, California	Regional Geologic Cross Section 16/17B-16/17B' Sites 16 and 17	PLATE:
1	7/94	DRAFT	mc071494AG	23366 041711			DJP				
2	12/94	DRAFT FINAL	mc112294LFD	23366 041721	REMA	11/21/94					

PHYSICAL TESTING STANDARDS FOR SOIL

The following physical testing was performed as part of the remedial investigation (RI) for these sites. Physical tests were performed during the RI to provide data for the evaluation of fate and transport of chemicals and of remedial action alternatives for the feasibility study. Descriptions of the physical testing conducted follow:

- Particle Size Analysis (Sieve Analysis): This test is described in detail in ASTM Standard D 422 (Method for Particle-Size Analysis of Soil) and determines the particle size distribution of the soil. Information from this test is used by the laboratory to determine the classification of soil in accordance with the Uniform Soil Classification System (USCS). Field and laboratory classifications of some soil samples sometimes differ. Soil borings were logged by HLA geologists or engineers in the field using ASTM D 2488-90 (Practice for Description and Identification of Soil [Visual-Manual Procedure]). The differences in classifications are partly the result of the natural differences between quantitative laboratory results and the subjective element in qualitative visual or manual field classification. In addition, the field method classifies sand with more than 15 percent fines as silty or clayey sand, whereas the laboratory method uses 12 percent fines for this threshold.
- Atterberg Limits: This test is described in detail in ASTM Standard D 4318 (Test Method for Liquid Limit, Plastic Limit, and Plasticity Index of Soil) and determines the plastic and liquid limits of soil. Soil can be solid, liquid, or plastic depending on the moisture content. Water contents at which soil changes (1) from solid to plastic and (2) from plastic to liquid are called the Atterberg limits, known individually as the plastic limit and liquid limit, respectively. High liquid limits generally indicate a high clay content in the soil and a low load-carrying capacity. The difference between the liquid and plastic limits is known as the plasticity index. A low plasticity index generally indicates that a relatively small amount of moisture will change the soil from a semisolid to a liquid. A high plasticity index (generally greater than 20) indicates that considerable water may be added to the soil before it reaches a liquid condition. Sandy soil with low clay contents, such as those often found at Fort Ord, typically have low liquid limits and are non-plastic (have no plastic limit).
- Organic Content: This test is described in detail in ASTM Standard D 2974 (Test Methods for Moisture, Ash, and Organic Matter of Peat and Other Organic Soil). This test measures the amount of organic matter in the soil. The organic content indicated by this test can be used to evaluate the sorptive properties of the soil and the potential for methane gas generation.
- Swell Consolidation: This test is described in detail in ASTM Standard D 4546 (Test Methods for One-Dimensional Swell or Settlement Potential of Cohesive Soil). Results of this test can be used to estimate the total amount of soil consolidation under various future loading conditions, as well as the swell or expansion of the soil once such loading is removed.
- Modified Proctor Compaction: This test is described in detail in ASTM Standard D 1557 (Test Methods for Moisture-Density Relations of Soil and Soil-Aggregate Mixtures using a 10 Pound Rammer and 18 Inch Drop). This test is used to determine the optimum moisture content and density of the soil. Optimum moisture content and density are used in developing backfill and site grading/compaction requirements. (Specified compactions are often expressed as 90 to 100 percent relative compaction relative to these optimal conditions.)
- Specific Gravity: This test is performed in accordance with ASTM D 854 (Test Method for Specific Gravity of Soil). The specific

gravity of soil can be used with the dry density to calculate soil porosity, void ratio, percent saturation, and moisture content. These values give an indication of actual field conditions. The porosity of soil can also be used to qualitatively evaluate the permeability of soil by indicating the amount of pore space present in the sample.

- Moisture Content and Dry Density: Moisture content of soil is determined in accordance with ASTM Standard D 2216 (Method for Laboratory Determination of Water [Moisture] Content of Soil, Rock, and Soil-Aggregate Mixtures). The moisture content of the soil can be used to evaluate the capillary fringe of a groundwater table and the effectiveness of soil vapor extraction or bioremediation of soil.

The moisture content of the soil is also used to determine the maximum dry density of soil. A cylindrical soil sample is measured for height, diameter, and wet weight in the laboratory and the actual wet density of the soil is calculated. The dry density is then calculated by dividing the actual density by one plus the moisture content. Dry density is required in many geotechnical test methods, as well as for the general evaluation of soil properties.

- Hydraulic Conductivity: Two ASTM tests can be used to determine hydraulic conductivity. Sandy uncohesive soil, such as those typically found at Fort Ord, are usually tested for hydraulic conductivity using ASTM Standard D 2434 (Test Method for Permeability of Granular Soil, Constant Head). For silty and/or clayey soil, ASTM Standard D 5084 (Test Method for Permeability of Granular Soil, Falling Head) is used to measure hydraulic conductivity. Hydraulic conductivity values can be used to estimate the leachability potential of the soil and to design landfill liners and caps. Hydraulic conductivity can also be used for groundwater modeling or for estimating the flow of water through soil.
- Air Permeability: This test is performed using a modified ASTM Standard D 4525

test. The normal ASTM D 4525 (Test Method for Permeability of Rocks by Flowing Air) test is used to measure the conductivity of air through rock. This procedure was slightly modified by the analytical laboratory (see attached laboratory sheets). Soil permeability is a measure of continuous voids throughout the sample and of the ease with which liquids (air or water) can migrate through them. Air permeability results can be used to aid in determining the effectiveness of certain remedial technologies such as air sparging, soil vapor extraction, and bioventing.

- Hveem Stabilometer or R-Value: This test is described in detail in ASTM Standard D 2844 (Test Method for Resistance R-Value and Expansion Pressure of Compacted Soil). The R-value is measured using a Hveem stabilometer, and ranges from 0 (the resistance of water) to 100 (the resistance of steel). This test measures the resistance of a soil to lateral deformation when a vertical load is applied to it. When displacement occurs, the soil moves out and away from the applied load. R-values are used in the design of asphalt pavements or caps that must support vehicular or other loadings.

U.S. Standard Sieve Size (in.) U.S. Standard Sieve Numbers Hydrometer

3 1½ ¾ ⅜ 4 8 16 30 40 50 100 200

Reference: ASTM D 422

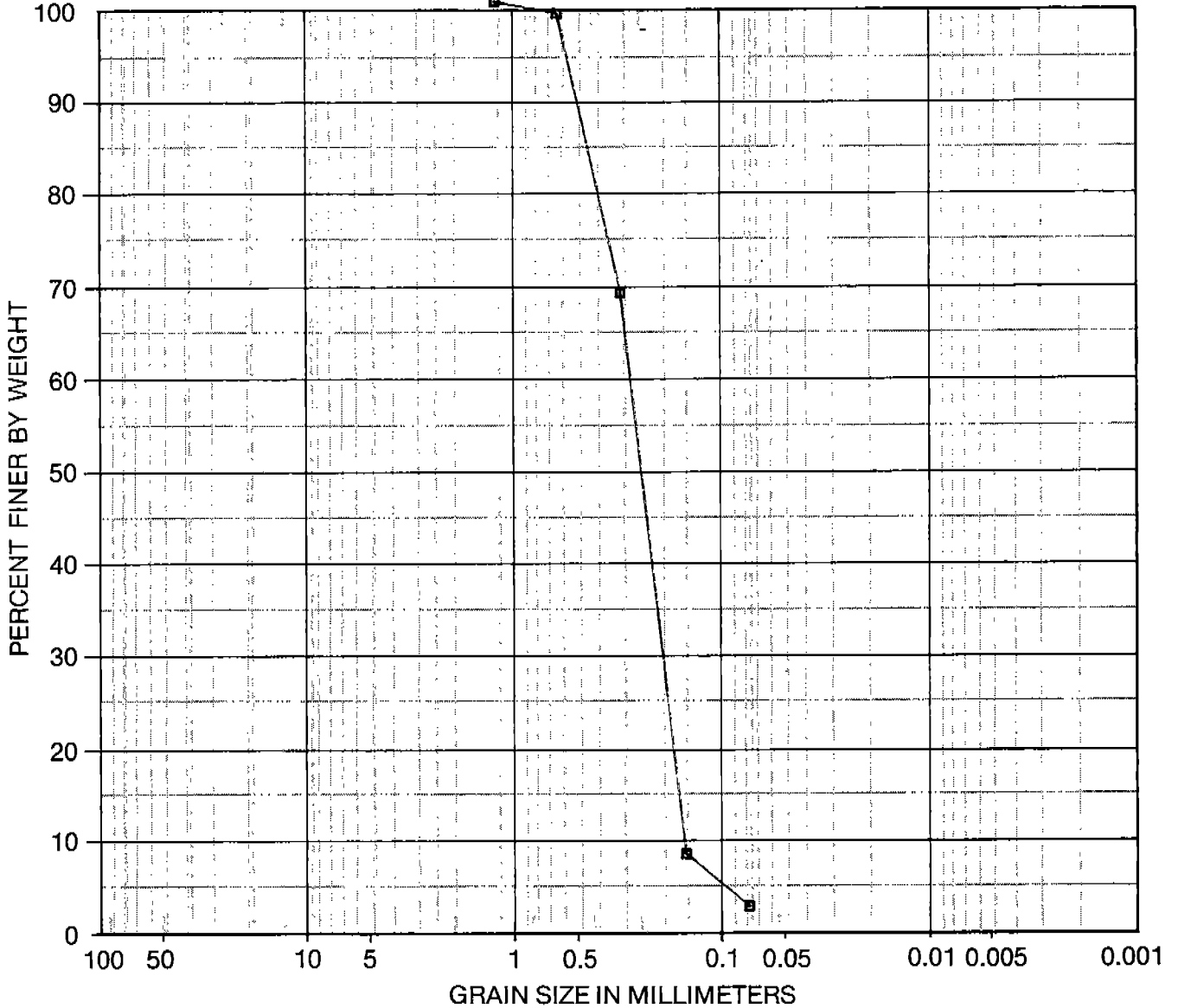

COBBLES	COARSE	FINE	COARSE	MEDIUM	FINE	SILT OR CLAY
	GRAVEL		SAND			

Symbol	Sample Source	Classification
■	SB-16-01 @ 21.0 FT	LIGHT BROWN SAND (SP)



Harding Lawson Associates
Engineers, Geologists
& Geophysicists

Particle Size Analysis - Boring SB-16-01
Site Characterization
Site 16 - DOL Maintenance Yard, Pete's Pond
Fort Ord, California

PLATE

C1

DRAWN

JOB NUMBER
07579.687.02

APPROVED

DATE
04-02-1992

REVISED

DATE

U.S. Standard Sieve Size (in.) U.S. Standard Sieve Numbers Hydrometer

3 1½ ¾ ⅜ 4 8 16 30 40 50 100 200

Reference: ASTM D 422

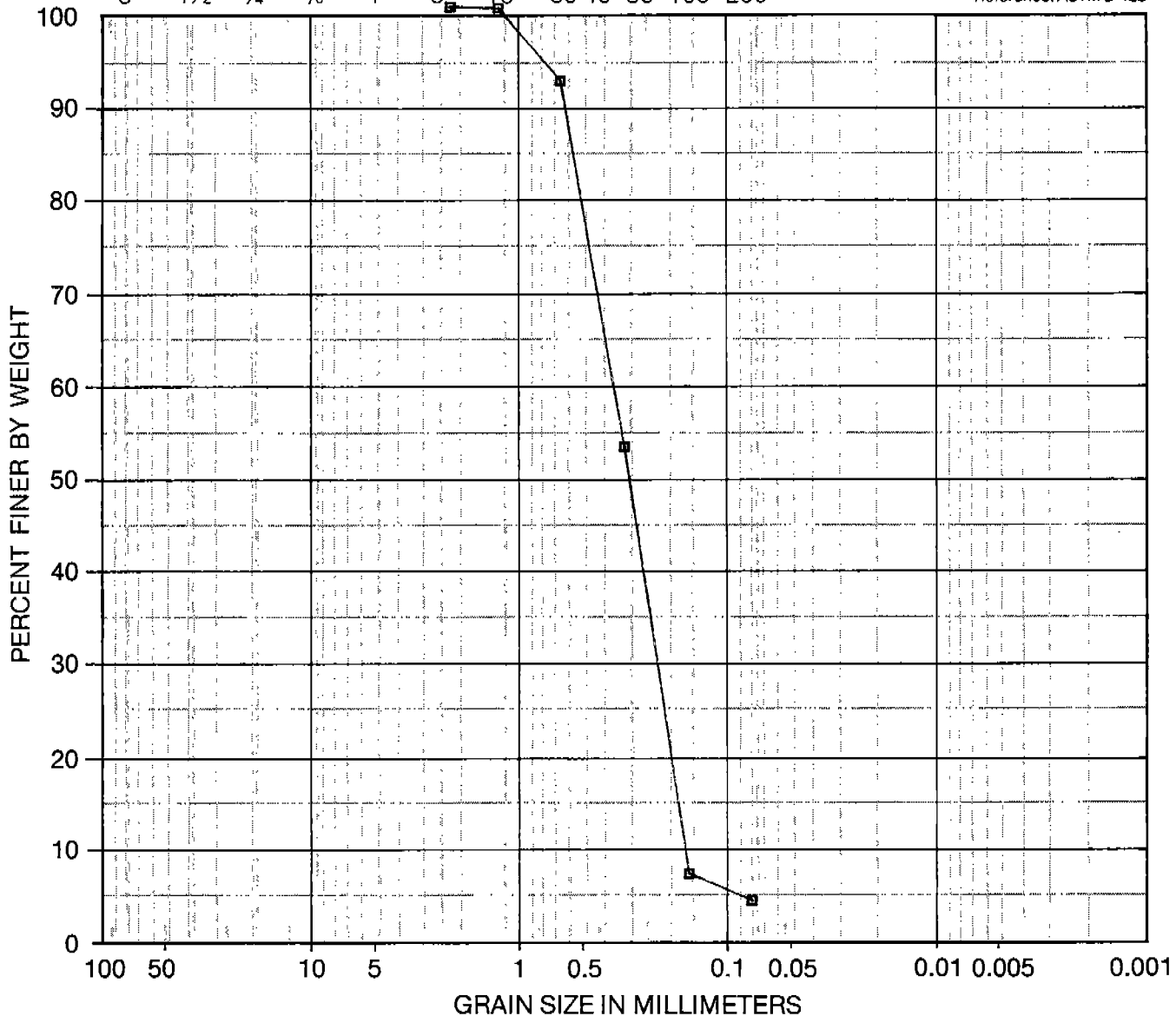

COBBLES	COARSE	FINE	COARSE	MEDIUM	FINE	SILT OR CLAY
	GRAVEL		SAND			

Symbol	Sample Source	Classification
■	SB-16-02 @ 15.5 FT	YELLOW-BROWN SAND (SP)



Harding Lawson Associates
Engineers, Geologists
& Geophysicists

Particle Size Analysis - Boring SB-16-02
Site Characterization
Site 16 - DOL Maintenance Yard, Pete's Pond
Fort Ord, California

PLATE

C2

U.S. Standard Sieve Size (in.) U.S. Standard Sieve Numbers Hydrometer

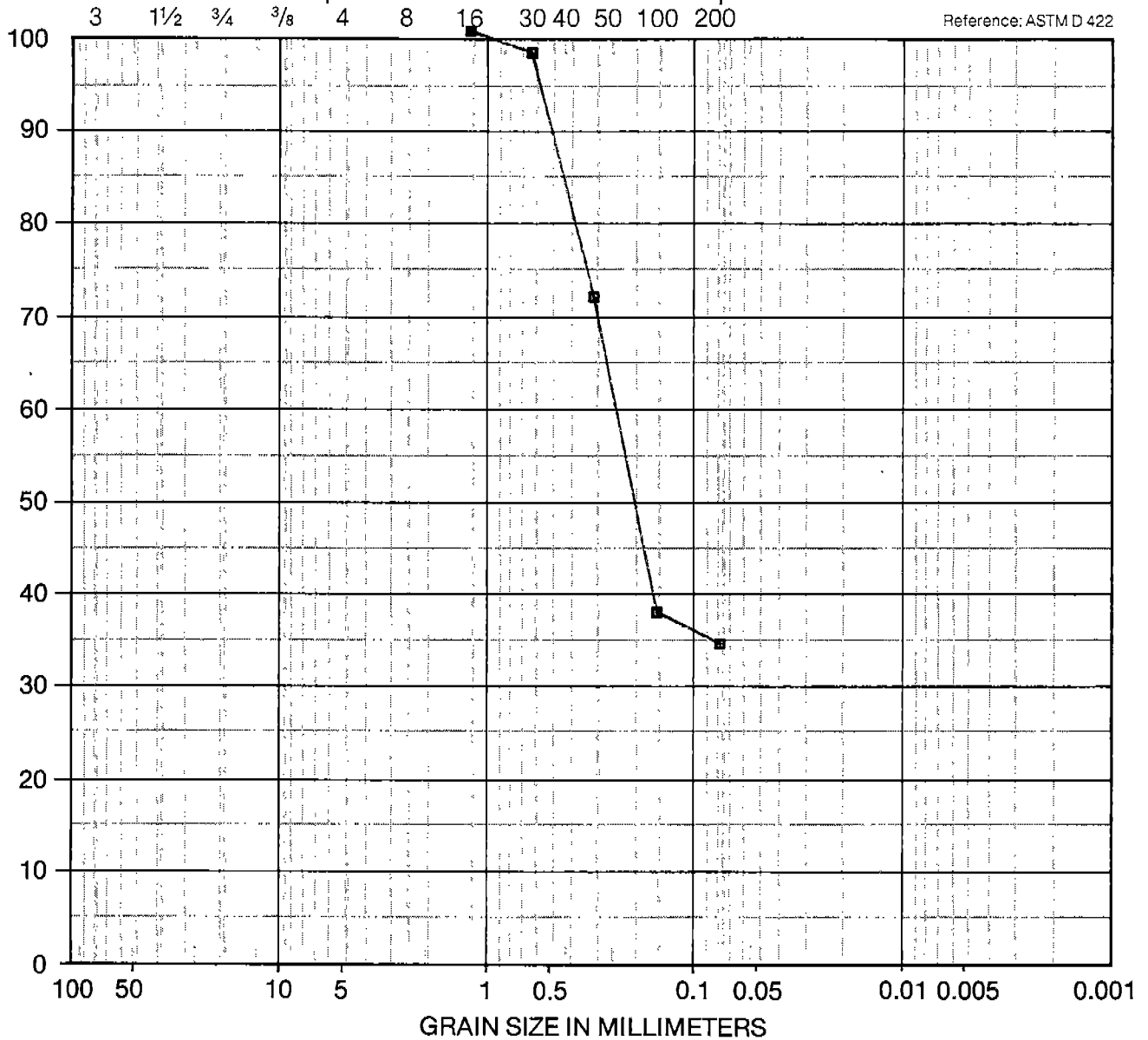

Reference: ASTM D 422

COBBLES	COARSE	FINE	COARSE	MEDIUM	FINE	SILT OR CLAY
	GRAVEL		SAND			

Symbol	Sample Source	Classification
■	SB-16-03 @ 20.5 FT	YELLOW-BROWN CLAYEY SAND (SC)



Harding Lawson Associates
Engineers, Geologists
& Geophysicists

Particle Size Analysis - Boring SB-16-03
Site Characterization
Site 16 - DOL Maintenance Yard, Pete's Pond
Fort Ord, California

PLATE

C3

DRAWN

JOB NUMBER
07579.687.02

APPROVED

HH

DATE
03-25-1992

REVISED

DATE

U.S. Standard Sieve Size (in.) U.S. Standard Sieve Numbers Hydrometer

3 1½ ¾ ⅜ 4 8 16 30 40 50 100 200

Reference: ASTM D 422

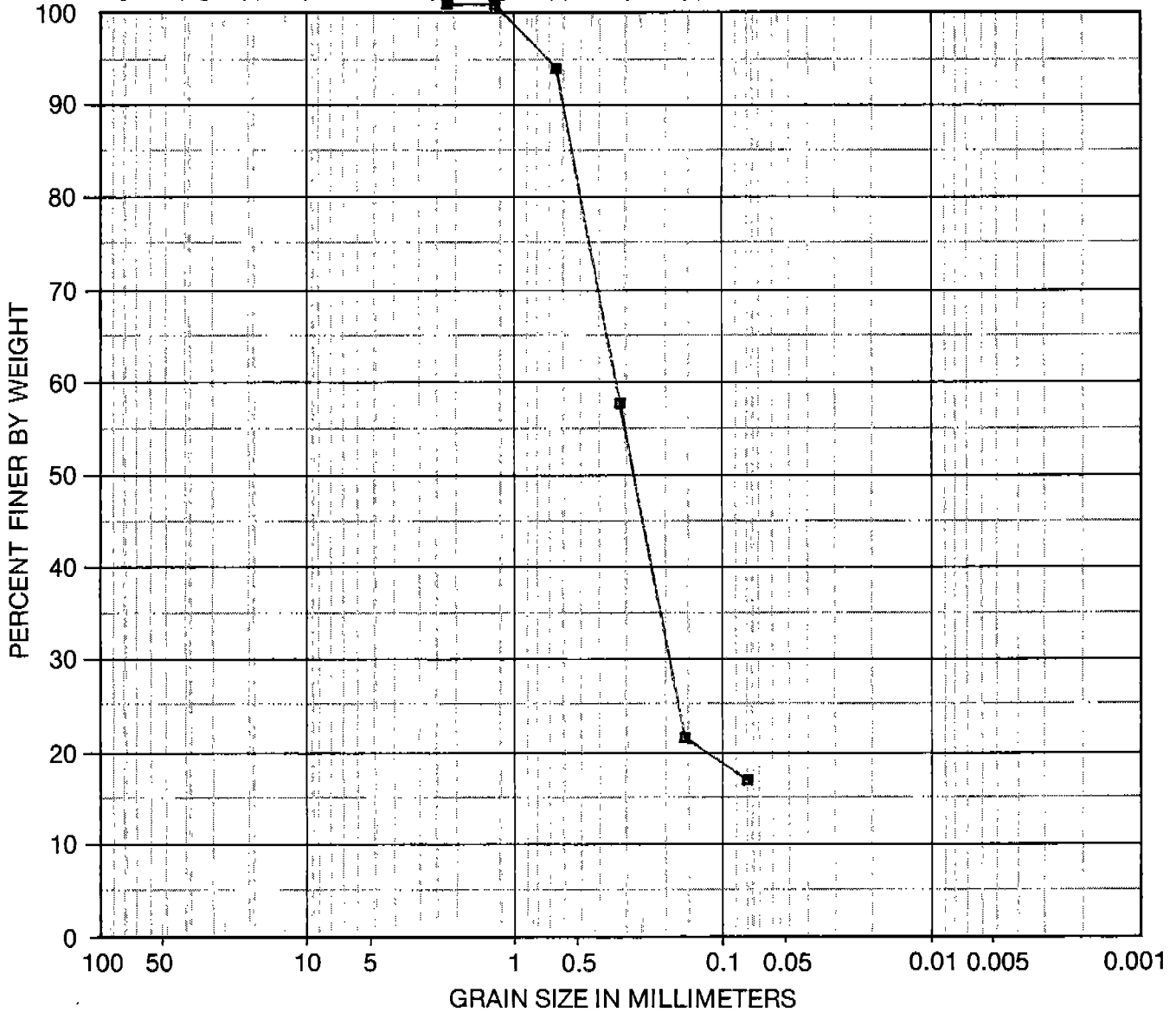

COBBLES	COARSE	FINE	COARSE	MEDIUM	FINE	SILT OR CLAY
	GRAVEL		SAND			

Symbol	Sample Source	Classification
■	SB-16-04 @ 10.5 FT	DARK BROWN CLAYEY SAND (SC)



Harding Lawson Associates
Engineers, Geologists
& Geophysicists

Particle Size Analysis - Boring SB-16-04
Site Characterization
Site 16 - DOL Maintenance Yard, Pete's Pond
Fort Ord, California

PLATE

C4

DRAWN

JOB NUMBER
07579.687.02

APPROVED
EH

DATE
03-25-1992

REVISED

DATE

U.S. Standard Sieve Size (in.) U.S. Standard Sieve Numbers Hydrometer

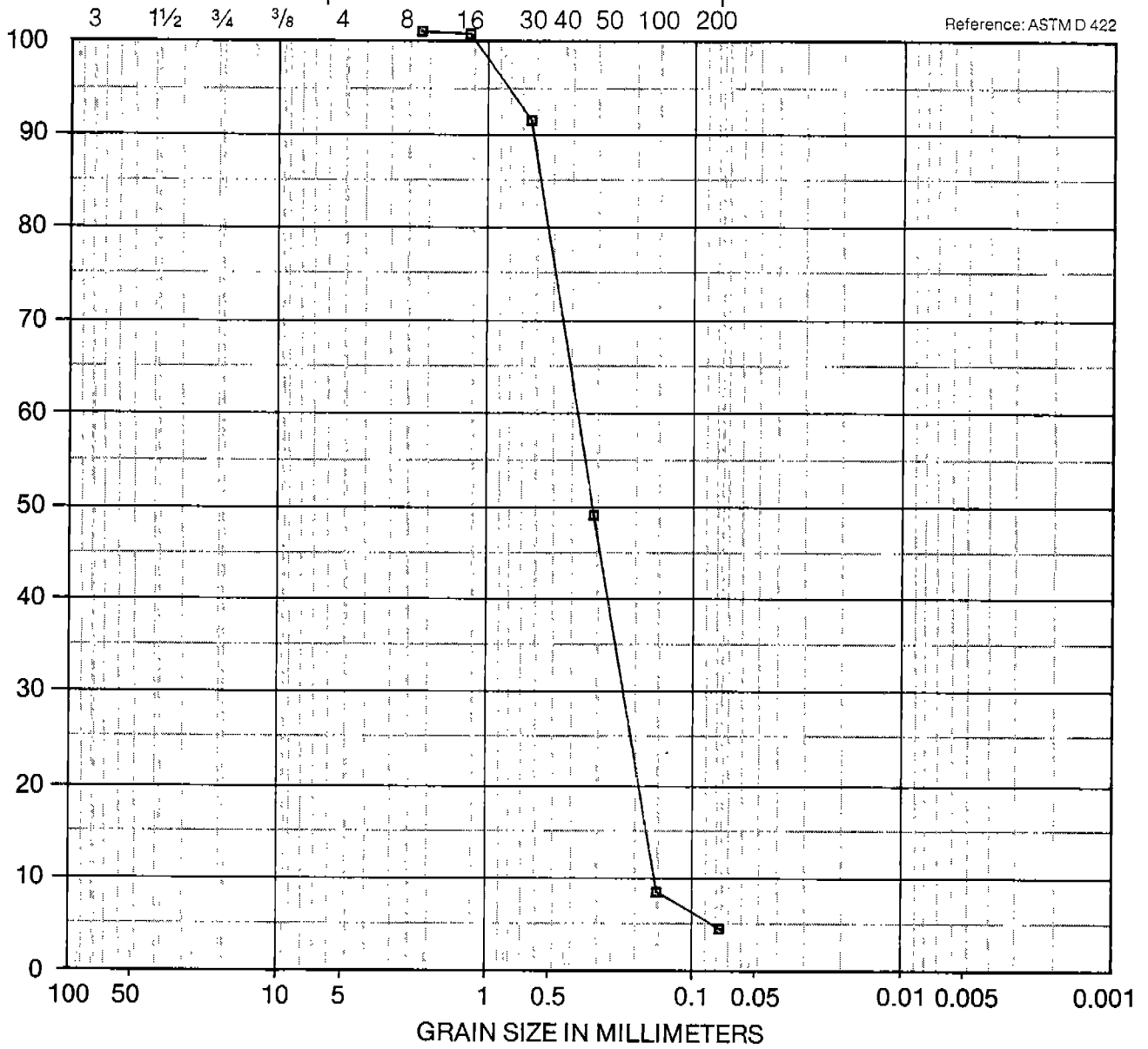

Reference: ASTM D 422

COBBLES	COARSE	FINE	COARSE	MEDIUM	FINE	SILT OR CLAY
	GRAVEL		SAND			

Symbol	Sample Source	Classification
■	SB-16-05 @ 14.0 FT	YELLOW-BROWN SAND (SP)



Harding Lawson Associates
Engineers, Geologists
& Geophysicists

Particle Size Analysis - Boring SB-16-05
Site Characterization
Site 16 - DOL Maintenance Yard, Pete's Pond
Fort Ord, California

PLATE

C5

DRAWN

JOB NUMBER
07579.687.02

APPROVED

DATE
03-26-1992

REVISED

DATE

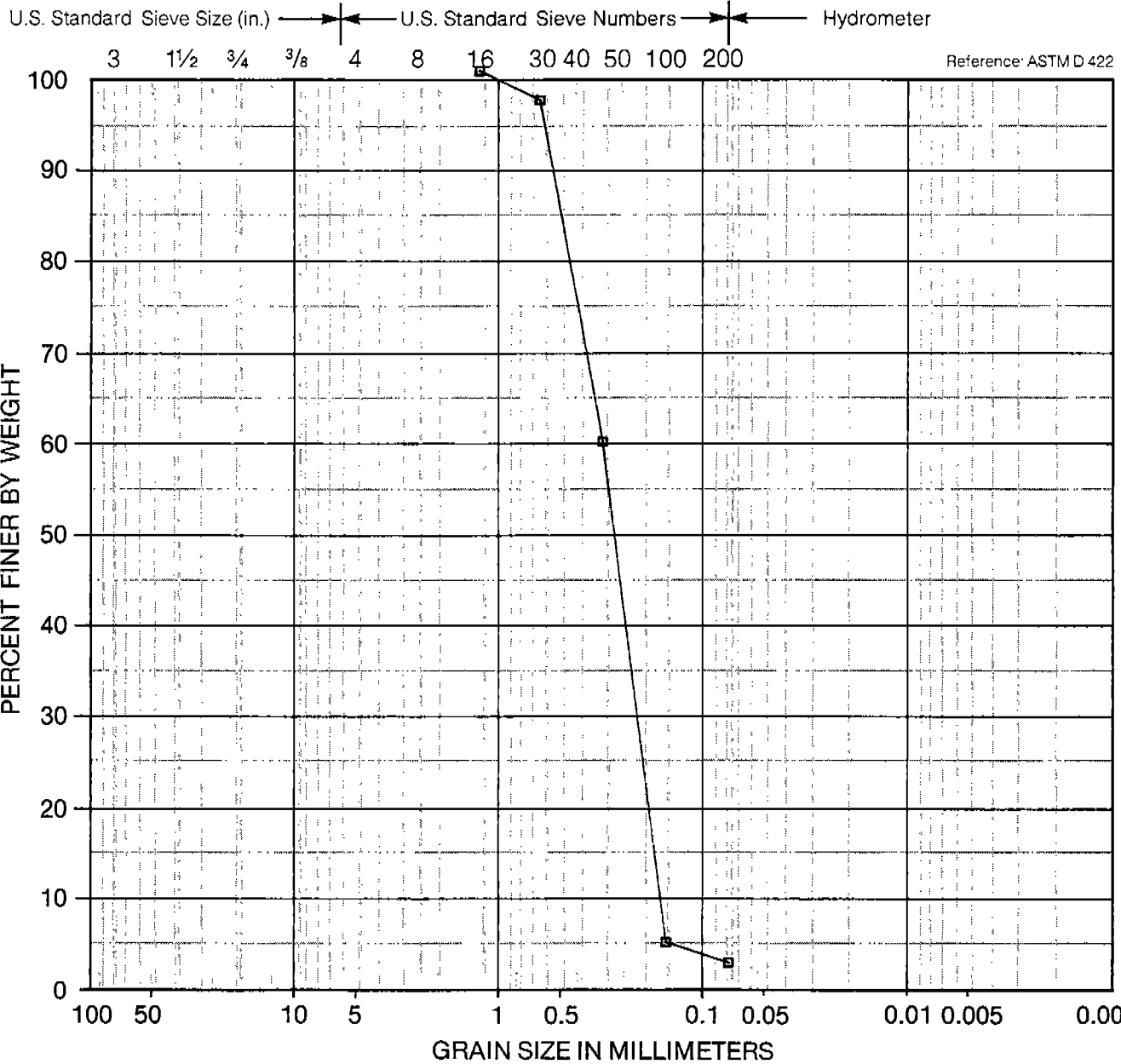

COBBLES	COARSE	FINE	COARSE	MEDIUM	FINE	SILT OR CLAY
	GRAVEL		SAND			

Symbol	Sample Source	Classification
■	SB-16-07 @ 20.5 FT	YELLOW-BROWN SAND (SP)



Harding Lawson Associates
 Engineers, Geologists
 & Geophysicists

Particle Size Analysis - Boring SB-16-07
 Site Characterization
 Site 16 - DOL Maintenance Yard, Pete's Pond
 Fort Ord, California

PLATE

C7

DRAWN

JOB NUMBER
07579.687.02

APPROVED

DATE
03-25-1992

REVISED

DATE

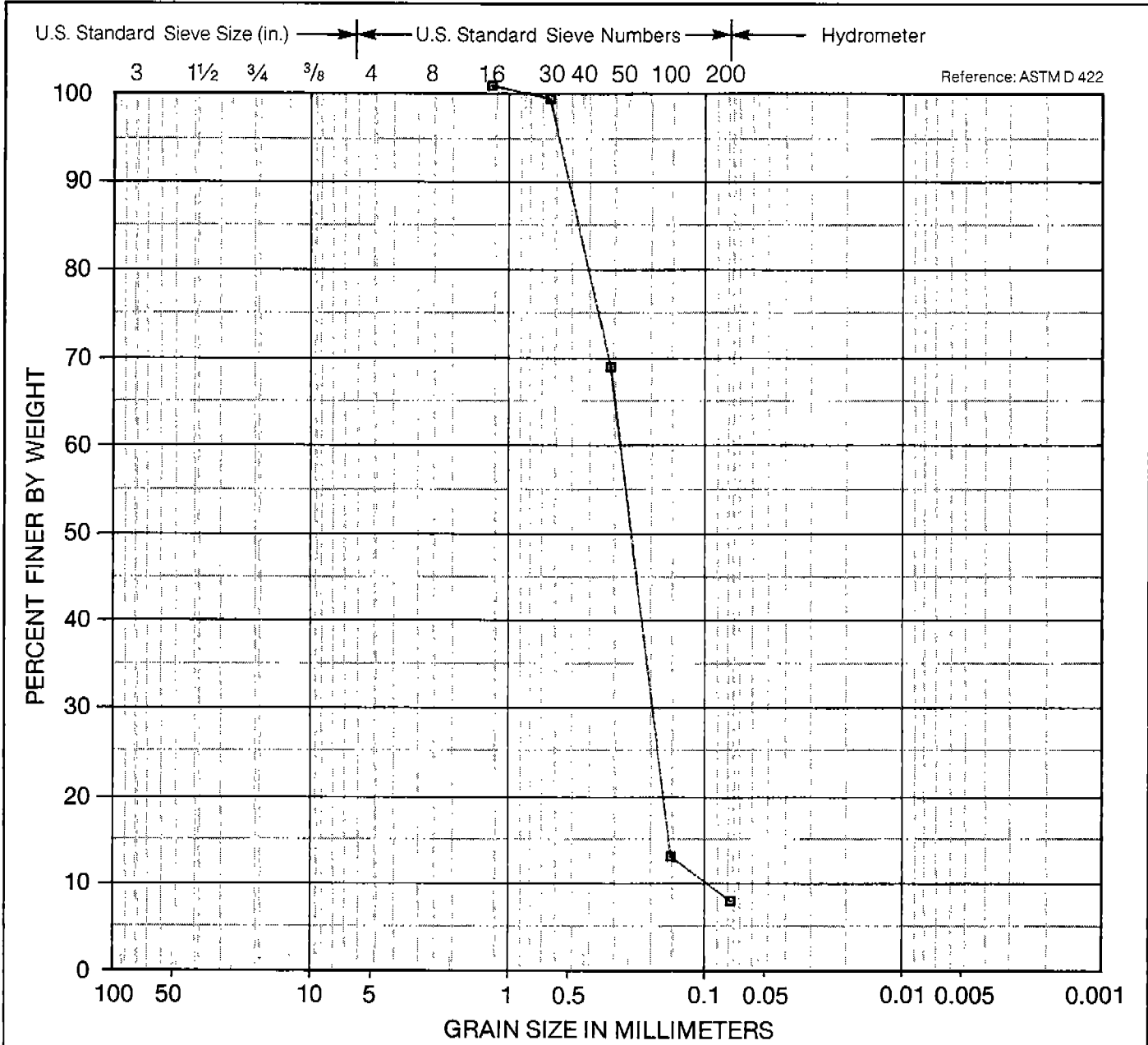

COBBLES	COARSE	FINE	COARSE	MEDIUM	FINE	SILT OR CLAY
	GRAVEL		SAND			

Symbol	Sample Source	Classification
B	SB-16-08 @ 20.0 FT	LIGHT BROWN SAND W/CLAY (SP-SC)



Harding Lawson Associates
 Engineers, Geologists
 & Geophysicists

Particle Size Analysis - Boring SB-16-08
 Site Characterization
 Site 16 - DOL Maintenance Yard, Pete's Pond
 Fort Ord, California

PLATE

C8

U.S. Standard Sieve Size (in.) U.S. Standard Sieve Numbers Hydrometer

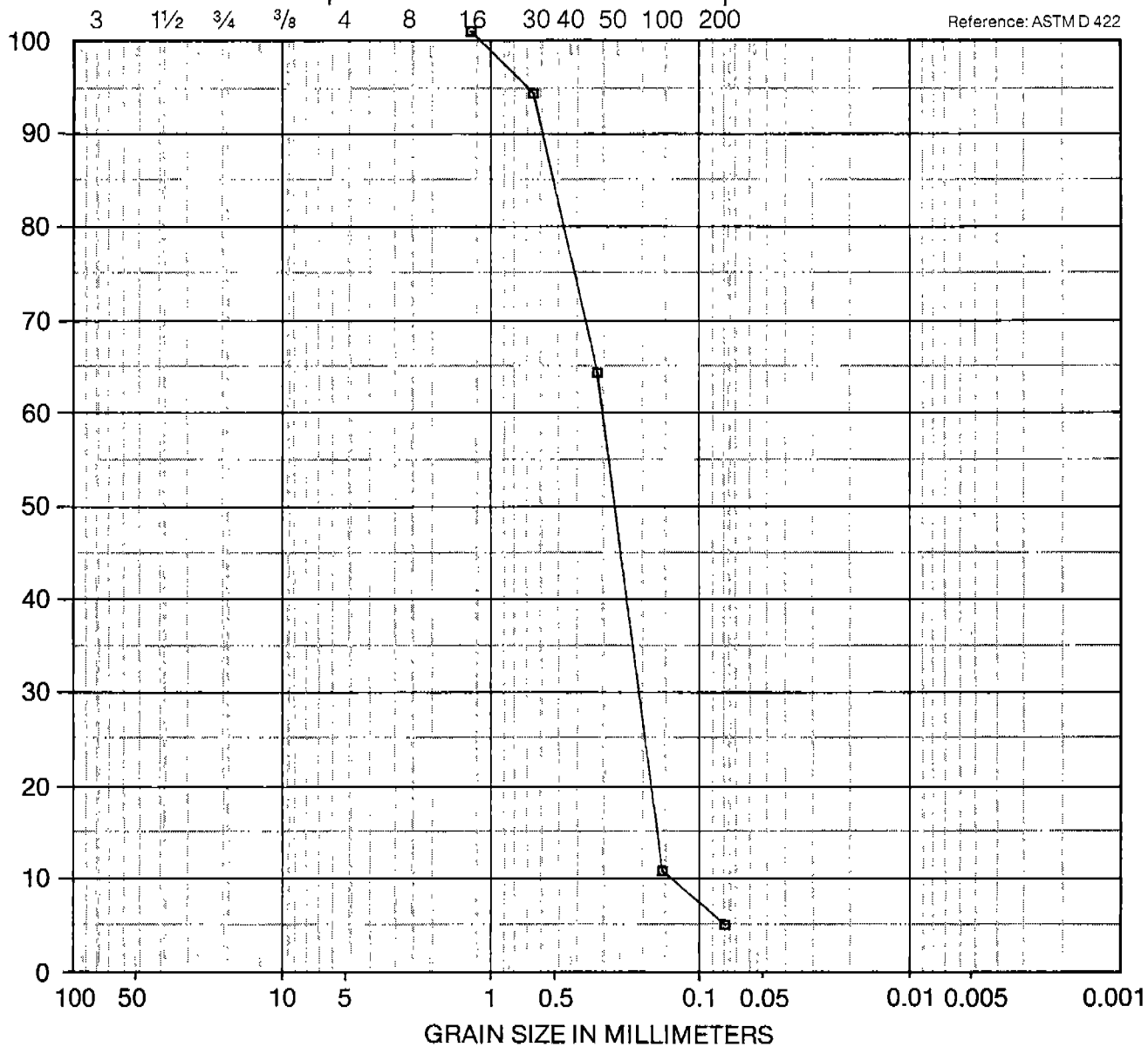

COBBLES	COARSE	FINE	COARSE	MEDIUM	FINE	SILT OR CLAY
	GRAVEL		SAND			

Symbol	Sample Source	Classification
■	SB-16-09 @ 15.5 FT	LIGHT BROWN SAND (SP)



Harding Lawson Associates
 Engineers, Geologists
 & Geophysicists

Particle Size Analysis - Boring SB-16-09
 Site Characterization
 Site 16 - DOL Maintenance Yard, Pete's Pond
 Fort Ord, California

PLATE

C9

U.S. Standard Sieve Size (in.) ← → U.S. Standard Sieve Numbers ← → Hydrometer

3 1½ ¾ ⅜ 4 8 16 30 40 50 100 200

Reference: ASTM D 422

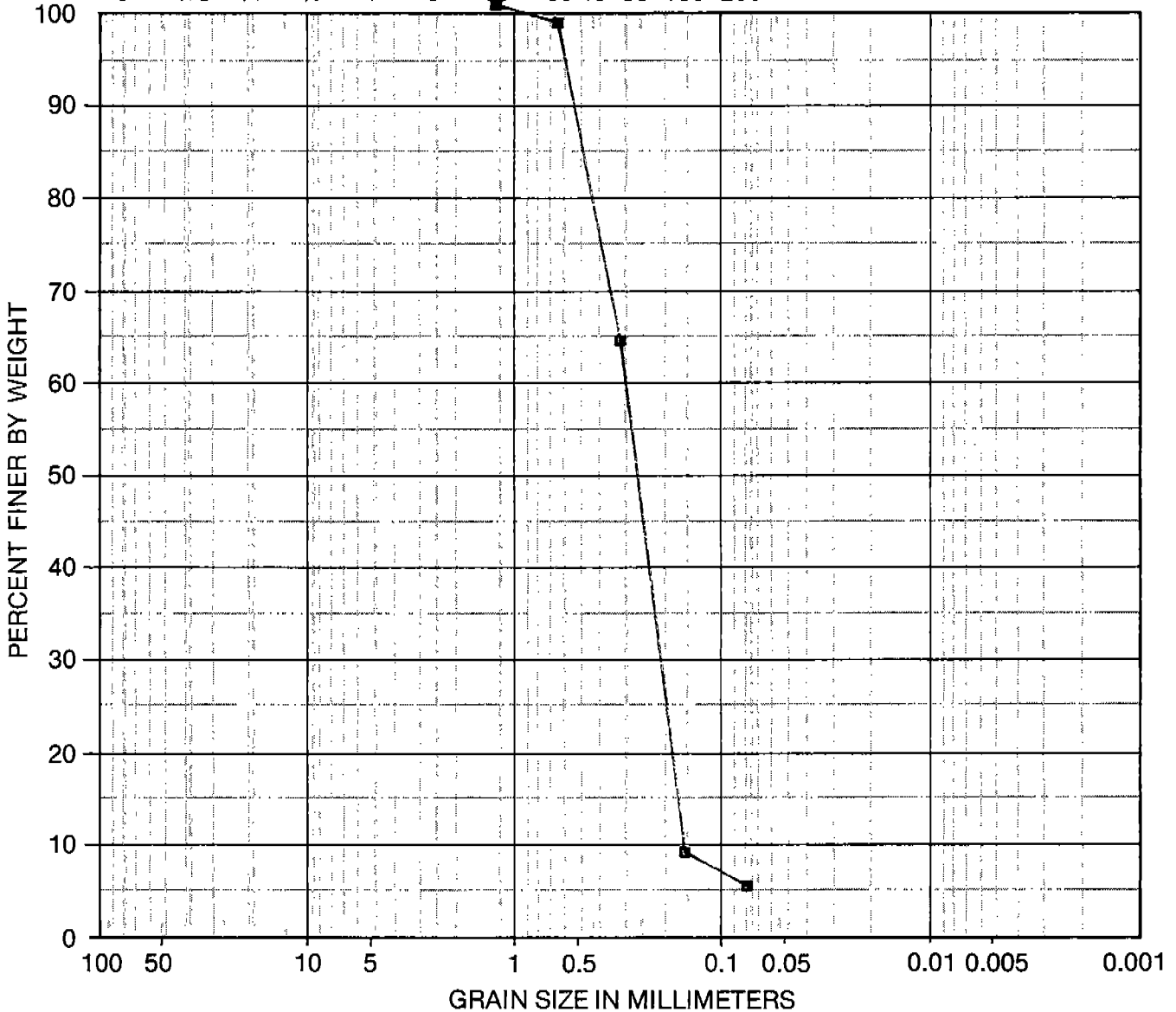

COBBLES	COARSE	FINE	COARSE	MEDIUM	FINE	SILT OR CLAY
	GRAVEL		SAND			

Symbol	Sample Source	Classification
■	SB-16-10 @ 15.5 FT	LIGHT BROWN SAND W/CLAY (SP-SC)



Harding Lawson Associates
Engineers, Geologists
& Geophysicists

Particle Size Analysis - Boring SB-16-10
Site Characterization
Site 16 - DOL Maintenance Yard, Pete's Pond
Fort Ord, California

PLATE

C10

U.S. Standard Sieve Size (in.) U.S. Standard Sieve Numbers Hydrometer

3 1½ ¾ ⅜ 4 8 16 30 40 50 100 200

Reference: ASTM D 422

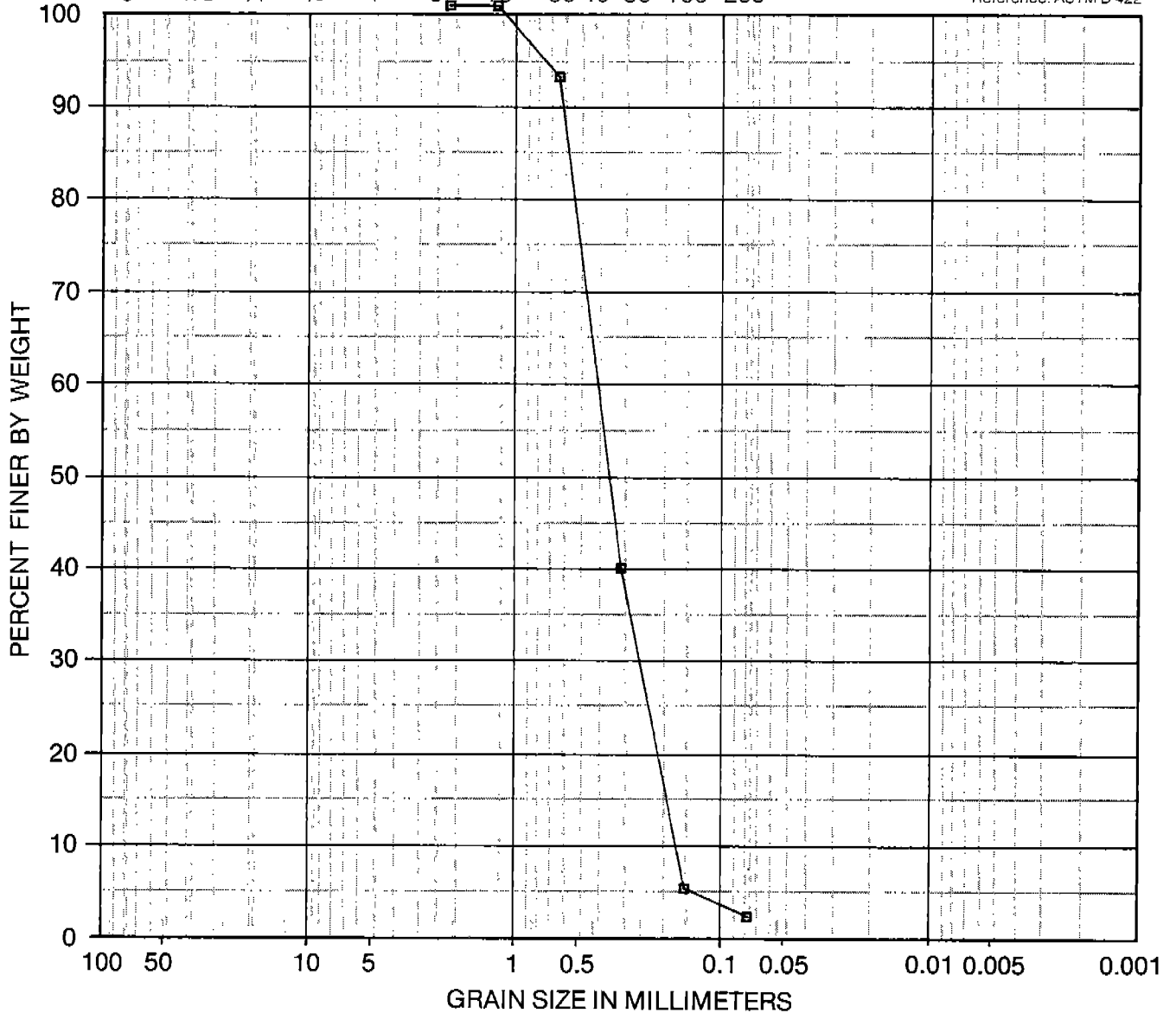

COBBLES	COARSE	FINE	COARSE	MEDIUM	FINE	SILT OR CLAY
	GRAVEL		SAND			

Symbol	Sample Source	Classification
■	SB-16-11 @ 15.5 FT	YELLOW-BROWN SAND (SP)



Harding Lawson Associates
 Engineers, Geologists
 & Geophysicists

Particle Size Analysis - Boring SB-16-11
 Site Characterization
 Site 16 - DOL Maintenance Yard, Pete's Pond
 Fort Ord, California

PLATE

C11

DRAWN

JOB NUMBER
07579.687.02

APPROVED

DATE
03-25-1992

REVISED

DATE

U.S. Standard Sieve Size (in.) → ← U.S. Standard Sieve Numbers → ← Hydrometer

3 1½ ¾ ⅜ 4 8 16 30 40 50 100 200

Reference: ASTM D 422

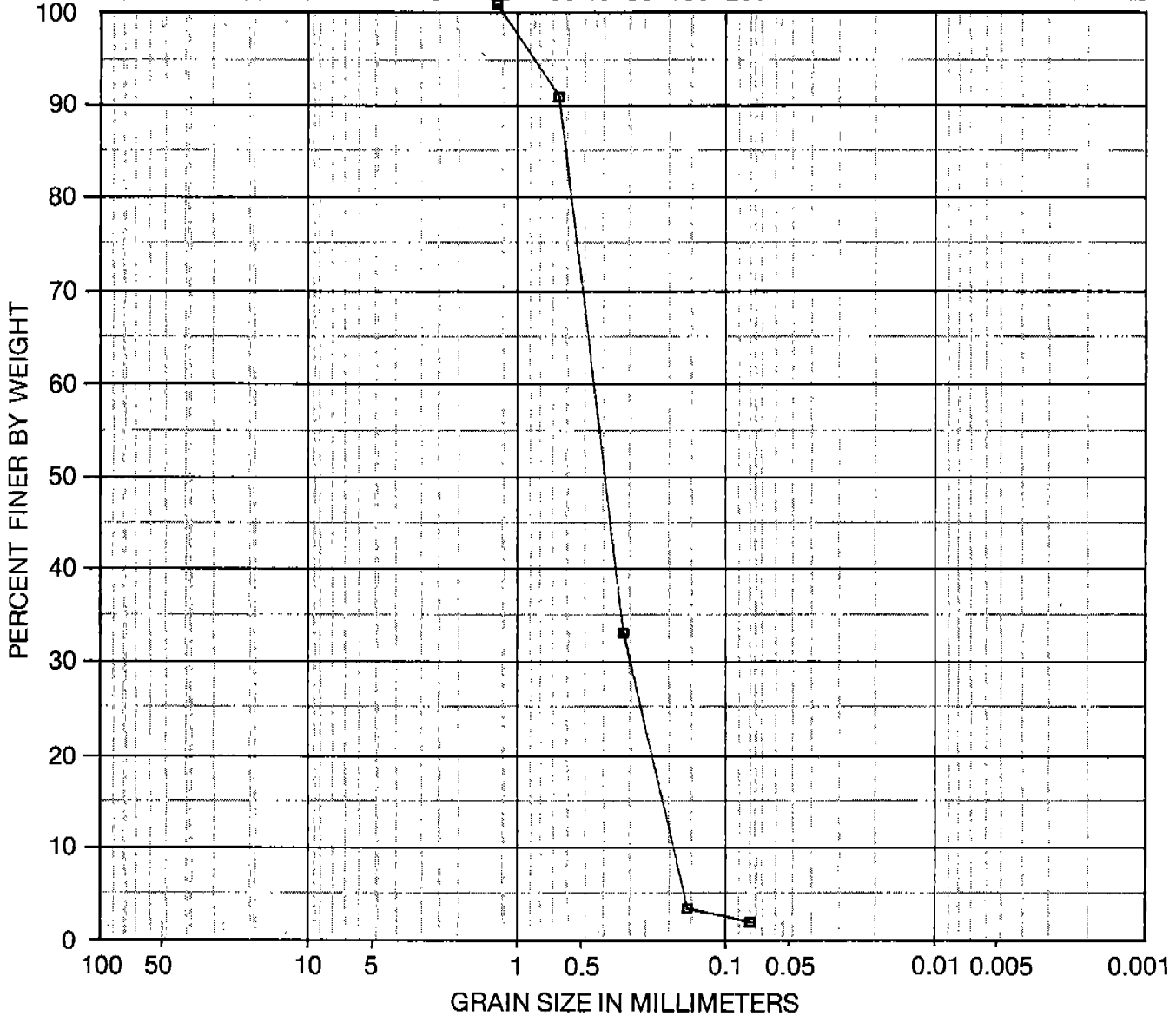

COBBLES	COARSE	FINE	COARSE	MEDIUM	FINE	SILT OR CLAY
	GRAVEL		SAND			

Symbol	Sample Source	Classification
■	SB-16-12 @ 10.0 FT	LIGHT BROWN SAND (SP)



Harding Lawson Associates
 Engineers, Geologists
 & Geophysicists

Particle Size Analysis - Boring SB-16-12
 Site Characterization
 Site 16 - DOL Maintenance Yard, Pete's Pond
 Fort Ord, California

PLATE

C12

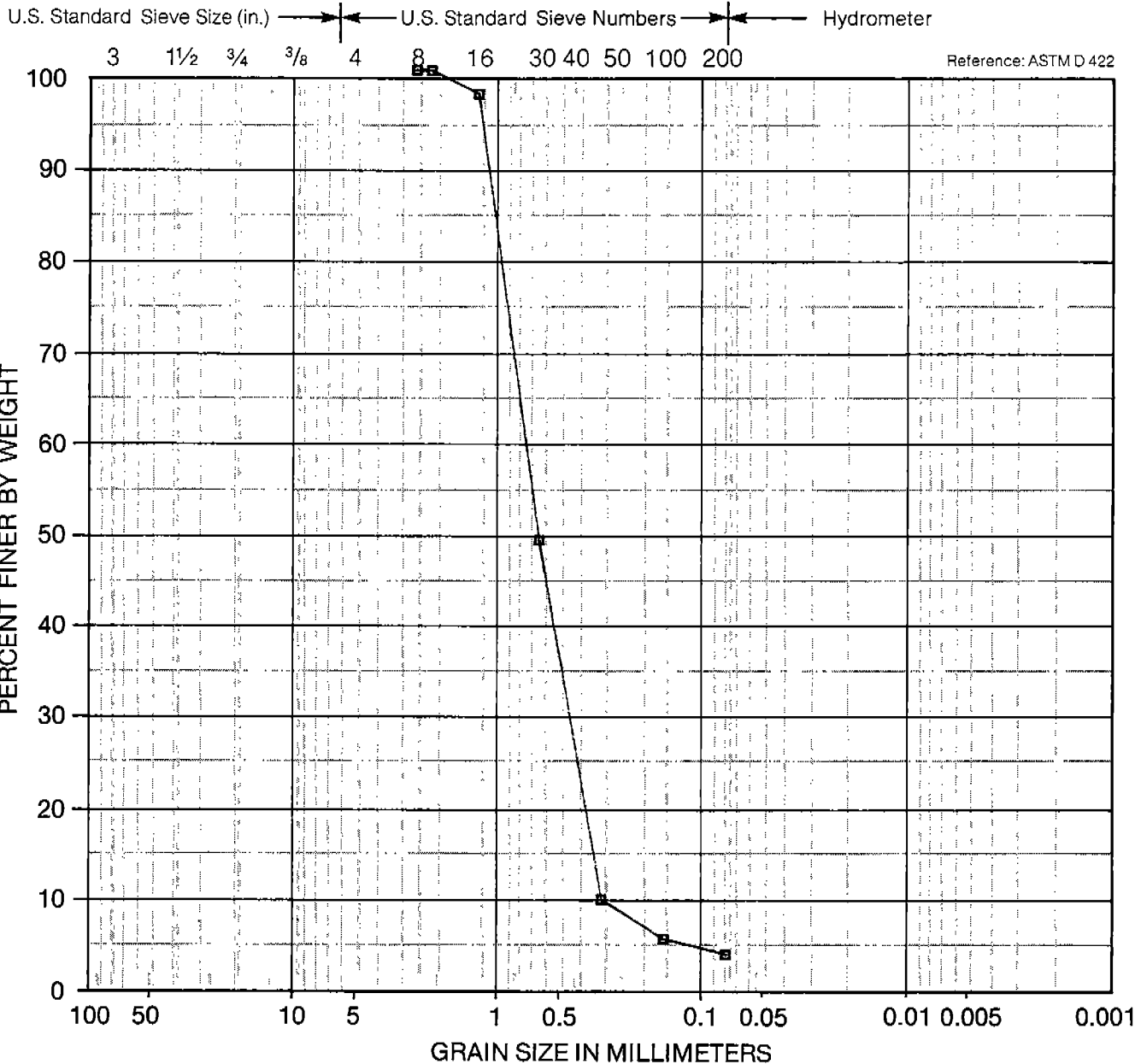

COBBLES	COARSE	FINE	COARSE	MEDIUM	FINE	SILT OR CLAY
	GRAVEL		SAND			

Symbol	Sample Source	Classification
□	MW-16-01 @ 105.5 FT	YELLOW-BROWN SAND (SP)



Harding Lawson Associates
 Engineers, Geologists
 & Geophysicists

Particle Size Analysis - Boring MW-16-01
 Site Characterization
 Site 16 - DOL Maintenance Yard, Pete's Pond
 Fort Ord, California

PLATE

C13

DRAWN

JOB NUMBER
07579.687.02

APPROVED

DATE
03-29-1992

REVISED

DATE

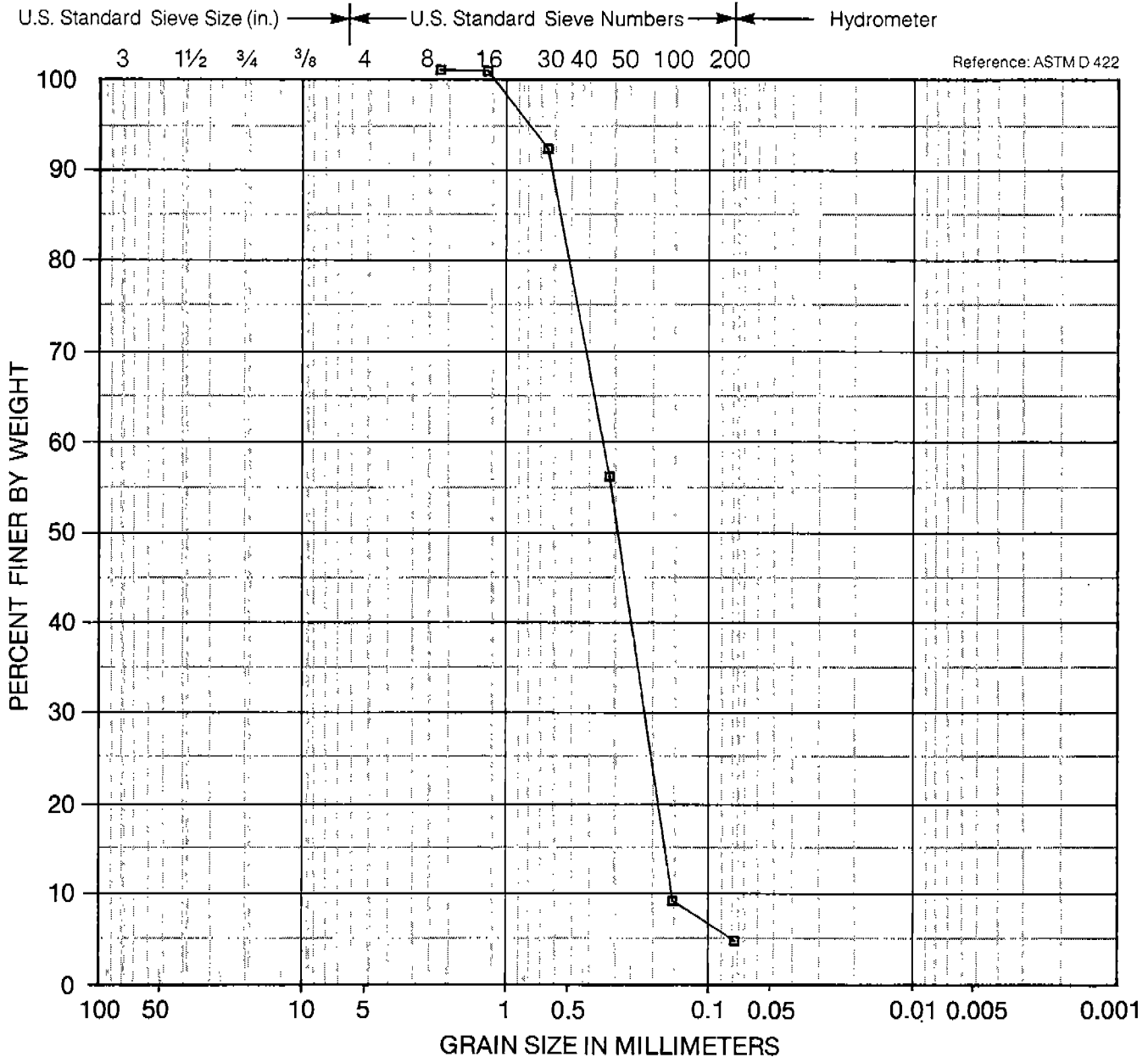

COBBLES	COARSE	FINE	COARSE	MEDIUM	FINE	SILT OR CLAY
	GRAVEL		SAND			

Symbol	Sample Source	Classification
■	SB-17-01 @ 31.0 FT	ORANGE-BROWN SAND (SP)



Harding Lawson Associates
 Engineers, Geologists
 & Geophysicists

Particle Size Analysis - Boring SB-17-01
 Site 17 - 1400 Block Motor Pool
 and Suspected Disposal Area
 Site Characterization
 Fort Ord, California

PLATE

C14

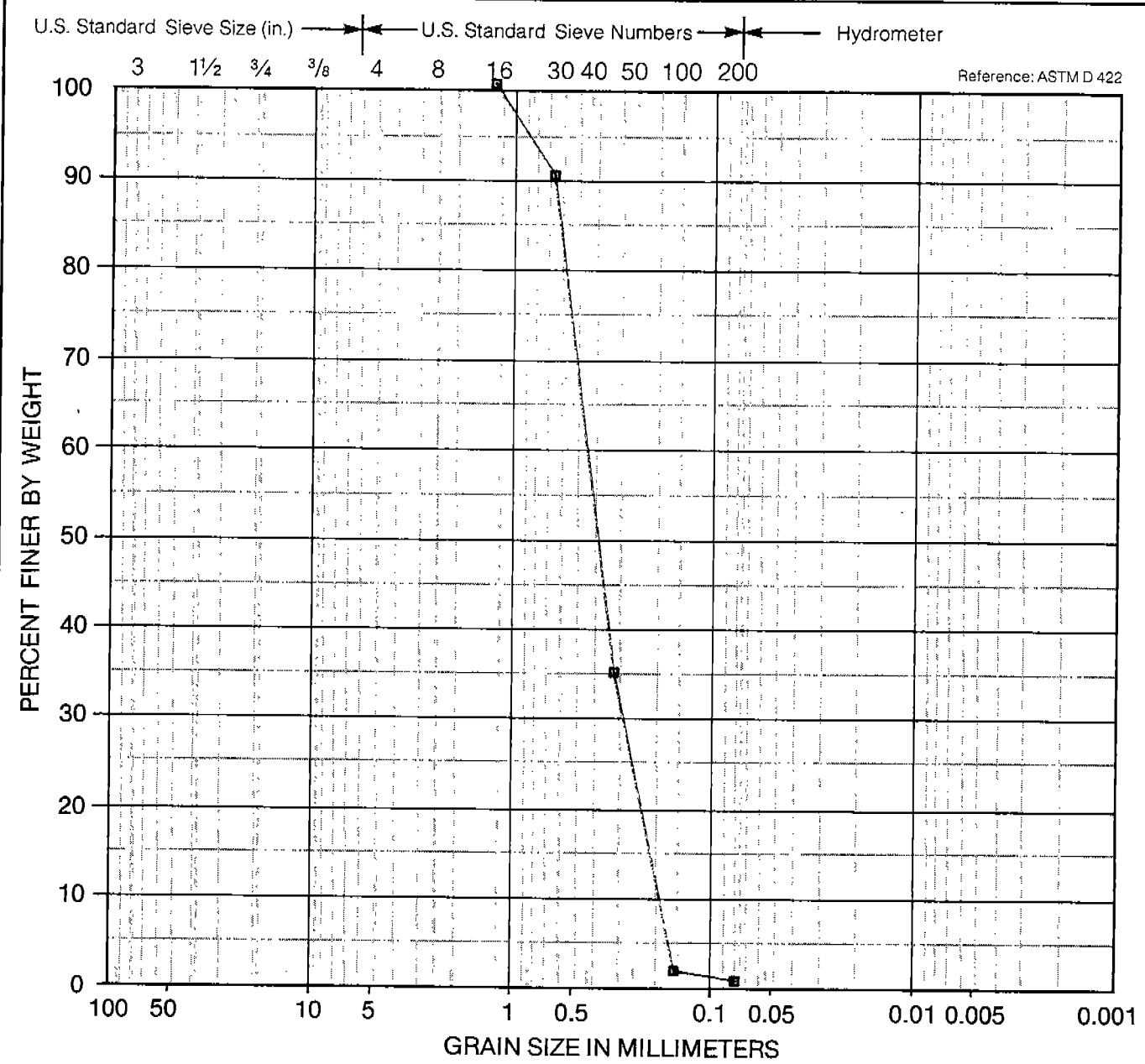

COBBLES	COARSE	FINE	COARSE	MEDIUM	FINE	SILT OR CLAY
	GRAVEL			SAND		

Symbol	Sample Source	Classification
■	SB-17-02 @ 16.0 FT	YELLOW-BROWN SAND (SP)



Harding Lawson Associates
 Engineers, Geologists
 & Geophysicists

Particle Size Analysis - Boring SB-17-02
 Site 17 - 1400 Block Motor Pool
 and Suspected Disposal Area
 Site Characterization
 Fort Ord, California

PLATE

C15

U.S. Standard Sieve Size (in.) U.S. Standard Sieve Numbers Hydrometer

Reference: ASTM D 422

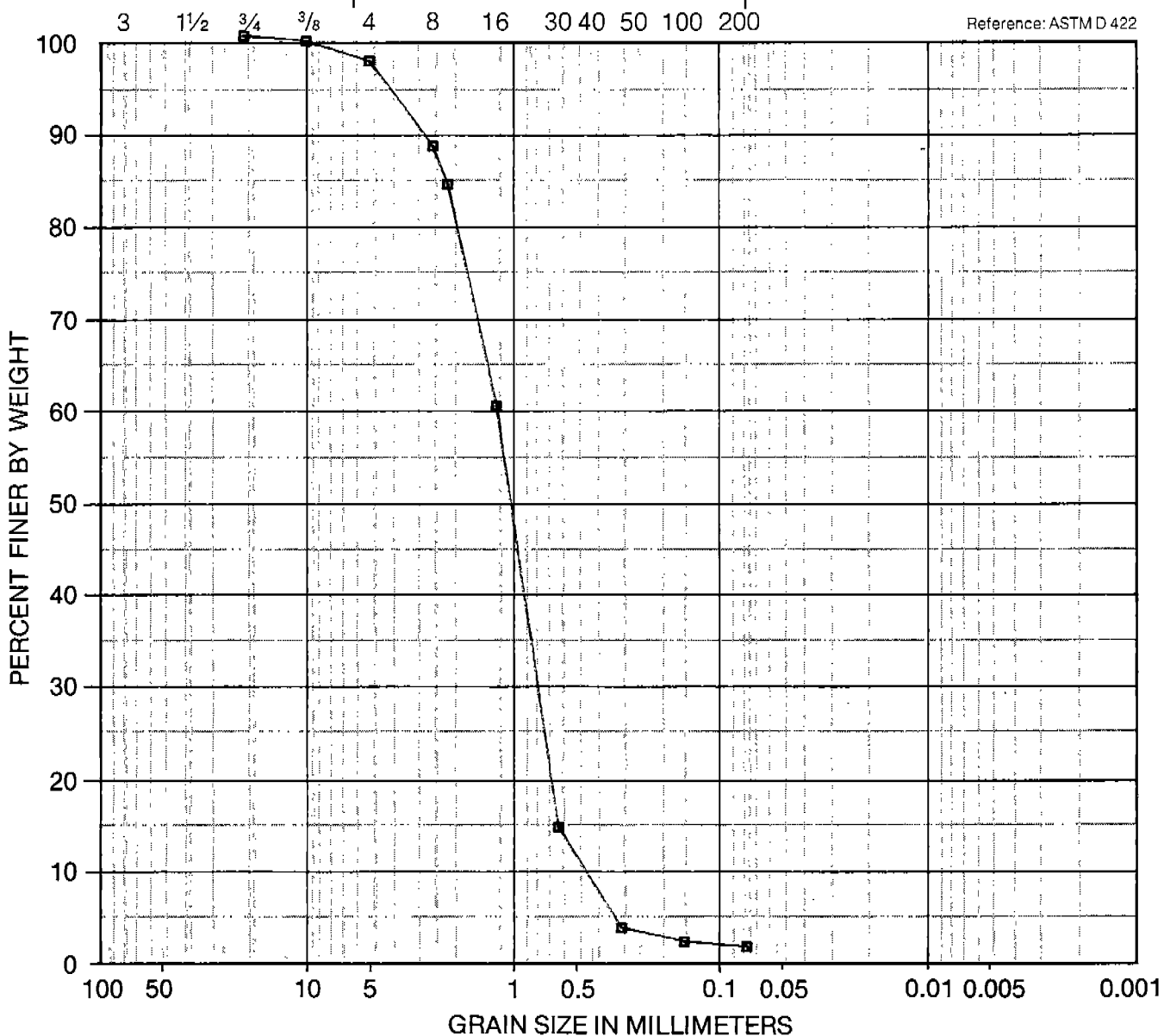

U.S. Standard Sieve Size (in.) U.S. Standard Sieve Numbers Hydrometer

3 1½ ¾ ⅜ 4 8 16 30 40 50 100 200

Reference: ASTM D 422

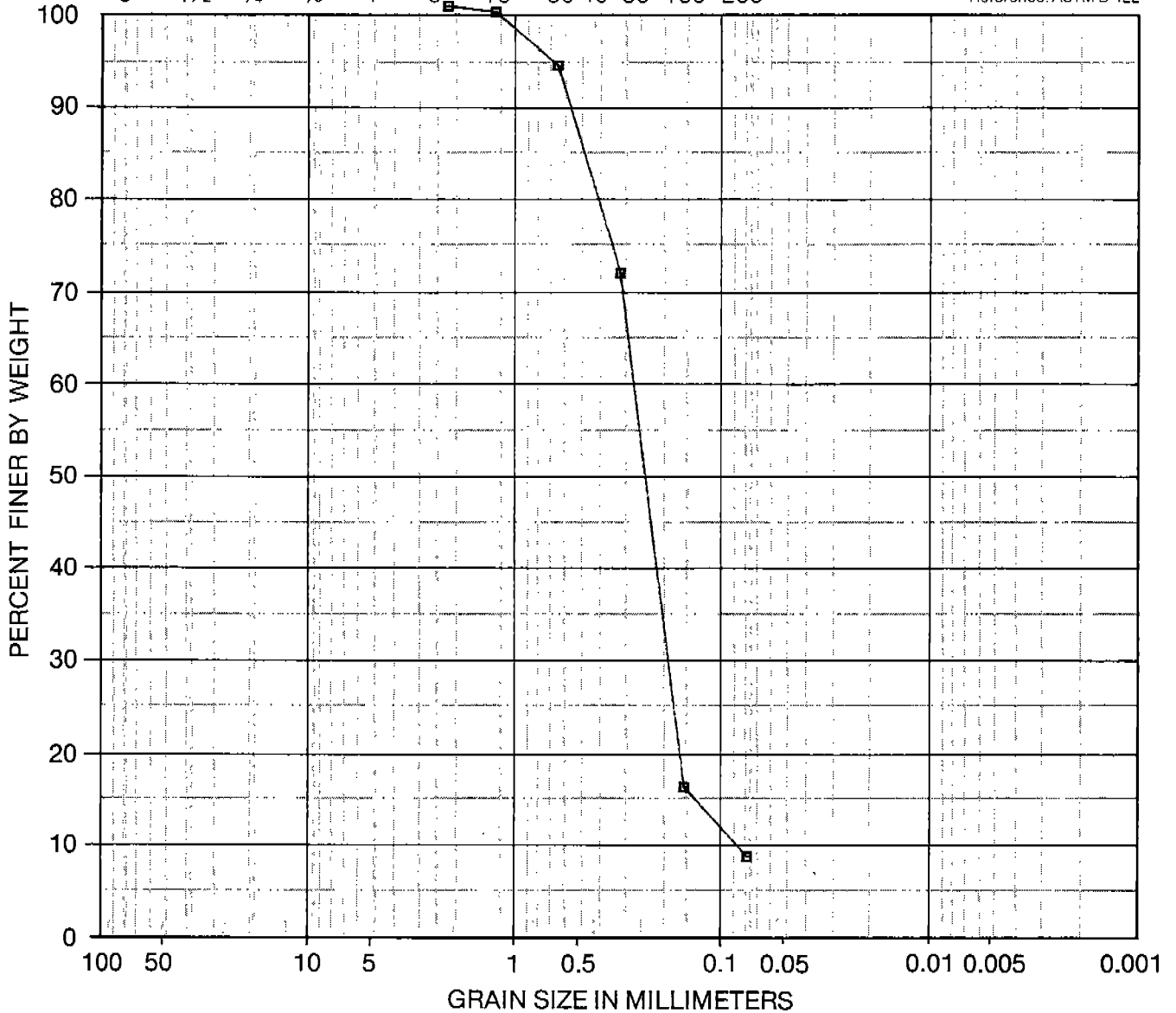

COBBLES	COARSE	FINE	COARSE	MEDIUM	FINE	SILT OR CLAY
	GRAVEL		SAND			

Symbol	Sample Source	Classification
■	MW-17-02 @ 180.0 FT	BROWN SAND W/CLAY (SP-SC)



Harding Lawson Associates
Engineers, Geologists
& Geophysicists

Particle Size Analysis - Boring MW-17-02
Site 17 - 1400 Block Motor Pool
and Suspected Disposal Area
Site Characterization
Fort Ord, California

PLATE

C17

DRAWN

JOB NUMBER
07579.694.02

APPROVED
ETH

DATE
03-26-1992

REVISED

DATE



SOLEA
TESTING
GROUP

Transmittal/Memorandum

To: **Harding Lawson Associates**
7655 Redwood Blvd., P.O. Box 578
Novato, CA 94948

Attn: Brent Dostert

From: Ms. Farideh Faraji, Technical Director
Date: November 18, 1993
Subject: Laboratory Test Results; Fort Ord Site 16, HLA #23366.01724
STG No.: HLA.002
LRN: 4376

Remarks: Enclosed are the final test results for the subject project. Samples were submitted to our Laboratory November 8, 1993. These tests have been performed in general accordance with accepted standards and checked with STG's Quality Assurance Plan. This transmittal includes the following test(s):

Item	Description	Quantity
1	Moisture Content & Dry Density	2
2	Sieve Analysis to #200 Sieve	2
3	Organic Content	2

Untested samples, portions of tested samples, when available, and sample tubes will be held for a period of 8 weeks. Samples and tubes will be discarded at that time unless other arrangements are made. Sample storage fees will be charged for storage periods greater than 8 weeks. STG does not store contaminated samples and by-products produced from testing. These will be returned to you.

If you have any questions, please call me at (510) 682-7005. Thank you.

Ms. Farideh Faraji, Technical Director

Thomas Davise, CEO

cc:

SOLEA TESTING GROUP



Statement of Additions and Omissions

Harding Lawson Associates
7655 Redwood Blvd., P.O. Box 578
Novato, CA 94948

Laboratory Test Results; Fort Ord Site 16, HLA #23366.01724

November 18, 1993

STG Client No.: HLA.002

1. Sample SB-16-18, 9342BO16077F, @ 4.0' the air permeability was impervious. No replacement sample was provided.
-
-



LABORATORY TESTING PROGRAM

Sample Receipt Record

LRN
4376

CLIENT NAME Harding Lawson Ass	CONTRACT NO.	SOLEA CLIENT NUMBER
CLIENT PROJECT Fort Ord Site 16	REPORT ADDRESS 7655 Redwood Blvd. P.O. Box 57B	DATE VERBAL RESULTS DUE
CLIENT PROJECT NO. 23366-01724	CITY Novato Calif 94948	DATE FINAL REPORT DUE
CONTACT / REPORT TO Rick McCartney	INVOICE ADDRESS Same as above	RECEIVED BY / DATE
TESTS ASSIGNED BY David Browne	PHONE NUMBER (415) 892-0821	HAZARD I.D.
SAMPLES RELINQUISHED BY Rich - CC - Civil	FAX NUMBER	SAMPLE TYPE CODE <small>ST-shelby, BT-brass, SS-stainless, BK-bulk, BG-baggie, J-yr</small>

HOLE NO.	SAMPLE I.D.	DEPTH (FT)	SAMPLE TYPE	SAMPLE CONDITION	CONTAMINATED	SAMPLE RECEIVED	010	011	025	030	040	042	043	100	120	150	167	175	200	211	220	222	REMARKS
							MOISTURE CONTENT	MOISTURE AND DENSITY	SPECIFIC GRAVITY	ATTERBERG LIMIT, 3-PT	SIEVE ANALYSIS TO #200	PERCENT PASSING #200	HYDROMETER ANALYSIS	ORGANIC Content	COMPACTION (MODIFIED)	R-VALUE	CONSOLIDATION	TRIAxIAL PERMEABILITY*	AIR PERMEABILITY	UNCONFINED COMPRESSION	DIRECT SHEAR (UU)*	TRIAxIAL SHEAR (UU)*	
1	SB-16-16 93423016																						
2	SB-16-16 077 F	3																					
3	SB-16-16 078 F	4																					
4	SB-16-16 079 F	4.5																					
5	SB-16-18 086 F	2.0																					
6	SB-16-18 087 F	2.5																					
7	SB-16-18 090 F	4.0																					
8	SB-16-18 091 F	5.0																					
9																							
10																							
11																							
12																							
13																							
14																							
15																							
TALLY																							

SPECIAL INSTRUCTIONS	PAGE
	STORAGE LOCATION
	LEGEND
	NOTES
	TEST ASSIGNED
	TEST PREPARED
	TEST COMPLETED
	TEST COMPUTERIZED



Transmittal/Memorandum

To: Harding Lawson Associates
105 Digital Drive
Novato, CA 94949

Attn: Rick McCartney

From: Ms. Farideh Faraji, Technical Director
Date: April 7, 1994
Subject: Laboratory Test Results; Fort Ord, Site 16/17
STG No.: HLA.002
LRN: 4469

Remarks: Enclosed are the final test results for the subject project. Samples were submitted to our Laboratory March 23, 1994. These tests have been performed in general accordance with accepted standards and checked with STG's Quality Assurance Plan. This transmittal includes the following test(s):

Item	Description	Quantity
1	Moisture Content & Dry Density	9
2	Porosity	4
3	Atterberg Limit Non-Plastic	13
4	Sieve Analysis to #200 Sieve	11
5	Organic Content	13
6	Compaction (Modified) 4"	4
7	Swell Consolidation-Method A	4
8	Fixed-Wall Permeability-Falling Head	5

Untested samples, portions of tested samples, when available, and sample tubes will be held for a period of 8 weeks. Samples and tubes will be discarded at that time unless other arrangements are made. Sample storage fees will be charged for storage periods greater than 8 weeks. STG does not store contaminated samples and by-products produced from testing. These will be returned to you.

If you have any questions, please call me at (510) 682-7005. Thank you.

A handwritten signature in cursive script that reads "Farideh Faraji".

Ms. Farideh Faraji, Technical Director

cc:



Transmittal/Memorandum

To: **Harding Lawson Associates**
105 Digital Drive
Novato, CA 94949

Attn: Rick McCartney

From: Ms. Farideh Faraji, Technical Director
Date: April 8, 1994
Subject: Laboratory Test Results; Fort Ord, Site 16/17
STG No.: HLA.002
LRN: 4469

Remarks: Enclosed are the final test results for the subject project. Samples were submitted to our Laboratory March.23, 1994. These tests have been performed in general accordance with accepted standards and checked with STG's Quality Assurance Plan. This transmittal includes the following test(s):

Item	Description	Quantity
1	R-Value and Expansion Pressure	1

Untested samples, portions of tested samples, when available, and sample tubes will be held for a period of 8 weeks. Samples and tubes will be discarded at that time unless other arrangements are made. Sample storage fees will be charged for storage periods greater than 8 weeks. STG does not store contaminated samples and by-products produced from testing. These will be returned to you.

If you have any questions, please call me at (510) 682-7005. Thank you.

A handwritten signature in cursive script that reads "Farideh Faraji".

Ms. Farideh Faraji, Technical Director

cc:

SOLEA TESTING GROUP

Statement of Additions and Omissions

**Harding Lawson Associates
105 Digital Dr.
Novato, CA 94949**

Laboratory Test Results: Ford Ord Site 16/17

April 8, 1994

STG Client No. HLA.002

- 1. Boring SB-17-11 @ 4.5 - 5.0 was too disturbed - permeability test was omitted.**
- 2. Borings SB-16-26 @ 18 and SB-16-26 @ 2.5 were too disturbed - consolidation test was omitted.**
- 3. Specific gravity test was run on SB-16-26 @ 17.5, SB-16-26 @ 2.5, SB-17-08 @ 30.5 and SB-16-24 @ 18.5 instead of air permeability.**



Harding Lawson Associates
Engineering
and
Environmental Services

SHEET 1 OF 6

JOB NO _____

DATE 3/29

COMPUTED BY MSG

CHECKED BY _____

PROJECT PORT ORD RF SAMPLE
SUBJECT _____

3/29/94

Farideh
Solea Testing Group
Concord, CA

Because air permeability tests are unavailable for recent soil samples sent to your laboratory, please run specific gravity tests for soil samples which requested the air permeability tests.

Sincerely,
Mark Grothe

SOLEA

LABORATORY TESTING PROGRAM

LRW

Sample Receipt Record

CLIENT NAME <i>Harding Lawson</i>	CONTRACT NO.	SOLEA CLIENT NUMBER
CLIENT PROJECT <i>Fort Ord - Site 16/17</i>	REPORT ADDRESS	DATE OF LAB RESULTS DUE
	CITY <i>Novato</i>	DATE OF FINAL REPORT DUE
CLIENT PROJECT NO. <i>23366 01724</i>	INVOICE ADDRESS	RECEIVED BY / DATE
CONTACT / REPORT TO <i>Rick McLarney</i>	CITY	HAZAR. I.D.
TESTS ASSIGNED BY <i>Rick McLarney</i>	PHONE NUMBER	SEE LABORATORY HEALTH AND SAFETY PLAN
SAMPLES RELINQUISHED BY <i>Rick McLarney</i>	FAX NUMBER <i>415-884-3300</i>	SAMPL. TYPE CODE <i>2 - shcher, BT-brass, SS-stainless, BK-bulk, BG-baggie, J-jar</i>

HOLE NO.	SAMPLE I.D.	DEPTH (FT.)	SAMPLE TYPE	SAMPLE CONDITION	CONTAMINATED	SAMPLE RECEIVED	010	011	025	030	040	042	043	100	120	150	167	176	200	211	220	222	CONFINING PRESSURE (PSI)	REMARKS	
SPECIAL INSTRUCTIONS																									
11	SB-16-22	2-4ft	S	P																					Segal
12	SB-16-24	2-4ft	S	P																					Segal
13	SB-16-26	2-4ft	S	P																					Segal
14	SB-17-4	140F 4.5-16	S	G												X									Fill
15	SB-17-11	140F 4.5-12	S	C							XX														Fill
16	SB-17-4	140F 4.5-11	S	C																					Fill
17	SB-17-4	139F 4.5-5	S	G																					cover
18	SB-17-11	139F 5.5-6	S	C																					cover
18	SB-17-11	139F 4-4.5	S	C																					cover
19	SB-17-11	139F 1.5-2	S	C							XX														cover
11	SB-17-11	142F 20.5-21	S	G																					native
12	SB-17-11	142F 22.5-23	S	G							XX														native
13	SB-17-11	142F 23-23.5	S	G																					Native
14	SB-17-11	1.5-4	S	P												XX									Segal
15																									

TALLY	PAGE
SPECIAL INSTRUCTIONS	STORAGE LOCATION
(1) Consolidation - flood at 100 psf after initial settling	LEGEND
	NOTES
	TEST ASSIGNED
	TEST PREPARED
	TEST COMPLETED
	TEST COMPUTERIZED

SOLEA
SOLEA TESTING GROUP

LABORATORY TESTING PROGRAM
Sample Receipt Record

LRN

CLIENT NAME <i>Harding Lawson Associates</i>	CONTRACT NO.	SOLEA CLIENT NUMBER
CLIENT PROJECT <i>Fort Ord Site 16/17</i>	REPORT ADDRESS	DATE PERIOD RESULTS DUE
CLIENT PROJECT NO. <i>23366 01724</i>	CITY <i>Norcho</i>	DATE FINAL REPORT DUE
CONTACT / REPORT TO <i>Rich McCarty</i>	INVOICE ADDRESS	RECEIVED BY / DATE
TESTS ASSIGNED BY <i>Rich McCarty</i>	PHONE NUMBER	SEE LABORATORY HEALTH AND SAFETY PLAN
SAMPLES RELINQUISHED BY	FAX NUMBER <i>415-884-3300</i>	SAMPLE TYPE CODE <small>*T=heavy, ET=extra, SS=standard, BK=bulk, EG=egg, J=jet</small>

HOLE NO.	SAMPLE I.D.	DEPTH (FT)	SAMPLE TYPE	SAMPLE CONDITION	CONTAMINATED	SAMPLE RECEIVED	013	011	025	030	040	042	043	100	120	150	167	175	200	211	220	222	REMARKS		
							MOISTURE CONTENT	MOISTURE AND DENSITY	SPECIFIC GRAVITY	ATTERBERG LIMIT, 3 PT	SIEVE ANALYSIS TO #200	PERCENT PASSING #200	HYDROMETER ANALYSIS	Organic Content	COMPACTION (MODIFIED)	N-VALUE	CONSOLIDATION (L)	TRIAxIAL PERMEABILITY*	AIR PERMEABILITY	UNCONFINED COMPRESSION	DIRECT SHEAR (UU)*	TRIAxIAL SHEAR (UU)*	TRIAxIAL SHEAR (CU)*	*CONFINING PRESSURE (PSI)	
1	SB-17-07	9410Y017127F	25-25.5	S	P		X																	active	
2	SB-17-07	9410Y017128F	21-21.5	S	G														X						active
3	SB-17-07	"	20-20.5	S	P				X	X															active
4	SB-17-07	9410Y017122F	4-4.5	S	G												X								fill
5	SB-17-07	"	10.5-11	S	P		X																		fill
6	SA-17-07	9410Y017122F	4.5-5	S	G				X	X															fill
7	SB-16-26	9409Y016024F	17.5-18	S	P		X	X					X												active
8	SB-16-26	"	16.5-17	S	-				X	X															active
9	SB-16-26	"	16-16.5	S	G														X						active
10	SB-16-26	"	18-18.5	S	G												X								active
11	SB-16-26	9409Y116020F	2.5-4	S	P		X	X					X												cover
12	SB-16-26	"	2.5-4	S	P				X	X															cover
13	SB-16-26	"	2.5-4	S	P												X								cover
14	SB-17-08	9410Y017044F	15-15.5	S	P		X																		fill
15	SB-17-08	"	15.5-16	S	G				X	X															fill

TALLY	PAGE
SPECIAL INSTRUCTIONS	STORAGE LOCATION
(1) Consolidation - flood at 100 pcf after initial settling	LEGEND
	NOTES
	TEST ASSIGNED
	TEST PREPARED
	TEST COMPLETED
	TEST COMPUTERIZED

SOLEA

LABORATORY TESTING PROGRAM

LRN

Sample Receipt Record

CLIENT NAME <i>Herding Lawson Associates</i>	CONTRACT NO.	SOLEA CLIENT NUMBER
CLIENT PROJECT <i>Fort Ord Site 16/17</i>	REPORT ADDRESS	DATE VERBAL RESULTS DUE
	CITY <i>Novato</i>	DATE FINAL REPORT DUE
CLIENT PROJECT NO. <i>23366 01724</i>	INVOICE ADDRESS	RECEIVED BY / DATE
CONTACT / REPORT TO <i>Rick McCartney</i>	CITY	HAZAR. I.D.
TESTS ASSIGNED BY <i>Rick McCartney</i>	PHONE NUMBER	SEE LABORATORY HEALTH AND SAFETY PLAN
SAMPLES RELINQUISHED BY	FAX NUMBER <i>415-884-3300</i>	SAMPL. TYPE CODE <i>S=shells, B=bricks, SS=stairs, BK=bulk, BG=bagged, J=jar</i>

HOLE NO.	SAMPLE I.D.	DEPTH (FT)	SAMPLE TYPE	SAMPLE CONDITION	CONTAMINATED	SAMPLE RECEIVED	010	011	022	030	040	042	043	100	120	150	107	176	200	211	220	222	REMARKS
							MOISTURE CONTENT	MOISTURE AND DENSITY	SPECIFIC GRAVITY	ATTENBERG LIMIT, 3-PT	SIEN ANALYSIS TO #200	PERCENT PASSING #200	HYDROMETER ANALYSIS	Original Compaction	COMPACTION (MODIFIED)	R-VALUE	CONSOLIDATION (C)	TRIAxIAL PERMEABILITY	AIR PERMEABILITY	UNCONFINED COMPRESSION	DIRECT SHEAR (UU)	TRIAxIAL SHEAR (UU)	
1	SB-17-08	94101017053R	35.5-36	S	P					X	X												active
2	SB-17-08	94101017051F	30.5-31	S	P		X	X					X										active
3	SB-17-08	"	31.5-32	S	G																		active
4	SB-17-08	94101017057F	42.5-43	S	P											X							active
5	SB-16-24	94096016101F	3-3.5	S	-		X	X															fill, no casing
6	SB-16-24	"	3-3.5	S	-					X	X												fill
7	SB-16-24	94096016104F	18-18.5	S	G																		active
8	SB-16-24	"	17.5-18	S	P					X	X												active
8	SB-16-24	"	18.5-19	S	G		X	X					X										active
10																							
11																							
12																							
13																							
14																							
15																							

TALLY	
SPECIAL INSTRUCTIONS	PAGE
(1) Consolidation - flood at 100 psf after initial settling	STORAGE LOCATION
	LEGEND
	NOTES
	TEST ASSIGNED
	TEST PREPARED
	TEST COMPLETED
	TEST COMPUTERIZED

Sample No.	Boring No.	Depth (ft.)	Sample Description	Group Symbol	Molsture Content,%	Dry Density,pc	Specific Gravity	Void Ratio	Porosity %	Saturation %
	SB-17-11	10.5-11	Dark Brown Silty Sand	SM	6.5	105.6				
	SB-17-11	5.5-6	Light Brown Sand	SP	3.7	106.8				
	SB-17-11	23-23.5	Light Brown Sand	SP	2.9	89.9				
	SB-17-07	25-25.5	Light Brown Sand	SP	3.5	101.8				
	SB-17-07	10.5-11	Brown sand W/Silt	SP-SM	5.3	87.0				
	SB-16-26	17.5-18	Yellow Brown Sand W/Silt	SP-SM	2.4	100.5	2.61	0.621	38.3	10.1
	SB-16-26	2.5-4	Dark Brown Silty Sand	SM	8.6	93.2	2.61	0.748	42.8	30.2
	SB-17-08	15-15.5	Dark Brown Silty Sand	SM	8.4	86.0				
	SB-17-08	30.5-31	Yellow Brown Silty Sand	SM	9.0	104.7	2.64	0.574	36.5	41.5
	SB-16-24	3.5-4	Dark Brown Silty Sand	SM	10.3	79.0				
	SB-16-24	18.5-19	Yellow Brown Silty Sand	SM	3.3	97.7	2.65	0.694	41.0	12.8
	SB-31-23	3.5-4	Yellow-Brown Silty Sand	SM	5.8	84.3				
	SB-31-31	3.5-4	Dark Brown Silty Sand	SM	8.8	81.0				



LABORATORY SUMMARY REPORT

HLA-Fort Ord, Site 16/17

Sample No.	Boring No.	Depth (ft.)	Sample Description	Group Symbol	Moisture Content, %	Dry Density, pcf	Organic Content
9342B016077F	SB-16-16	3			7.1	115.2	
9342B016078F	SB-16-16	4	Brown Silty Sand	SM			
9342B016079F	SB-16-16	4.5	Dark Brown Silty Sand	SM			8.7
9342B016086F	SB-16-18	2	Dark Brown Sand w/Silt	SP-SM			4.4
9342B016087F	SB-16-18	2.5			4.8	110.6	
9342B016090F	SB-16-18	4					
9342B016091F	SB-16-18	5	Yellow Brown Sand w/Silt	SP-SM			



LABORATORY SUMMARY REPORT
HLA-Fort Ord Site 16, #23366.01724

DRAWN
CLM

DATE
11/18/93

PROJECT
HLA.002

LRN
4376

APPROVED
FF

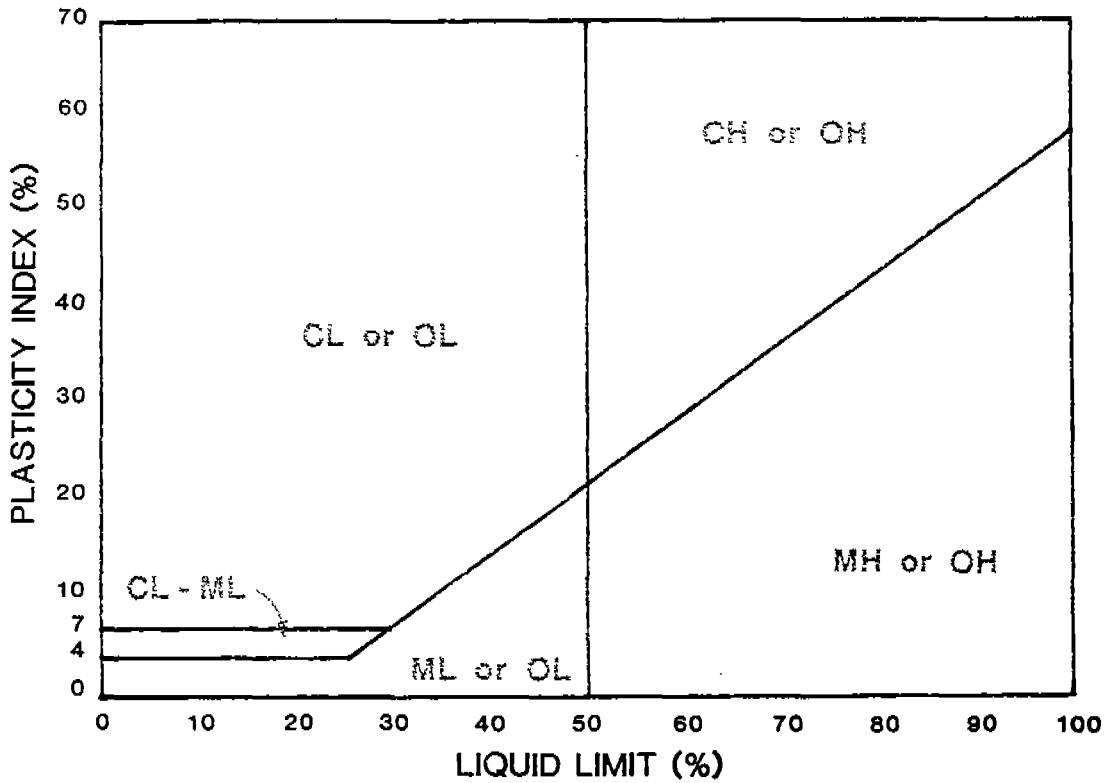

SYMBOL	BORING NUMBER	DEPTH (feet)	CLASSIFICATION	LL (%)	PL (%)	PI (%)	MOISTURE CONTENT (%)
☐	SB-16 -24	3.0	DARK BROWN SAND W/SILT (SP-SM)	NP	NP	NP	
△	SB-16 -24	17.5	BROWN SAND (SP)	NP	NP	NP	
▽	SB-16 -26	2.5	LIGHT BROWN SILTY SAND (SM)	NP	NP	NP	
◇	SB-16 -26	16.5	LIGHT BROWN SAND (SP)	NP	NP	NP	
+	SB-17 -07	4.5	LIGHT BROWN SAND (SP)	NP	NP	NP	
⊙	SB-17 -07	20.0	LIGHT BROWN SAND (SP)	NP	NP	NP	
X	SB-17 -08	15.5	BROWN SAND (SP)	NP	NP	NP	

Plasticity Chart

PLATE



SOLEA TESTING GROUP

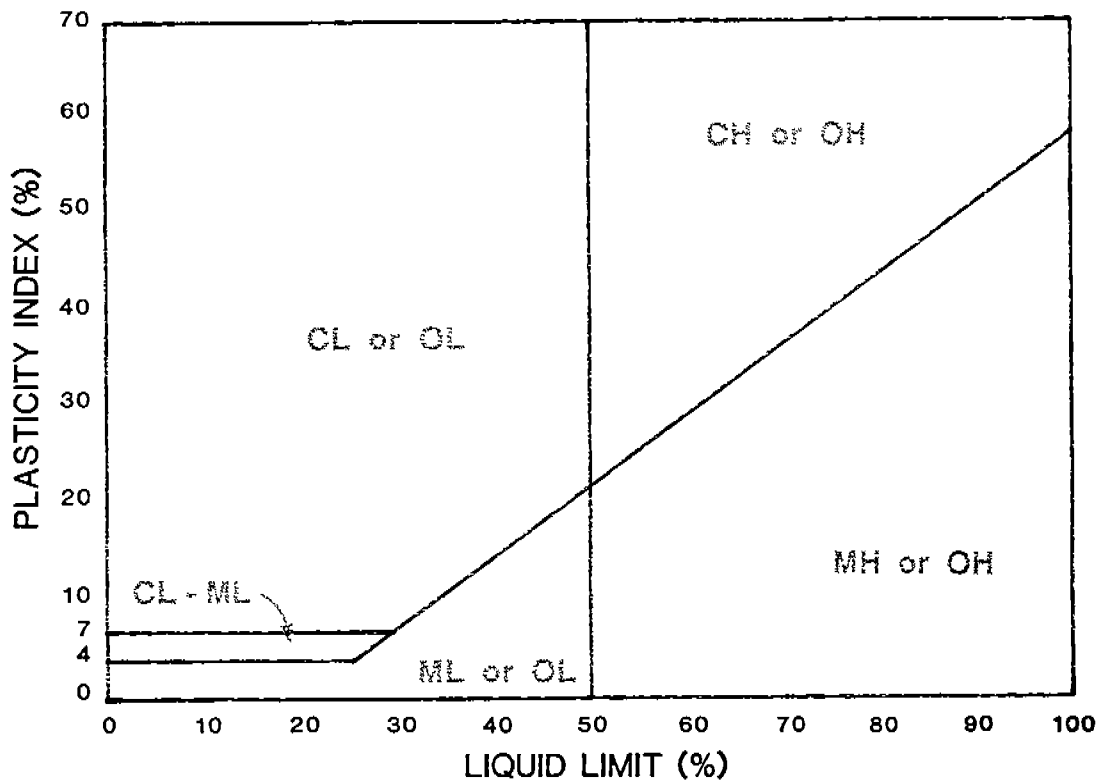

SYMBOL	BORING NUMBER	DEPTH (feet)	CLASSIFICATION	LL (%)	PL (%)	PI (%)	MOISTURE CONTENT (%)
□	SB-17-08	35.5	BROWN SAND (SP)	NP	NP	NP	
△	SB-17-11	1.5	YELLOW BROWN SAND W/SILT (SW-SM)	NP	NP	NP	
▽	SB-17-11	11.5	BROWN SAND W/SILT (SP-SM)	NP	NP	NP	
◇	SB-17-11	22.5	LIGHT BROWN SAND (SP)	NP	NP	NP	
+	SB-31-23	3.5	DARK BROWN SILTY SAND (SM)	NP	NP	NP	
⊙	SB-31-31	3.5	YELLOW-BROWN SILTY SAND (SM)	NP	NP	NP	

Plasticity Chart

PLATE

SOLEA

SOLEA TESTING GROUP

DRAWN

JOB NUMBER

23366-4469

APPROVED

FF

DATE

04-07-1994

REVISED

DATE

Particle Size Analysis
Sieve Method
HLA Laboratory Analysis Routines Ver 3.0

Project Name: HLA-FORT ORD
Project Number: HLA.2-4376

Test Date: 11-16-1993
Location: SB16-16 @ 4.0

Total Sample Weight (g): 744.4
Percent Passing No. 10 Sieve : 0.0
Representative Sample Weight (g): ----

PI Results (used in determining fines classification)

Liquid Limit: --- Plasticity Index: ---

Soil Composition (%)	Particle Diameter (mm):
Gravel : 0.0	@ 60% Passing : 0.3660
Sand : 84.4	@ 30% Passing : 0.1915
Fines : 15.6	@ 10% Passing : 0.0338

Coefficient of Uniformity: 1.08E 1

Coefficient of Curvature: 2.96E 0

Soil Classification: BROWN SILTY SAND (SM*)

Frost Classification: --

Data Entry By: CLM

File #: 613

Particle Size Analysis
Sieve Method
HLA Laboratory Analysis Routines Ver 3.0

Project : HLA-FORT ORD ID : HLA.2-4376 Test Date : 11-16-1993
Data Entry By : CLM Location : SB16-16 @ 4.0 Data File : TEST0613

Sieve Name	Sieve Size (mm)	Cum. Weight Retained (g)	Percent of Total Weight Passing
5.000 in	125.000	0.0	100.0
3.000 in	75.000	0.0	100.0
1.500 in	37.500	0.0	100.0
3/4 in	19.000	0.0	100.0
3/8 in	9.500	0.0	100.0
No. 4	4.750	0.0	100.0
No. 8	2.360	0.3	100.0
No. 10	2.000	0.6	99.9
No. 16	1.180	1.4	99.8
No. 30	0.600	69.0	90.7
No. 50	0.300	389.7	47.6
No. 100	0.150	592.6	20.4
No. 200	0.075	628.6	15.6

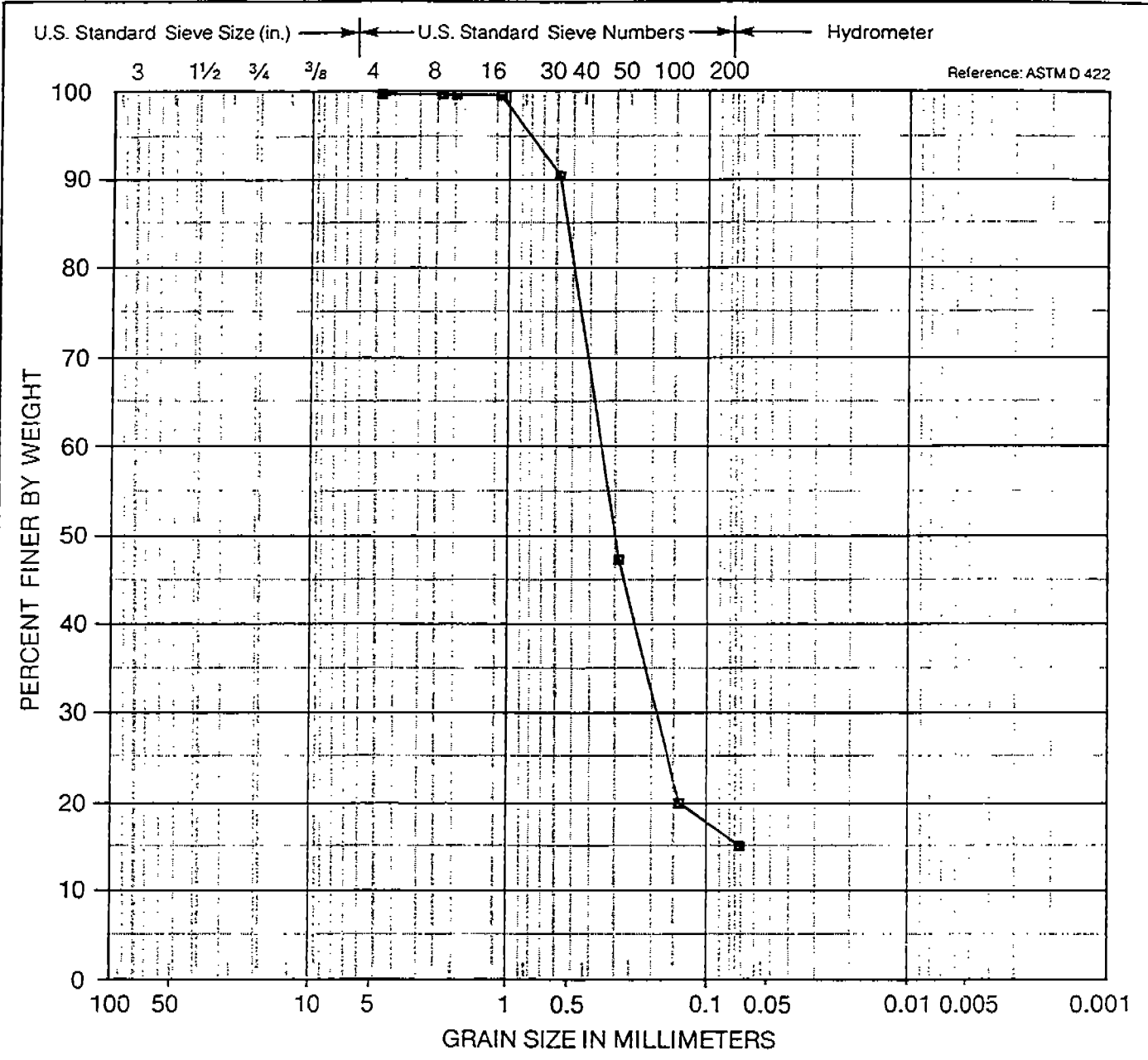

COBBLES	COARSE	FINE	COARSE	MEDIUM	FINE	SILT OR CLAY
	GRAVEL		SAND			

Symbol	Sample Source	Classification
■	SB16-16 @ 4.0 FT	BROWN SILTY SAND (SM)



Particle Size Analysis

PLATE

Particle Size Analysis
Sieve Method
HLA Laboratory Analysis Routines Ver 3.0

Project Name: HLA-FORT ORD
Project Number: HLA.2-4376

Test Date: 11-16-1993
Location: SB-16-18 @ 5.0

Total Sample Weight (g): 731.3
Percent Passing No. 10 Sieve : 0.0
Representative Sample Weight (g): ----

PI Results (used in determining fines classification)

Liquid Limit: --- Plasticity Index: ---

Soil Composition (%)	Particle Diameter (mm):
Gravel : 0.0	@ 60% Passing : 0.3787
Sand : 90.6	@ 30% Passing : 0.2135
Fines : 9.4	@ 10% Passing : 0.0809

Coefficient of Uniformity: 4.68E 0

Coefficient of Curvature: 1.49E 0

Soil Classification: YELLOW-BROWN SAND W/SILT (SP-SM*)

Frost Classification: --

Data Entry By: CLM

File #: 614

Particle Size Analysis
Sieve Method
HLA Laboratory Analysis Routines Ver 3.0

Project : HLA-FORT ORD ID : HLA.2-4376 Test Date : 11-16-1993

Data Entry By : CLM Location : SB-16-18 @ 5.0 Data File : TEST0614

Sieve Name	Sieve Size (mm)	Cum. Weight Retained (g)	Percent of Total Weight Passing
5.000 in	125.000	0.0	100.0
3.000 in	75.000	0.0	100.0
1.500 in	37.500	0.0	100.0
3/4 in	19.000	0.0	100.0
3/8 in	9.500	0.0	100.0
No. 4	4.750	0.0	100.0
No. 8	2.360	0.4	99.9
No. 10	2.000	0.9	99.9
No. 16	1.180	2.8	99.6
No. 30	0.600	71.5	90.2
No. 50	0.300	404.4	44.7
No. 100	0.150	623.6	14.7
No. 200	0.075	662.4	9.4

U.S. Standard Sieve Size (in.) U.S. Standard Sieve Numbers Hydrometer

3 1½ ¾ ⅜ 4 8 16 30 40 50 100 200

Reference: ASTM D 422

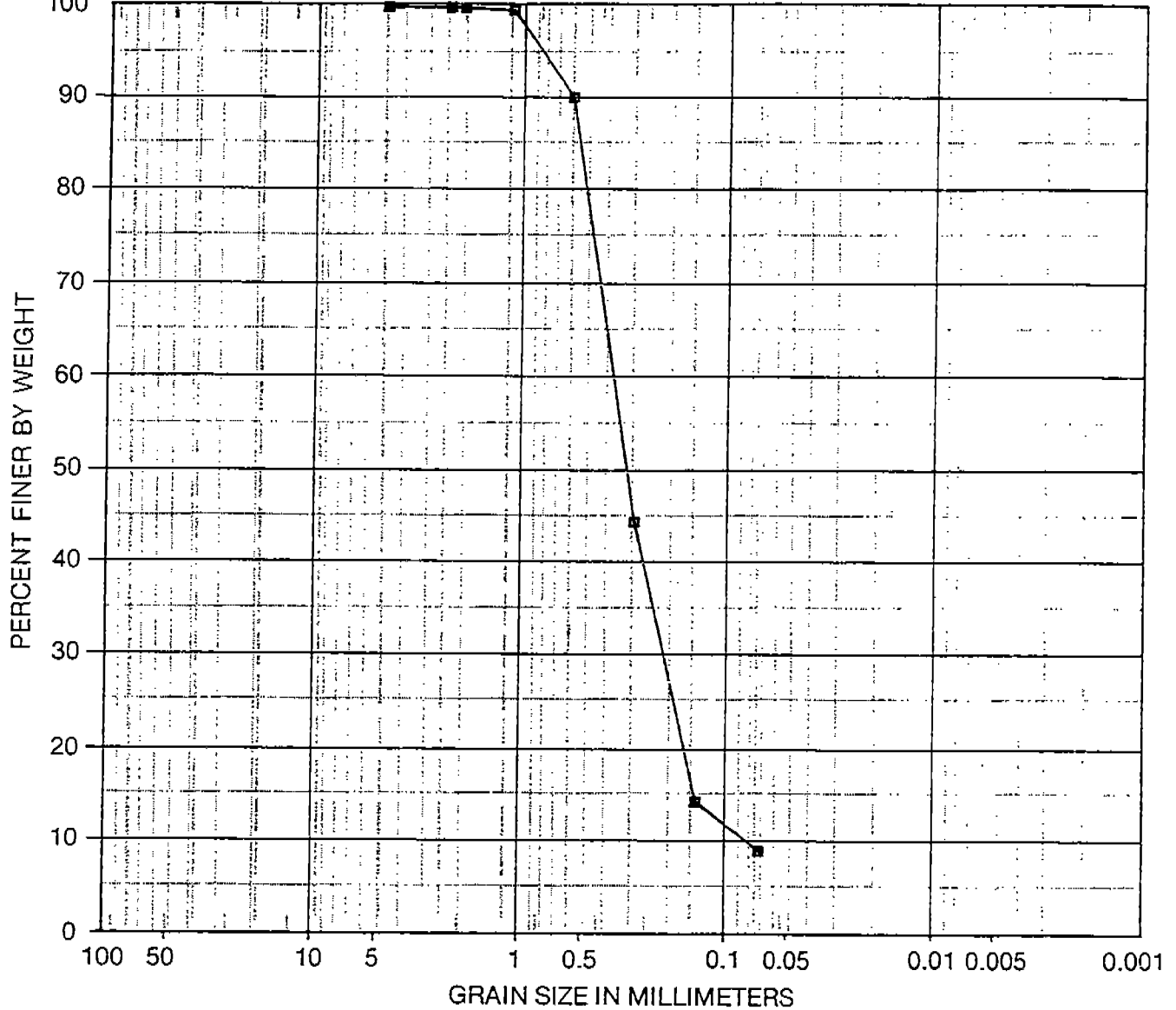

COBBLES	COARSE	FINE	COARSE	MEDIUM	FINE	SILT OR CLAY
	GRAVEL		SAND			

Symbol	Sample Source	Classification
■	SB-16-18 @ 5.0 FT	YELLOW-BROWN SAND W/SILT (SP-SM)



Particle Size Analysis

PLATE

Particle Size Analysis
Sieve Method
HLA Laboratory Analysis Routines Ver 3.0

Project Name: HLA-FORT ORD 16/17
Project Number: 23366-4469

Test Date: 03-29-1994
Location: SB-16-24 @ 3.0

Total Sample Weight (g): 410.3
Percent Passing No. 10 Sieve : 0.0
Representative Sample Weight (g): ----

PI Results (used in determining fines classification)

Liquid Limit: 0 Plasticity Index: 0

Soil Composition (%): Particle Diameter (mm):
Gravel : 10.6 @ 60% Passing : 0.4275
Sand : 80.7 @ 30% Passing : 0.2164
Fines : 8.7 @ 10% Passing : 0.0900

Coefficient of Uniformity: 4.75E 0

Coefficient of Curvature: 1.22E 0

Soil Classification: DARK BROWN SAND W/SILT (SP-SM*)

Frost Classification: --

Data Entry By: FF

File #: 404

Particle Size Analysis
Sieve Method
HLA Laboratory Analysis Routines Ver 3.0

Project : HLA-FORT ORD 16/17 ID : 23366-4469 Test Date : 03-29-1994
Data Entry By : FF Location : SB-16-24 @ 3.0 Data File : TEST0404

Sieve Name	Sieve Size (mm)	Cum. Weight Retained (g)	Percent of Total Weight Passing
5.000 in	125.000	0.0	100.0
3.000 in	75.000	0.0	100.0
1.500 in	37.500	0.0	100.0
3/4 in	19.000	0.0	100.0
3/8 in	9.500	29.7	92.8
No. 4	4.750	43.4	89.4
No. 8	2.360	58.1	85.8
No. 10	2.000	60.7	85.2
No. 16	1.180	69.1	83.2
No. 30	0.600	104.0	74.7
No. 50	0.300	226.9	44.7
No. 100	0.150	354.9	13.5
No. 200	0.075	374.4	8.7

U.S. Standard Sieve Size (in.) U.S. Standard Sieve Numbers Hydrometer

3 1½ ¾ ⅜ 4 8 16 30 40 50 100 200

Reference: ASTM D 422

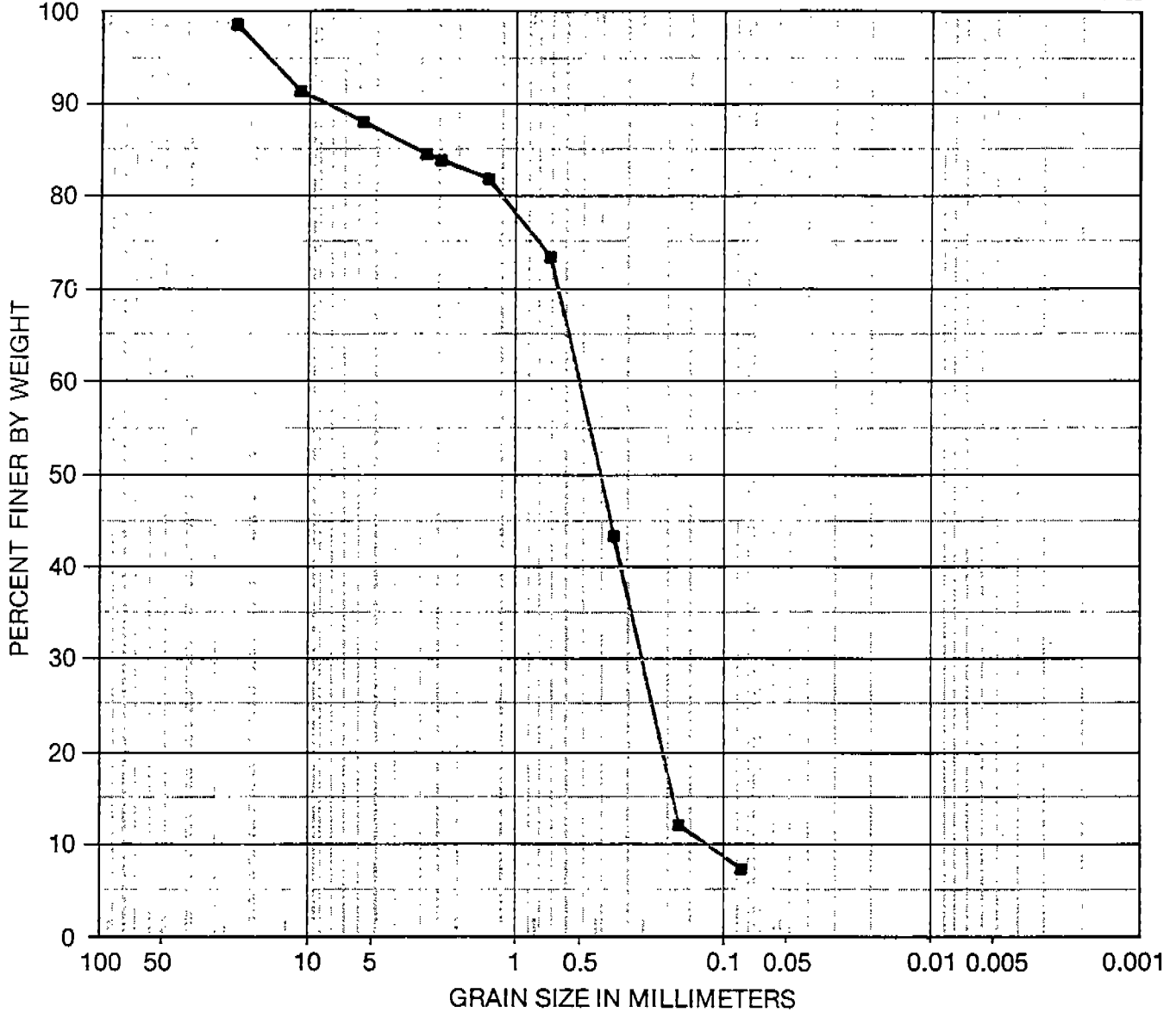

COBBLES	COARSE	FINE	COARSE	MEDIUM	FINE	SILT OR CLAY
	GRAVEL			SAND		

Symbol	Sample Source	Classification
■	SB-16-24 @ 3.0 FT	DARK BROWN SAND W/SILT (SP-SM)



Particle Size Analysis

PLATE

Particle Size Analysis
Sieve Method
HLA Laboratory Analysis Routines Ver 3.0

Project Name: HLA-FORT ORD 16/17
Project Number: 23366-4469

Test Date: 03-29-1994
Location: SB-16-24 @ 17.5

Total Sample Weight (g): 428.2
Percent Passing No. 10 Sieve : 0.0
Representative Sample Weight (g): ----

PI Results (used in determining fines classification)

Liquid Limit: 0 Plasticity Index: 0

Soil Composition (%)	Particle Diameter (mm):
Gravel : 0.0	@ 60% Passing : 0.3290
Sand : 98.3	@ 30% Passing : 0.2108
Fines : 1.7	@ 10% Passing : 0.1594

Coefficient of Uniformity: 2.06E 0

Coefficient of Curvature: 8.47E-1

Soil Classification: BROWN SAND (SP)

Frost Classification: --

Data Entry By: FF

File #: 405

Particle Size Analysis
Sieve Method
HLA Laboratory Analysis Routines Ver 3.0

Project : HLA-FORT ORD 16/17 ID : 23366-4469 Test Date : 03-29-1994

Data Entry By : FF Location : SB-16-24 @ 17.5 Data File : TEST0405

Sieve Name	Sieve Size (mm)	Cum. Weight Retained (g)	Percent of Total Weight Passing
5.000 in	125.000	0.0	100.0
3.000 in	75.000	0.0	100.0
1.500 in	37.500	0.0	100.0
3/4 in	19.000	0.0	100.0
3/8 in	9.500	0.0	100.0
No. 4	4.750	0.0	100.0
No. 8	2.360	0.0	100.0
No. 10	2.000	0.0	100.0
No. 16	1.180	1.0	99.8
No. 30	0.600	39.0	90.9
No. 50	0.300	191.6	55.3
No. 100	0.150	404.1	5.6
No. 200	0.075	421.1	1.7

U.S. Standard Sieve Size (in.) U.S. Standard Sieve Numbers Hydrometer

3 1½ ¾ ⅜ 4 8 16 30 40 50 100 200

Reference: ASTM D 422

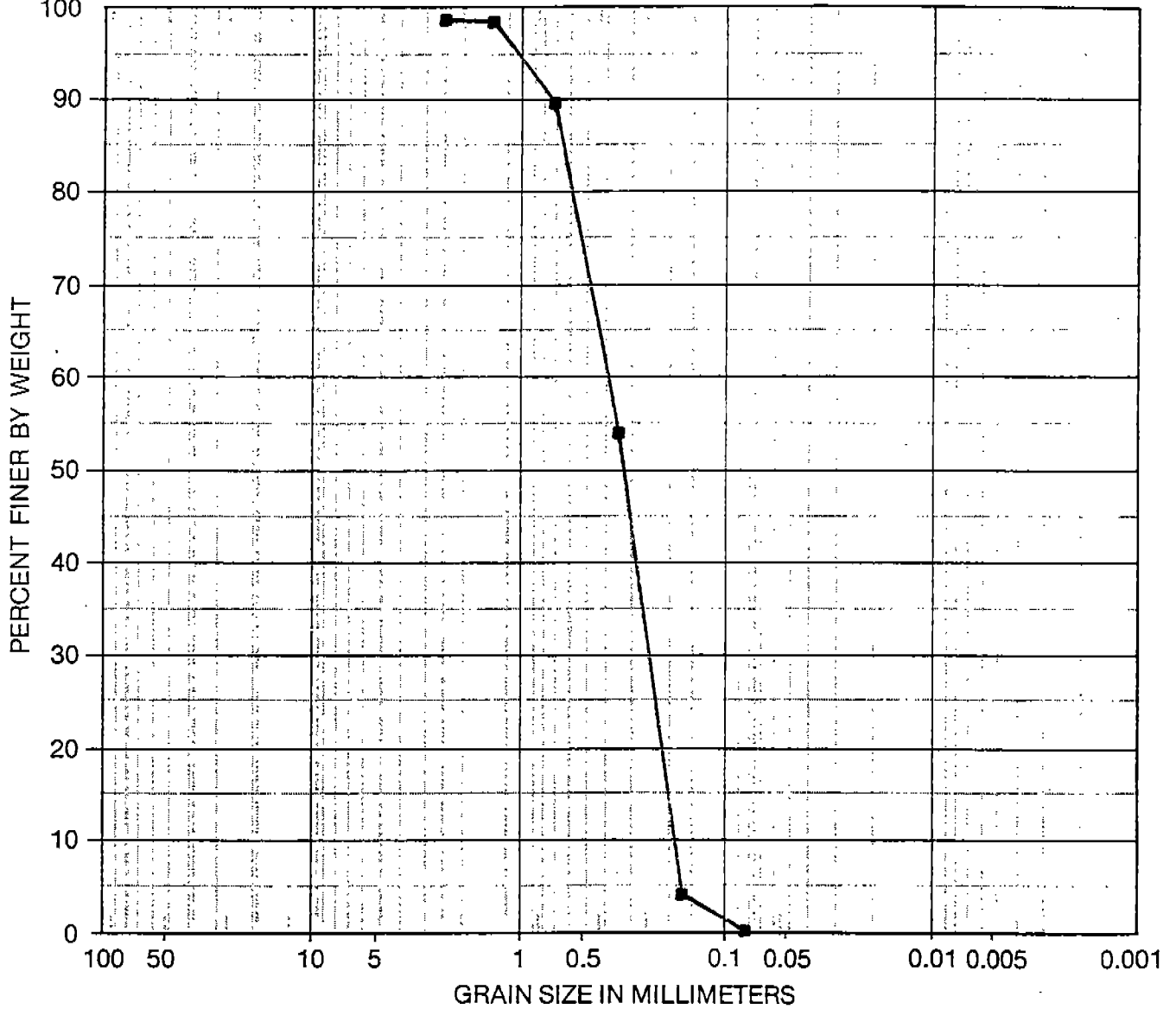

COBBLES	COARSE	FINE	COARSE	MEDIUM	FINE	SILT OR CLAY
	GRAVEL		SAND			

Symbol	Sample Source	Classification
■	SB-16-24 @ 17.5 FT	BROWN SAND (SP)



SOLEA TESTING GROUP

Particle Size Analysis

PLATE

Particle Size Analysis
Sieve Method
HLA Laboratory Analysis Routines Ver 3.0

Project Name: HLA-FORT ORD 16/17
Project Number: 23366-4469

Test Date: 03-29-1994
Location: SB-16-26 @ 2.5

Total Sample Weight (g): 382.3
Percent Passing No. 10 Sieve : 0.0
Representative Sample Weight (g): ----

PI Results (used in determining fines classification)

Liquid Limit: 0 Plasticity Index: 0

Soil Composition (%) :	Particle Diameter (mm) :
Gravel : 0.6	@ 60% Passing : 0.3317
Sand : 82.3	@ 30% Passing : 0.1735
Fines : 17.1	@ 10% Passing : 0.0333

Coefficient of Uniformity: 9.97E 0

Coefficient of Curvature: 2.73E 0

Soil Classification: MED. BROWN SILTY SAND (SM*)

Frost Classification: --

Data Entry By: FF

File #: 400

Particle Size Analysis
Sieve Method
HLA Laboratory Analysis Routines Ver 3.0

Project : HLA-FORT ORD 16/17 ID : 23366-4469 Test Date : 03-29-1994
Data Entry By : FF Location : SB-16-26 @ 2.5 Data File : TEST0400

Sieve Name	Sieve Size (mm)	Cum. Weight Retained (g)	Percent of Total Weight Passing
5.000 in	125.000	0.0	100.0
3.000 in	75.000	0.0	100.0
1.500 in	37.500	0.0	100.0
3/4 in	19.000	0.0	100.0
3/8 in	9.500	1.2	99.7
No. 4	4.750	2.3	99.4
No. 8	2.360	8.4	97.8
No. 10	2.000	10.1	97.4
No. 16	1.180	19.0	95.0
No. 30	0.600	59.3	84.5
No. 50	0.300	168.8	55.8
No. 100	0.150	293.9	23.1
No. 200	0.075	317.0	17.1

U.S. Standard Sieve Size (in.) U.S. Standard Sieve Numbers Hydrometer

Reference: ASTM D 422

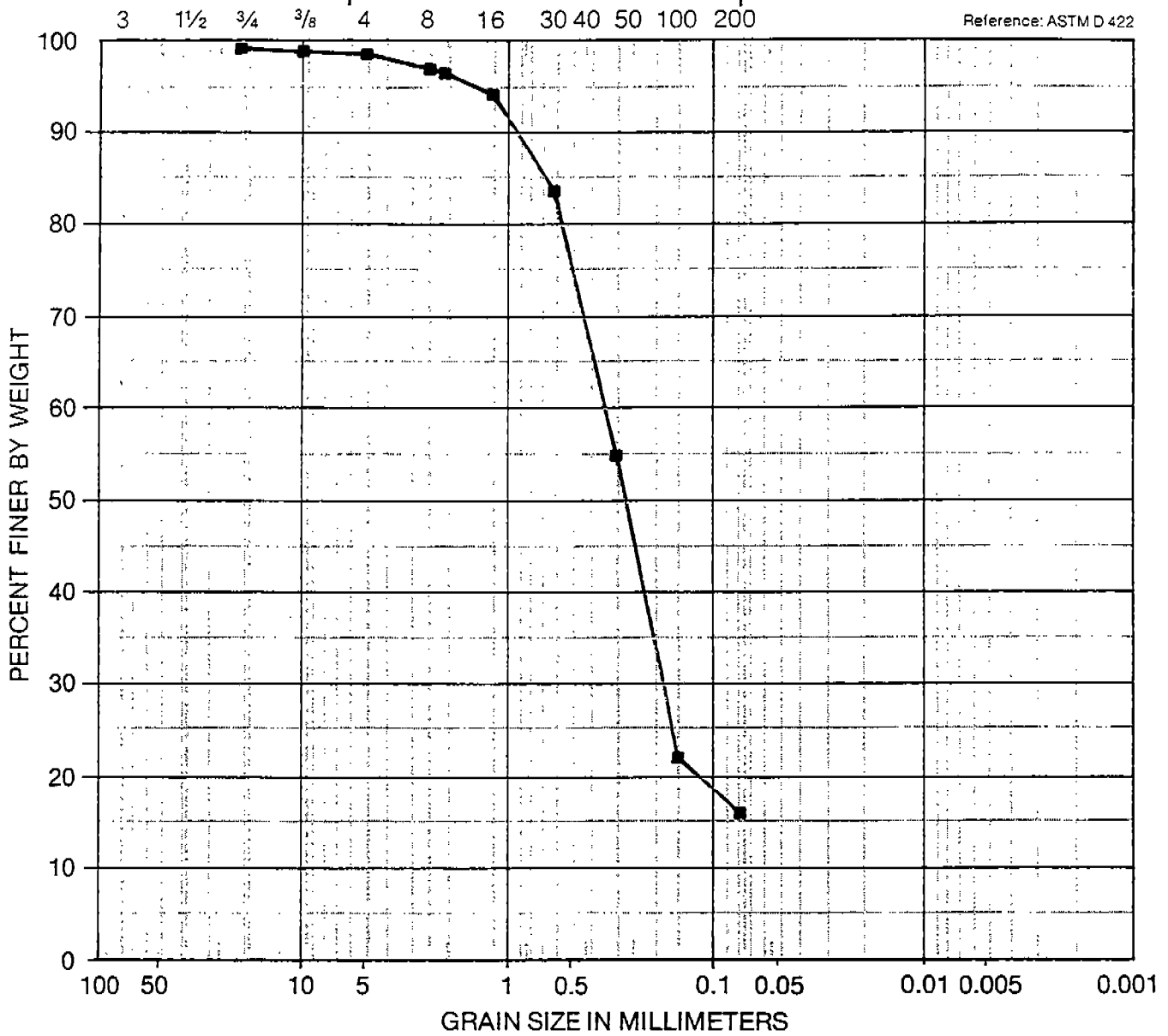

COBBLES	COARSE	FINE	COARSE	MEDIUM	FINE	SILT OR CLAY
	GRAVEL		SAND			

Symbol	Sample Source	Classification
■	SB-16-26 @ 2.5 FT	MED. BROWN SILTY SAND (SM)



Particle Size Analysis

PLATE

Particle Size Analysis
Sieve Method
HLA Laboratory Analysis Routines Ver 3.0

Project Name: HLA-FORT ORD 16/17
Project Number: 23366-4469

Test Date: 03-29-1994
Location: SB-16-26 @ 16.5

Total Sample Weight (g): 415.0
Percent Passing No. 10 Sieve : 0.0
Representative Sample Weight (g): ----

PI Results (used in determining fines classification)

Liquid Limit: 0 Plasticity Index: 0

Soil Composition (%) :	Particle Diameter (mm) :
Gravel : 0.0	@ 60% Passing : 0.3782
Sand : 97.0	@ 30% Passing : 0.2463
Fines : 3.0	@ 10% Passing : 0.1667

Coefficient of Uniformity: 2.27E 0

Coefficient of Curvature: 9.63E-1

Soil Classification: LIGHT BROWN SAND (SP*)

Frost Classification: --

Data Entry By: FF

File #: 399

Particle Size Analysis
Sieve Method
HLA Laboratory Analysis Routines Ver 3.0

Project : HLA-FORT ORD 16/17 ID : 23366-4469 Test Date : 03-29-1994

Data Entry By : FF Location : SB-16-26 @ 16.5 Data File : TEST0399

<u>Sieve Name</u>	<u>Sieve Size (mm)</u>	<u>Cum. Weight Retained (g)</u>	<u>Percent of Total Weight Passing</u>
5.000 in	125.000	0.0	100.0
3.000 in	75.000	0.0	100.0
1.500 in	37.500	0.0	100.0
3/4 in	19.000	0.0	100.0
3/8 in	9.500	0.0	100.0
No. 4	4.750	0.0	100.0
No. 8	2.360	0.0	100.0
No. 10	2.000	0.0	100.0
No. 16	1.180	0.0	100.0
No. 30	0.600	1.3	99.7
No. 50	0.300	248.6	40.1
No. 100	0.150	395.9	4.6
No. 200	0.075	402.6	3.0

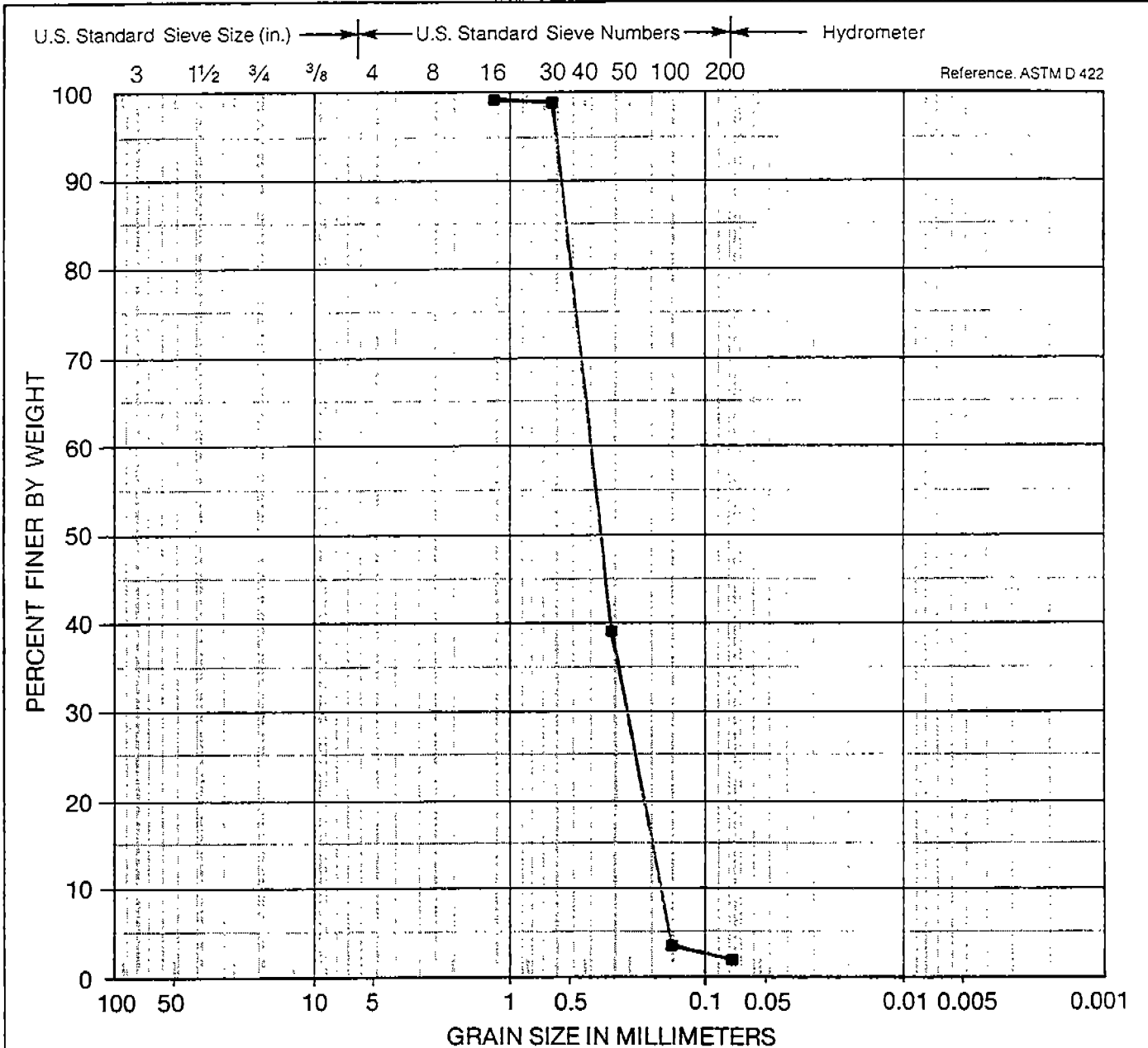

Reference: ASTM D 422

COBBLES	COARSE	FINE	COARSE	MEDIUM	FINE	SILT OR CLAY
	GRAVEL		SAND			

Symbol	Sample Source	Classification
■	SB-16-26 @ 16.5 FT	LIGHT BROWN SAND (SP)



SOLEA TESTING GROUP

Particle Size Analysis

PLATE

Particle Size Analysis
Sieve Method
HLA Laboratory Analysis Routines Ver 3.0

Project Name: HLA-FORT ORD 16/17
Project Number: 23366-4469

Test Date: 03-29-1994
Location: SB-17-07 @ 4.5

Total Sample Weight (g): 437.0
Percent Passing No. 10 Sieve : 0.0
Representative Sample Weight (g): ----

PI Results (used in determining fines classification)

Liquid Limit: 0 Plasticity Index: 0

Soil Composition (%)	Particle Diameter (mm)
Gravel : 0.0	@ 60% Passing : 0.3860
Sand : 98.4	@ 30% Passing : 0.2355
Fines : 1.6	@ 10% Passing : 0.1640

Coefficient of Uniformity: 2.35E 0

Coefficient of Curvature: 8.76E-1

Soil Classification: LIGHT BROWN SAND (SP*)

Frost Classification: --

Data Entry By: FF

File #: 398

Particle Size Analysis
Sieve Method
HLA Laboratory Analysis Routines Ver 3.0

Project : HLA-FORT ORD 16/17 ID : 23366-4469 Test Date : 03-29-1994
Data Entry By : FF Location : SB-17-07 @ 4.5 Data File : TEST0398

Sieve Name	Sieve Size (mm)	Cum. Weight Retained (g)	Percent of Total Weight Passing
5.000 in	125.000	0.0	100.0
3.000 in	75.000	0.0	100.0
1.500 in	37.500	0.0	100.0
3/4 in	19.000	0.0	100.0
3/8 in	9.500	0.0	100.0
No. 4	4.750	0.0	100.0
No. 8	2.360	0.0	100.0
No. 10	2.000	0.0	100.0
No. 16	1.180	0.4	99.9
No. 30	0.600	47.6	89.1
No. 50	0.300	247.5	43.4
No. 100	0.150	414.8	5.1
No. 200	0.075	430.0	1.6

U.S. Standard Sieve Size (in.) U.S. Standard Sieve Numbers Hydrometer

3 1½ ¾ ⅜ 4 8 16 30 40 50 100 200

Reference: ASTM D 422

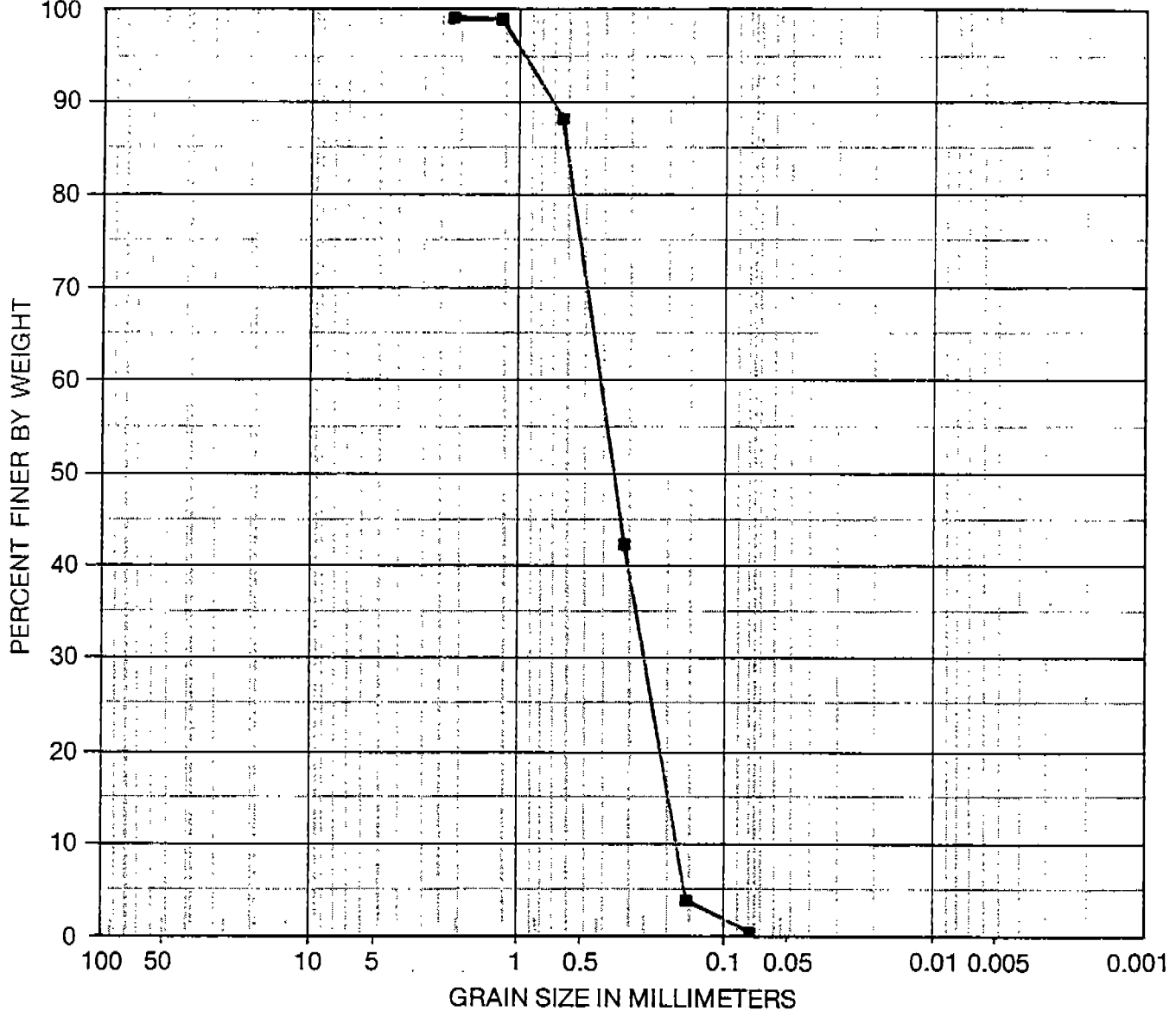

COBBLES	COARSE	FINE	COARSE	MEDIUM	FINE	SILT OR CLAY
	GRAVEL		SAND			

Symbol	Sample Source	Classification
■	SB-17-07 @ 4.5 FT	LIGHT BROWN SAND (SP)



SOLEA TESTING GROUP

Particle Size Analysis

PLATE

Particle Size Analysis
Sieve Method
HLA Laboratory Analysis Routines Ver 3.0

Project Name: HLA-FORT ORD 16/17
Project Number: 23366-4469

Test Date: 03-29-1994
Location: SB-17-07 @ 20.0

Total Sample Weight (g): 419.9
Percent Passing No. 10 Sieve : 0.0
Representative Sample Weight (g): ----

PI Results (used in determining fines classification)

Liquid Limit: 0 Plasticity Index: 0

Soil Composition (%):

Particle Diameter (mm):

Gravel :	0.0	@ 60% Passing :	0.5537
Sand :	98.3	@ 30% Passing :	0.3282
Fines :	1.7	@ 10% Passing :	0.1776

Coefficient of Uniformity: 3.12E 0

Coefficient of Curvature: 1.10E 0

Soil Classification: LIGHT BROWN SAND (SP*)

Frost Classification: --

Data Entry By: FF

File #: 397

Particle Size Analysis
Sieve Method
HLA Laboratory Analysis Routines Ver 3.0

Project : HLA-FORT ORD 16/17 ID : 23366-4469 Test Date : 03-29-1994

Data Entry By : FF Location : SB-17-07 @ 20.0 Data File : TEST0397

<u>Sieve Name</u>	<u>Sieve Size (mm)</u>	<u>Cum. Weight Retained (g)</u>	<u>Percent of Total Weight Passing</u>
5.000 in	125.000	0.0	100.0
3.000 in	75.000	0.0	100.0
1.500 in	37.500	0.0	100.0
3/4 in	19.000	0.0	100.0
3/8 in	9.500	0.0	100.0
No. 4	4.750	0.0	100.0
No. 8	2.360	0.0	100.0
No. 10	2.000	0.0	100.0
No. 16	1.180	2.8	99.3
No. 30	0.600	148.6	64.6
No. 50	0.300	315.6	24.8
No. 100	0.150	398.0	5.2
No. 200	0.075	412.9	1.7

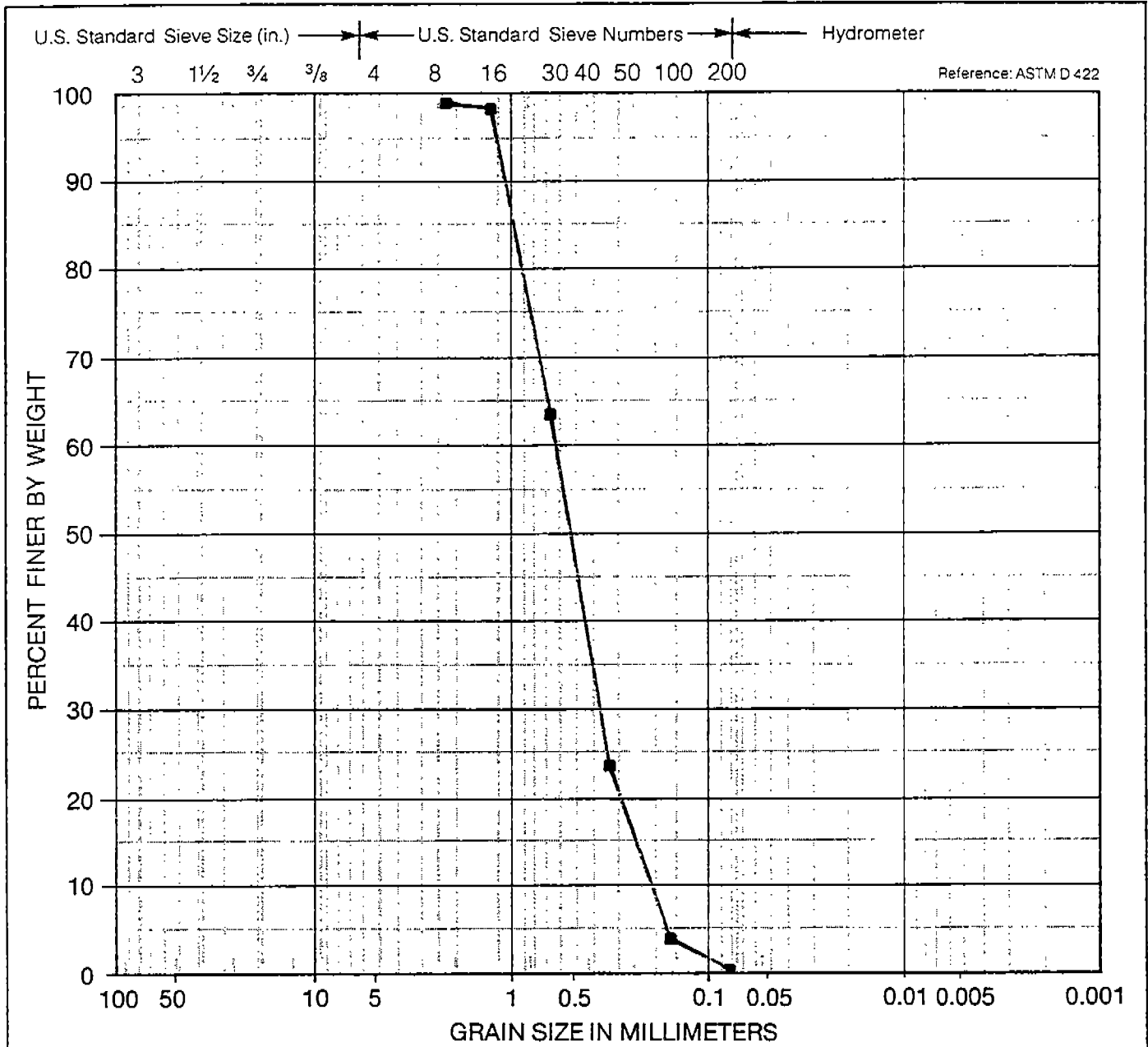

COBBLES	COARSE	FINE	COARSE	MEDIUM	FINE	SILT OR CLAY
	GRAVEL		SAND			

Symbol	Sample Source	Classification
■	SB-17-07 @ 20.0 FT	LIGHT BROWN SAND (SP)



Particle Size Analysis

PLATE

Particle Size Analysis
Sieve Method
HLA Laboratory Analysis Routines Ver 3.0

Project Name: HLA-FORT ORD 16/17
Project Number: 23366-4469

Test Date: 03-29-1994
Location: SB-17-08 @ 15.5

Total Sample Weight (g): 456.8
Percent Passing No. 10 Sieve : 0.0
Representative Sample Weight (g): ----

PI Results (used in determining fines classification)

Liquid Limit: 0 Plasticity Index: 0

Soil Composition (%): Particle Diameter (mm):
Gravel : 0.0 @ 60% Passing : 0.3750
Sand : 95.4 @ 30% Passing : 0.2218
Fines : 4.6 @ 10% Passing : 0.1499

Coefficient of Uniformity: 2.50E 0

Coefficient of Curvature: 8.75E-1

Soil Classification: BROWN SAND (SP)

Frost Classification: --

Data Entry By: FF

File #: 401

Particle Size Analysis
Sieve Method
HLA Laboratory Analysis Routines Ver 3.0

Project : HLA-FORT ORD 16/17 ID : 23366-4469 Test Date : 03-29-1994
Data Entry By : FF Location : SB-17-08 @ 15.5 Data File : TEST0401

Sieve Name	Sieve Size (mm)	Cum. Weight Retained (g)	Percent of Total Weight Passing
5.000 in	125.000	0.0	100.0
3.000 in	75.000	0.0	100.0
1.500 in	37.500	0.0	100.0
3/4 in	19.000	0.0	100.0
3/8 in	9.500	0.0	100.0
No. 4	4.750	0.0	100.0
No. 8	2.360	0.6	99.9
No. 10	2.000	0.7	99.8
No. 16	1.180	1.3	99.7
No. 30	0.600	42.5	90.7
No. 50	0.300	249.3	45.4
No. 100	0.150	411.1	10.0
No. 200	0.075	435.9	4.6

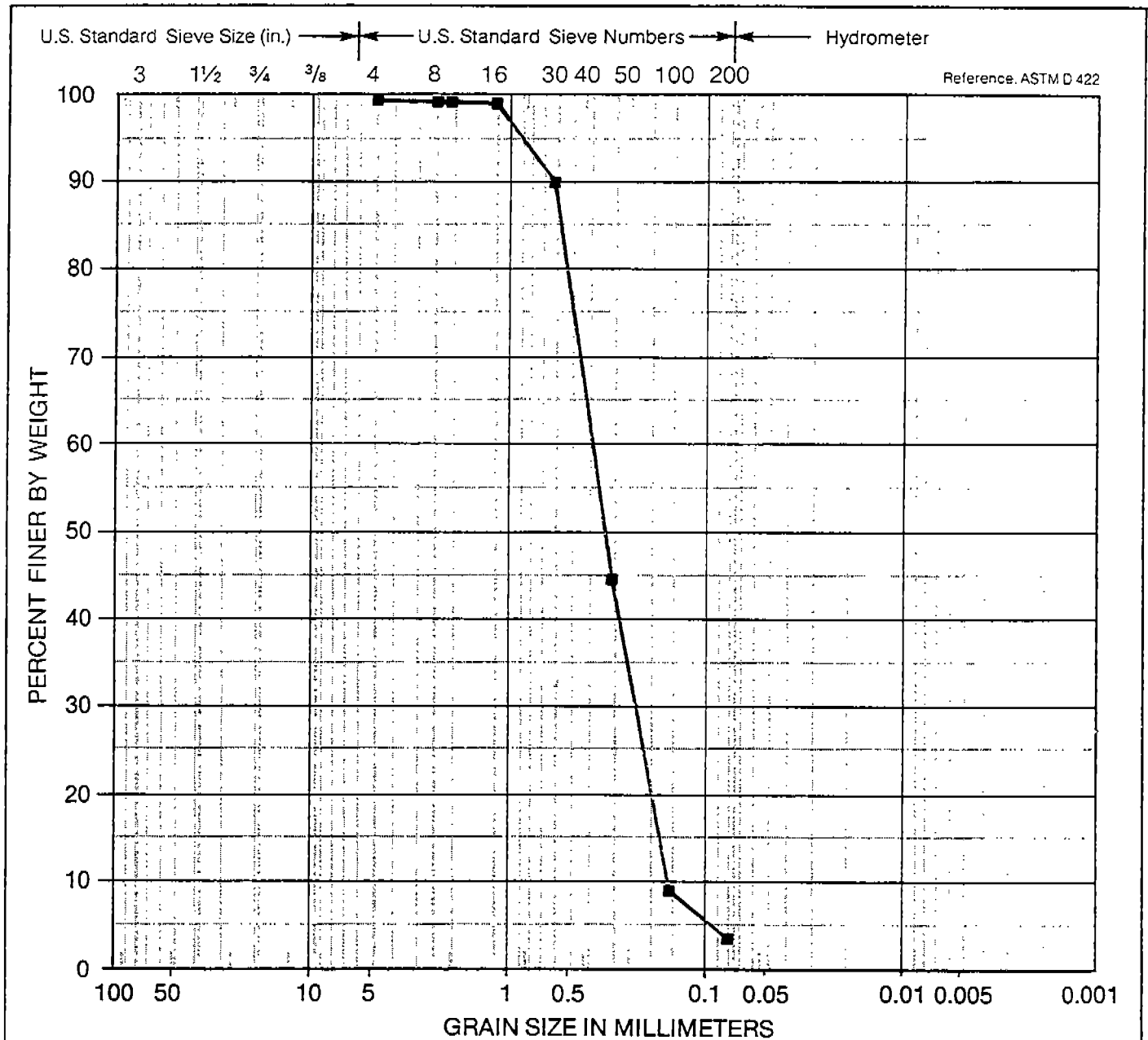

COBBLES	COARSE	FINE	COARSE	MEDIUM	FINE	SILT OR CLAY
	GRAVEL		SAND			

Symbol	Sample Source	Classification
■	SB-17-08 @ 15.5 FT	BROWN SAND (SP)



Particle Size Analysis

PLATE

Particle Size Analysis
Sieve Method
HLA Laboratory Analysis Routines Ver 3.0

Project Name: HLA-FORT ORD 16/17
Project Number: 23366-4469

Test Date: 03-29-1994
Location: SB-17-08 @ 35.5

Total Sample Weight (g): 449.2
Percent Passing No. 10 Sieve : 0.0
Representative Sample Weight (g): ----

PI Results (used in determining fines classification)

Liquid Limit: 0 Plasticity Index: 0

Soil Composition (%): Particle Diameter (mm):
Gravel : 0.0 @ 60% Passing : 0.4706
Sand : 99.4 @ 30% Passing : 0.3163
Fines : 0.6 @ 10% Passing : 0.1888

Coefficient of Uniformity: 2.49E 0
Coefficient of Curvature: 1.13E 0

Soil Classification: BROWN SAND (SP)
Frost Classification: --

Data Entry By: FF

File #: 406

Particle Size Analysis
Sieve Method
HLA Laboratory Analysis Routines Ver 3.0

Project : HLA-FORT ORD 16/17 ID : 23366-4469 Test Date : 03-29-1994

Data Entry By : FF Location : SB-17-08 @ 35.5 Data File : TEST0406

Sieve Name	Sieve Size (mm)	Cum. Weight Retained (g)	Percent of Total Weight Passing
5.000 in	125.000	0.0	100.0
3.000 in	75.000	0.0	100.0
1.500 in	37.500	0.0	100.0
3/4 in	19.000	0.0	100.0
3/8 in	9.500	0.0	100.0
No. 4	4.750	0.0	100.0
No. 8	2.360	0.0	100.0
No. 10	2.000	0.0	100.0
No. 16	1.180	0.3	99.9
No. 30	0.600	97.3	78.3
No. 50	0.300	332.4	26.0
No. 100	0.150	440.0	2.0
No. 200	0.075	446.3	0.6

U.S. Standard Sieve Size (in.) U.S. Standard Sieve Numbers Hydrometer

3 1½ ¾ ⅜ 4 8 16 30 40 50 100 200

Reference: ASTM D 422

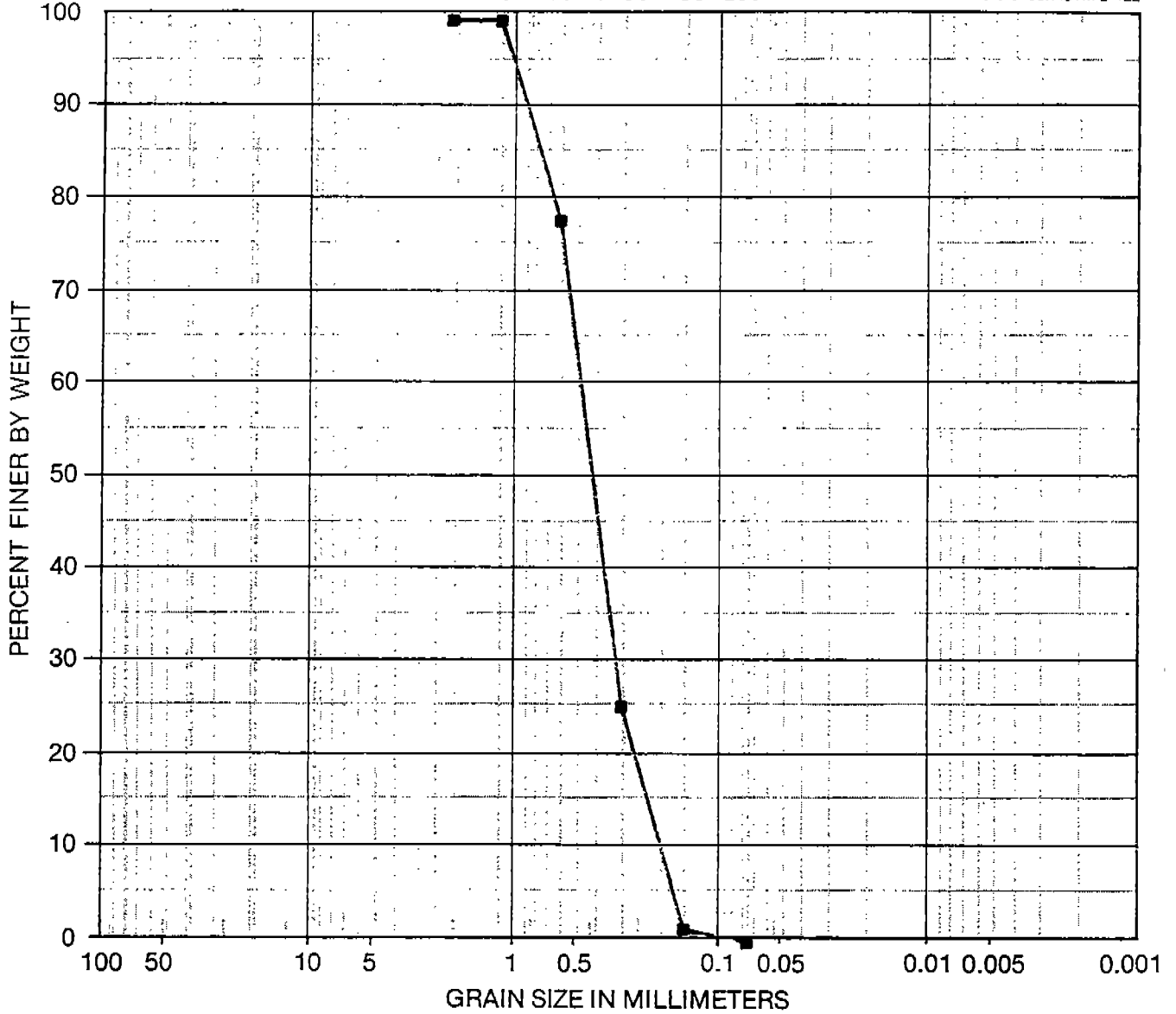

COBBLES	COARSE	FINE	COARSE	MEDIUM	FINE	SILT OR CLAY
	GRAVEL		SAND			

Symbol	Sample Source	Classification
■	SB-17-08 @ 35.5 FT	BROWN SAND (SP)

Particle Size Analysis

PLATE



Particle Size Analysis
Sieve Method
HLA Laboratory Analysis Routines Ver 3.0

Project Name: HLA-FORT ORD 16/17
Project Number: 23366-4469

Test Date: 03-29-1994
Location: SB-17-11 @ 1.5

Total Sample Weight (g): 438.7
Percent Passing No. 10 Sieve : 0.0
Representative Sample Weight (g): ----

PI Results (used in determining fines classification)

Liquid Limit: 0 Plasticity Index: 0

Soil Composition (%): Particle Diameter (mm):
Gravel : 1.1 @ 60% Passing : 0.4102
Sand : 87.5 @ 30% Passing : 0.2147
Fines : 11.4 @ 10% Passing : 0.0601

Coefficient of Uniformity: 6.82E 0

Coefficient of Curvature: 1.87E 0

Soil Classification: YELLOW BROWN SAND W/SILT (SW-SM*)

Frost Classification: --

Data Entry By: FF

File #: 395

Particle Size Analysis
Sieve Method
HLA Laboratory Analysis Routines Ver 3.0

Project : HLA-FORT ORD 16/17 ID : 23366-4469 Test Date : 03-29-1994
Data Entry By : FF Location : SB-17-11 @ 1.5 Data File : TEST0395

Sieve Name	Sieve Size (mm)	Cum. Weight Retained (g)	Percent of Total Weight Passing
5.000 in	125.000	0.0	100.0
3.000 in	75.000	0.0	100.0
1.500 in	37.500	0.0	100.0
3/4 in	19.000	0.0	100.0
3/8 in	9.500	5.0	98.9
No. 4	4.750	5.0	98.9
No. 8	2.360	5.8	98.7
No. 10	2.000	6.0	98.6
No. 16	1.180	7.5	98.3
No. 30	0.600	86.3	80.3
No. 50	0.300	248.8	43.3
No. 100	0.150	369.5	15.8
No. 200	0.075	388.7	11.4

U.S. Standard Sieve Size (in.) U.S. Standard Sieve Numbers Hydrometer

Reference: ASTM D 422

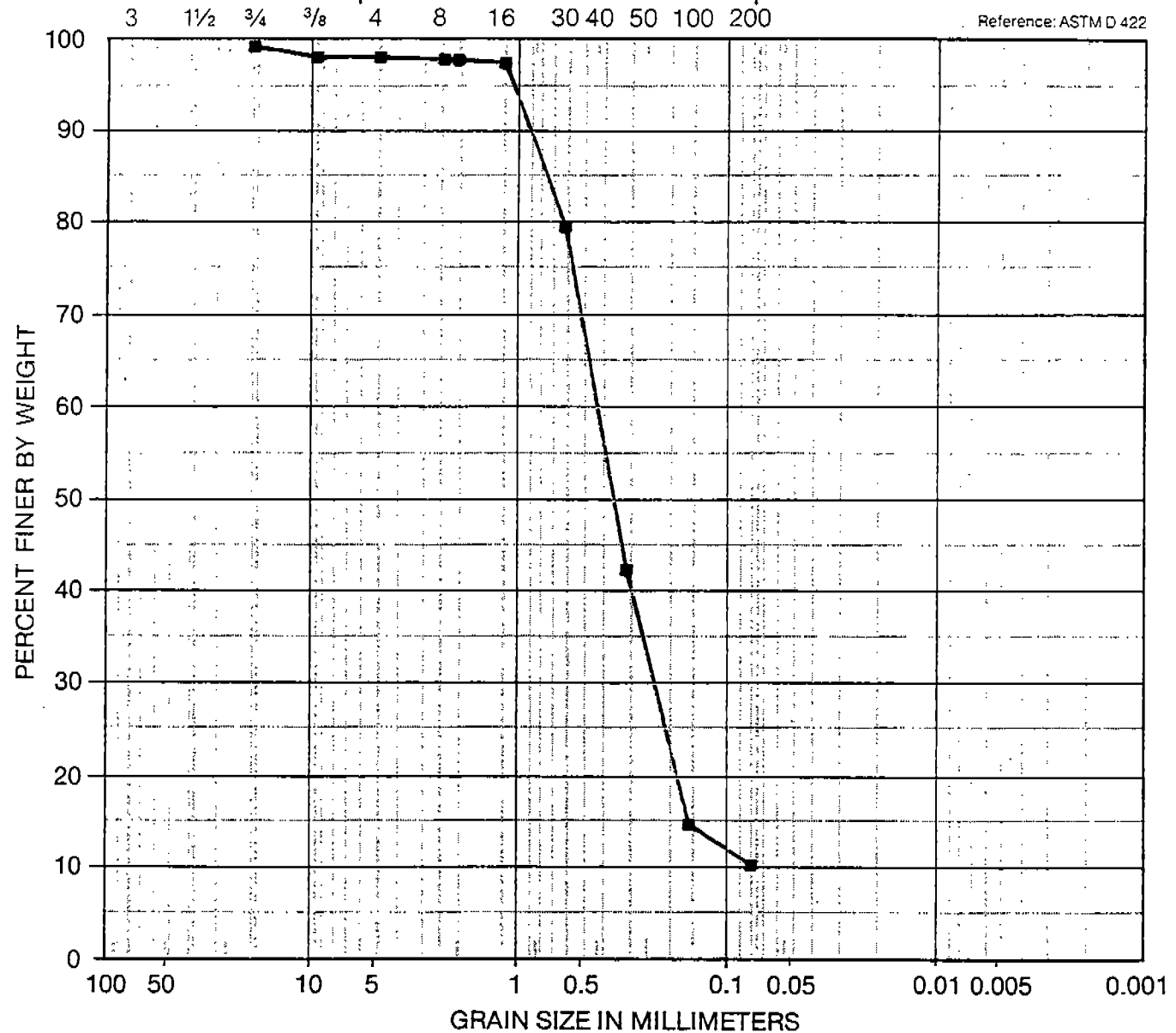

COBBLES	COARSE	FINE	COARSE	MEDIUM	FINE	SILT OR CLAY
	GRAVEL		SAND			

Symbol	Sample Source	Classification
■	SB-17-11 @ 1.5 FT	YELLOW BROWN SAND W/SILT (SW-SM)

Particle Size Analysis

PLATE



SOLEA TESTING GROUP

Particle Size Analysis
Sieve Method
HLA Laboratory Analysis Routines Ver 3.0

Project Name: HLA-FORT ORD 16/17
Project Number: 23366-4469

Test Date: 03-29-1994
Location: SB-17-11 @ 11.5

Total Sample Weight (g): 369.4
Percent Passing No. 10 Sieve : 0.0
Representative Sample Weight (g): ----

PI Results (used in determining fines classification)

Liquid Limit: 0 Plasticity Index: 0

Soil Composition (%) : Particle Diameter (mm) :
Gravel : 0.5 @ 60% Passing : 0.3591
Sand : 89.9 @ 30% Passing : 0.2031
Fines : 9.6 @ 10% Passing : 0.0802

Coefficient of Uniformity: 4.48E 0

Coefficient of Curvature: 1.43E 0

Soil Classification: BROWN SAND W/SILT (SP-SM)

Frost Classification: F2**

Data Entry By: FF

File #: 394

Particle Size Analysis
Sieve Method
HLA Laboratory Analysis Routines Ver 3.0

Project : HLA-FORT ORD 16/17 ID : 23366-4469 Test Date : 03-29-1994

Data Entry By : FF Location : SB-17-11 @ 11.5 Data File : TEST0394

Sieve Name	Sieve Size (mm)	Cum. Weight Retained (g)	Percent of Total Weight Passing
5.000 in	125.000	0.0	100.0
3.000 in	75.000	0.0	100.0
1.500 in	37.500	0.0	100.0
3/4 in	19.000	0.0	100.0
3/8 in	9.500	0.0	100.0
No. 4	4.750	1.8	99.5
No. 8	2.360	5.1	98.6
No. 10	2.000	5.9	98.4
No. 16	1.180	9.0	97.6
No. 30	0.600	50.0	86.5
No. 50	0.300	182.0	50.7
No. 100	0.150	318.0	13.9
No. 200	0.075	334.0	9.6

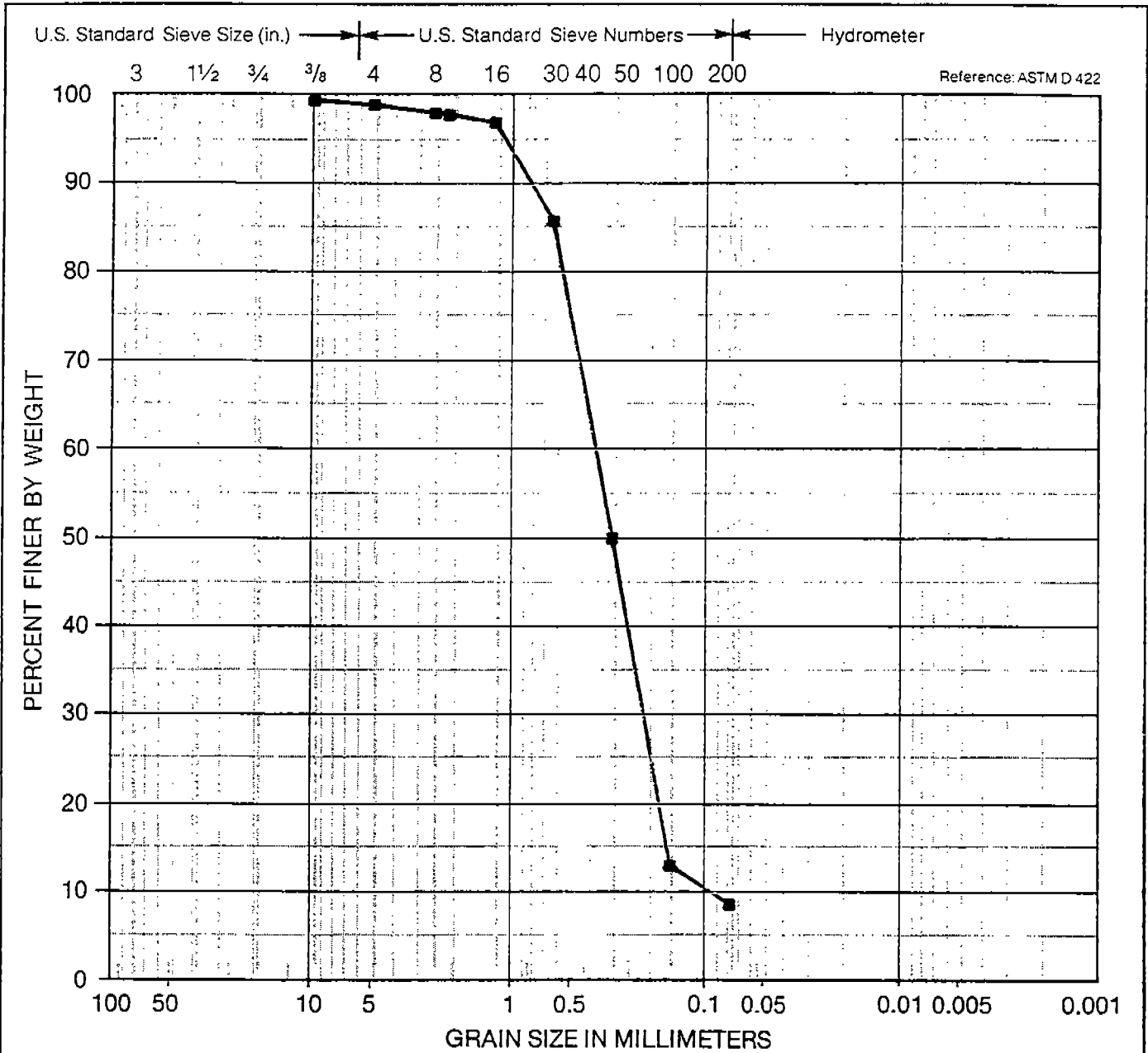

COBBLES	COARSE	FINE	COARSE	MEDIUM	FINE	SILT OR CLAY
	GRAVEL		SAND			
Symbol	Sample Source				Classification	
■	SB-17-11 @ 11.5 FT				BROWN SAND W/SILT (SP-SM)	



Particle Size Analysis

PLATE

Particle Size Analysis
Sieve Method
HLA Laboratory Analysis Routines Ver 3.0

Project Name: HLA-FORT ORD 16/17
Project Number: 23366-4469

Test Date: 03-29-1994
Location: SB-17-11 @ 22.5

Total Sample Weight (g): 396.3
Percent Passing No. 10 Sieve : 0.0
Representative Sample Weight (g): ----

PI Results (used in determining fines classification)

Liquid Limit: 0 Plasticity Index: 0

Soil Composition (%): Particle Diameter (mm):
Gravel : 0.0 @ 60% Passing : 0.4013
Sand : 98.7 @ 30% Passing : 0.2465
Fines : 1.3 @ 10% Passing : 0.1684

Coefficient of Uniformity: 2.38E 0

Coefficient of Curvature: 9.00E-1

Soil Classification: LIGHT BROWN SAND (SP*)

Frost Classification: --

Data Entry By: FF

File #: 396

Particle Size Analysis
Sieve Method
HLA Laboratory Analysis Routines Ver 3.0

Project : HLA-FORT ORD 16/17 ID : 23366-4469 Test Date : 03-29-1994
Data Entry By : FF Location : SB-17-11 @ 22.5 Data File : TEST0396

Sieve Name	Sieve Size (mm)	Cum. Weight Retained (g)	Percent of Total Weight Passing
5.000 in	125.000	0.0	100.0
3.000 in	75.000	0.0	100.0
1.500 in	37.500	0.0	100.0
3/4 in	19.000	0.0	100.0
3/8 in	9.500	0.0	100.0
No. 4	4.750	0.0	100.0
No. 8	2.360	0.0	100.0
No. 10	2.000	0.0	100.0
No. 16	1.180	0.8	99.8
No. 30	0.600	50.5	87.3
No. 50	0.300	236.6	40.3
No. 100	0.150	380.7	3.9
No. 200	0.075	391.0	1.3

U.S. Standard Sieve Size (in.) U.S. Standard Sieve Numbers Hydrometer

3 1½ ¾ ⅜ 4 8 16 30 40 50 100 200

Reference: ASTM D 422

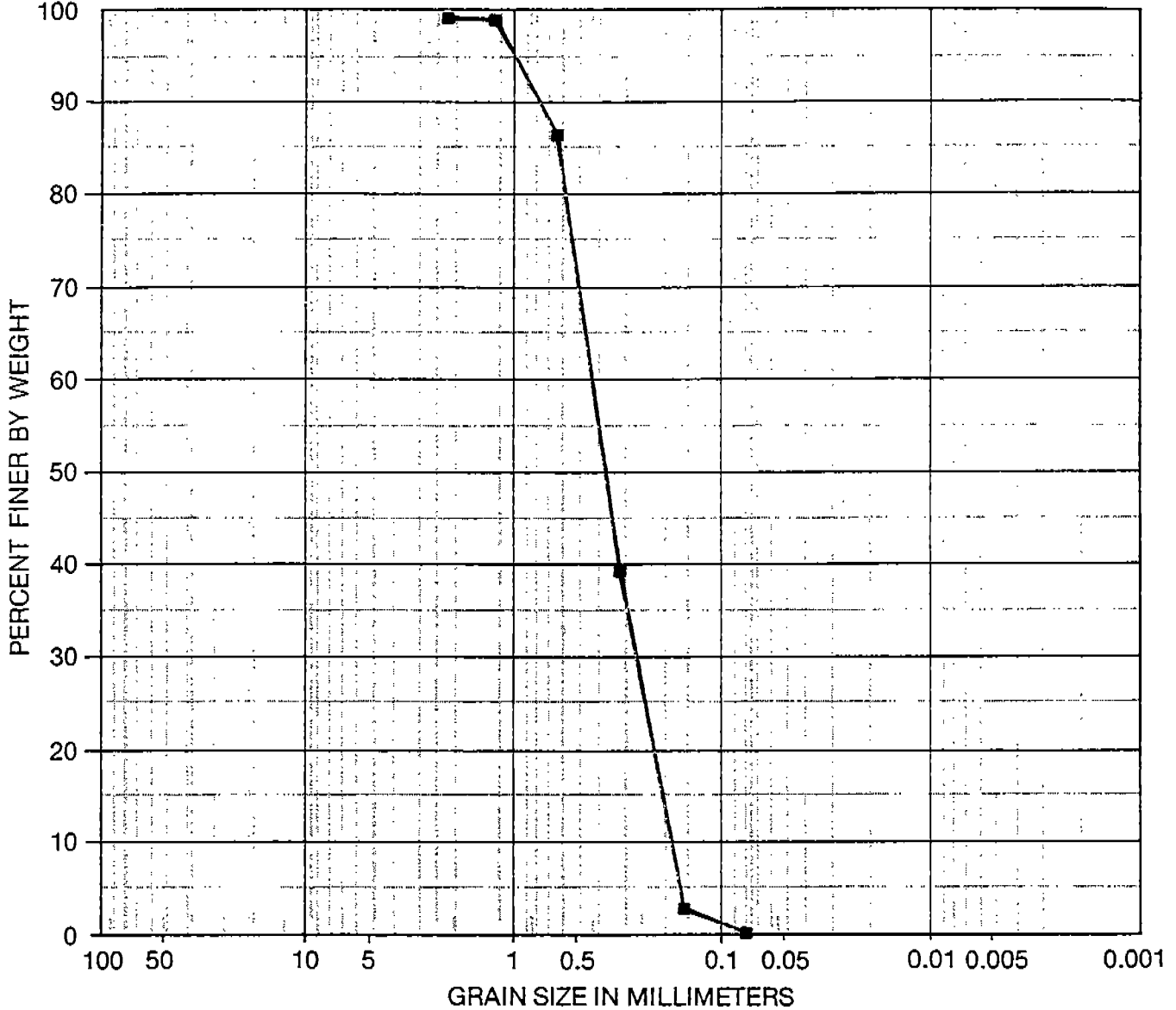

COBBLES	COARSE	FINE	COARSE	MEDIUM	FINE	SILT OR CLAY
	GRAVEL		SAND			

Symbol	Sample Source	Classification
■	SB-17-11 @ 22.5 FT	LIGHT BROWN SAND (SP)



Particle Size Analysis

PLATE

Organic Loss on Ignition Test

Project: HLA Fort Ord Site 16/17 ID: 23366-4469 Test Date: 4/8/94

<u>Boring Desc.</u>	<u>Depth (ft)</u>	<u>Organic Matter (%)</u>
17 - 11	10.5	7.1
17 - 11	5.5	0.6
17 - 11	23.0	2.8
17 - 07	25.0	0.5
17 - 07	10.5	6.2
16 - 26	17.5	0.4
16 - 26	2.5	9.3
17 - 08	15.0	1.6
17 - 08	30.5	0.9
16 - 24	3.5	2.5
16 - 24	18.5	0.5
31 - 23	3.5	2.4
31 - 31	3.5	4.2

LABORATORY COMPACTION TEST

BULK NO.: <u>C-940</u>	LRN: <u>4469</u>	By: <u>FF</u>	Page No. <u>1</u>
JOB NAME: <u>HLA- Fort Ord Site 16/17</u>		JOB NO.: <u>23366-01724</u>	
SAMPLE ID: <u>SB-16-22</u>			
SOIL CLASSIFICATION: <u>Light Brown Sandy Silt (ML)</u>			
NOTES:			
MAXIMUM DRY DENSITY:		<u>125.0 pcf</u>	OPTIMUM MOISTURE CONTENT:
			<u>10.0 %</u>

ASTM: Method: Preparation: Rammer: Other: Non-ASTM: Specific Gravity:	1557-91 A Wet Mechanical	SAMPLE SPLIT	Retained			Sample
			Weight	% Individual	% Cumulative	Weight
		+ 3/4" Sieve				
		+ 3/8" Sieve	0.2	0.4%	0.4%	8.8
		+ #4 Sieve	1.2	2.1%	2.5%	52.6
		- #4 Sieve	55.6	97.5%	100.0%	2438.6
		TOTAL:	57.0	100.0%		2500.0
Classification from Sieve Data:		Sand or finer				

MOISTURE/DENSITY DATA						
	1	2	3	4	5	6
RELATIVE MOISTURE, %	N	3 %	6 %	9 %		
MOLD & WET SOIL, gm.	6130.0	6251.0	6370.0	6317.0		
MOLD, gm.	4295.0	4295.0	4295.0	4295.0		
WET SOIL, gm.	1835.0	1956.0	2075.0	2022.0		
FACTOR 4" / 6" Dia.	.06614 / .0294	.06614 / .0294	.06614 / .0294	.06614 / .0294		
WET DENSITY, pcf	121.4	129.4	137.2	133.7		
PAN NO.	SP-1	SP-7A	SP-7	SP-4		
PAN & WET SOIL, gm.	1427.1	1481.8	1385.1	1467.0		
PAN & DRY SOIL, gm.	1390.2	1412.2	1294.0	1343.3		
MOISTURE LOSS, gm.	36.9	69.6	91.1	123.7		
PAN TARE, gm.	353.9	353.4	354.1	352.0		
DRY SOIL, gm.	1036.3	1058.8	939.9	991.3		
MOISTURE CONTENT, %	3.6	6.6	9.7	12.5		
DRY DENSITY, pcf	117.2	121.4	125.1	118.9		

LF-F100c

CM No: 0178

Checked by: FF

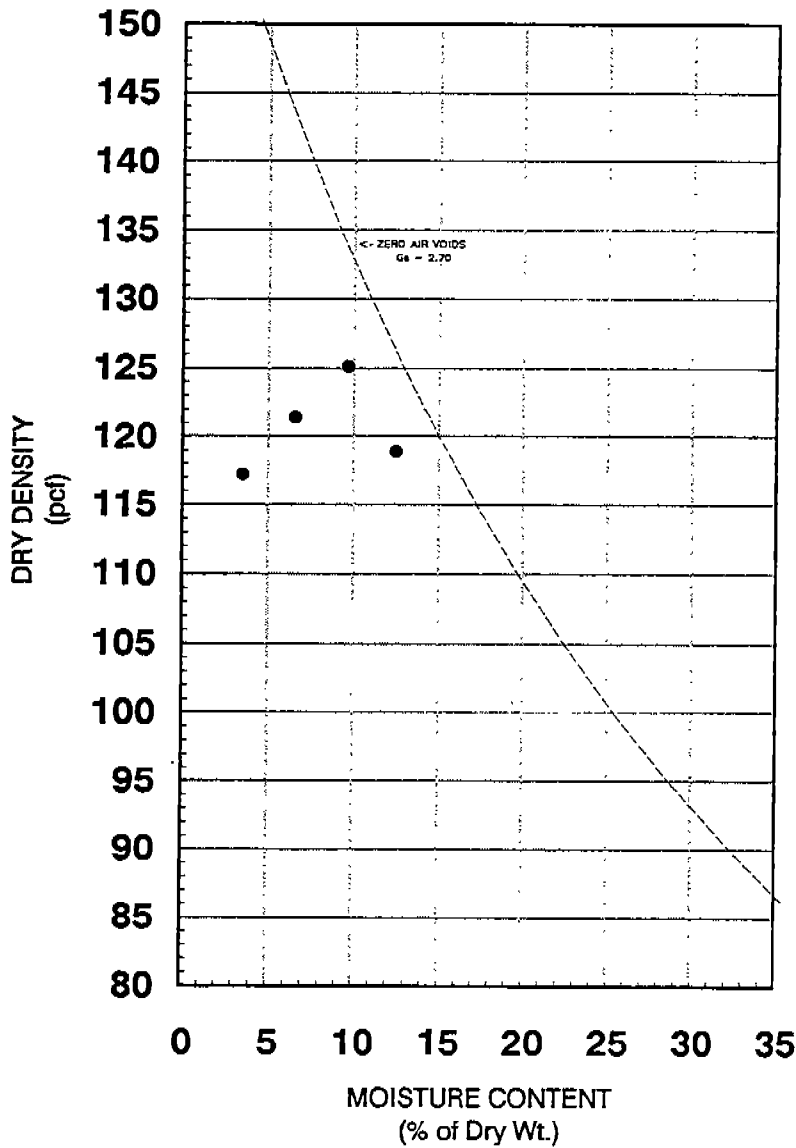

MAXIMUM DRY DENSITY:

125.0 pcf

OPTIMUM MOISTURE CONTENT:

10.0 %

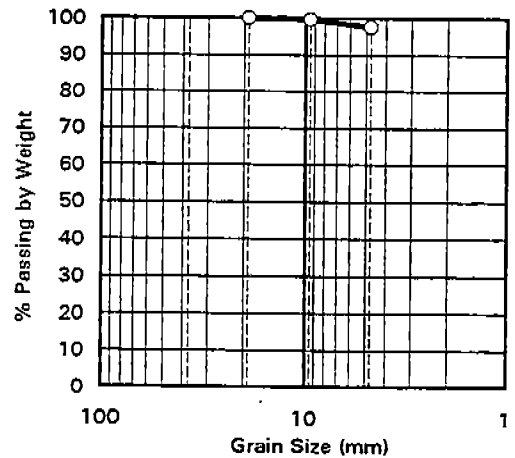

SIEVE DATA

+ 3/4"	+ 19 mm	
+ 3/8"	+ 9.5 mm	0.4 %
+ #4	+ 4.75 mm	2.1 %
- #4	- 4.75 mm	97.5 %

SAMPLE ID:		SB-16-22					
SOIL CLASSIFICATION:		Light Brown Sandy Silt (ML)					
		1	2	3	4	5	6
MOISTURE CONTENT, %		3.6%	6.6%	9.7%	12.5%		
DRY DENSITY, pcf		117.2	121.4	125.1	118.9		
ASTM Method:	Procedure:	Preparation:	Rammer:	Passing 3/4"	Specific Gravity	Other:	
1557-91	A	Wet	Mechanical	100.0%			
NOTES:							

LF-F100r



LABORATORY COMPACTION TEST REPORT

HLA- Fort Ord Site 16/17

LABORATORY COMPACTION TEST

BULK NO.: <u>C-941</u>	LRN: <u>4469</u>	By: <u>FF</u>	Page No. <u>2</u>
JOB NAME: <u>HLA-Fort Ord site 16/17</u>		JOB NO.: <u>23366-01724</u>	
SAMPLE ID: <u>SB-16-24</u>			
SOIL CLASSIFICATION: <u>Dark Brown Sandy Silt (ML)</u>			
NOTES:			

MAXIMUM DRY DENSITY: 116.0 pcf **OPTIMUM MOISTURE CONTENT:** 14.0 %

ASTM:	1557-91	SAMPLE SPLIT	Retained			Sample
			Weight	% Individual	% Cumulative	Weight
Method:	A					
Preparation:	Wet	+ 3/4" Sieve				
Rammer:	Mechanical	+ 3/8" Sieve	1.1	2.5%	2.5%	62.1
Other:		+ #4 Sieve	2.8	6.3%	8.8%	158.0
Non-ASTM:		- #4 Sieve	40.4	91.2%	100.0%	2279.9
Specific Gravity:		TOTAL:	44.3	100.0%		2500.0
Classification from Sieve Data:			Sand or finer			

MOISTURE/DENSITY DATA						
	1	2	3	4	5	6
RELATIVE MOISTURE, %	N	3 %	6 %	9 %		
MOLD & WET SOIL, gm.	6204.0	6263.0	6275.0	6214.0		
MOLD, gm.	4295.0	4295.0	4295.0	4295.0		
WET SOIL, gm.	1909.0	1968.0	1980.0	1919.0		
FACTOR 4" / 6" Dia.	.06614 / .0294	.06614 / .0294	.06614 / .0294	.06614 / .0294		
WET DENSITY, pcf	126.3	130.2	131.0	126.9		
PAN NO.	SP-7	SP-4	SP-5	SP-7A		
PAN & WET SOIL, gm.	1396.0	1559.5	1401.0	1463.4		
PAN & DRY SOIL, gm.	1301.0	1421.0	1254.6	1283.7		
MOISTURE LOSS, gm.	95.0	138.5	146.4	179.7		
PAN TARE, gm.	354.1	352.0	354.4	353.4		
DRY SOIL, gm.	946.9	1069.0	900.2	930.3		
MOISTURE CONTENT, %	10.0	13.0	16.3	19.3		
DRY DENSITY, pcf	114.7	115.2	112.6	106.4		

LF-F100c

CM No: 0177

Checked by: FF

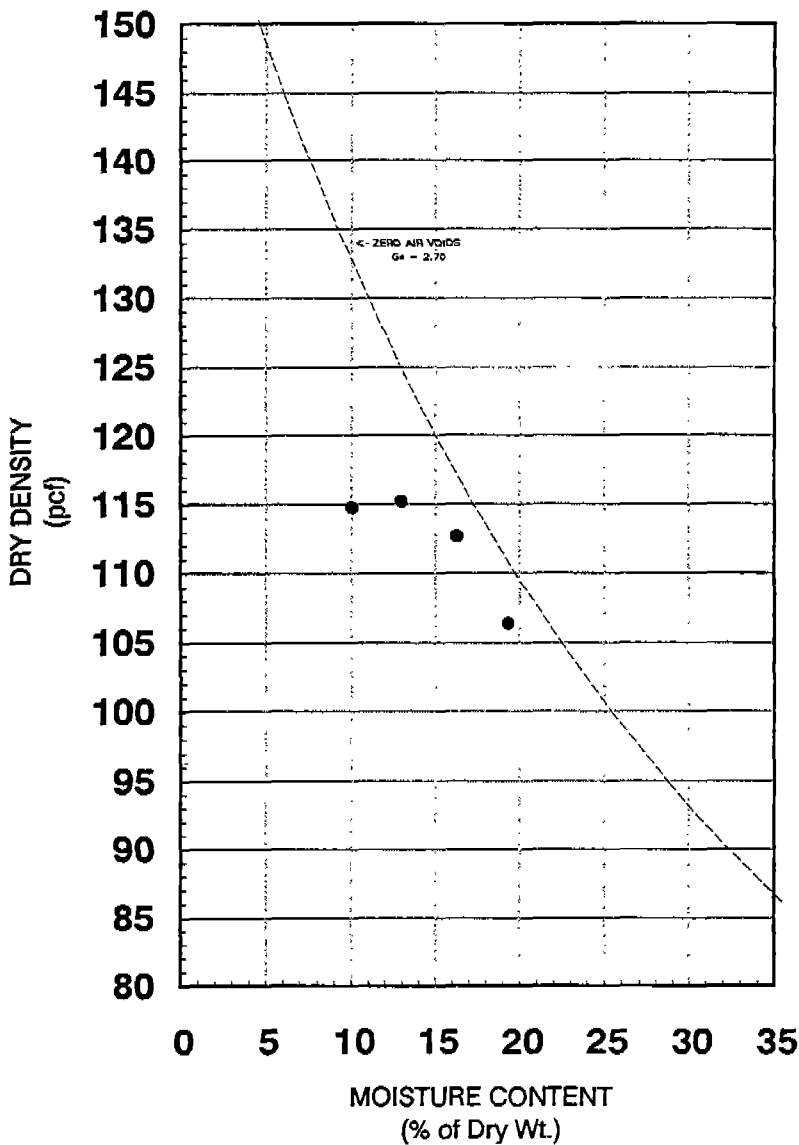

MAXIMUM DRY DENSITY:
116.0 pcf

OPTIMUM MOISTURE CONTENT:
14.0 %

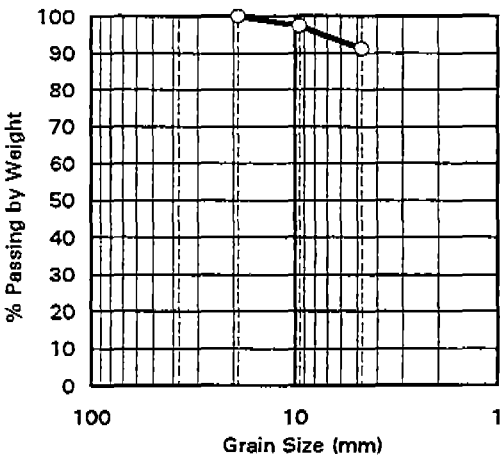

SIEVE DATA		
+ 3/4"	+ 19 mm	
+ 3/8"	+ 9.5 mm	2.5 %
+ #4	+ 4.75 mm	6.3 %
- #4	- 4.75 mm	91.2 %

SAMPLE ID:		SB-16-24					
SOIL CLASSIFICATION:		Dark Brown Sandy Silt (ML)					
		1	2	3	4	5	6
MOISTURE CONTENT, %		10.0%	13.0%	16.3%	19.3%		
DRY DENSITY, pcf		114.7	115.2	112.6	106.4		
ASTM Method:	Procedure:	Preparation:	Rammer:	Passing 3/4"	Specific Gravity	Other:	
1557-91	A	Wet	Mechanical	100.0%			
NOTES:							

LF-F100r



LABORATORY COMPACTION TEST REPORT

HLA-Fort Ord site 16/17

LABORATORY COMPACTION TEST

BULK NO.: <u>C-942</u>	LRN: <u>4469</u>	By: <u>FF</u>	Page No. <u>3</u>
JOB NAME: <u>HLA- Fort Ord</u>		JOB NO.: <u>23366-01724</u>	
SAMPLE ID: <u>SB-16-26</u>			
SOIL CLASSIFICATION: <u>Dark Brown Sandy Silt (ML)</u>			
NOTES:			
MAXIMUM DRY DENSITY: <u>117.0 pcf</u>		OPTIMUM MOISTURE CONTENT: <u>11.0 %</u>	

ASTM: Method: Preparation: Rammer: Other: Non-ASTM: Specific Gravity:	1557-91 A Wet Mechanical	SAMPLE SPLIT	Retained			Sample
			Weight	% Individual	% Cumulative	Weight
		+ 3/4" Sieve				
		+ 3/8" Sieve	0.1	0.2%	0.2%	5.9
		+ #4 Sieve	0.2	0.5%	0.7%	11.8
		- #4 Sieve	42.2	99.3%	100.0%	2482.4
		TOTAL:	42.5	100.0%		2500.0
Classification from Sieve Data:			Sand or finer			

MOISTURE/DENSITY DATA						
	1	2	3	4	5	6
RELATIVE MOISTURE, %	N	3 %	6 %	9 %		
MOLD & WET SOIL, gm.	6160.0	6256.0	6273.0	6181.0		
MOLD, gm.	4295.0	4295.0	4295.0	4295.0		
WET SOIL, gm.	1865.0	1961.0	1978.0	1886.0		
FACTOR 4" / 6" Dia.	.06614 / .0294	.06614 / .0294	.06614 / .0294	.06614 / .0294		
WET DENSITY, pcf	123.4	129.7	130.8	124.7		
PAN NO.	SP-5	SP-4	SP-7	SP-8		
PAN & WET SOIL, gm.	1398.3	1442.3	1390.5	1416.0		
PAN & DRY SOIL, gm.	1321.5	1334.9	1261.6	1260.3		
MOISTURE LOSS, gm.	76.8	107.4	128.9	155.7		
PAN TARE, gm.	354.4	352.0	354.1	355.6		
DRY SOIL, gm.	967.1	982.9	907.5	904.7		
MOISTURE CONTENT, %	7.9	10.9	14.2	17.2		
DRY DENSITY, pcf	114.3	116.9	114.6	106.4		

LF-F100c

CM No: 0178

Checked by: FF

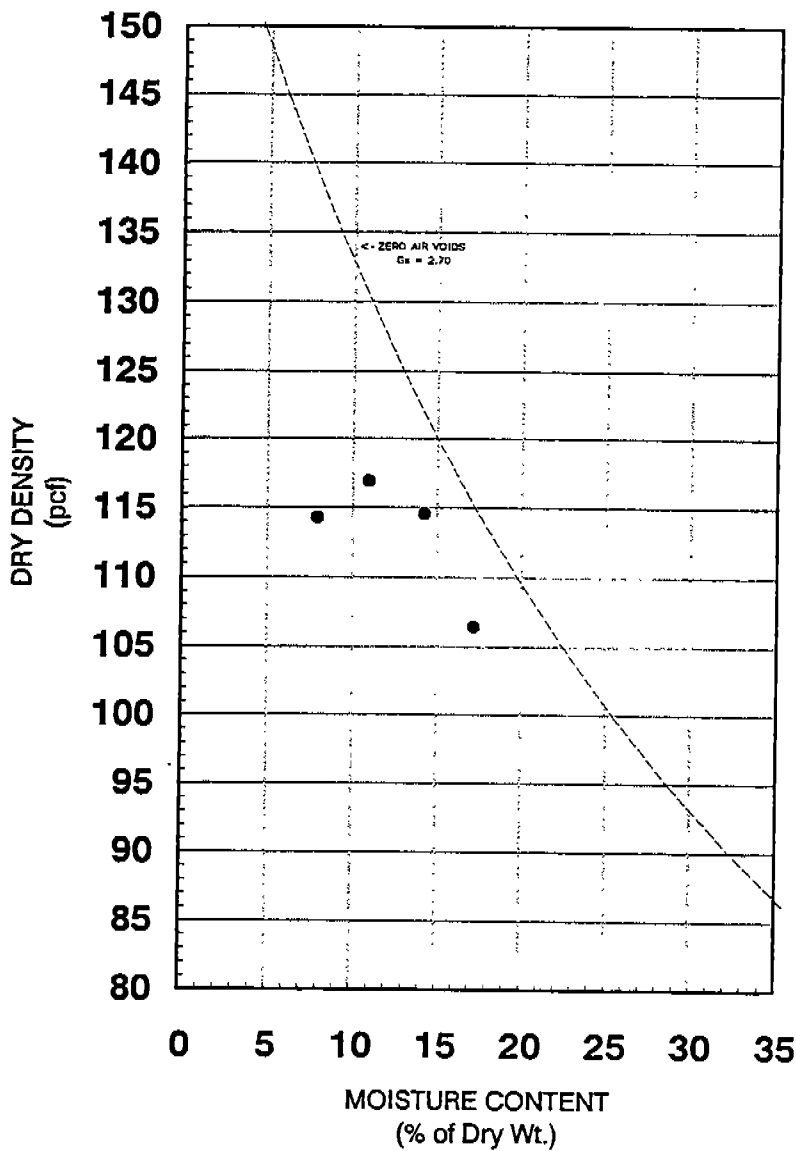

MAXIMUM DRY DENSITY:

117.0 pcf

OPTIMUM MOISTURE CONTENT:

11.0 %

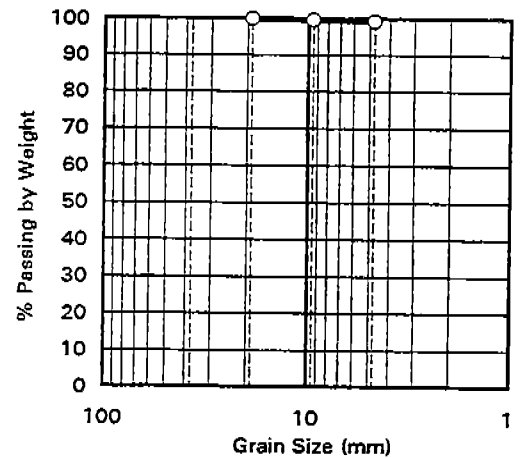

SIEVE DATA

+ 3/4"	+ 19 mm	
+ 3/8"	+ 9.5 mm	0.2 %
+ #4	+ 4.75 mm	0.5 %
- #4	- 4.75 mm	99.3 %

SAMPLE ID:		SB-16-26					
SOIL CLASSIFICATION:		Dark Brown Sandy Silt (ML)					
		1	2	3	4	5	6
MOISTURE CONTENT, %		7.9%	10.9%	14.2%	17.2%		
DRY DENSITY, pcf		114.3	116.9	114.6	106.4		
ASTM Method:	Procedure:	Preparation:	Rammer:	Passing 3/4"	Specific Gravity	Other:	
1557-91	A	Wet	Mechanical	100.0%			
NOTES:							

LF-F100r



LABORATORY COMPACTION TEST REPORT

HLA- Fort Ord

LABORATORY COMPACTION TEST

BULK NO.: <u>C-943</u>	LRN: <u>4469</u>	By: <u>FF</u>	Page No. <u>4</u>
JOB NAME: <u>HLA- Fort Ord Site 16/17</u>		JOB NO.: <u>23366-01724</u>	
SAMPLE ID: <u>SB-17-11</u>			
SOIL CLASSIFICATION: <u>Light Brown Sandy Silt (ML)</u>			
NOTES:			
MAXIMUM DRY DENSITY: <u>122.0 pcf</u>		OPTIMUM MOISTURE CONTENT: <u>9.0 %</u>	

ASTM:	1557-91	SAMPLE SPLIT	Retained			Sample
			Weight	% Individual	% Cumulative	Weight
Method:	A					
Preparation:	Wet	+ 3/4" Sieve	0.2	0.4%	0.4%	9.2
Rammer:	Mechanical	+ 3/8" Sieve	0.4	0.7%	1.1%	18.3
Other:		+ #4 Sieve	0.7	1.3%	2.4%	32.1
Non-ASTM:		- #4 Sieve	53.3	97.6%	100.0%	2440.5
Specific Gravity:		TOTAL:	54.6	100.0%		2500.0
Classification from Sieve Data:			Sand or finer			

MOISTURE/DENSITY DATA						
	1	2	3	4	5	6
RELATIVE MOISTURE, %	N	3 %	6 %	9 %		
MOLD & WET SOIL, gm.	6164.0	6248.0	6296.0	6299.0		
MOLD, gm.	4295.0	4295.0	4295.0	4295.0		
WET SOIL, gm.	1869.0	1953.0	2001.0	2004.0		
FACTOR 4" / 6" Dia.	.06614 / .0294	.06614 / .0294	.06614 / .0294	.06614 / .0294		
WET DENSITY, pcf	123.6	129.2	132.3	132.5		
PAN NO.	R	S	SP-13	SP-3		
PAN & WET SOIL, gm.	1186.7	1254.9	1389.3	1638.5		
PAN & DRY SOIL, gm.	1148.7	1186.1	1294.2	1492.4		
MOISTURE LOSS, gm.	38.0	68.8	95.1	146.1		
PAN TARE, gm.	206	205.5	355.2	359.1		
DRY SOIL, gm.	942.7	980.6	939.0	1133.3		
MOISTURE CONTENT, %	4.0	7.0	10.1	12.9		
DRY DENSITY, pcf	118.8	120.7	120.2	117.4		

LF-F100c

CM No: 0179

Checked by: FF

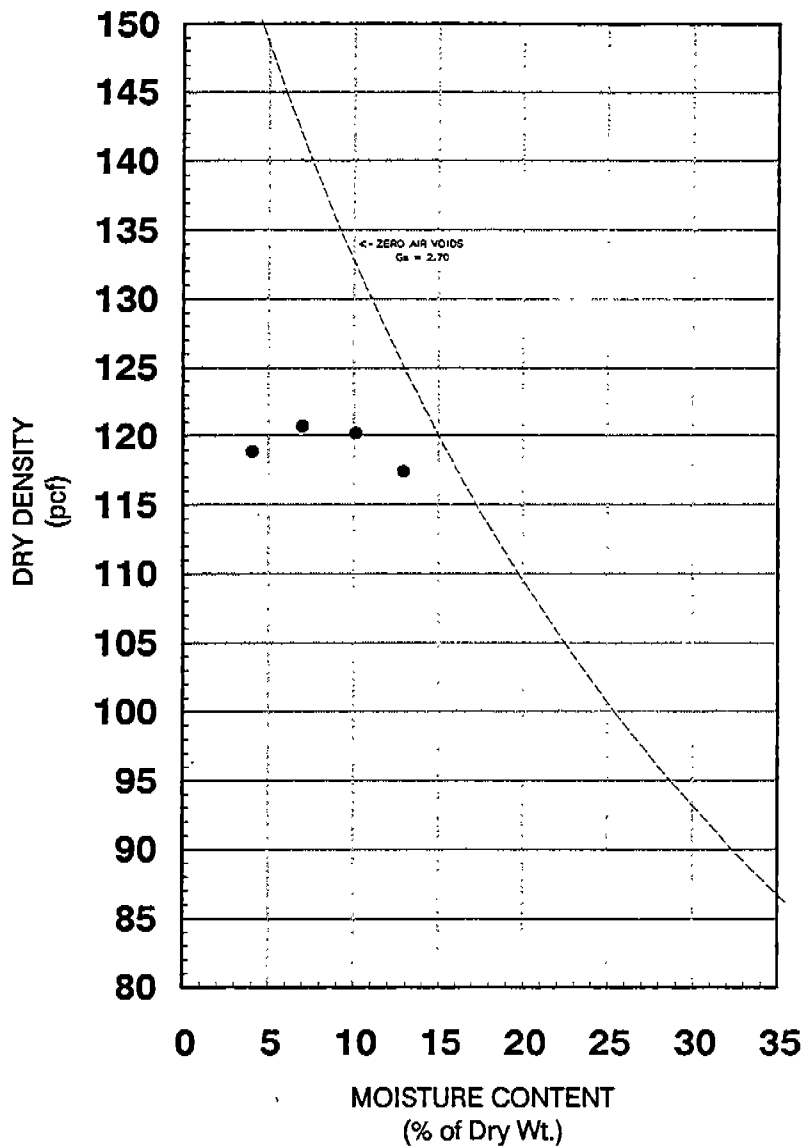

MAXIMUM DRY DENSITY:

122.0 pcf

OPTIMUM MOISTURE CONTENT:

9.0 %

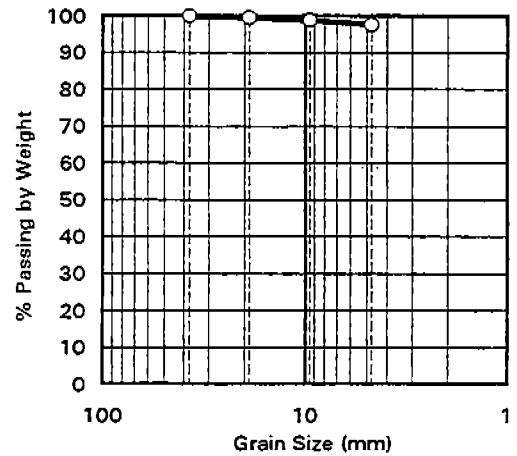

SIEVE DATA

+ 3/4"	+ 19 mm	0.4 %
+ 3/8"	+ 9.5 mm	0.7 %
+ #4	+ 4.75 mm	1.3 %
- #4	- 4.75 mm	97.6 %

SAMPLE ID:		SB-17-11					
SOIL CLASSIFICATION:		Light Brown Sandy Silt (ML)					
		1	2	3	4	5	6
MOISTURE CONTENT, %		4.0%	7.0%	10.1%	12.9%		
DRY DENSITY, pcf		118.8	120.7	120.2	117.4		
ASTM Method:	Procedure:	Preparation:	Rammer:	Passing 3/4"	Specific Gravity	Other:	
1557-91	A	Wet	Mechanical	99.6%			
NOTES:							

LF-F100r



LABORATORY COMPACTION TEST REPORT

HLA- Fort Ord Site 16/17

DRAWN
FF

DATE
4/1/94

PROJECT
23366-01724

LRN
4469

APPROVED
FF

PAGE
4

Consolidation Test Report
HLA Laboratory Analysis Routines Ver 3.0

Project Name: HLA-FORT ORD 16/17
Project Number: 23366-4469

Test Date: 04-05-1994
Location: SB-17-07 @ 4.0

Deformation Dial Constant (in/div): 0.0001

Sample Data:

Diameter (in): 2.43 Initial Height (in): 0.80
Dry Weight (g): 83.4 Specific Gravity (g/cc): 2.70
Overburden (psf): Preconsolidation (psf):
LL: -- PL: -- PI: --
Compression Index:
Specimen Type: UNDISTURBED
Soil Classification: BROWN SAND W/SILT (SP-SM)

Test Results:

	Initial	Final
Moisture Content (%):	4.7	24.8
Void Ratio :	0.97	0.95
Saturation (%) :	13.1	70.2
Dry Density (pcf) :	86	86

Data Entry By: FF

File #: 423

Consolidation Test Report
HLA Laboratory Analysis Routines Ver 3.0

Project : HLA-FORT ORD 16/17 ID : 23366-4469 Test Date : 04-05-1994

Data Entry By : FF Location : SB-17-07 @ 4.0 Data File : TEST0423

Load (psf)	Corrected Deformation (div)	Void Ratio
100	25	0.96
100	-167	1.01
200	-168	1.01
400	-128	1.00
800	-24	0.97
1600	81	0.95
400	96	0.94
100	59	0.95

PRESSURE (ksf)

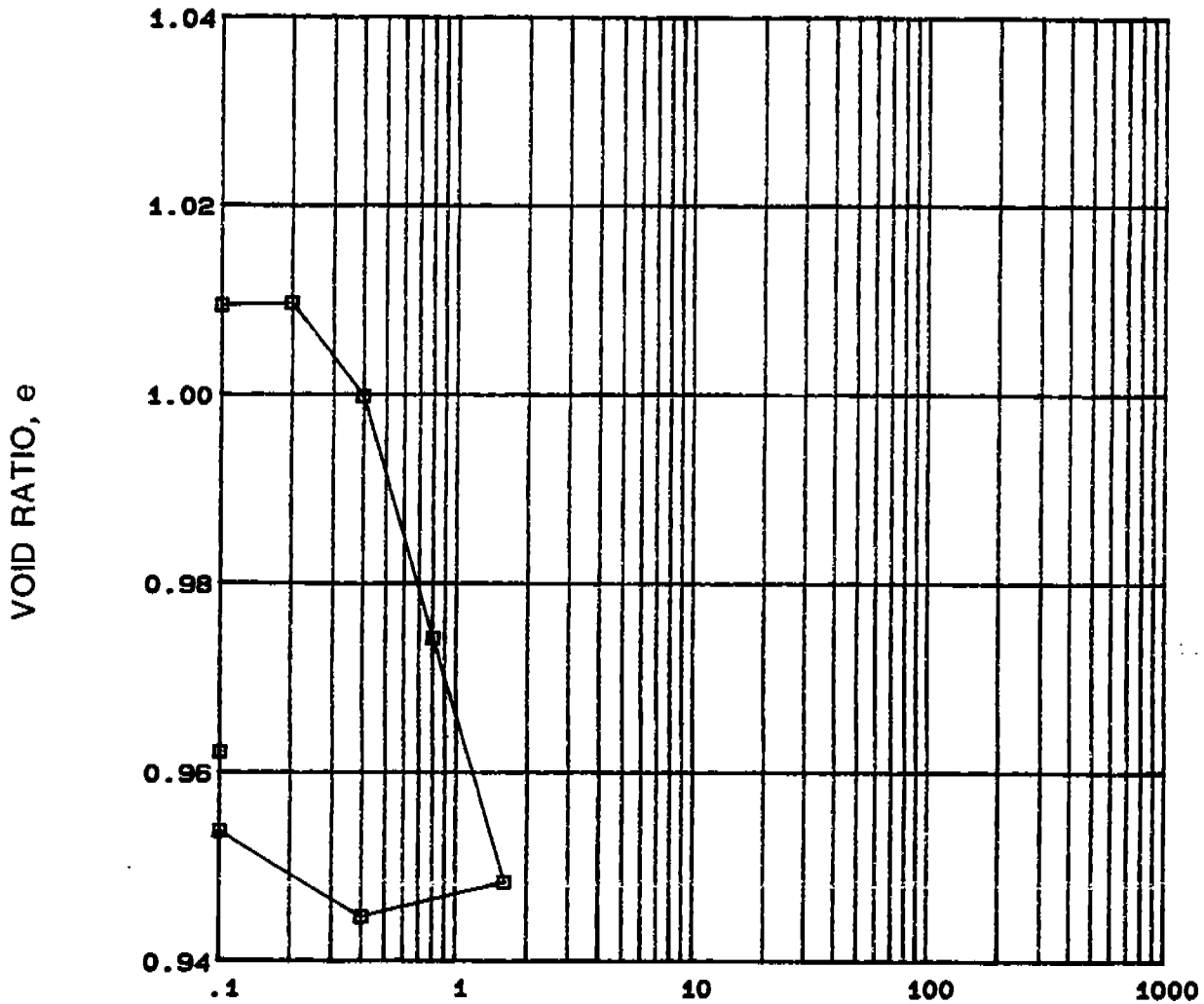

C_v
cm²/sec x 10⁻³

Reference: ASTM D-2435

SPECIMEN TYPE		UNDISTURBED		BEFORE TEST				AFTER TEST	
DIAMETER (in)	2.43	HEIGHT (in)	0.80	MOISTURE CONTENT	w ₀	4.7 %	w _f	24.8 %	
OVERBURDEN PRESSURE, σ _{vo'}		psf		VOID RATIO	e ₀	0.97	e _f	0.95	
PRECONSOL PRESSURE, (σ _{vo'}) _{max}		psf		SATURATION	S ₀	13 %	S _f	70 %	
COMPRESSION INDEX, C _c				DRY DENSITY	γ _d	86 pcf	γ _d	86 pcf	
LIQUID LIMIT		PLASTIC LIMIT		PLASTICITY INDEX			SPECIFIC GRAVITY	2.70	
CLASSIFICATION	BROWN SAND W/SILT (SP-SM)			SOURCE	SB-17-07 @ 4.0 FT				

Consolidation Test Report

PLATE



SOLEA TESTING GROUP

FF

Consolidation Test Report
HLA Laboratory Analysis Routines Ver 3.0

Project Name: HLA-FORT ORD 16/17
Project Number: 23366-4469

Test Date: 04-05-1994
Location: SB-17-08 @ 42.5

Deformation Dial Constant (in/div): 0.0001

Sample Data:

Diameter (in): 2.43 Initial Height (in): 0.80
Dry Weight (g): 94.9 Specific Gravity (g/cc): 2.70
Overburden (psf): Preconsolidation (psf):
LL: -- PL: -- PI: --
Compression Index:
Specimen Type: UNDISTURBED
Soil Classification: BROWN SAND W/SILT (SP-SM)

Test Results:

	Initial	Final
Moisture Content (%):	7.8	20.9
Void Ratio :	0.73	0.69
Saturation (%) :	28.9	81.2
Dry Density (pcf) :	97	99

Data Entry By: FF

File #: 424

Consolidation Test Report
HLA Laboratory Analysis Routines Ver 3.0

Project : HLA-FORT ORD 16/17 ID : 23366-4469 Test Date : 04-05-1994

Data Entry By : FF Location : SB-17-08 @ 42.5 Data File : TEST0424

Load (psf)	Corrected Deformation (div)	Void Ratio
100	35	0.72
100	58	0.72
200	66	0.72
400	70	0.71
800	99	0.71
1600	132	0.70
3200	169	0.69
800	172	0.69
200	168	0.69
100	161	0.69

PRESSURE (ksf)

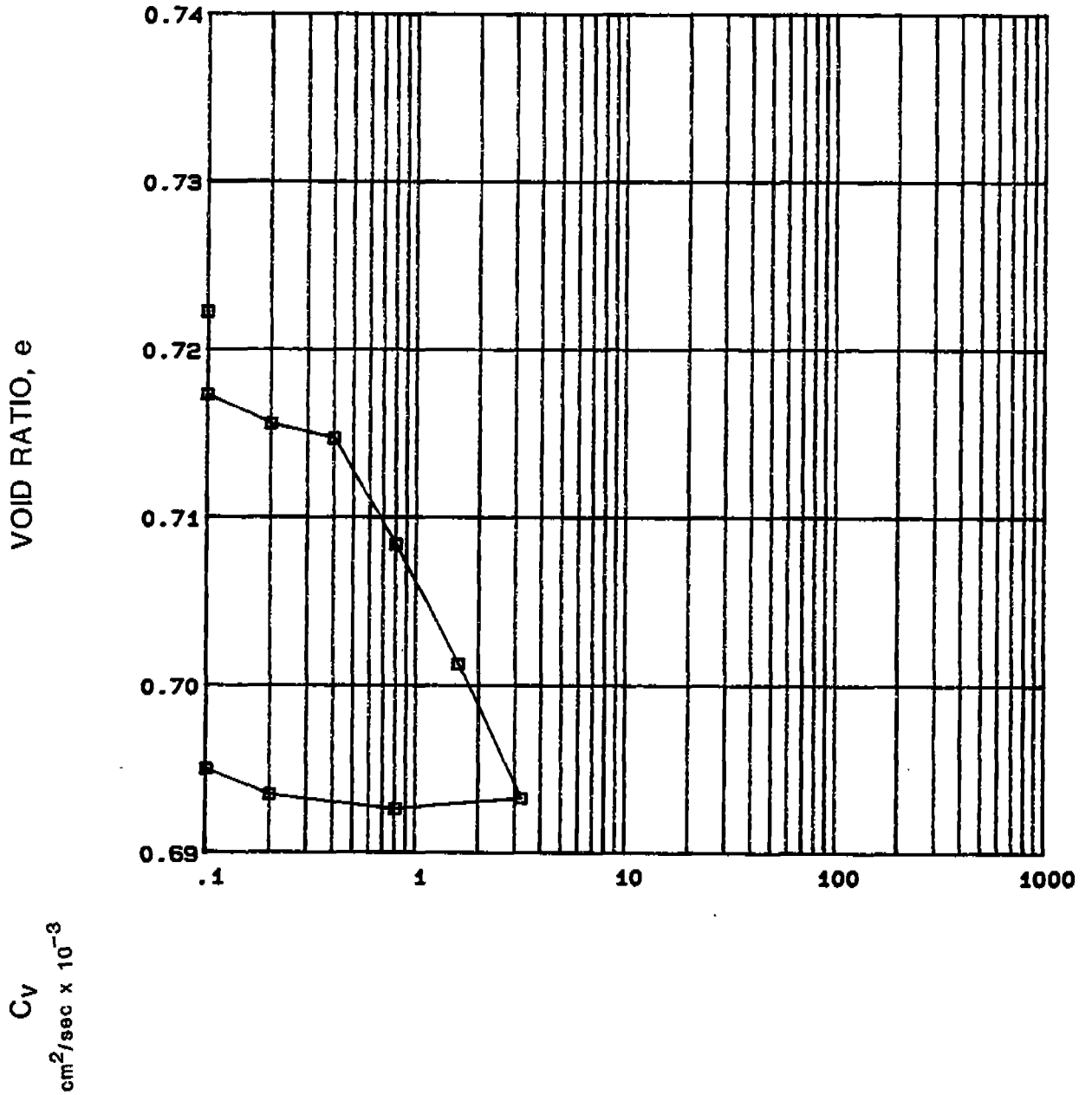

C_v
cm²/sec x 10⁻³

Reference: ASTM D-2435

SPECIMEN TYPE UNDISTURBED		BEFORE TEST				AFTER TEST	
DIAMETER (in)	2.43	HEIGHT (in)	0.60	MOISTURE CONTENT	w_o 7.8 %	w_f 20.9 %	
OVERBURDEN PRESSURE, σ_{vo}'		psf		VOID RATIO	e_o 0.73	e_f 0.69	
PRECONSOL PRESSURE, $(\sigma_{vo}')_{max}$		psf		SATURATION	S_o 29 %	S_f 81 %	
COMPRESSION INDEX, C_c				DRY DENSITY	γ_d 97 pcf	γ_d 99 pcf	
LIQUID LIMIT		PLASTIC LIMIT		PLASTICITY INDEX		SPECIFIC GRAVITY	2.70
CLASSIFICATION BROWN SAND W/SILT (SP-SM)				SOURCE SB-17-08 @ 42.5 FT			

Consolidation Test Report

PLATE



Consolidation Test Report
HLA Laboratory Analysis Routines Ver 3.0

Project Name: HLA-FORT ORD 16/17
Project Number: 23366-4469

Test Date: 04-05-1994
Location: SB-17-11 @ 15.5

Deformation Dial Constant (in/div): 0.0001

Sample Data:

Diameter (in): 2.43 Initial Height (in): 0.80
Dry Weight (g): 99.2 Specific Gravity (g/cc): 2.70
Overburden (psf): Preconsolidation (psf):
LL: -- PL: -- PI: --
Compression Index:
Specimen Type: UNDISTURBED
Soil Classification: BROWN SAND W/SILT (SP-SM)

Test Results:

	Initial	Final
Moisture Content (%):	6.2	19.6
Void Ratio :	0.65	0.60
Saturation (%) :	25.4	91.0
Dry Density (pcf) :	102	107

Data Entry By: FF

File #: 421

Consolidation Test Report
HLA Laboratory Analysis Routines Ver 3.0

Project : HLA-FORT ORD 16/17 ID : 23366-4469 Test Date : 04-05-1994

Data Entry By : FF Location : SB-17-11 @ 15.5 Data File : TEST0421

Load (psf)	Corrected Deformation (div)	Void Ratio
100	21	0.67
100	47	0.67
200	77	0.66
400	149	0.65
800	231	0.63
1600	289	0.62
3200	365	0.60
800	380	0.60
200	356	0.60
100	353	0.60

PRESSURE (ksf)

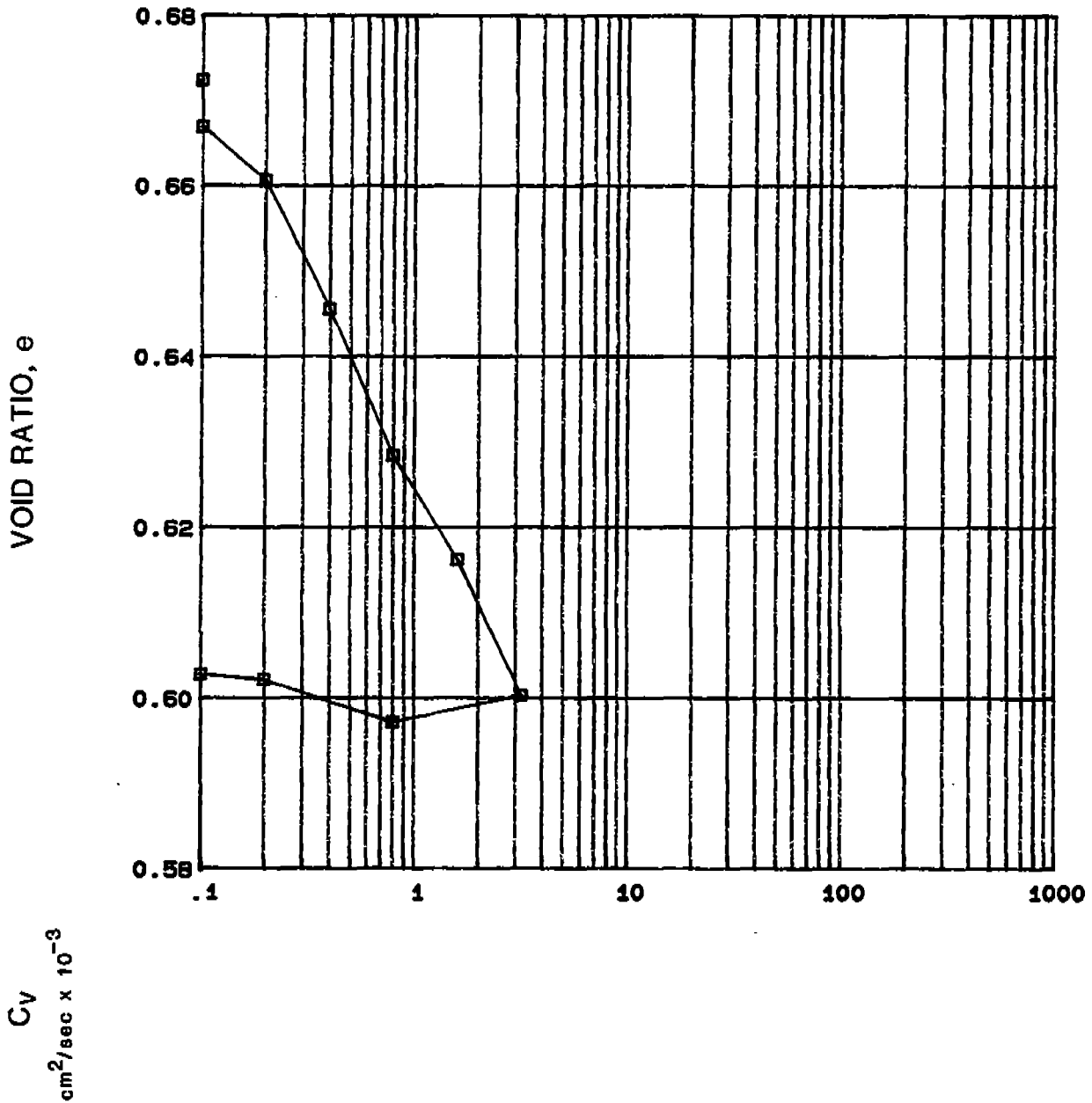

C_v
cm²/sec x 10⁻³

Reference: ASTM D-2435

SPECIMEN TYPE		BEFORE TEST				AFTER TEST		
UNDISTURBED								
DIAMETER (in)	2.43	HEIGHT (in)	0.80	MOISTURE CONTENT	w ₀	6.2 %	w _f	19.6 %
OVERBURDEN PRESSURE, σ_{v0}'		psf		VOID RATIO	e ₀	0.65	e _f	0.60
PRECONSOL PRESSURE, $(\sigma_{v0}')_{max}$		psf		SATURATION	S ₀	25 %	S _f	91 %
COMPRESSION INDEX, C _c				DRY DENSITY	γ_d	102 pcf	γ_d	107 pcf
LIQUID LIMIT	---	PLASTIC LIMIT	---	PLASTICITY INDEX	---	SPECIFIC GRAVITY		2.70
CLASSIFICATION BROWN SAND W/SILT (SP-SM)				SOURCE SB-17-11 @ 15.5 FT				

Consolidation Test Report

PLATE



SOLEA TESTING GROUP

DRAWN

JOB NUMBER

23366-4469

APPROVED

FF

DATE

04-05-1994

REVISED

DATE

Consolidation Test Report
HLA Laboratory Analysis Routines Ver 3.0

Project Name: HLA-FORT ORD 16/17
Project Number: 23366-4469

Test Date: 04-05-1994
Location: SB-17-11 @ 4.0

Deformation Dial Constant (in/div): 0.0001

Sample Data:

Diameter (in):	2.43	Initial Height (in):	0.80
Dry Weight (g):	98.7	Specific Gravity (g/cc):	2.70
Overburden (psf):		Preconsolidation (psf):	
LL: --	PL: --	PI: --	
Compression Index:			
Specimen Type: UNDISTURBED			
Soil Classification: BROWN SAND W/SILT (SP-SM)			

Test Results:

	Initial	Final
Moisture Content (%):	6.1	20.7
Void Ratio :	0.66	0.63
Saturation (%) :	24.8	88.2
Dry Density (pcf) :	101	103

Data Entry By: FF

File #: 422

Consolidation Test Report
HLA Laboratory Analysis Routines Ver 3.0

Project : HLA-FORT ORD 16/17 ID : 23366-4469 Test Date : 04-05-1994

Data Entry By : FF Location : SB-17-11 @ 4.0 Data File : TEST0422

Load (psf)	Corrected Deformation (div)	Void Ratio
100	24	0.66
100	26	0.66
200	25	0.66
400	31	0.66
800	48	0.65
1600	93	0.64
3200	147	0.63
800	142	0.63
200	137	0.63
100	137	0.63

PRESSURE (ksf)

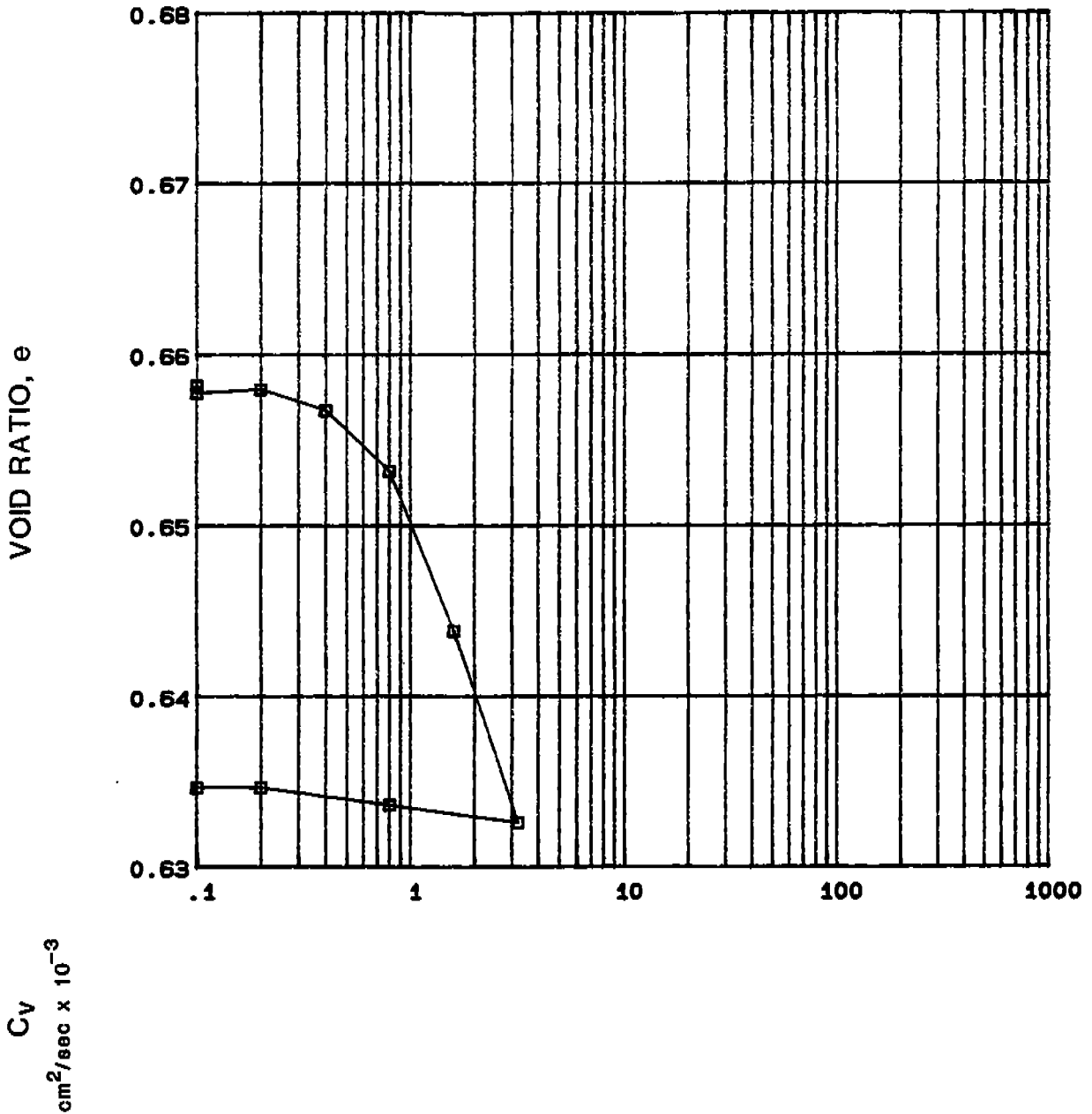

Reference: ASTM D-2435

SPECIMEN TYPE		UNDISTURBED		BEFORE TEST				AFTER TEST	
DIAMETER (in)	2.43	HEIGHT (in)	0.80	MOISTURE CONTENT	w _o	6.1 %	w _f	20.7 %	
OVERBURDEN PRESSURE, σ _{vo} '		psf		VOID RATIO	e _o	0.66	e _f	0.63	
PRECONSOL PRESSURE, (σ _{vo} ') _{max}		psf		SATURATION	S _o	25 %	S _f	88 %	
COMPRESSION INDEX, C _c				DRY DENSITY	γ _d	101 pcf	γ _d	103 pcf	
LIQUID LIMIT		PLASTIC LIMIT		PLASTICITY INDEX			SPECIFIC GRAVITY	2.70	
CLASSIFICATION	BROWN SAND W/SILT (SP-SM)			SOURCE	SB-17-11 @ 4.0 FT				

Consolidation Test Report

PLATE



SOLEA TESTING GROUP

DRAWN

JOB NUMBER
23366-4469

APPROVED

FF

DATE
04-05-1994

REVISED

DATE



FIXED-WALL PERMEABILITY REPORT

PSN
0726

Fallinghead-Risingtail Method (ASTM D-2434)

Project: HLA-Fort Ord Site 16/17

Project No.: HLA.002

LRN: 4469

Sample I.D.:

Boring: SB-16-24

Depth: 18-18.5

Sample Description:

Yellow Brown Sand W/Silt (SP SM)

MOISTURE DATA		Before Test			After Test				
Setup Date:	3/29/94	Julian day:	453	Specimen	Trimings	Misc.	Specimen	Solids	Total
Tare No.:							S-317	J-9	
Wet Soil & Tare Weight:	grams						987.6		
Dry Soil & Tare Weight:	grams						838.7	51.3	
Tare Weight:	grams						133.6	50.9	
Wet Soil Weight:	grams		729.1				854.0		854.5
Dry Soil Weight:	grams		705.50				705.10	0.40	705.50
Water Content:	%		3.35				21.12		21.12

DIMENSIONS	Initial Length (inches)	6.000	Initial Diameter (inches)	2.400	Final Length (inches)	5.900	Final Diameter (inches)	2.400
	Average	6.000	Average	2.400	Average	5.900	Average	2.400

SPECIMEN DATA		Initial	Δ	Saturated	Δ	Consolidated	Δ	Final
Length, Ave.	centimeters	15.240				14.986	= 5.900in	14.986
Diameter, Ave.	centimeters	6.096				5.904		6.096
Area	cm ²	29.186				27.378		29.186
Dial Reading	inches							
Burette Reading	centimeters							
Effective Consolidation Pressure:			Back Pressure:		Burette Area:	0.30 cm ²	C factor:	0.0770

Solids Weight, cc:	Ws	705.50	Gs = 2.70	705.50		705.50		705.50
Volume Total, cc:	Vt	444.80	-34.52	410.28		410.28	27.11	437.39
Volume Solids, cc:	Vs	261.30		261.30		261.30		261.30
Volume Voids, cc:	Vv	183.50		148.98		148.98		176.09
Volume Water, cc:	Vw	23.60		148.98		148.98		148.98

Void Ratio	e	0.702		0.570		0.570		0.674
% Saturation	S	12.86		100.00		100.00		84.61
% Porosity	n	41.23		36.28		36.28		40.23
% Moisture	M	3.35		21.12		21.12		21.12
Dry Density, pcf	γ	99.02		107.35		107.35		100.70

FINAL PERMEABILITY DATA							
Trial	Time, sec	H0, cm	Hf, cm	Gradient Range (i)		Day	K20 cm/sec
1	15	59.7	25.0	2	4		4.5E-3
2	15	60.0	25.3	2	4		4.4E-3
3	15	59.7	25.1	2	4		4.4E-3
4	15	59.9	25.4	2	4		4.4E-3

AVERAGE PERMEABILITY, cm/sec:

4.4E-3

Assumptions & Notes

- 1.) "Initial" data based on initial measured weights and dimensions.
- 2.) "Saturated" data show calculated values, based on 100% saturation. Volume changes are calculated, not measured.
- 3.) "Consolidated" data is based on measured water content and consolidation volume change and the sample is 100% saturated.
- 4.) "Final" data based on measured weights and dimensions on specimen out of the cell which may allow change in water content and volume.
- 5.) Permeant type: 0.005N Solution of CaSO4.
- 6.) Notes:

SOLEA

SOLEA TESTING GROUP

FIXED-WALL PERMEABILITY REPORT

Fallinghead-Risingtail Method (ASTM D-2434)

PSN

0724

Project: HLA-Fort Ord Site 16/17

Project No.: HLA.002

LRN: 4469

Sample I.D.:

Boring: SB-16-26

Depth: 16-16.5

Sample Description:

Olive Brown Sand W/silt (SP-SM)

MOISTURE DATA		Before Test			After Test				
Setup Date:	3/30/94	Julian day	454	Specimen	Trimming	Misc.	Specimen	Solids	Total
Tare No.							AC-5	C-3	
Wet Soil & Tare Weight	grams						832.5		
Dry Soil & Tare Weight	grams						701.3	54.4	
Tare Weight	grams						122.5	53.1	
Wet Soil Weight	grams		596.5				710.0		711.6
Dry Soil Weight	grams		580.10				578.80	1.30	580.10
Water Content	%		2.83				22.67		22.67

DIMENSIONS	Initial Length (inches)	5.200	Initial Diameter (inches)	2.400	Final Length (inches)	5.050	Final Diameter (inches)	2.400
	Average	5.200	Average	2.400	Average	5.050	Average	2.400

SPECIMEN DATA		Initial	Δ	Saturated	Δ	Consolidated	Δ	Final
Length, Ave.	centimeters	13.208				12.827	=5.050in.	12.827
Diameter, Ave.	centimeters	6.096				5.863		6.096
Area	cm ²	29.186				27.001		29.186
Dial Reading	inches							
Burette Reading	centimeters							
Effective Consolidation Pressure			Back Pressure		Burette Area	0.30 cm ²	C factor	0.0659

Solids Weight, cc	Ws	580.10	Gs = 2.70	580.10		580.10		580.10
Volume Total, cc	Vt	385.49	-39.15	346.35		346.35	28.03	374.37
Volume Solids, cc	Vs	214.85		214.85		214.85		214.85
Volume Voids, cc	Vv	170.64		131.49		131.49		159.52
Volume Water, cc	Vw	16.40		131.49		131.49		131.49

Void Ratio	e	0.794		0.612		0.612		0.742
% Saturation	S	9.61		100.00		100.00		82.43
% Porosity	n	44.24		37.94		37.94		42.58
% Moisture	M	2.83		22.67		22.67		22.67
Dry Density, pcf	γ	93.95		104.56		104.56		96.74

FINAL PERMEABILITY DATA

Trial	Time, sec	H ₀ , cm	H _f , cm	Gradient Range (l)		Day	K ₂₀ cm/sec
1	15	59.5	23.2	2	5		4.1E-3
2	15	59.6	23.0	2	5		4.2E-3
3	15	59.8	23.3	2	5		4.1E-3
4	15	59.5	23.3	2	5		4.1E-3

AVERAGE PERMEABILITY, cm/sec:

4.1E-3

Assumptions & Notes

- "Initial" data based on initial measured weights and dimensions.
- "Saturated" data show calculated values, based on 100% saturation. Volume changes are calculated, not measured.
- "Consolidated" data is based on measured water content and consolidation volume change and the sample is 100% saturated.
- "Final" data based on measured weights and dimensions on specimen out of the cell which may allow change in water content and volume.
- Permeant type: 0.005N Solution of CaSO₄.
- Notes:

k-check3.xls (E) rev. 9/27/92

LF-H170c

DRAWN

DATE

APPROVED

PAGE

4/5/94

FF

4



FIXED-WALL PERMEABILITY REPORT

PSN
0723

Fallinghead-Risingtail Method (ASTM D-2434)

Project: HLA-Fort Ord Site16/17 Project No.: HLA.002 LRN: 4469

Sample I.D.: Boring: SB-17-07 Depth: 21-21.5

Sample Description: Olive-Brown Sand w/ Silt (SP-SM)

MOISTURE DATA		Before Test			After Test		
Setup Date:	3/31/94	Specimen	Trimmings	Misc.	Specimen	Solids	Total
Tare No.:	julian day 455				CC	D-59	
Wet Soil & Tare Weight:	grams				832.3		
Dry Soil & Tare Weight:	grams				684.2	60.8	
Tare Weight:	grams				107.6	40.8	
Wet Soil Weight:	grams	617.0			724.7		749.8
Dry Soil Weight:	grams	596.60			576.60	20.00	596.60
Water Content:	%	3.42			25.69		25.69

DIMENSIONS	Initial Length (inches)	5.250	Initial Diameter (inches)	2.400	Final Length (inches)	5.150	Final Diameter (inches)	2.400
	Average	5.250	Average	2.400	Average	5.150	Average	2.400

SPECIMEN DATA		Initial	Δ	Saturated	Δ	Consolidated	Δ	Final
Length, Ave.	centimeters	13.335				13.081	=5.150in.	13.081
Diameter, Ave.	centimeters	6.096				6.035		6.096
Area	cm ²	29.186				28.606		29.186
Dial Reading	inches							
Burette Reading	centimeters							
Effective Consolidation Pressure:			Back Pressure		Burette Area:	0.30 cm ²	C factor:	0.0672

Solids Weight, cc:	Ws	596.60	Gs = 2.70	596.60		596.60		596.60
Volume Total, cc:	Vt	389.20	-15.00	374.20		374.20	7.59	381.79
Volume Solids, cc:	Vs	220.96		220.96		220.96		220.96
Volume Voids, cc:	Vv	168.24		153.24		153.24		160.82
Volume Water, cc:	Vw	20.40		153.24		153.24		153.24

Void Ratio	e	0.761		0.693		0.693		0.728
% Saturation	S	12.13		100.00		100.00		95.28
% Porosity	n	43.20		40.92		40.92		42.10
% Moisture	M	3.42		25.69		25.69		25.69
Dry Density, pcf	γ	95.70		99.53		99.53		97.56

FINAL PERMEABILITY DATA							
Total	Time, sec	Ho, cm	Hf, cm	Gradient Range (ft)		Day	K20 cm/sec
1	15	60.6	18.9	1	5		5.2E-3
2	15	60.9	20.0	2	5		5.0E-3
3	15	61.6	19.5	1	5		5.2E-3
4	15	61.2	19.7	2	5		5.1E-3

AVERAGE PERMEABILITY, cm/sec: **5.1E-3**

- Assumptions & Notes**
- 1.) "Initial" data based on initial measured weights and dimensions.
 - 2.) "Saturated" data show calculated values, based on 100% saturation. Volume changes are calculated, not measured.
 - 3.) "Consolidated" data is based on measured water content and consolidation volume change and the sample is 100% saturated.
 - 4.) "Final" data based on measured weights and dimensions on specimen out of the cell which may allow change in water content and volume.
 - 5.) Permeant type: 0.005N Solution of CaSO4.
 - 6.) Notes:

SOLEA

SOLEA TESTING GROUP

FIXED-WALL PERMEABILITY REPORT

Fallinghead-Risingtail Method (ASTM D-2434)

PSN

0725

Project: HLA-Fort Ord Site 16/17

Project No.: HLA.002

LRN: 4469

Sample I.D.:

Boring: SB-17-08

Depth: 31.5-32

Sample Description:

Brown Silty Sand (SM)

MOISTURE DATA		Before Test			After Test		
Setup Date:	3/29/94	Julian day:	453	Specimen	Trimming	Misc.	Total
Tare No.:							
Wet Soil & Tare Weight:	grams					975.3	
Dry Soil & Tare Weight:	grams					859.4	51.4
Tare Weight:	grams					125.3	51.3
Wet Soil Weight:	grams	812.5				850.0	850.1
Dry Soil Weight:	grams	734.20				734.10	0.10
Water Content:	%	10.66				15.79	15.79

DIMENSIONS	Initial Length (inches)	5.700	Initial Diameter (inches)	2.400	Final Length (inches)	5.600	Final Diameter (inches)	2.400
	Average	5.700	Average	2.400	Average	5.600	Average	2.400

SPECIMEN DATA		Initial	Δ	Saturated	Δ	Consolidated	Δ	Final
Length, Ave.	centimeters	14.478				14.224	5.600in	14.224
Diameter, Ave.	centimeters	6.096				5.892		6.096
Area	cm ²	29.186				27.267		29.186
Dial Reading	inches							
Burette Reading	centimeters							
Effective Consolidation Pressure:			Back Pressure		Burette Area:	0.30 cm ²	C factor:	0.0731

Solids Weight, cc:	Ws	734.20	Gs = 2.70	734.20		734.20		734.20
Volume Total, cc:	Vt	422.56	-34.72	387.84		387.84	27.30	415.15
Volume Solids, cc:	Vs	271.93		271.93		271.93		271.93
Volume Voids, cc:	Vv	150.63		115.92		115.92		143.22
Volume Water, cc:	Vw	78.30		115.92		115.92		115.92

Void Ratio	e	0.554		0.426		0.426		0.527
% Saturation	S	51.98		100.00		100.00		80.94
% Porosity	n	35.62		29.85		29.85		34.47
% Moisture	M	10.66		15.79		15.79		15.79
Dry Density, pcf	γ	108.47		118.18		118.18		110.41

FINAL PERMEABILITY DATA

Trial	Time, sec.	H ₀ , cm	H _f , cm	Gradient	Range (t)	Day	K ₂₀ cm/sec
1	180	60.0	22.3	2	4		4.0E-4
2	180	59.8	22.6	2	4		4.0E-4
3	180	59.4	22.1	2	4		4.0E-4
4	180	60.1	22.4	2	4		4.0E-4

AVERAGE PERMEABILITY, cm/sec:

4.0E-4

Assumptions & Notes

- "Initial" data based on initial measured weights and dimensions.
- "Saturated" data show calculated values, based on 100% saturation. Volume changes are calculated, not measured.
- "Consolidated" data is based on measured water content and consolidation volume change and the sample is 100% saturated.
- "Final" data based on measured weights and dimensions on specimen out of the cell which may allow change in water content and volume.
- Permeant type: 0.005N Solution of CaSO₄.
- Notes:

K-08063.215 (C) Rev. 8/27/92

LF-H170c

DRAWN

DATE

APPROVED

PAGE

4/5/94

FF

4



FIXED-WALL PERMEABILITY REPORT

PSN
0722

Fallinghead-Risingtail Method (ASTM D-2434)

Project: HLA-Fort Ord Site16/17

Project No.: HLA.002

LRN: 4469

Sample I.D.:

Boring: SB-17-11

Depth: 20.5-21

Sample Description:

Brown Sand w/ Silt (SP-SM)

MOISTURE DATA			Before Test			After Test		
Setup Date:	3/31/94	Julian day: 455	Specimen	Trimming	Misc.	Specimen	Solids	Total
Tare No.:						GG	D-58	
Wet Soil & Tare Weight:	grams					947.1		
Dry Soil & Tare Weight:	grams					816.8	41.4	
Tare Weight:	grams					105.3	40.4	
Wet Soil Weight:	grams		754.1			841.8		843.0
Dry Soil Weight:	grams		712.50			711.50	1.00	712.50
Water Content:	%		5.84			18.31		18.31

DIMENSIONS	Initial Length (inches)	5.950	Initial Diameter (inches)	2.400	Final Length (inches)	5.850	Final Diameter (inches)	2.400
	Average	5.950	Average	2.400	Average	5.850	Average	2.400

SPECIMEN DATA		Initial	Δ	Saturated	Δ	Consolidated	Δ	Final
Length, Ave.	centimeters	15.113				14.859	$\approx 5.850 \text{ in}$	14.859
Diameter, Ave.	centimeters	6.096				5.813		6.096
Area	cm ²	29.186				26.541		29.186
Dial Reading	inches							
Burette Reading:	centimeters							
Effective Consolidation Pressure:			Back Pressure		Burette Area: 0.30 cm ²		C factor: 0.0764	

Solids Weight, cc:	V_s	712.50	$G_s = 2.70$	712.50		712.50		712.50
Volume Total, cc:	V_t	441.09	-46.72	394.37		394.37	39.31	433.68
Volume Solids, cc:	V_s	263.89		263.89		263.89		263.89
Volume Voids, cc:	V_v	177.20		130.48		130.48		169.79
Volume Water, cc:	V_w	41.60		130.48		130.48		130.48

Void Ratio	e	0.672		0.494		0.494		0.643
% Saturation	S	23.48		100.00		100.00		76.85
% Porosity	n	40.15		33.05		33.05		39.12
% Moisture	M	5.84		18.31		18.31		18.31
Dry Density, pci	γ	100.84		112.79		112.79		102.57

FINAL PERMEABILITY DATA							
Trial	Time, sec.	H_0 , cm	H_f , cm	Gradient Range (i)		Day	K_{20} cm/sec
1	30	59.6	21.5	1	4		2.6E-3
2	30	59.4	21.8	1	4		2.6E-3
3	30	58.8	21.5	1	4		2.6E-3
4	30	59.3	21.8	1	4		2.5E-3

AVERAGE PERMEABILITY, cm/sec:

2.6E-3

Assumptions & Notes

- 1.) "Initial" data based on initial measured weights and dimensions.
- 2.) "Saturated" data show calculated values, based on 100% saturation. Volume changes are calculated, not measured.
- 3.) "Consolidated" data is based on measured water content and consolidation volume change and the sample is 100% saturated.
- 4.) "Final" data based on measured weights and dimensions on specimen out of the cell which may allow change in water content and volume.
- 5.) Permeant type: 0.005N Solution of CaSO₄.
- 6.) Notes:



R-VALUE TEST WORKSHEET

PROJECT NO 23366-01724 LAB NO. 3193 TECH: LS/SH DATE: 4-4-94

SALSA ELA-FORT ORD SITE 14/17

TEST SPECIMEN					
MOLD NO.					
Foot Pressure, psi					
Initial Moisture, %		4.0	4.0	4.0	
Initial "As-Is" Sample Weight		1200	1200	1200	1200
Initial Dry Sample Weight		1154	1154	1154	
Water Added, ml		+50	+100	+70	
Water Added, %					
Moisture at Compaction, %		8.3	12.7	10.1	
Height of Briquette, in.		2.56	2.73	2.42	
Wet Weight of Briquette + Mold		3134	3272	3124	
Tare Weight Mold		2081x	2092	2104x	
Wet Weight Briquette		1053	1180	1020	
Dry Density, lbs/cu. ft.		115.1	116.2	116.0	
Stabilometer	1000 lbs.	14	18	12	75
	2000 lbs.	25	35	22	
Displacement		4.08	4.20	4.77	
Exudation Pressure, lbs.		18000	1260	4850	
Exudation Pressure, psi		800	100	390	
R-Value		77 A	68 A	77 A	
Dial Reading, End		78	72	76	
Dial Reading, Start					
Difference		0	0	0	
Expansion Pressure, psf		0	0	0	

INITIAL MOISTURE

Pan No. MUD
 Wet Sample + Pan 1200
 Dry Sample + Pan 1154
 Weight of Water _____
 Tare Weight Pan _____
 Weight Dry Sample _____
 Moisture Content, % 4.0

REMARKS: BRN SA

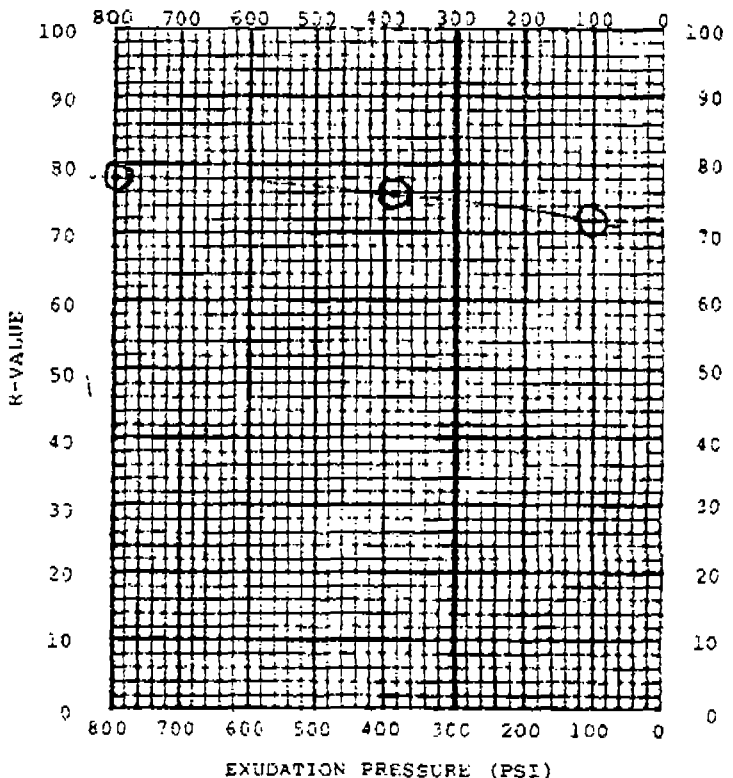

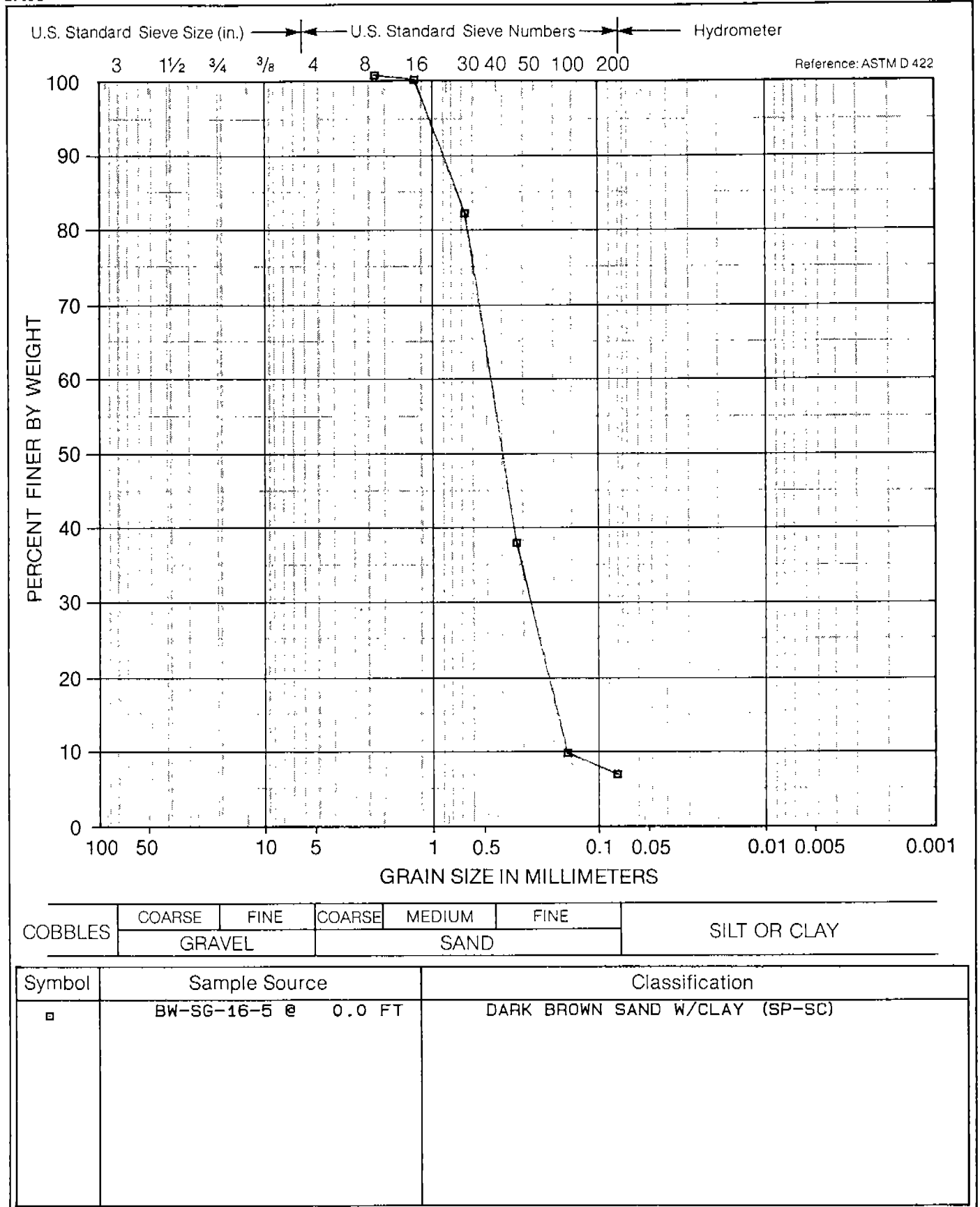

Harding Lawson Associates
 Engineers, Geologists
 & Geophysicists

Particle Size Analysis - Station OF-16-05
 Basewide Surface Water Outfall Investigation
 Remedial Investigation/ Feasibility Study
 Fort Ord, California

PLATE

B10

DRAWN

JOB NUMBER
 07579.534.02

APPROVED

DATE
 04-23-1992

REVISED

DATE

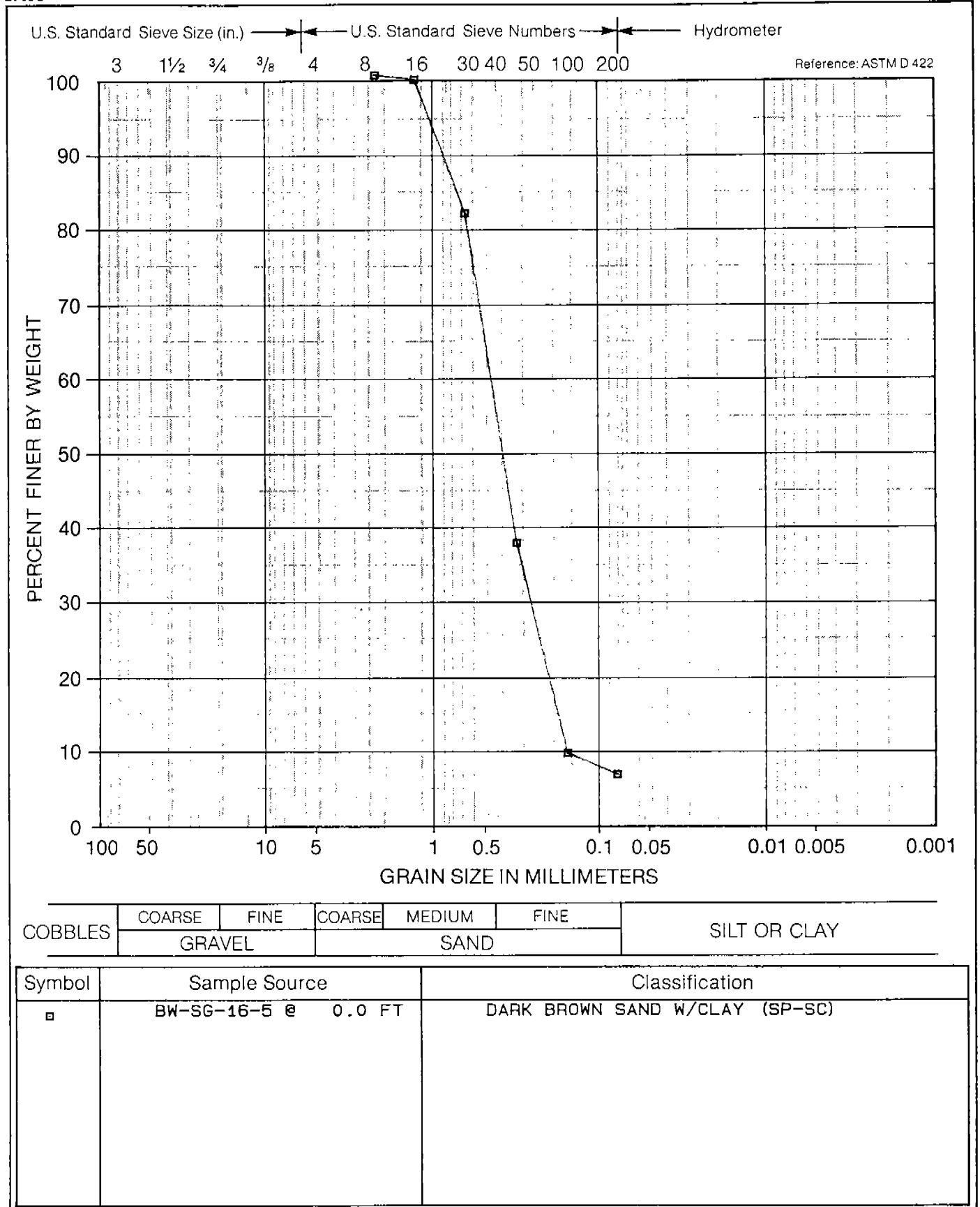

Harding Lawson Associates
 Engineers, Geologists
 & Geophysicists

Particle Size Analysis - Station OF-16-05
 Basewide Surface Water Outfall Investigation
 Remedial Investigation/ Feasibility Study
 Fort Ord, California

PLATE

B10

DRAWN

JOB NUMBER
 07579.534.02

APPROVED

DATE
 04-23-1992

REVISED

DATE

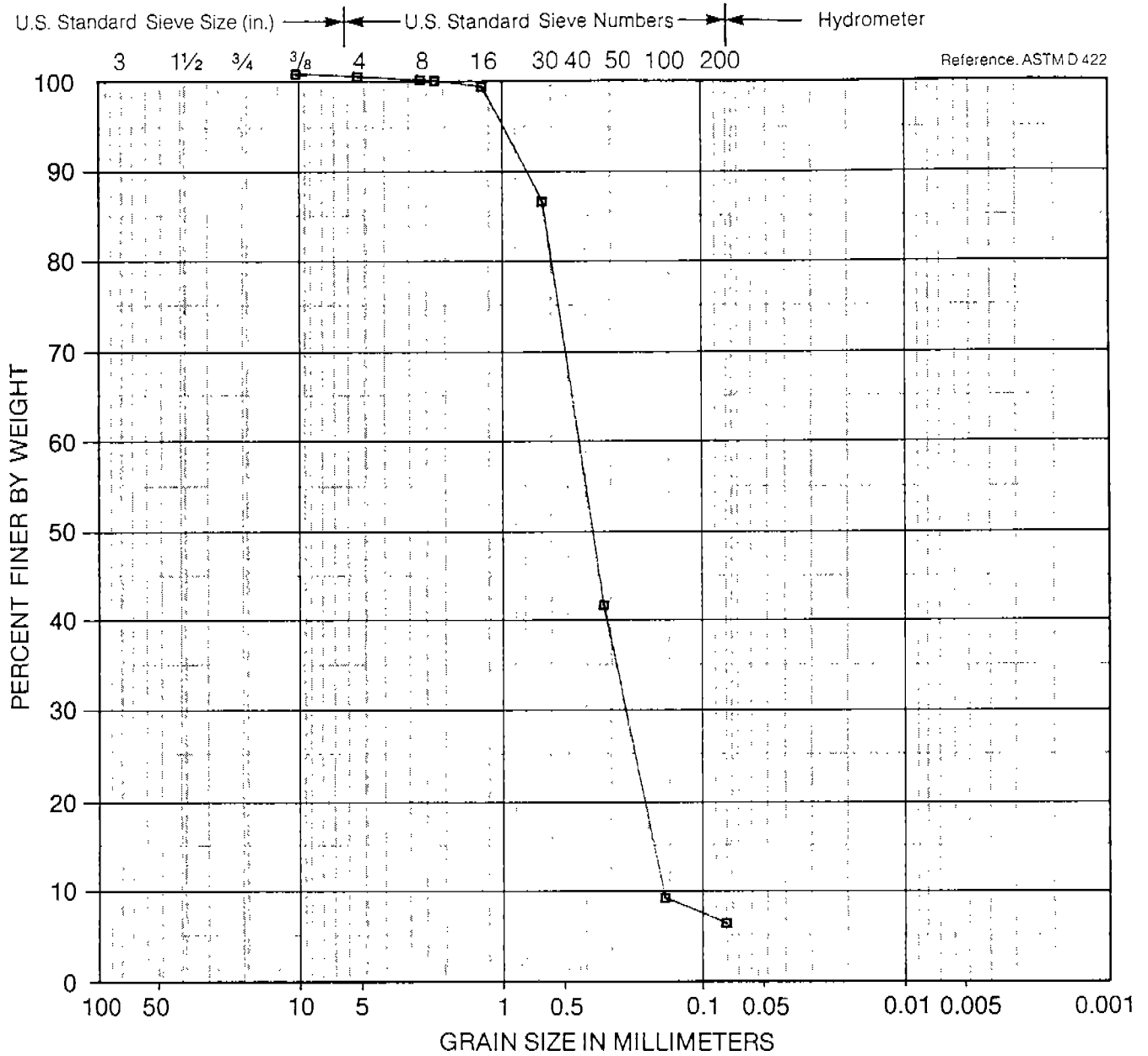

COBBLES	COARSE	FINE	COARSE	MEDIUM	FINE	SILT OR CLAY
	GRAVEL		SAND			

Symbol	Sample Source	Classification
□	BW-SG-16-6 @ 0.0 FT	DARK BROWN SAND W/CLAY (SP-SC)



Harding Lawson Associates
 Engineers, Geologists
 & Geophysicists

Particle Size Analysis - Station OF-16-06
 Basewide Surface Water Outfall Investigation
 Remedial Investigation/ Feasibility Study
 Fort Ord, California

PLATE

B11

DRAWN

JOB NUMBER
 07579.534.02

APPROVED

DATE
 04-23-1992

REVISED

DATE

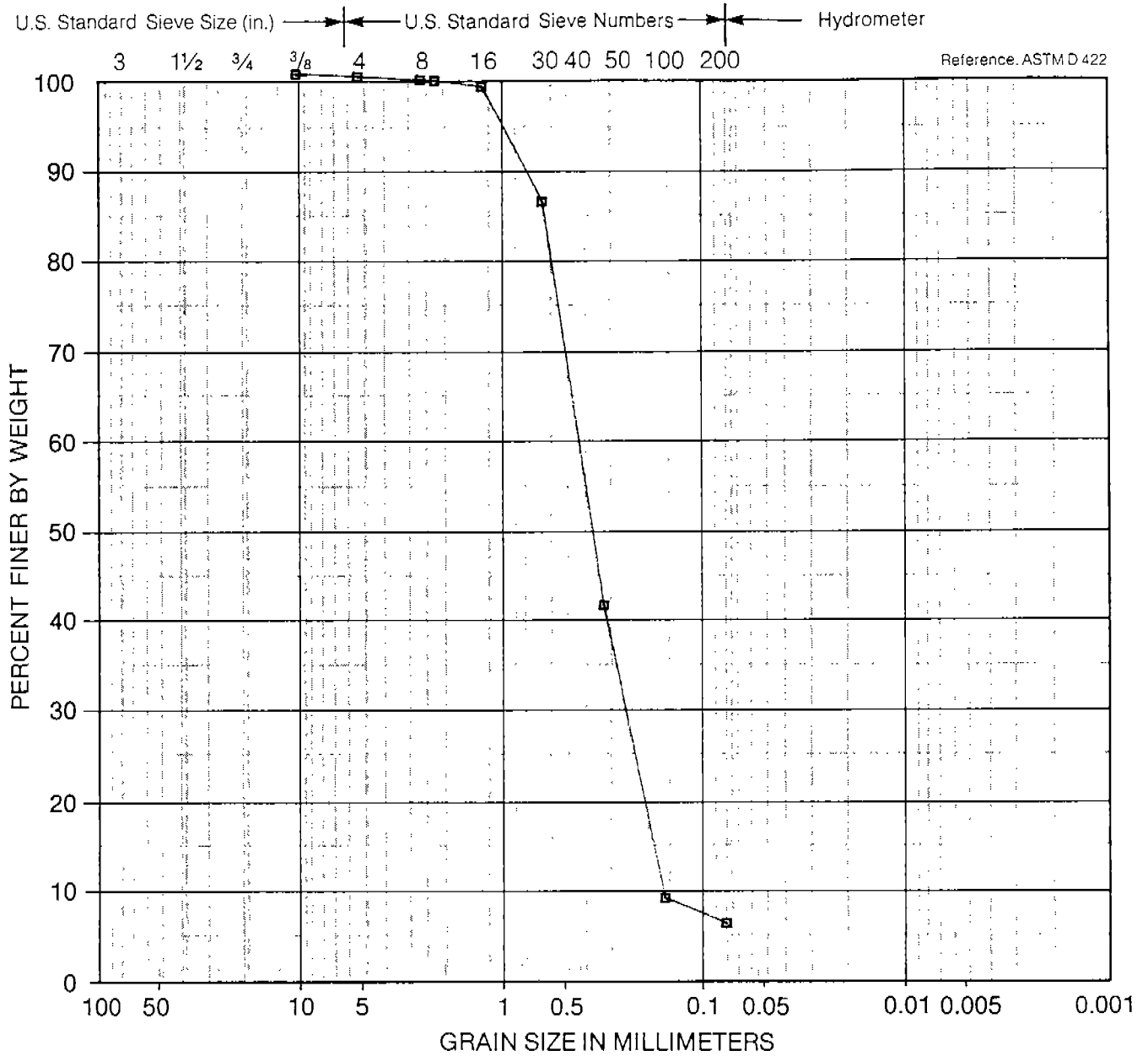

COBBLES	COARSE	FINE	COARSE	MEDIUM	FINE	SILT OR CLAY
	GRAVEL		SAND			

Symbol	Sample Source	Classification
□	BW-SG-16-6 @ 0.0 FT	DARK BROWN SAND W/CLAY (SP-SC)



Harding Lawson Associates
 Engineers, Geologists
 & Geophysicists

Particle Size Analysis - Station OF-16-06
 Basewide Surface Water Outfall Investigation
 Remedial Investigation/ Feasibility Study
 Fort Ord, California

PLATE

B11

DRAWN

JOB NUMBER
 07579.534.02

APPROVED

DATE
 04-23-1992

REVISED

DATE

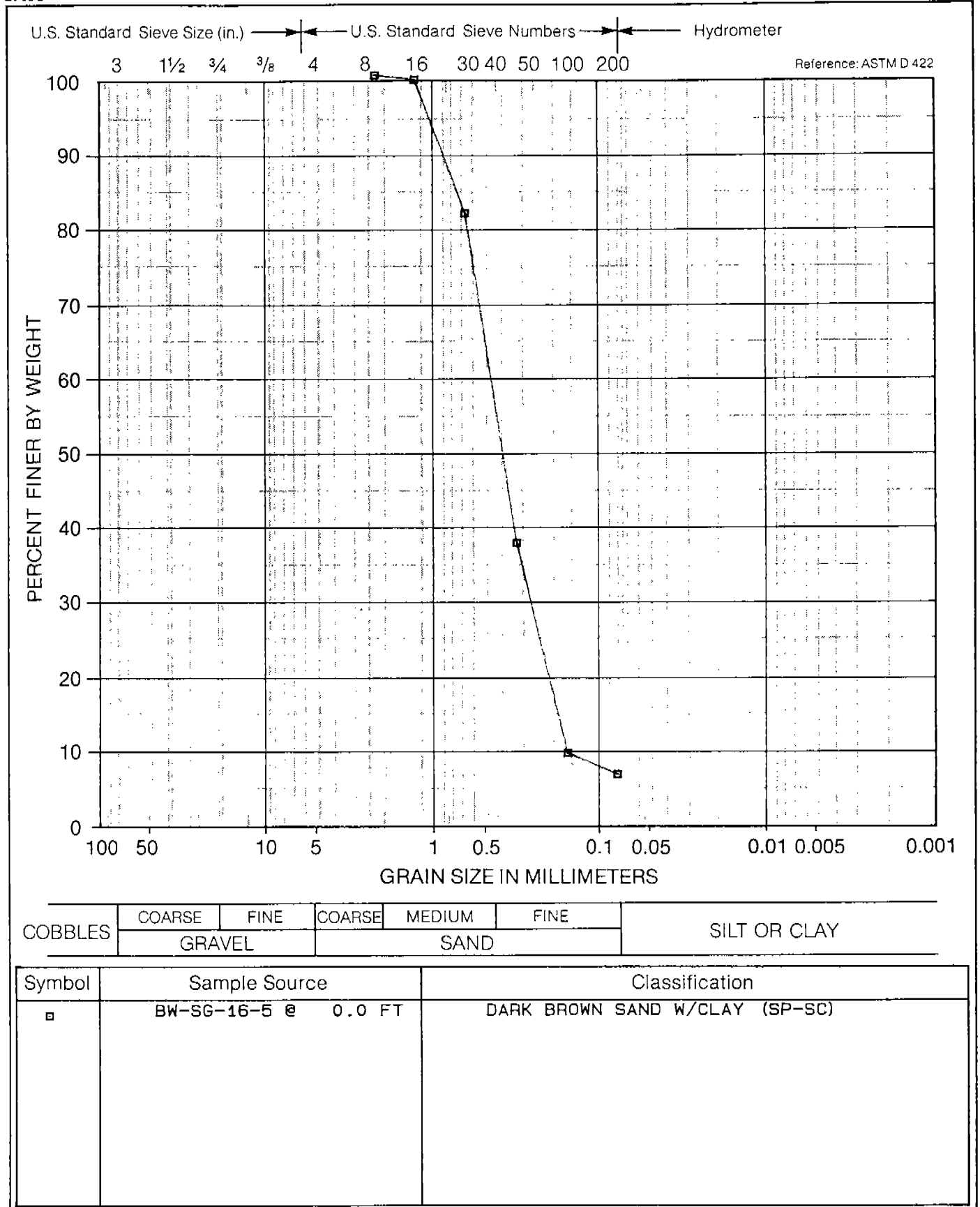

Harding Lawson Associates
 Engineers, Geologists
 & Geophysicists

Particle Size Analysis - Station OF-16-05
 Basewide Surface Water Outfall Investigation
 Remedial Investigation/ Feasibility Study
 Fort Ord, California

PLATE

B10

DRAWN

JOB NUMBER
 07579.534.02

APPROVED

DATE
 04-23-1992

REVISED

DATE

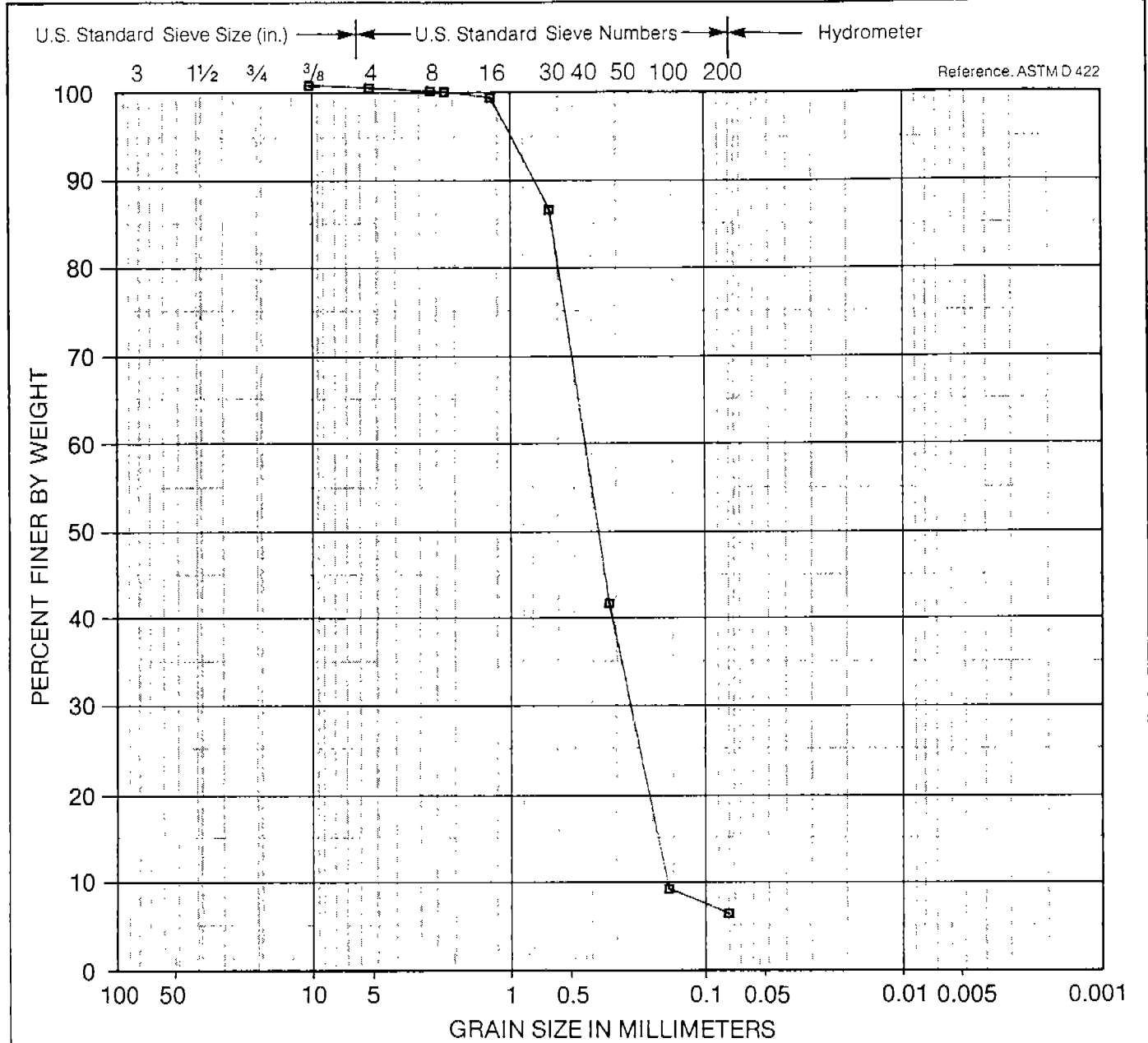

Site 18^{1,2}

¹ Please see Figure 5 for full citation.

² Boring logs for Site 18 could not be located. Location map included for reference.

EXPLANATION

- SB-18-05 ◆ SOIL BORING LOCATION
- SB-18 ◆ SOIL BORING (JMM)
- MW-18-07-100 ◆ MONITORING WELL (JMM)

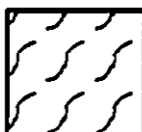
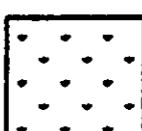
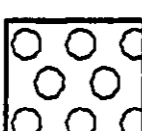
-  FULLY DEVELOPED
-  UPLAND RUDERAL
-  LANDSCAPED
-  COAST LIVE OAK WOODLAND

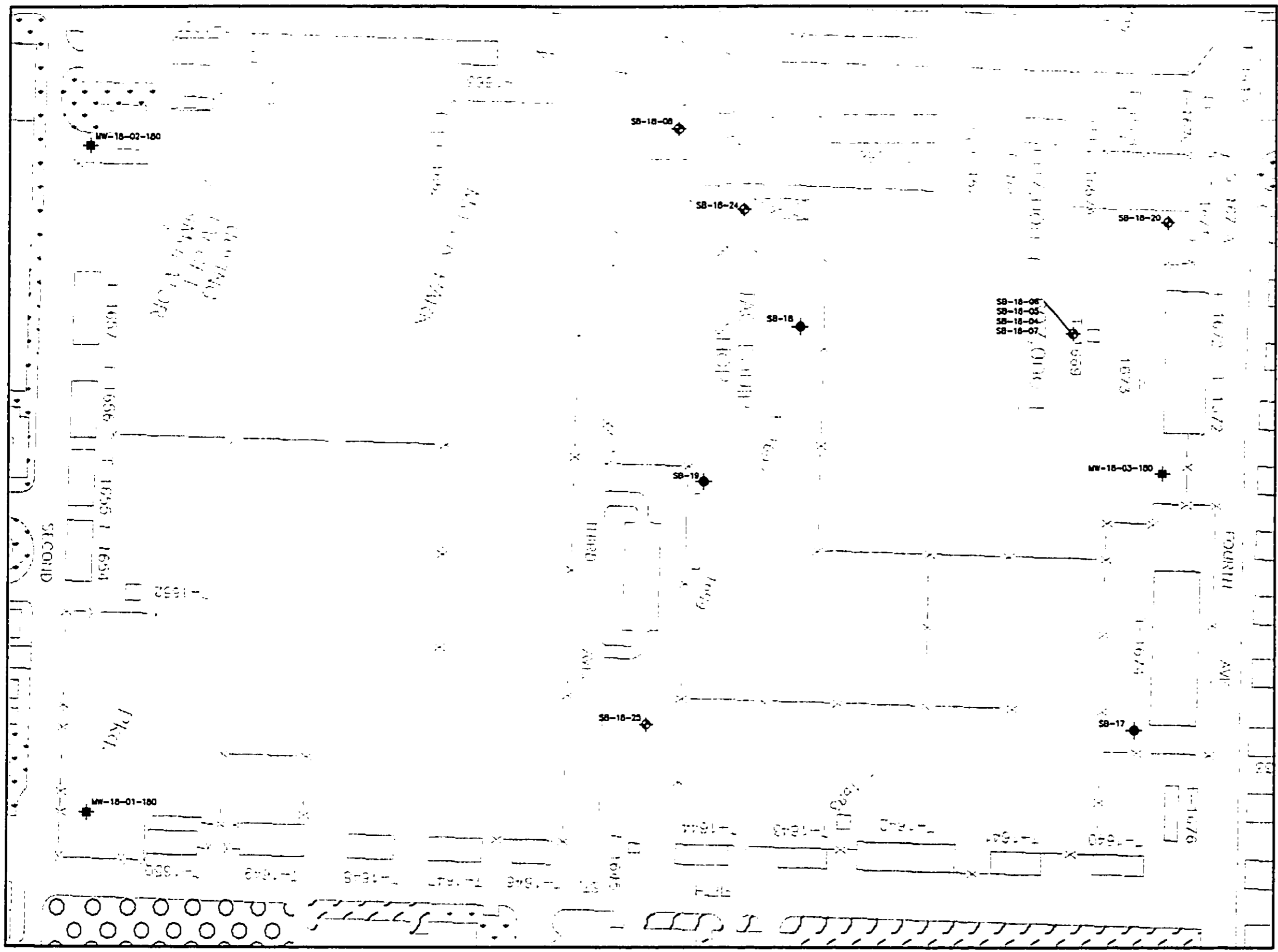
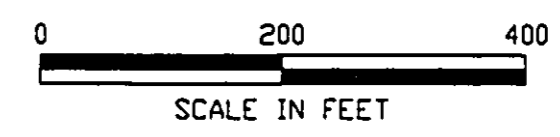

If this image is not as legible as this overlay, it's due to the poor quality of the original document

23366056 2008 19940301.S50

NO.	DATE	REVISIONS	HLA FILE NO.	PROJECT NO.	APPROVED	APPROVAL DATE	DRAWN BY	 Harding Lawson Associates Engineering and Environmental Services	Volume IV - Ecological Risk Assessment Basewide RI/FS Fort Ord, California	Plant Communities and Sampling Locations Site 18 - 1600 Block Facility	PLATE: 3.9
1	7/11/94	DRAFT	23366295	23366 041714			PH				
2	12/94	DRAFT FINAL	23366295	23366 041724	<i>[Signature]</i>	11/17/94	PH				

Site 25¹

¹ Please see Figure 5 for full citation.

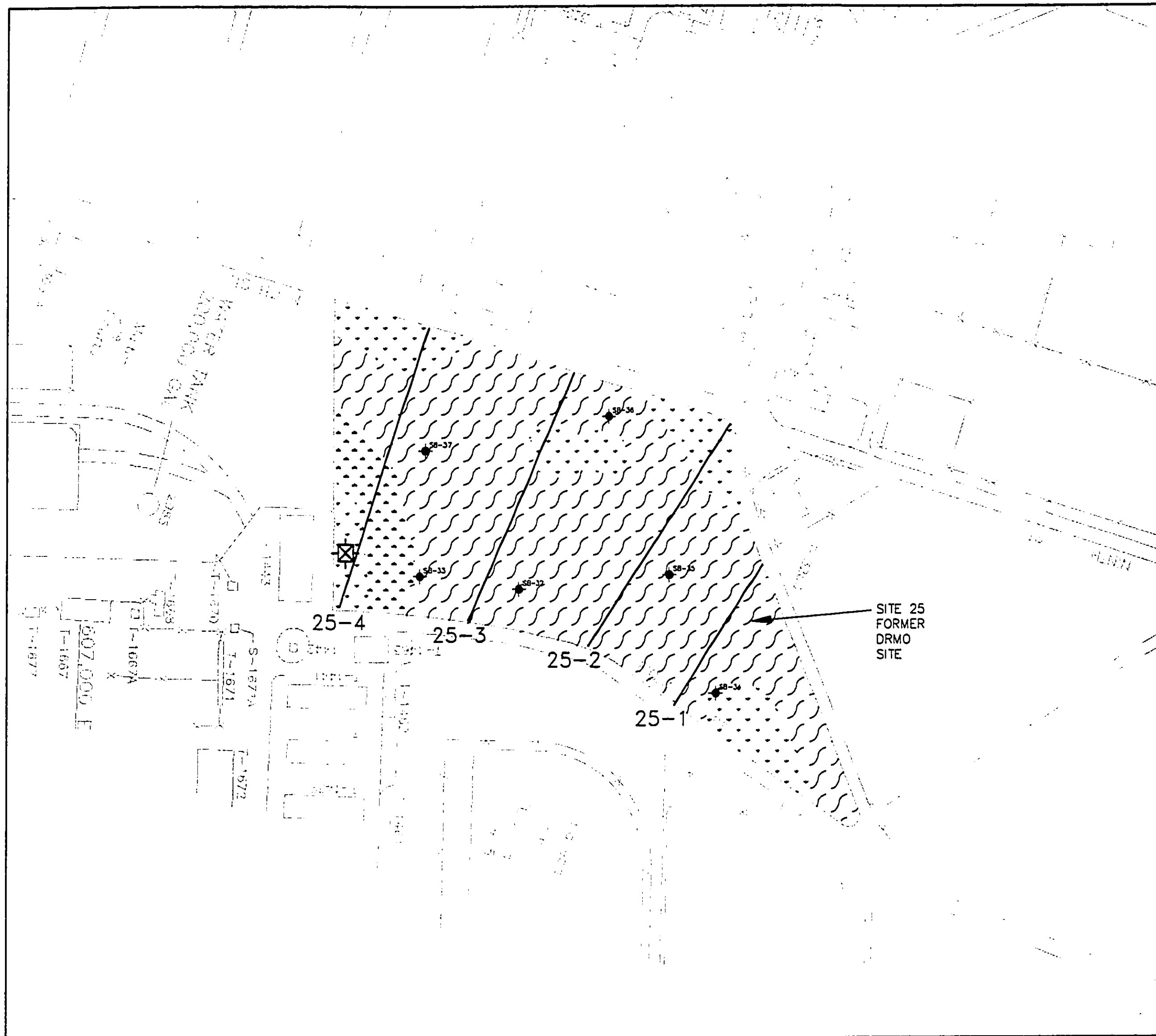

EXPLANATION

- SOIL BORING LOCATION (JMM)
- RODENT COLLECTION

- FULLY DEVELOPED/NOT SURVEYED
- UPLAND RUDERAL
- LANDSCAPED
- CENTRAL MARITIME CHAPARRAL

25-1 — BIOTA SAMPLING TRANSECT (OAT/ICEPLANT, SOIL, RODENT, LITTER)

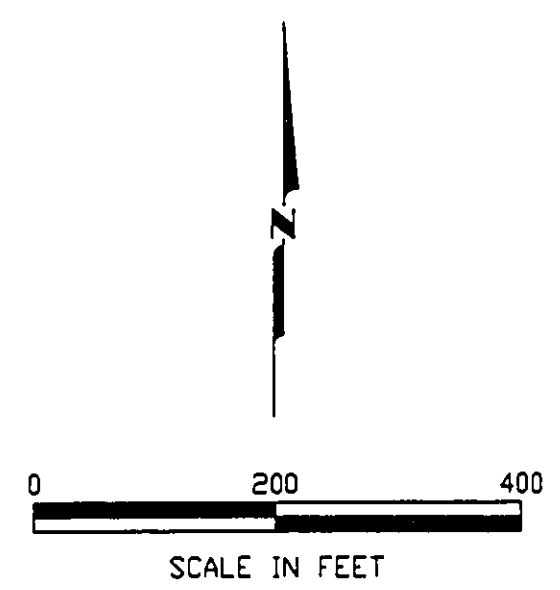

If this image is not as legible as this overlay, it's due to the poor quality of the original document

NO.	DATE	REVISIONS	HLA FILE NO.	PROJECT NO.	APPROVED	APPROVAL DATE	DRAWN BY				PLATE
1	7/12/94	DRAFT	23366302	23366 041714			AED	Harding Lawson Associates Engineering and Environmental Services	Volume IV - Ecological Risk Assessment Basewide RI/FS Fort Ord, California	Plant Communities and Sampling Locations Site 25 - Former DRMO	4.13
2	12/94	DRAFT FINAL	23366302	23366 041724	<i>HLA</i>	11/17/88	PH				

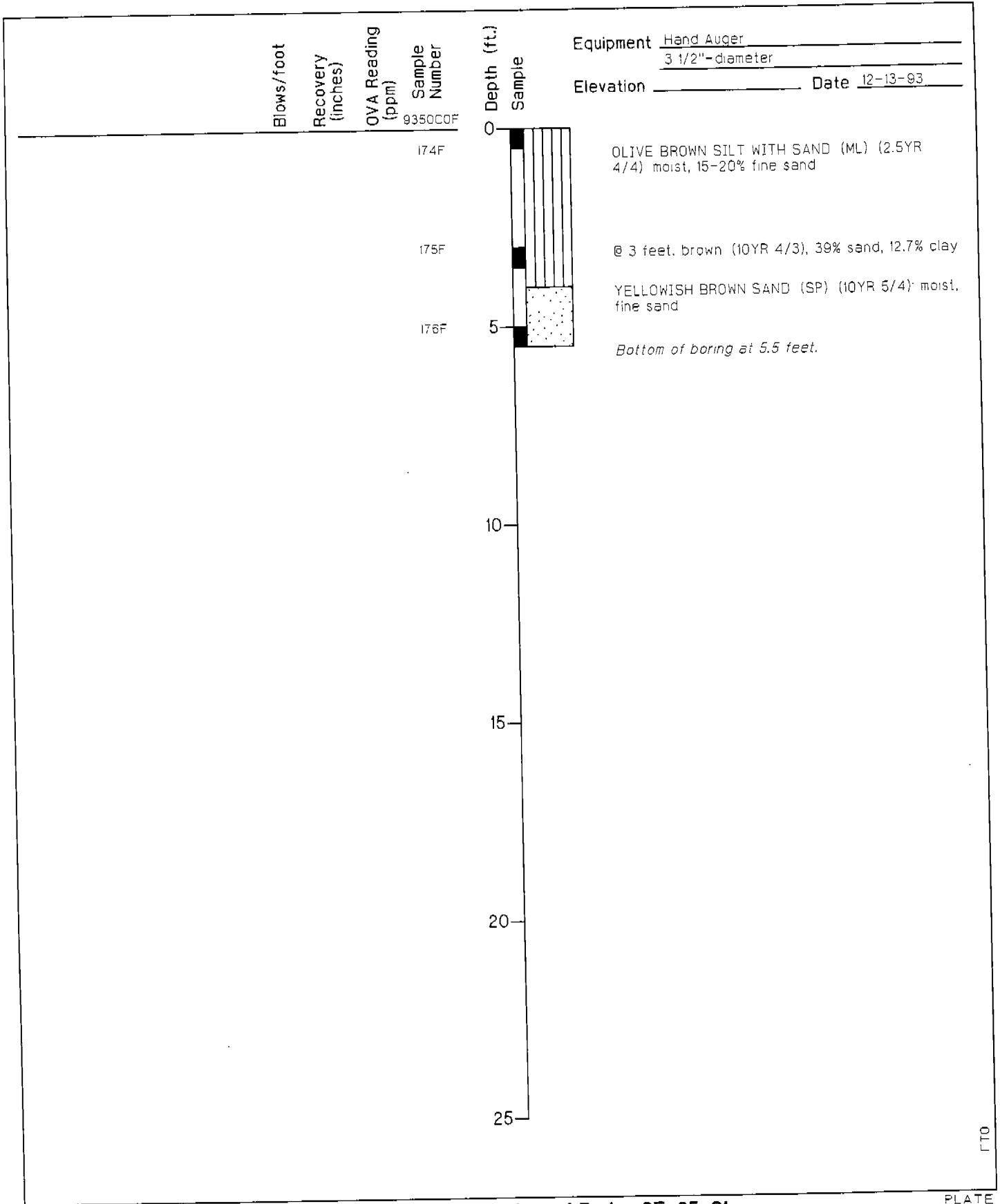

FTO

PLATE



Harding Lawson Associates
 Engineering and
 Environmental Services

Log of Boring OF-25-01
 Basewide Surface Water Investigation
 Volume II-RI, Basewide RI/FS
 Fort Ord, California

A44

DRAWN **BWH** JOB NUMBER **23366 01834**

APPROVED *[Signature]*

DATE **02/94**

REVISED DATE

Blows/foot
 Recovery (inches)
 OVA Reading (ppm)
 Sample Number

Equipment Hand Auger
3 1/2"-diameter
 Elevation _____ Date 12-13-93

9350C0F
 177F
 178F
 179F

Depth (ft.)
 Sample
 0
 5
 10
 15
 20
 25

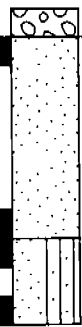

GRAVEL, varicolor, to 0.5' diameter
 YELLOWISH BROWN SAND (SP) (10YR 5/4) moist to wet, fine sand with trace of gravel
 BROWN SAND WITH SILT (SP-SM) (10YR 4/3): fine sand, 4% silt, 2% clay
 Bottom of boring at 5.5 feet.

FT0

PLATE



Harding Lawson Associates
 Engineering and
 Environmental Services

Log of Boring OF-25-02
 Basewide Surface Water Investigation
 Volume II-RI, Basewide RI/FS
 Fort Ord, California

A45

DRAWN BWH JOB NUMBER 23366 01834

APPROVED [Signature]

DATE 02/94

REVISED DATE

Site 26¹

¹ Please see Figure 5 for full citation.

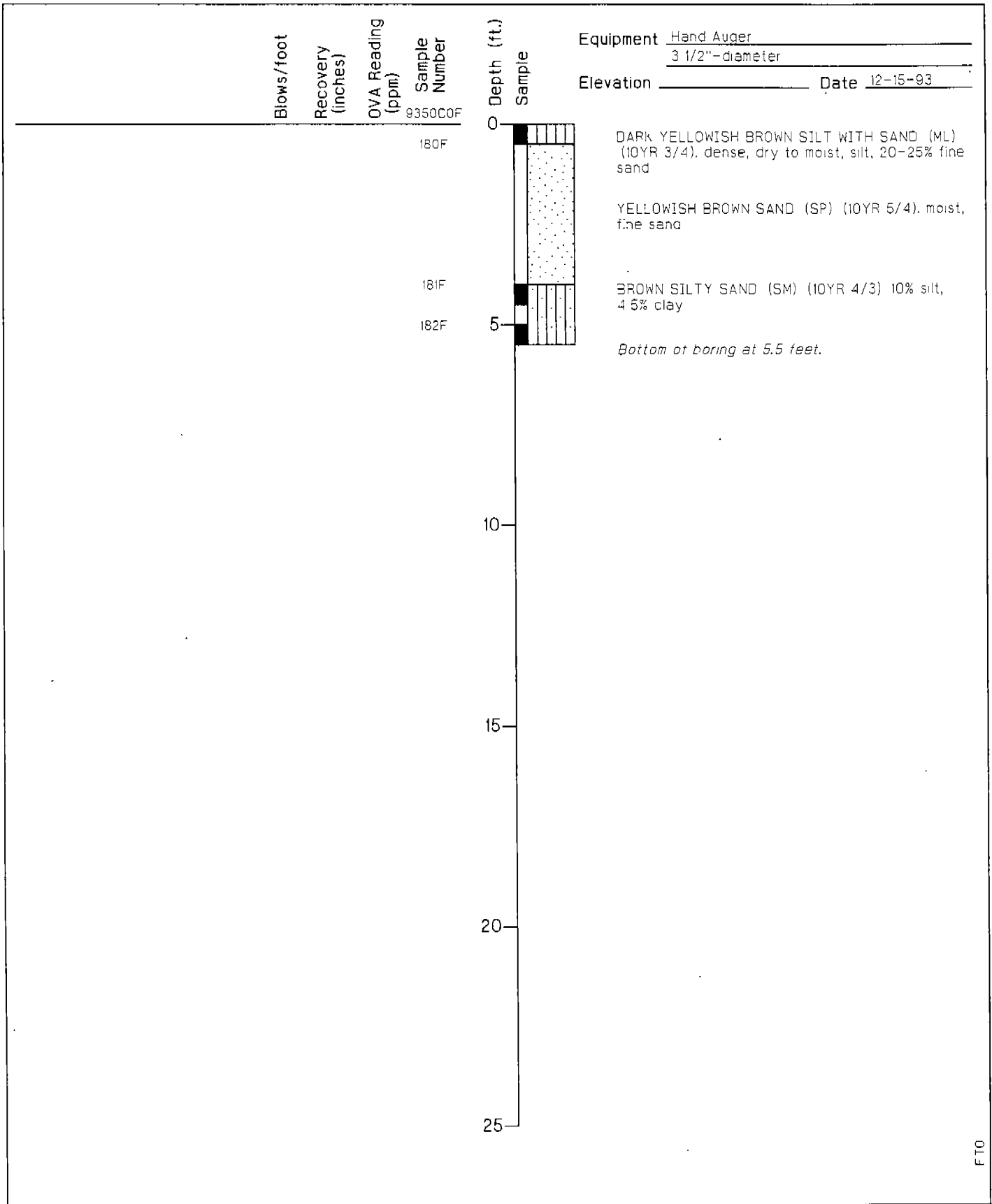

FTO

PLATE



Harding Lawson Associates
 Engineering and
 Environmental Services

Log of Boring OF-26-01
 Basewide Surface Water Investigation
 Volume II-RI, RI/FS
 Fort Ord, California

A46

DRAWN	JOB NUMBER	APPROVED	DATE	REVISED DATE
BWH	23366 01834	<i>[Signature]</i>	02/94	

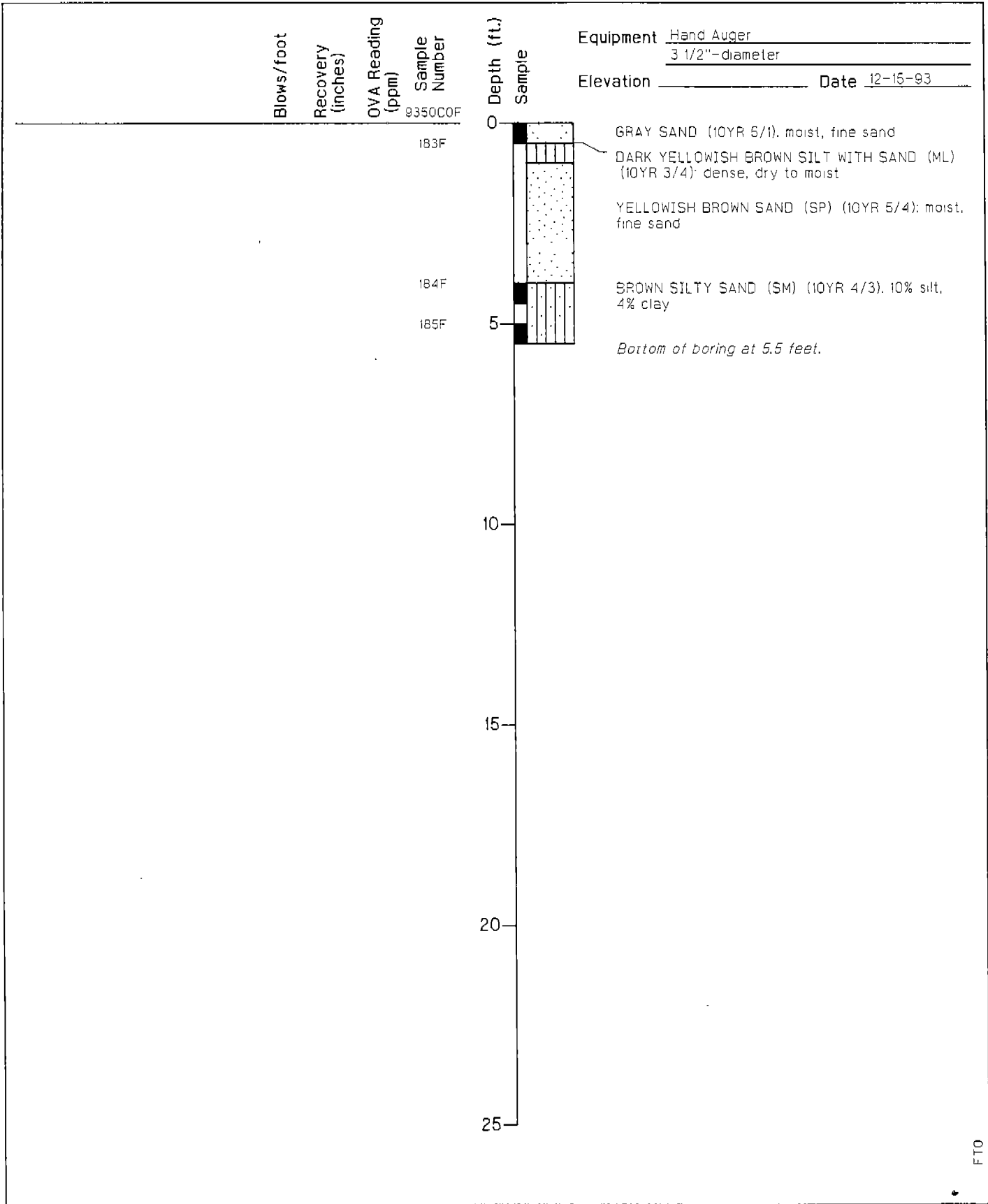

FTO



Harding Lawson Associates
 Engineering and
 Environmental Services

Log of Boring OF-26-02
 Basewide Surface Water Investigation
 Volume II-RI, Basewide RI/FS
 Fort Ord, California

PLATE

A47

DRAWN	JOB NUMBER	APPROVED	DATE	REVISED DATE
BWH	23366 01834	JDM	02/94	

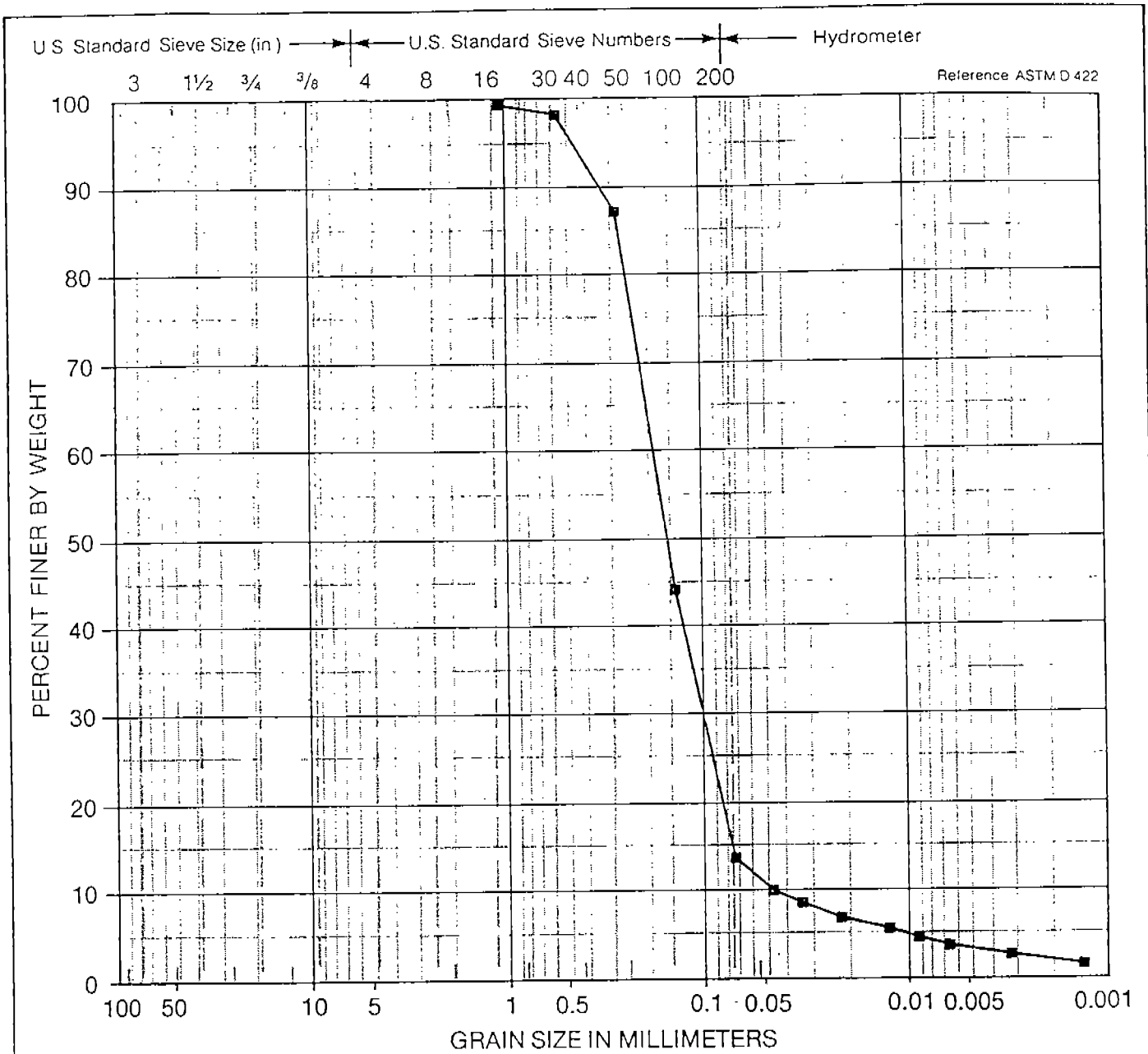

COBBLES	COARSE	FINE	COARSE	MEDIUM	FINE	SILT OR CLAY
	GRAVEL		SAND			

Symbol	Sample Source	Classification
■	OF-26-01 @ 4.0 FT	BROWN SILTY SAND (SM)



Harding Lawson Associates
Engineering and Environmental Services

Particle Size Analysis - Station OF-26-01
Basewide Surface Water Outfall Investigation
Volume II - Basewide RI/FS
Fort Ord, California

PLATE

B21

U.S. Standard Sieve Size (in.) U.S. Standard Sieve Numbers Hydrometer

3 1½ ¾ ⅜ 4 8 16 30 40 50 100 200

Reference ASTM D 422

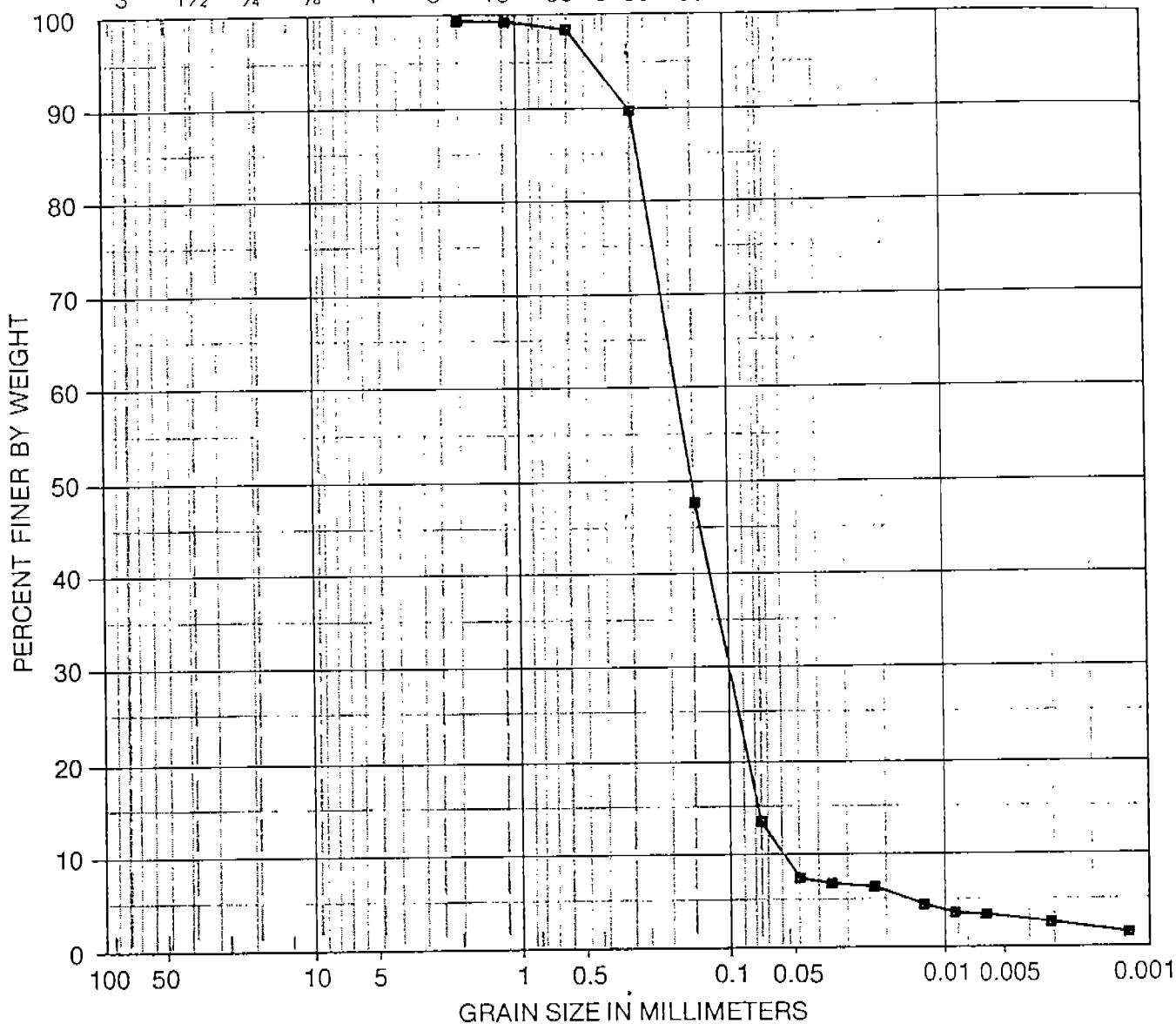

COBBLES	COARSE	FINE	COARSE	MEDIUM	FINE	SILT OR CLAY
	GRAVEL		SAND			

Symbol	Sample Source	Classification
■	OF-26-02 @ 4.0 FT	BROWN SILTY SAND (SM)



Harding Lawson Associates
Engineering and Environmental Services

Particle Size Analysis - Station OF-26-02
Basewide Surface Water Outfall Investigation
Volume II - Basewide RI/FS
Fort Ord, California

PLATE

B22

DRAWN

JOB NUMBER
23366 041712

APPROVED

DATE

12-28-1993

REVISED

DATE

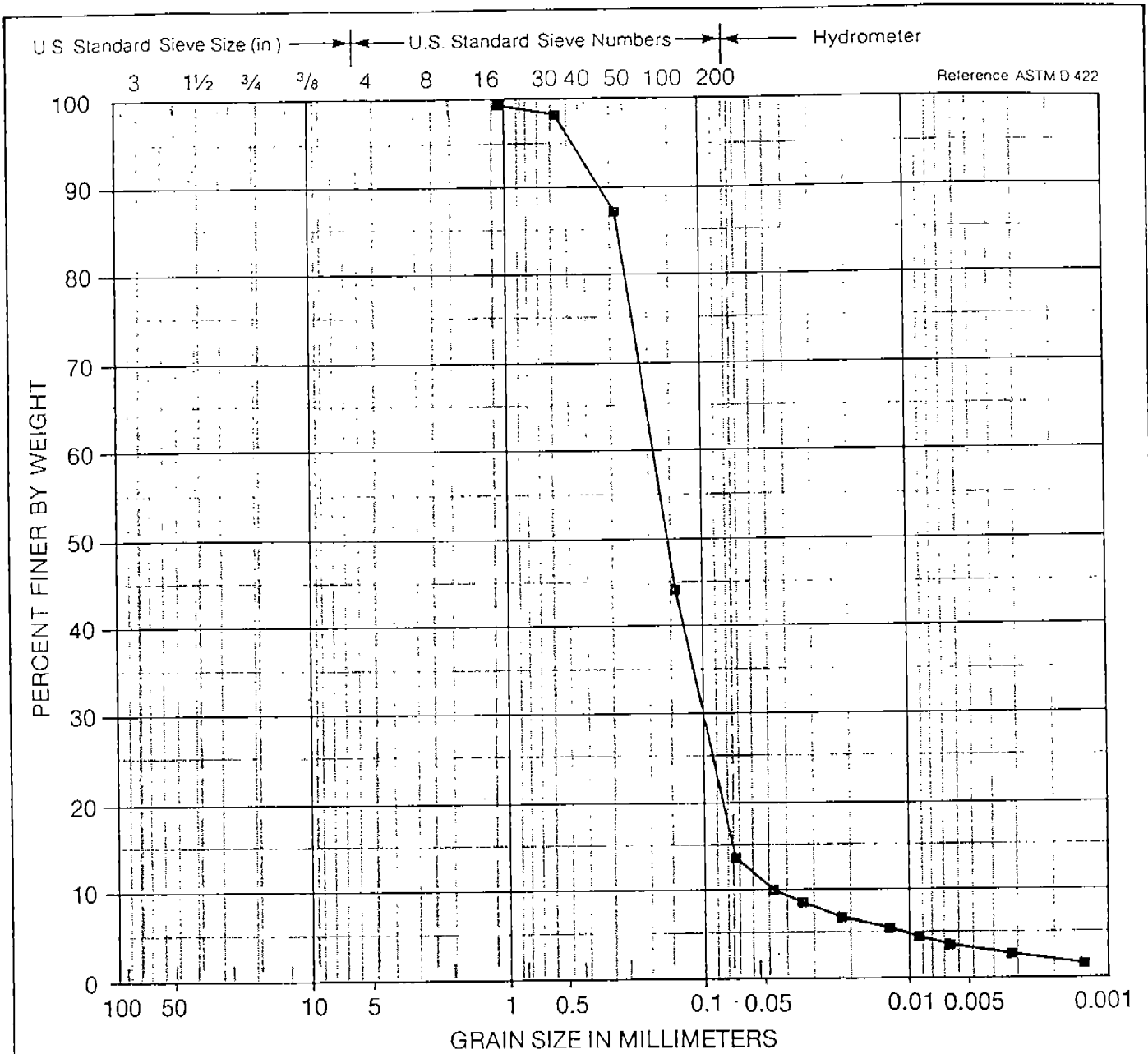

COBBLES	COARSE	FINE	COARSE	MEDIUM	FINE	SILT OR CLAY
	GRAVEL		SAND			

Symbol	Sample Source	Classification
■	OF-26-01 @ 4.0 FT	BROWN SILTY SAND (SM)



Harding Lawson Associates
Engineering and Environmental Services

Particle Size Analysis - Station OF-26-01
Basewide Surface Water Outfall Investigation
Volume II - Basewide RI/FS
Fort Ord, California

PLATE

B21

U.S. Standard Sieve Size (in.) U.S. Standard Sieve Numbers Hydrometer

3 1½ ¾ ⅜ 4 8 16 30 40 50 100 200

Reference ASTM D 422

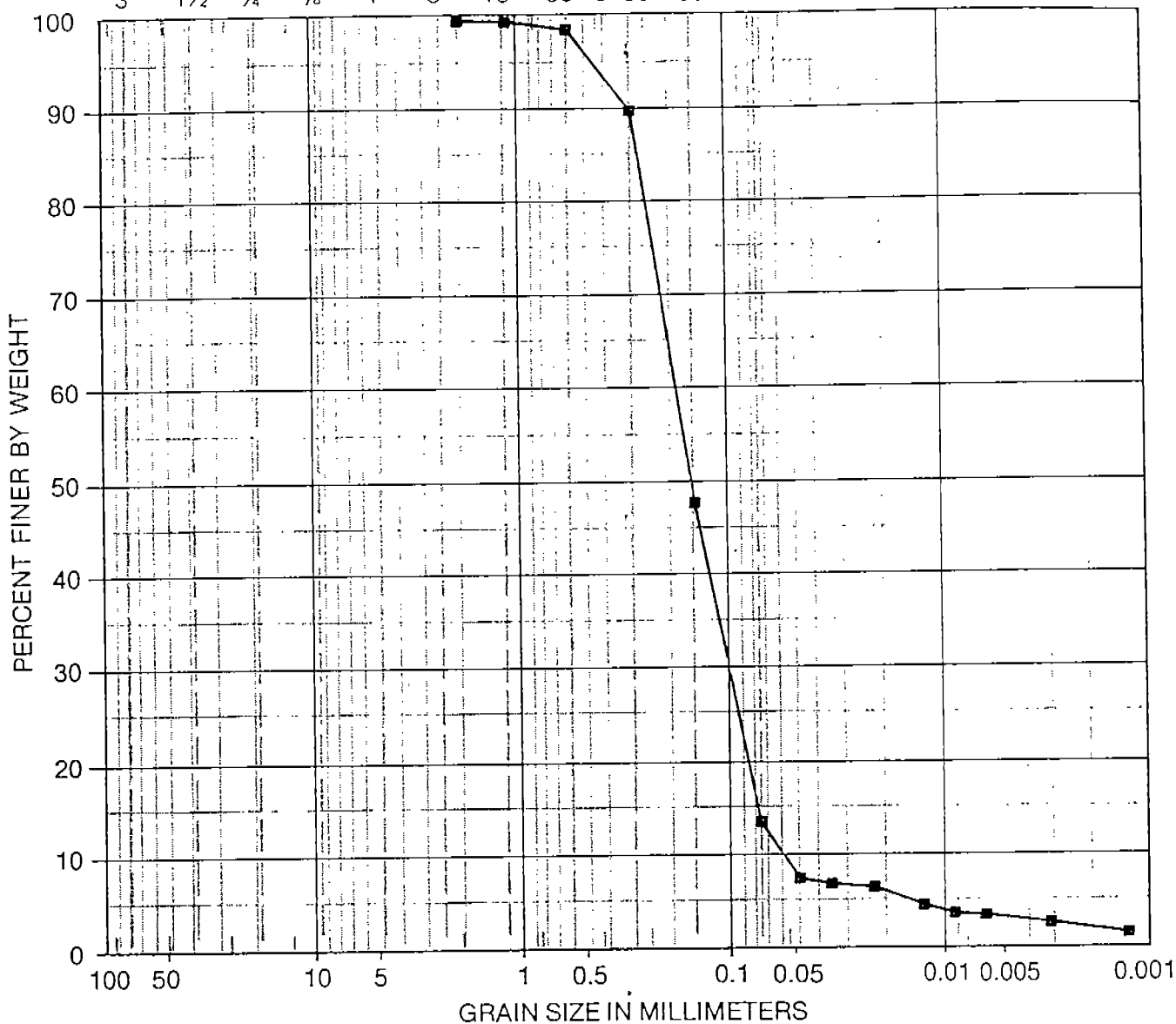

COBBLES	COARSE	FINE	COARSE	MEDIUM	FINE	SILT OR CLAY
	GRAVEL		SAND			

Symbol	Sample Source	Classification
■	OF-26-02 @ 4.0 FT	BROWN SILTY SAND (SM)



Harding Lawson Associates
Engineering and Environmental Services

Particle Size Analysis - Station OF-26-02
Basewide Surface Water Outfall Investigation
Volume II - Basewide RI/FS
Fort Ord, California

PLATE

B22

DRAWN

JOB NUMBER
23366 041712

APPROVED

DATE

12-28-1993

REVISED

DATE

Site 27¹

¹ Please see Figure 5 for full citation.

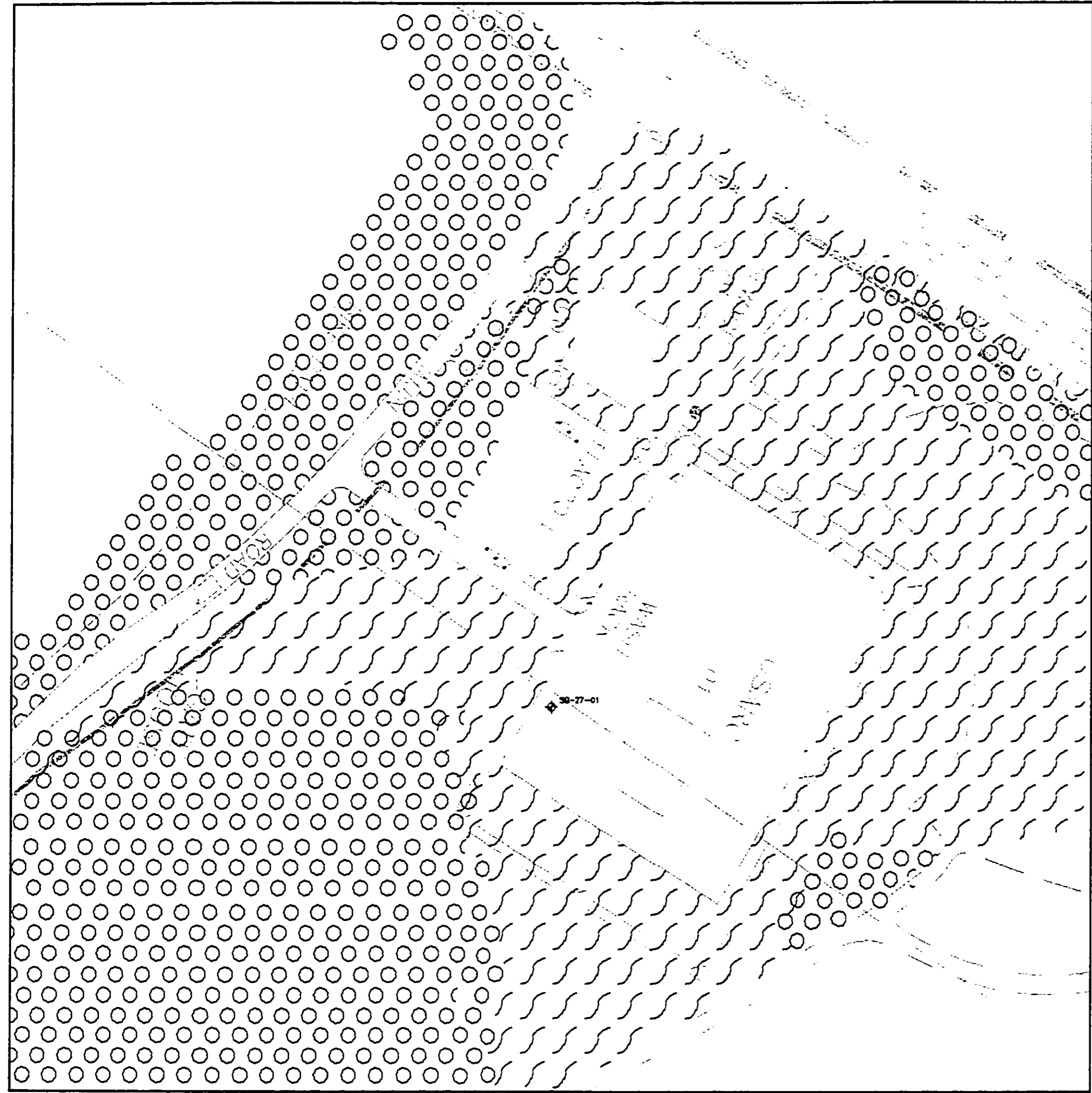

EXPLANATION

- SB-27-01 ◆ SOIL BORING LOCATION
- FULLY DEVELOPED
- ▨ UPLAND RUDERAL
- ▩ LANDSCAPED
- ⊙ COAST LIVE OAK WOODLAND

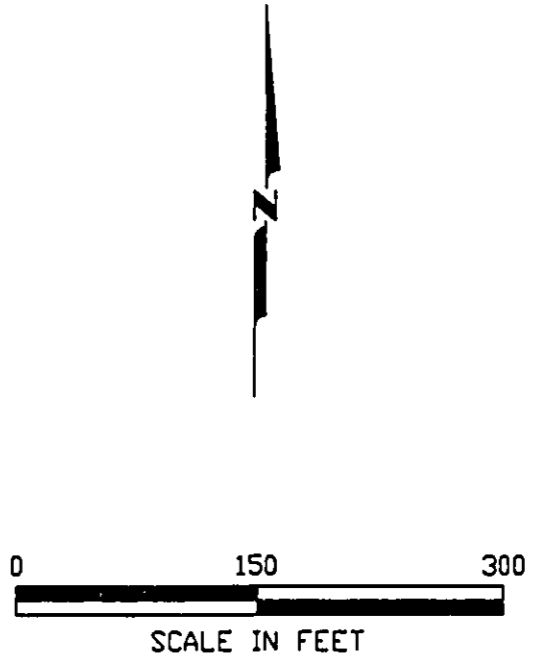

If this image is not as legible as this overlay, it's due to the poor quality of the original document

23366303_150.0
19941031.1552

NO.	DATE	REVISIONS	HLA FILE NO.	PROJECT NO.	APPROVED	APPROVAL DATE	DRAWN BY	Harding Lawson Associates Engineering and Environmental Services		Volume IV - Ecological Risk Assessment Basewide RI/FS Fort Ord, California	Plant Communities and Sampling Locations Site 27 - Army Reserve Motor Pool	PLATE: 3.17
1	6/94	DRAFT	23366303	23366 041714			MEK					
2	12/94	DRAFT FINAL	23366303	23366 041724	MEK	11/17/94	PH					

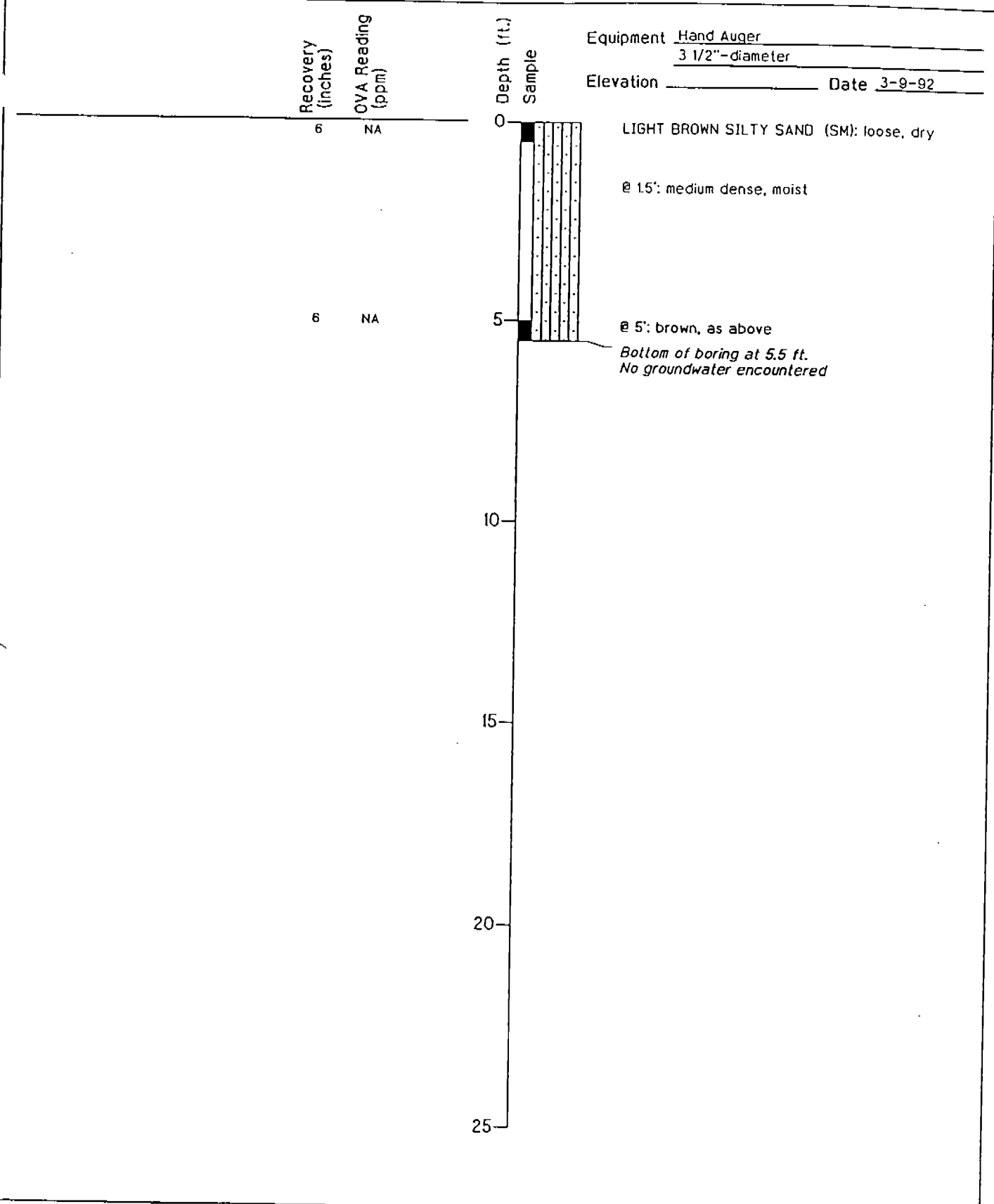

Harding Lawson Associates
 Engineering and
 Environmental Services

Log of Boring **OF-27-01**
 Basewide Surface Water Investigation
 Remedial Investigation
 Fort Ord, California

PLATE

A36

DRAWN CEG	JOB NUMBER 07579,534.02	APPROVED <i>Jbm</i>	DATE 06/92	REVISED DATE
--------------	----------------------------	------------------------	---------------	--------------

TerraTech 1997¹

¹ Please see Figure 5 for full citation.

BORING LOG

No. B-1

PROJECT FORA - NORTH SOUTH ROAD DATE 2/19/97 LOGGED BY GH

DRILL RIG Mobile B-53 HOLE DIA. 6" SAMPLER X = Mod Cal

GROUND WATER DEPTH INITIAL -- FINAL -- HOLE ELEVATION -- --

DESCRIPTION	SOIL TYPE	DEPTH	SAMPLE	BLOWS PER FOOT	POCKET PEN (tsf)	TORVANE (tsf)	LIQUID LIMIT	WATER CONTENT	PLASTIC LIMIT	DRY DENSITY (pcf)	FAILURE STRAIN (%)	UNCONFINED COMPRESSIVE STRENGTH (psf)		
SILTY SAND; medium brown, damp, loose to medium dense, fine grained sand	SM	1												
		2	S											
		3	X		10				6		101			
		4	X											
POORLY GRADED SAND; tan, damp, medium dense, fine grained sand Passing No. 200 sieve = 4%	SP	5	S		9					6		99		
		6	X											
		7												
		8												
		9	S											
		10	X		24									
		11												
		12												
		13												
		14	S											
		15	X		40									
dense BOTTOM OF BORING @ 15 FEET NO GROUND WATER ENCOUNTERED		16												
		17												
		18												
		19												
		20												

BORING LOG

No. B-2

PROJECT FORA - NORTH SOUTH ROAD DATE 2/19/97 LOGGED BY GH

DRILL RIG Mobile B-53 HOLE DIA. 6" SAMPLER X = Mod Cal

GROUND WATER DEPTH INITIAL -- FINAL -- HOLE ELEVATION --

DESCRIPTION	SOIL TYPE	DEPTH	SAMPLE	BLOWS PER FOOT	POCKET PEN (tsf)	TORVANE (tsf)	LIQUID LIMIT	WATER CONTENT	PLASTIC LIMIT	DRY DENSITY (pcf)	FAILURE STRAIN (%)	UNCONFINED COMPRESSIVE STRENGTH (psf)
SILTY SAND; medium brown, damp, loose to medium dense, fine grained sand Passing No. 200 sieve = 13%	SM	1	S	2				8		103		
		2	X									
		3	X									
		4	S									
POORLY GRADED SAND; tan, damp, medium dense, fine grained sand medium dense to dense	SP	5	X	13				8		104		
		6										
		7										
		8										
		9	S									
		10	X									
		11										
		12										
		13										
		14	S									
		15	X									
dense		16		34								
		17										
		18										
		19	S									
		20	X									
		41										

BOTTOM OF BORING @ 20 FEET
NO GROUND WATER ENCOUNTERED
PROJECT 201014.002

TERRATECH, INC.

PAGE 1 OF 1

BORING LOG

No. B-3

PROJECT FORA - NORTH SOUTH ROAD DATE 2/19/97 LOGGED BY GH
 DRILL RIG Mobile B-53 HOLE DIA. 6" SAMPLER X = Mod Cal

GROUND WATER DEPTH INITIAL -- FINAL -- HOLE ELEVATION -- --

DESCRIPTION	SOIL TYPE	DEPTH	SAMPLE	BLOWS PER FOOT	POCKET PEN (tsf)	TORVANE (tsf)	LIQUID LIMIT	WATER CONTENT	PLASTIC LIMIT	DRY DENSITY (pcf)	FAILURE STRAIN (%)	UNCOMPENED COMPRESSIVE STRENGTH (psf)
SILTY SAND; medium brown, damp, loose to medium dense, fine grained sand Passing No. 200 sieve = 13%	SM	1	S	11				10		102		
		2	X									
		3	X									
		4	S									
		5	X									
POORLY GRADED SAND; tan, damp, medium dense, fine grained sand Passing No. 200 sieve = 2%	SP	6		16				15		105		
		7										
		8										
		9	S									
		10	X									
		11	X									
		12										
		13										
		14	S									
		15	X									
BOTTOM OF BORING @ 15 FEET NO GROUND WATER ENCOUNTERED		16		23								
		17										
		18										
		19										
		20										

R-VALUE REPORT

Terratech, Inc.

ASTM D2844

(408) 297-6969

Project: Fora North South Road

Date: 02/24/97

Client: Bestor Engineering

Project #: 201014.002

Attn: Pat Ward

Lab #: J 10624 - 1

Sample #: Bulk 1

Sample Date: 02/21/97

Material Description: silty SAND; gray brown

Sampled By: C. Liang

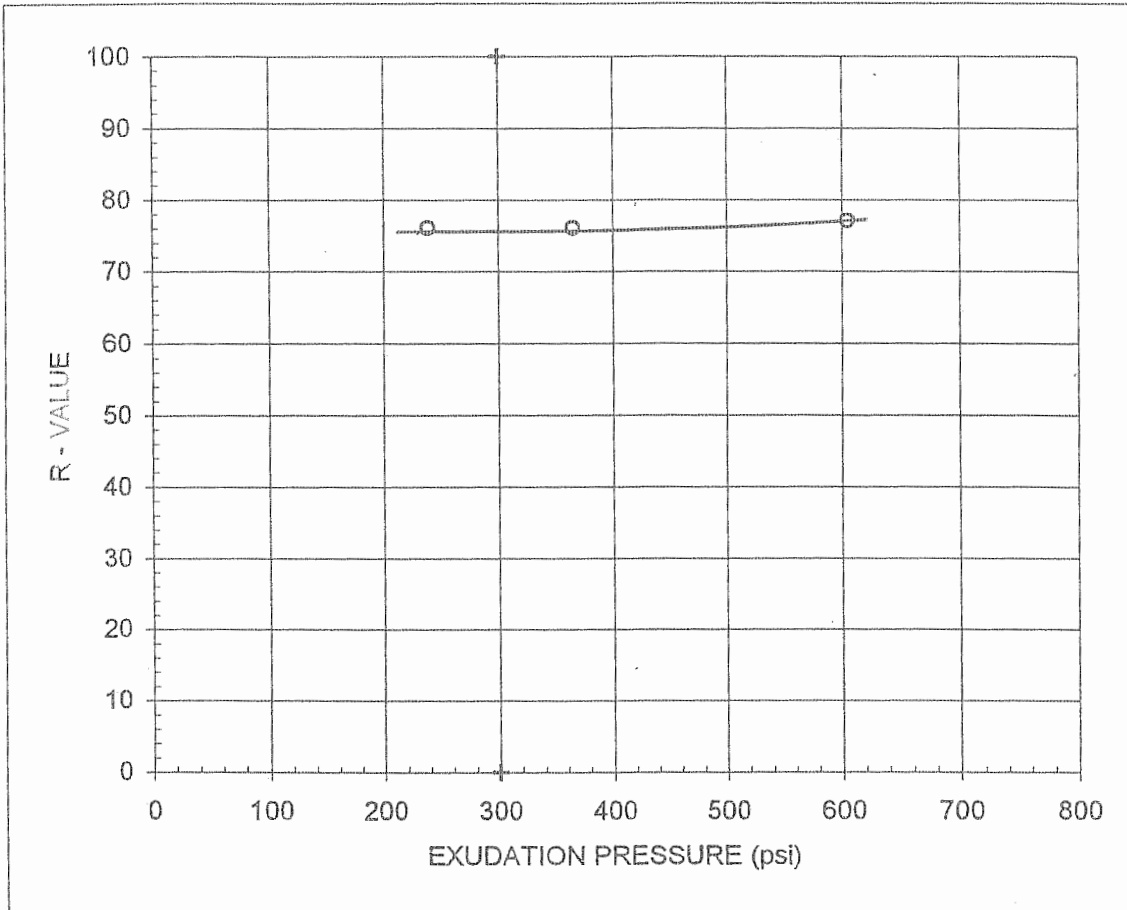

Specimen No.	A	B	C
Exudation Pressure, psi	239	366	605
Expansion Pressure, psf	17	17	22
R-Value	76	76	77
Moisture Content at Test, %	12.1	11.7	11.2
Dry Density at Test, pcf	112.4	113	114

R-Value @ 300 psi Exudation Pressure = 76 Expansion Pressure @300 psi Exudatn, psf 17

Comments:

Report By: Antonio C. Fuentse, Laboratory Manager

R341 rev.12/04/96



TERRATECH, INC.

R-VALUE REPORT

Terratech, Inc.

ASTM D2844

(408) 297-6969

Project: Fora North South Road

Date: 02/24/97

Client: Bestor Engineering

Project #: 201014.002

Attn: Pat Ward

Lab #: J 10624 - 2

Sample #: Bulk 2

Sample Date: 02/21/97

Material Description: silty SAND; brown

Sampled By: C. Liang

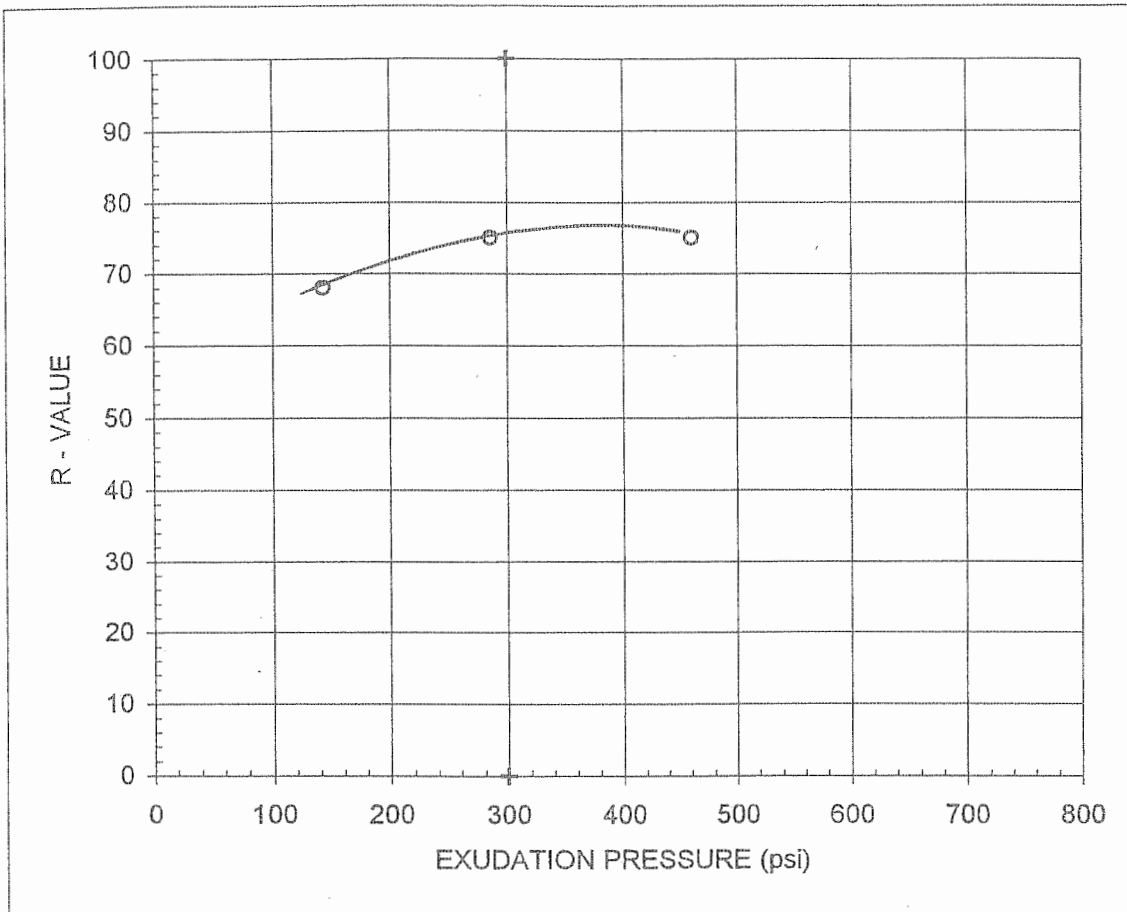

Specimen No.	A	B	C
Exudation Pressure, psi	143	286	461
Expansion Pressure, psf	0	4	4
R-Value	68	75	75
Moisture Content at Test, %	13.1	12.2	11.3
Dry Density at Test, pcf	111.5	113	114.2

R-Value @ 300 psi Exudation Pressure = 75 Expansion Pressure @300 psi Exudat'n, psf 4

Comments:

Report By: Antonio C. Fuentse, Laboratory Manager

R341 rev.12/04/96



TERRATECH, INC.

Twining Laboratories 2004¹

¹ Please see Figure 5 for full citation.

KEY TO SYMBOLS

Symbol Description

Symbol Description

Strata symbols

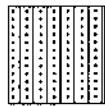

SAND, Silty (SM)



Standard penetration test

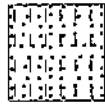

SAND, Poorly Graded with Silt (SP-SM)

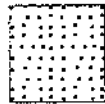

SAND, Poorly Graded (SP)

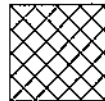

FILL

Misc. Symbols



Boring continues

Soil Samplers



California Modified split barrel ring sampler

Notes:

1. Test borings were drilled on 03/09/04 using a CME 75 equipped with 6 5/8 " O.D. Hollow Stem Auger.
2. Groundwater was encountered during drilling operations.
3. Boring locations were located by measuring wheel with reference to assumed southwest corner of the site.
4. These logs are subject to the limitations, conclusions, and recommendations in this report.
5. Results of tests conducted on samples recovered are reported on the logs. Abbreviations used are:

DD = Natural dry density	LL = Liquid limit (%)
UC = Unconfined compression (psf)	PI = Plasticity index (%)
-4 = Percent passing #4 sieve (%)	pH = Soil pH
-200 = Percent passing #200 sieve (%)	SS = Soluble sulfates (%)
SR = Soil resistivity (ohm-cm)	Cl = Soluble chlorides (%)
c = Cohesion (psf)	ϕ = Angle of internal friction (degrees)
TS = Field Torvane Shear Strength test (tsf)	
ND = None Detected	

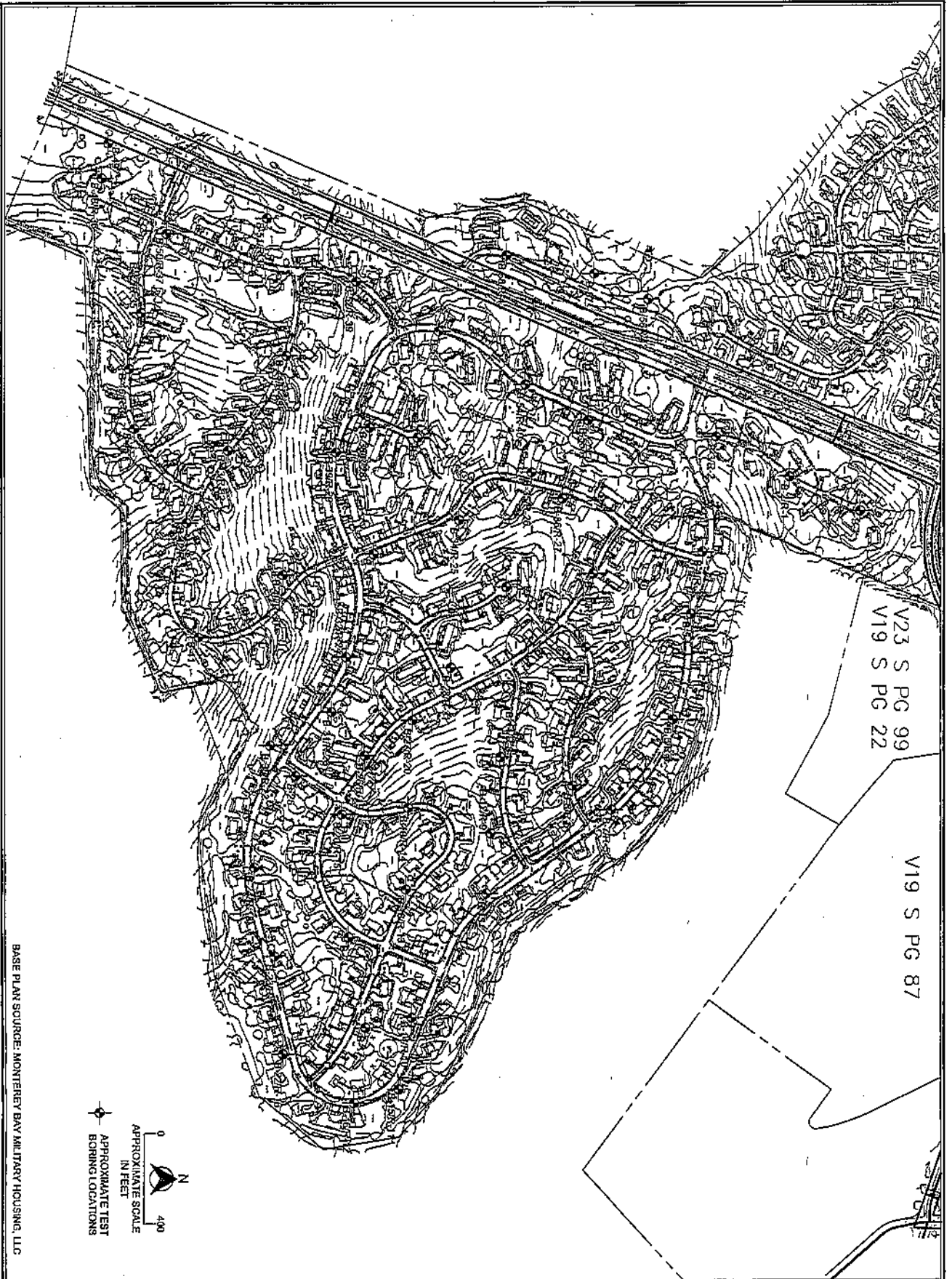

TEST BORING AND R-VALUE LOCATION MAP
 FITCH PARK MILITARY HOUSING
 MONTEREY COUNTY, CALIFORNIA

FILE NO. 82604-01	DATE DRAWN: 03/18/04
DRAWN BY: WME	APPROVED BY:
PROJECT NO. 82604.01	DRAWING NO. 2



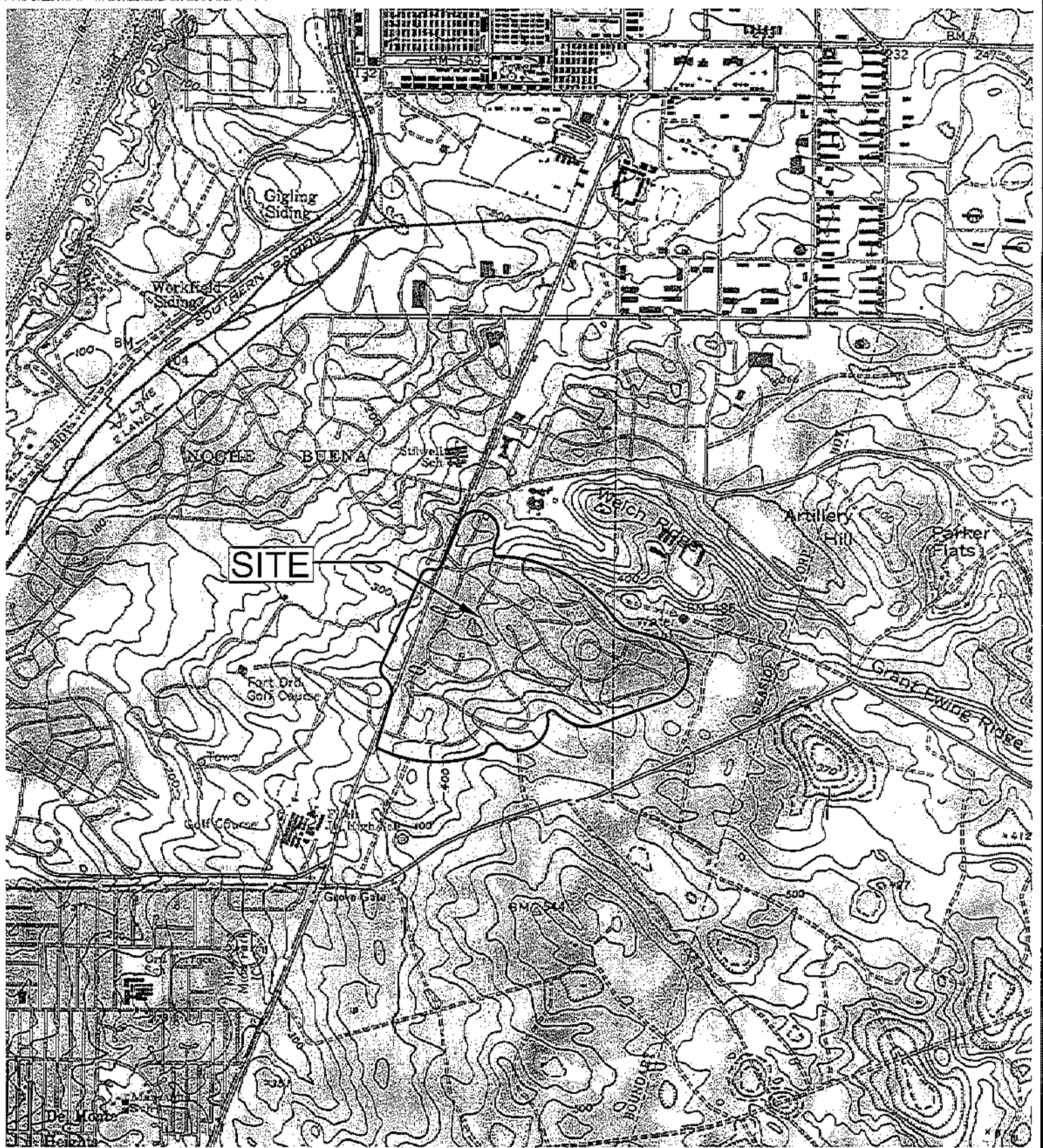

SOURCE: U.S.G.S. TOPOGRAPHIC MAP, 7 1/2 MINUTE SERIES
 SEASIDE, CALIFORNIA QUADRANGLE, PHOTOREVISED 1983



SITE LOCATION MAP
 PROPOSED FITCH PARK MILITARY HOUSING
 SEASIDE, MONTEREY COUNTY, CALIFORNIA

FILE NO.:
 82604-SLM

DATE:
 04/02/04

DRAWN BY:
 WME

APPROVED BY:

PROJECT NO.
 B82604.01

DRAWING NO.
 1



THE TWINING
 LABORATORIES, INC.
 FRESNO/MOJESTO/VISALIA/BAKERSFIELD/MONTEREY

SOIL TEST BORING SYMBOLIC LOG

BORING B-1

Project: Fitch Park, Clark Realty

Project Number: TLB82604.01

Location: Monterey, CA

Date: 03/03/04

Logged By: D. Ledgerwood

Elevation: 343 Feet

Drilled By: S. Riley

Depth to Groundwater: N/E

Drill Type: CME 75

Cased to Depth: N/A

Auger Type: 8" O.D. Hollow Stem Auger

Hammer Type: Trip

ELEVATION/ DEPTH (feet)	SOIL SYMBOLS SAMPLER SYMBOLS AND FIELD TEST DATA	USCS	Soil Description	Remarks	N-value	Moisture Content %
0		SM	AC = 3.75 inches Base = 5 inches SAND, Silty; medium dense, damp, fine to medium, light brown	DD = 99 pcf	--	4
340		SP- SM	SAND, Poorly Graded with Silt; medium dense, damp, fine, yellowish-brown			
5				Bottom of Boring at 6.5 Feet		
335						
10						
330						
15						
325						
20						
320						
25						
315						
30						

Notes:

Project: Fitch Park, Clark Realty

Project Number: TLB82604.01

Location: Monterey, CA

Date: 03/03/04

Logged By: D. Ledgerwood

Elevation: 336 Feet

Drilled By: S. Riley

Depth to Groundwater: N/E

Drill Type: CME 75

Cased to Depth: N/A

Auger Type: 8" O.D. Hollow Stem Auger

Hammer Type: Trip

ELEVATION/ DEPTH (feet)	SOIL SYMBOLS SAMPLER SYMBOLS AND FIELD TEST DATA	USCS	Soil Description	Remarks	N-value	Moisture Content %
0						
335		SM	AC = 3.75 inches Base = 5 inches	DD = 109 pcf $\phi = 30^\circ$ C = 349 psf	--	6
		SP	SAND, Silty; loose, damp, fine, dark-brown		4	6
5			SAND, Poorly Graded; loose, damp, fine, brown At 4 Feet - Medium dense, light-brown	DD = 104 pcf	--	7
330			Light reddish-brown		14	8
10						
325			Yellowish-brown		19	6
15			Bottom of Boring at 15 Feet			
320						
20						
315						
25						
310						
30						
305						

Notes:

SOIL TEST BORING SYMBOLIC LOG

BORING B-3

Project: Fitch Park, Clark Realty

Project Number: TLB82604.01

Location: Monterey, CA

Date: 03/03/04

Logged By: D. Ledgerwood

Elevation: 351 Feet

Drilled By: S. Riley

Depth to Groundwater: N/E

Drill Type: CME 75

Cased to Depth: N/A

Auger Type: 8" O.D. Hollow Stem Auger

Hammer Type: Trip

ELEVATION/ DEPTH (feet)	SOIL SYMBOLS SAMPLER SYMBOLS AND FIELD TEST DATA	USCS	Soil Description	Remarks	N-value	Moisture Content %
0						
350		SM	AC = 3.75 inches Base = 5 inches	DD = 106 pcf	--	4
		SP	SAND, Silty; loose, damp, fine to medium, dark- brown to brown		4	3
5						
345						
			Medium dense, yellowish- brown		13	4
10						
340						
15						
335						
			Dry, fine to medium		13	4
20						
330			Bottom of Boring at 20 Feet		18	2
25						
325						
30						
320						

Notes:

SOIL TEST BORING SYMBOLIC LOG

BORING B-4

Project: Fitch Park, Clark Realty

Project Number: TLB82604.01

Location: Monterey, CA

Date: 03/03/04

Logged By: D. Ledgerwood

Elevation: 378 Feet

Drilled By: S. Riley

Depth to Groundwater: N/E

Drill Type: CME 75

Cased to Depth: N/A

Auger Type: 8" O.D. Hollow Stem Auger

Hammer Type: Trip

ELEVATION/ DEPTH (feet)	SOIL SYMBOLS SAMPLER SYMBOLS AND FIELD TEST DATA	USCS	Soil Description	Remarks	N-value	Moisture Content %	
0		SM	Grass with fine roots SAND, Silty; medium dense, damp to moist, fine, light-brown At 3 Feet - Light reddish-brown	DD = 99 pcf -200 = 12%	12	8	
375					--	9	
5						11	8
370			SP	SAND, Poorly Graded; medium dense, damp, fine to medium, light-brown		18	4
10							
365							
15					23	4	
360			Bottom of Boring at 16.5 Feet				
20							
355							
25							
350							
30							

Notes:

SOIL TEST BORING SYMBOLIC LOG

BORING B-5

Project: Fitch Park, Clark Realty

Location: Monterey, CA

Logged By: D. Ledgerwood

Drilled By: S. Riley

Drill Type: CME 75

Auger Type: 8" O.D. Hollow Stem Auger

Project Number: TLB82604.01

Date: 03/03/04

Elevation: 383 Feet

Depth to Groundwater: N/E

Cased to Depth: N/A

Hammer Type: Trip

ELEVATION/ DEPTH (feet)	SOIL SYMBOLS SAMPLER SYMBOLS AND FIELD TEST DATA	USCS	Soil Description	Remarks	N-value	Moisture Content %
0		SM	AC = 4 inches Base = 5 inches SAND, Silty; medium dense, damp, fine, brown	DD = 109 pcf	--	4
380					16	5
5				Moist, fine to medium, trace clay, reddish-brown	DD = 102 pcf	--
375		SP- SM	SAND, Poorly Graded with Silt; medium dense, damp, fine to medium, yellowish- brown		16	5
10			Light-brown			
370					20	5
15						
365			Bottom of Boring at 16.5 Feet			
20						
360						
25						
355						
30						

Notes:

Project: Fitch Park, Clark Realty
 Location: Monterey, CA
 Logged By: D. Ledgerwood
 Drilled By: S. Riley
 Drill Type: CME 75
 Auger Type: 8" O.D. Hollow Stem Auger

Project Number: TLB82604.01
 Date: 03/03/04
 Elevation: 422 Feet
 Depth to Groundwater: N/E
 Cased to Depth: N/A
 Hammer Type: Trip

ELEVATION/ DEPTH (feet)	SOIL SYMBOLS SAMPLER SYMBOLS AND FIELD TEST DATA	USCS	Soil Description	Remarks	N-value	Moisture Content %
0			AC = 4 inches Base - 5 inches	DD = 104 pcf	--	3
420	5/6 6/6 7/6	SP	SAND, Poorly Graded; medium dense, damp, fine to medium, yellowish- brown		13	5
5						
415						
10	4/6 7/6 10/6	SM	SAND, Silty; medium dense, moist, fine, yellowish- brown		17	9
410						
15	19/6 20/6 16/6		Dense, increase in silt, grayish-brown		36	7
405						
20	4/6 11/6 13/6	SP	SAND, Poorly Graded; medium dense, damp, fine to medium with interbedded silty sand with trace clay, light-brown		24	5
400			Bottom of Boring at 20 Feet			
25						
395						
30						
390						

Notes:

Project: Fitch Park, Clark Realty

Project Number: TLB82604.01

Location: Monterey, CA

Date: 03/04/04

Logged By: D. Ledgerwood

Elevation: 434 Feet

Drilled By: S. Riley

Depth to Groundwater: N/E

Drill Type: CME 75

Cased to Depth: N/A

Auger Type: 8" O.D. Hollow Stem Auger

Hammer Type: Trip

ELEVATION/ DEPTH (feet)	SOIL SYMBOLS SAMPLER SYMBOLS AND FIELD TEST DATA	USCS	Soil Description	Remarks	N-value	Moisture Content %
0						
430	6/6 16/6 27/6	SM	AC = 3.5 inches Base = 6 inches SAND, Silty; damp, fine, brown	DD = 113 pcf	43	6
5	14/6 18/6 19/6		Dry, increase in silt, fine		37	2
425	6/6 10/6 11/6		Medium dense, decrease in percent silt, slightly cemented		21	3
420	4/6 8/6 15/6	SP- SM	SAND, Poorly Graded with Silt; medium dense, dry, fine, yellowish-brown		23	2
415	4/6 11/6 18/6	SP	SAND, Poorly Graded; medium dense, damp, fine, yellowish-brown		29	3
410	6/6 17/6 17/6				34	3
405	7/6 11/6 19/6	SM	SAND, Silty; medium dense, moist, fine to medium, trace fine subrounded gravel		30	10

Notes:

SOIL TEST BORING SYMBOLIC LOG

BORING B-7

Project: Fitch Park, Clark Realty
 Location: Monterey, CA
 Logged By: D. Ledgerwood
 Drilled By: S. Riley
 Drill Type: CME 75
 Auger Type: 8" O.D. Hollow Stem Auger

Project Number: TLB82604.01
 Date: 03/04/04
 Elevation: 434 Feet
 Depth to Groundwater: N/E
 Cased to Depth: N/A
 Hammer Type: Trip

ELEVATION/ DEPTH (feet)	SOIL SYMBOLS SAMPLER SYMBOLS AND FIELD TEST DATA	USCS	Soil Description	Remarks	N-value	Moisture Content %
400 35		SP- SM	SAND, Poorly Graded with Silt; medium dense, damp, fine to medium, light-brown		28	5
395 40		SP	SAND, Poorly Graded; dense, damp, fine to medium, yellowish-brown		43	4
390 45						
385 50			Moist, fine, yellowish-brown		39	7
380 55			Bottom of Boring at 51.5 Feet			
375 60						
370 65						

Notes:

SOIL TEST BORING SYMBOLIC LOG

BORING B-8

Project: Fitch Park, Clark Realty
 Location: Monterey, CA
 Logged By: D. Ledgerwood
 Drilled By: S. Riley
 Drill Type: CME 75
 Auger Type: 8" O.D. Hollow Stem Auger

Project Number: TLB82604.01
 Date: 03/04/04
 Elevation: 410 Feet
 Depth to Groundwater: N/E
 Cased to Depth: N/A
 Hammer Type: Trip

ELEVATION/ DEPTH (feet)	SOIL SYMBOLS SAMPLER SYMBOLS AND FIELD TEST DATA	USCS	Soil Description	Remarks	N-value	Moisture Content %
410 - 0			AC = 4 inches Base = 5 inches	DD = 113 pcf	--	6
	13/6 16/6 13/6	SM	SAND, Silty; medium dense, damp, fine to medium, trace fine subrounded gravel, brown		29	5
405 - 5		SP- SM	At 1.8 Feet - No gravel, trace silt	DD = 103 pcf	--	7
	5/6 6/6 9/6	SM	SAND, Poorly Graded with silt; medium dense, moist, fine to medium, light- brown		15	9
400 - 10			SAND, Silty; medium dense, moist, fine to medium, yellowish-brown to brown			
	8/6 11/6 11/6	SP- SM	SAND, Poorly Graded with Silt; medium dense, damp, fine to medium, light- brown		22	7
395 - 15						
	7/6 11/6 12/6	SP	SAND, Poorly Graded; medium dense, damp, fine, yellowish-brown		23	5
390 - 20			Bottom of Boring at 20 Feet			
385 - 25						
380 - 30						

Notes:

Project: Fitch Park, Clark Realty

Project Number: TLB82604.01

Location: Monterey, CA

Date: 03/04/04

Logged By: D. Ledgerwood

Elevation: 368 Feet

Drilled By: S. Riley

Depth to Groundwater: N/E

Drill Type: CME 75

Cased to Depth: N/A

Auger Type: 8" O.D. Hollow Stem Auger

Hammer Type: Trip

ELEVATION/ DEPTH (feet)	SOIL SYMBOLS SAMPLER SYMBOLS AND FIELD TEST DATA	USCS	Soil Description	Remarks	N-value	Moisture Content %	
0		SM	AC = 3.5 inches Base = 2.5 inches SAND, Silty; medium dense, moist, fine to medium, yellowish-brown At 3 Feet = Dark yellowish-brown	DD = 106 pcf	--	8	
365					15	10	
5							
360			SP	SAND, Poorly Graded; medium dense, damp, fine, yellowish-brown		11	5
10							
355					24	3	
15							
350			Fine to medium		27	4	
20			Bottom of boring at 20 Feet				
345							
25							
340							
30							

Notes:

Project: Fitch Park, Clark Realty
 Location: Monterey, CA
 Logged By: D. Ledgerwood
 Drilled By: S. Riley
 Drill Type: CME 75
 Auger Type: 8" O.D. Hollow Stem Auger

Project Number: TLB82604.01
 Date: 03/04/04
 Elevation: 356 Feet
 Depth to Groundwater: N/E
 Cased to Depth: N/A
 Hammer Type: Trip

ELEVATION/ DEPTH (feet)	SOIL SYMBOLS SAMPLER SYMBOLS AND FIELD TEST DATA	USCS	Soil Description	Remarks	N-value	Moisture Content %
0						
355		SM	AC = 3 inches Base = 3 inches SAND, Silty; medium dense, damp, fine, brown At 3 Feet - Loose, moist At 5 Feet - Moist, trace clay, reddish-brown	DD = 103 pcf	18	6
5					--	6
350					10	11
10						
345		SP	SAND, Poorly Graded; medium dense, damp, fine to medium, light yellowish- brown		12	5
15						
340					18	5
20						
335						
25						
330						
30						
325						
			Bottom of Boring at 16.5 Feet			

Notes:

Project: Fitch Park, Clark Realty

Project Number: TLB82604.01

Location: Monterey, CA

Date: 03/04/04

Logged By: D. Ledgerwood

Elevation: 394 Feet

Drilled By: S. Riley

Depth to Groundwater: N/E

Drill Type: CME 75

Cased to Depth: N/A

Auger Type: 8" O.D. Hollow Stem Auger

Hammer Type: Trip

ELEVATION/ DEPTH (feet)	SOIL SYMBOLS SAMPLER SYMBOLS AND FIELD TEST DATA	USCS	Soil Description	Remarks	N-value	Moisture Content %
0		SM	Grass with top soils, fine roots			
390		SP	SAND, Silty; loose, moist, fine to medium, brown	DD = 110 pcf	--	10
5			SAND, Poorly Graded; loose, moist, fine to medium, yellowish-brown	DD = 101 pcf	9	9
10					10	11
385						
15			Medium dense, damp, slight decrease in grain size		24	4
380						
20			Bottom of Boring at 20 Feet		26	4
375						
370						
25						
365						
30						

Notes:

Project: Fitch Park, Clark Realty

Project Number: TLB82604.01

Location: Monterey, CA

Date: 03/08/04

Logged By: D. Ledgerwood

Elevation: 415 Feet

Drilled By: T. Conley

Depth to Groundwater: N/E

Drill Type: CME 75

Cased to Depth: N/A

Auger Type: 6 5/8 " O.D. Hollow Stem Auger

Hammer Type: Trip

ELEVATION/ DEPTH (feet)	SOIL SYMBOLS SAMPLER SYMBOLS AND FIELD TEST DATA	USCS	Soil Description	Remarks	N-value	Moisture Content %
415 0		SM	SAND, Silty; loose, moist, fine, dark-brown Brown to light brown	DD = 110 pcf	--	11
					7	10
410 5		SP	SAND, Poorly Graded; medium dense, dry to damp, fine, yellowish- brown		15	3
405 10						
400 15						
395 20			Bottom of Boring at 20 Feet		26	3
390 25						
385 30						

Notes:

Project: Fitch Park, Clark Realty

Project Number: TLB82604.01

Location: Monterey, CA

Date: 03/04/04

Logged By: D. Ledgerwood

Elevation: 423 Feet

Drilled By: S. Riley













Depth to Groundwater: N/E

Drill Type: CME 75

Cased to Depth: N/A

Auger Type: 8" O.D. Hollow Stem Auger

Hammer Type: Trip

ELEVATION/ DEPTH (feet)	SOIL SYMBOLS SAMPLER SYMBOLS AND FIELD TEST DATA	USCS	Soil Description	Remarks	N-value	Moisture Content %
0		SM	SAND, Silty; very loose, moist, fine, dark-brown		3	7
420				DD = 94 pcf	--	9
5			Brown		4	8
415						
10		SP	SAND, Poorly Graded, loose, damp, fine, yellowish- brown		9	3
410			Medium dense			
15					15	4
405						
20			Increase in percent fine sand		24	4
400						
25					18	4
395						
30					21	4
			Bottom of Boring at 31.5 Feet			

Notes:

Project: Fitch Park, Clark Realty

Project Number: TLB82604.01

Location: Monterey, CA

Date: 03/04/04

Logged By: D. Ledgerwood

Elevation: 412 Feet

Drilled By: S. Riley

Depth to Groundwater: N/E

Drill Type: CME 75

Cased to Depth: N/A

Auger Type: 8" O.D. Hollow Stem Auger

Hammer Type: Trip

ELEVATION/ DEPTH (feet)	SOIL SYMBOLS SAMPLER SYMBOLS AND FIELD TEST DATA	USCS	Soil Description	Remarks	N-value	Moisture Content %
0		SM	SAND, Silty; loose, moist, fine, dark-brown	DD = 106 pcf	--	10
410			Brown		8	8
5						
405		SP	SAND, Poorly Graded; loose, moist, fine, yellowish- brown Damp	DD = 97 pcf	--	7
10			Medium dense		10	5
400						
15			Bottom of Boring at 16.5 Feet		15	5
395						
20						
390						
25						
385						
30						
380						

Notes:

Project: Fitch Park, Clark Realty

Project Number: TLB82604.01

Location: Monterey, CA

Date: 03/04/04

Logged By: D. Ledgerwood

Elevation: 431 Feet

Drilled By: S. Riley

Depth to Groundwater: N/E

Drill Type: CME 75

Cased to Depth: N/A

Auger Type: 8" O.D. Hollow Stem Auger

Hammer Type: Trip

ELEVATION/ DEPTH (feet)	SOIL SYMBOLS SAMPLER SYMBOLS AND FIELD TEST DATA	USCS	Soil Description	Remarks	N-value	Moisture Content %
0						
430	1/6 2/6 3/6	SM SP- SM	SAND, Silty; loose, moist, fine to medium dark- brown with roots		5	14
			SAND, Poorly Graded with Silt; loose, moist, fine, yellowish-brown	DD = 104 pcf	--	9
425	5/6 7/6 6/6		At 4 Feet - Medium dense, dark yellowish-brown		13	7
420	3/6 5/6 7/6	SP	SAND, Poorly Graded; medium dense, damp, fine, yellowish-brown		12	5
415	5/6 12/6 12/6		Moist		24	7
410	5/6 12/6 16/6		Damp, fine to medium		28	3
405	5/6 15/6 17/6		Dense		32	4
400	2/6 10/6 15/6		Medium dense, trace silt		25	4

Notes:

Project: Fitch Park, Clark Realty

Project Number: TLB82604.01

Location: Monterey, CA

Date: 03/04/04

Logged By: D. Ledgerwood

Elevation: 431 Feet

Drilled By: S. Riley

Depth to Groundwater: N/E

Drill Type: CME 75

Cased to Depth: N/A

Auger Type: 8" O.D. Hollow Stem Auger

Hammer Type: Trip

ELEVATION/ DEPTH (feet)	SOIL SYMBOLS SAMPLER SYMBOLS AND FIELD TEST DATA	USCS	Soil Description	Remarks	N-value	Moisture Content %
395					27	3
390		SM	SAND, Silty; dense, moist, fine, grayish-brown with reddish-brown interbeds		42	10
385						
380			Fine to medium, reddish-brown		47	9
375			Bottom of Boring at 51.5 Feet			
370						
65						

Notes:

Project: Fitch Park, Clark Realty

Project Number: TLB82604.01

Location: Monterey, CA

Date: 03/04/04

Logged By: D. Ledgerwood

Elevation: 430 Feet

Drilled By: S. Riley

Depth to Groundwater: N/E

Drill Type: CME 75

Cased to Depth: N/A

Auger Type: 8" O.D. Hollow Stem Auger

Hammer Type: Trip

ELEVATION/ DEPTH (feet)	SOIL SYMBOLS SAMPLER SYMBOLS AND FIELD TEST DATA	USCS	Soil Description	Remarks	N-value	Moisture Content %	
430 0		SM	AC = 3.5 inches Base = 5 inches SAND, Silty; medium dense, moist, fine, brown		25	7	
425 5			Yellowish-brown	DD = 107 pcf	--	7	
420 10						11	9
415 15			SP	SAND, Poorly Graded; dense, damp, fine to medium, reddish-brown		30	5
410 20		SP- SM	SAND, Poorly Graded with Silt; dense, moist, fine to medium, reddish-brown		36	7	
			Bottom of Boring at 20 Feet				
405 25							
400 30							

Notes:

Project: Fitch Park, Clark Realty

Project Number: TLB82604.01

Location: Monterey, CA

Date: 03/04/04

Logged By: D. Ledgerwood

Elevation: 422 Feet

Drilled By: S. Riley

Depth to Groundwater: N/E

Drill Type: CME 75

Cased to Depth: N/A

Auger Type: 8" O.D. Hollow Stem Auger

Hammer Type: Trip

ELEVATION/ DEPTH (feet)	SOIL SYMBOLS SAMPLER SYMBOLS AND FIELD TEST DATA	USCS	Soil Description	Remarks	N-value	Moisture Content %
0		SM	SAND, Silty; loose, moist, fine, dark-brown to black	DD = 99 pcf φ = 350° C = 403 psf	-- 8	12 10
420		SP- SM	SAND, Poorly Graded with Silt; loose, moist, fine, yellowish-brown	DD = 108 pcf	-- 10	10 7
415		SP	SAND, Poorly Graded; medium dense, damp, fine, yellowish-brown		19	5
410			Bottom of Boring at 15 Feet			
15						
405						
20						
400						
25						
395						
30						
390						

Notes:

Project: Fitch Park, Clark Realty

Project Number: TLB82604.01

Location: Monterey, CA

Date: 03/05/04

Logged By: D. Ledgerwood

Elevation: 418 Feet

Drilled By: S. Riley

Depth to Groundwater: N/E

Drill Type: CME 75

Cased to Depth: N/A

Auger Type: 8" O.D. Hollow Stem Auger

Hammer Type: Trip

ELEVATION/ DEPTH (feet)	SOIL SYMBOLS SAMPLER SYMBOLS AND FIELD TEST DATA	USCS	Soil Description	Remarks	N-value	Moisture Content %
0		SM	SAND, Silty; loose, moist, fine, dark-brown, with roots Brown Medium dense, fine to medium, light reddish- brown Yellowish-brown	DD = 106 pcf	--	9
415					9	13
410					11	8
405					18	6
400		SP- SM	SAND, Poorly Graded with Silt; medium dense, damp, fine to medium, yellowish- brown		15	5
400			Bottom of Boring at 16.5 Feet			
395						
390						
385						
380						
375						
370						
365						
360						
355						
350						
345						
340						
335						
330						
325						
320						
315						
310						
305						
300						

Notes:

Project: Fitch Park, Clark Realty

Project Number: TLB82604.01

Location: Monterey, CA

Date: 03/05/04

Logged By: D. Ledgerwood

Elevation: 412 Feet

Drilled By: S. Riley

Depth to Groundwater: N/E

Drill Type: CME 75

Cased to Depth: N/A

Auger Type: 8" O.D. Hollow Stem Auger

Hammer Type: Trip

ELEVATION/ DEPTH (feet)	SOIL SYMBOLS SAMPLER SYMBOLS AND FIELD TEST DATA	USCS	Soil Description	Remarks	N-value	Moisture Content %
0		SP- SM	AC = 3 inches Base = 4 inches	DD = 102 pcf -200 = 12%	--	2
410		SM	SAND, Poorly Graded with Silt; medium dense, dry, fine, light-brown			
5			SAND, Silty; medium dense, damp, fine, slightly cemented, yellowish-brown		27	5
405			SP	SAND, Poorly Graded; medium dense, damp, fine, yellowish-brown		20
10						
400						
15						
395			Bottom of Boring at 16.5 Feet			
20						
390						
25						
385						
30						
380						

Notes:

Project: Fitch Park, Clark Realty

Project Number: TLB82604.01

Location: Monterey, CA

Date: 03/05/04

Logged By: D. Ledgerwood

Elevation: 396 Feet

Drilled By: S. Riley

Depth to Groundwater: N/E

Drill Type: CME 75

Cased to Depth: N/A

Auger Type: 8" O.D. Hollow Stem Auger

Hammer Type: Trip

ELEVATION/ DEPTH (feet)	SOIL SYMBOLS SAMPLER SYMBOLS AND FIELD TEST DATA	USCS	Soil Description	Remarks	N-value	Moisture Content %
0		SM	SAND, Silty; very loose, moist, fine, with roots, dark-brown with interbeds light-brown	DD = 97 pcf	--	10
395			Loose	DD = 100 pcf	3	9
5		SP-SM	SAND, Poorly Graded with Silt; loose, moist, fine yellowish-brown		7	7
390			Medium dense, moist		21	9
10			Dense, damp		32	4
385			Bottom of Boring at 20 Feet			
15						
380						
20						
375						
25						
370						
30						
365						

Notes:

Project: Fitch Park, Clark Realty

Project Number: TLB82604.01

Location: Monterey, CA

Date: 03/05/04

Logged By: D. Ledgerwood

Elevation: 410 Feet

Drilled By: S. Riley





Depth to Groundwater: N/E

Drill Type: CME 75

Cased to Depth: N/A

Auger Type: 8" O.D. Hollow Stem Auger

Hammer Type: Trip

ELEVATION/ DEPTH (feet)	SOIL SYMBOLS SAMPLER SYMBOLS AND FIELD TEST DATA	USCS	Soil Description	Remarks	N-value	Moisture Content %
410 - 0	 3/6 4/6 4/6	SM	SAND, Silty; loose, moist, fine, with light-brown interbeds		8	8
			Medium dense	DD = 98 pcf	--	7
405 - 5	 4/6 5/6 7/6	SP- SM	SAND, Poorly Graded with Silt; medium dense, damp, fine, yellowish-brown		12	6
400 - 10	 3/6 7/6 9/6				16	6
395 - 15	 4/6 9/6 14/6				23	6
			Bottom of Boring at 16.5 Feet			
390 - 20						
385 - 25						
380 - 30						

Notes:

Project: Fitch Park, Clark Realty

Project Number: TLB82604.01

Location: Monterey, CA

Date: 03/05/04

Logged By: D. Ledgerwood

Elevation: 435 Feet

Drilled By: S. Riley

Depth to Groundwater: N/E

Drill Type: CME 75

Cased to Depth: N/A

Auger Type: 8" O.D. Hollow Stem Auger

Hammer Type: Trip

ELEVATION/ DEPTH (feet)	SOIL SYMBOLS SAMPLER SYMBOLS AND FIELD TEST DATA	USCS	Soil Description	Remarks	N-value	Moisture Content %
435 0		SM	SAND, Silty; very loose, moist, fine to medium, brown with light-brown interbeds light-brown	DD = 101 pcf	--	11
430 5					4	10
425 10		SM	Medium dense, damp		13	6
420 15					22	6
415 20		SP-SM	SAND, Poorly Graded with Silt; medium dense, damp, fine to medium, yellowish-brown		27	5
410 25						
405 30			Bottom of Boring at 20 Feet			

Notes:

Project: Fitch Park, Clark Realty

Project Number: TLB82604.01

Location: Monterey, CA

Date: 03/05/04

Logged By: D. Ledgerwood

Elevation: 422 Feet

Drilled By: S. Riley

Depth to Groundwater: N/E

Drill Type: CME 75

Cased to Depth: N/A

Auger Type: 8" O.D. Hollow Stem Auger

Hammer Type: Trip

ELEVATION/ DEPTH (feet)	SOIL SYMBOLS SAMPLER SYMBOLS AND FIELD TEST DATA	USCS	Soil Description	Remarks	N-value	Moisture Content %
0		SM	SAND, Silty; loose, damp, fine, brown At 1 Foot - Light-brown		8	6
420			Very loose, moist, brown	DD = 101 pcf	--	14
5		SM	Medium dense		3	8
415			Light-brown	DD = 106 pcf	--	8
10		SM	Light-brown		11	8
410						
15		SP	SAND, Poorly Graded; medium dense, damp, fine to medium, yellowish- brown		18	4
405			Bottom of Boring at 16.5 Feet			
20						
400						
25						
395						
30						
390						

Notes:

Project: Fitch Park, Clark Realty

Project Number: TLB82604.01

Location: Monterey, CA

Date: 03/08/04

Logged By: D. Ledgerwood

Elevation: 407 Feet

Drilled By: T. Conley





Depth to Groundwater: N/E

Drill Type: CME 75

Cased to Depth: N/A

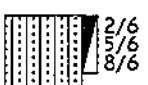
Auger Type: 6 5/8 " O.D. Hollow Stem Auger

Hammer Type: Trip

ELEVATION/ DEPTH (feet)	SOIL SYMBOLS SAMPLER SYMBOLS AND FIELD TEST DATA	USCS	Soil Description	Remarks	N-value	Moisture Content %
0		SM	SAND, Silty; medium dense, moist, brown		13	8
405		SP-SM	SAND, Poorly Graded with Silt; medium dense, moist, fine, yellowish-brown	DD = 96 pcf	--	7
5					11	9
400		SP	SAND, Poorly Graded; medium dense, moist, fine, yellowish-brown		24	7
10						
395			Damp		27	4
15						
390			Bottom of Boring at 16.5 Feet			
20						
385						
25						
380						
30						
375						

Notes:

Project: Fitch Park, Clark Realty

Project Number: TLB82604.01

Location: Monterey, CA

Date: 03/08/04

Logged By: D. Ledgerwood

Elevation: 389.5 Feet

Drilled By: T. Conley

Depth to Groundwater: N/E

Drill Type: CME 75

Cased to Depth: N/A

Auger Type: 6 5/8 " O.D. Hollow Stem Auger

Hammer Type: Trip

ELEVATION/ DEPTH (feet)	SOIL SYMBOLS SAMPLER SYMBOLS AND FIELD TEST DATA	USCS	Soil Description	Remarks	N-value	Moisture Content %
0		SM	SAND, Silty; loose, moist, dark-brown with light- brown	DD = 96 pcf $\phi = 30^\circ$ C = 58 psf	--	10
385 5			Dark-brown		6	11
380 10		SP	SAND, Poorly Graded; medium dense, damp, fine, yellowish-brown		18	3
375 15			Bottom of Boring at 15 Feet	14	3	
370 20						
365 25						
360 30						

Notes:

Project: Fitch Park, Clark Realty

Project Number: TLB82604.01

Location: Monterey, CA

Date: 03/08/04

Logged By: D. Ledgerwood

Elevation: 379 Feet

Drilled By: T. Conley

Depth to Groundwater: N/E

Drill Type: CME 75

Cased to Depth: N/A

Auger Type: 6 5/8 " O.D. Hollow Stem Auger

Hammer Type: Trip

ELEVATION/ DEPTH (feet)	SOIL SYMBOLS SAMPLER SYMBOLS AND FIELD TEST DATA	USCS	Soil Description	Remarks	N-value	Moisture Content %
0		SM	SAND, Silty; loose, moist, fine to medium, dark brown to brown (Fill?) Trace roots brown (Wood debris?)	DD = 102 pcf	--	12
375				DD = 103 pcf	--	10
5			Reddish-brown		9	11
370						
10		SP	Sand, Poorly Graded; medium dense, damp, fine, yellowish-brown		27	5
365						
15			Bottom of Boring at 20 Feet		25	5
360						
20						
355						
25						
350						
30						

Notes:

SOIL TEST BORING SYMBOLIC LOG

BORING B-27

Project: Fitch Park, Clark Realty

Location: Monterey, CA

Logged By: D. Ledgerwood

Drilled By: T. Conley

Drill Type: CME 75

Auger Type: 6 5/8 " O.D. Hollow Stem Auger

Project Number: TLB82604.01

Date: 03/08/04

Elevation: 378 Feet

Depth to Groundwater: N/E

Cased to Depth: N/A

Hammer Type: Trip

ELEVATION/ DEPTH (feet)	SOIL SYMBOLS SAMPLER SYMBOLS AND FIELD TEST DATA	USCS	Soil Description	Remarks	N-value	Moisture Content %
0		SM	SAND, Silty; medium dense, moist, fine, brown		15	8
375					DD = 111 pcf	--
5		SP	Damp, light-brown		24	3
370						
10		SP	SAND, Poorly Graded; dense, moist, fine, reddish-brown		31	6
365						
15			Medium dense, damp, yellowish-brown		20	3
360						
20			Bottom of Boring at 16.5 Feet			
355						
25						
350						
30						

Notes:

Project: Fitch Park, Clark Realty

Project Number: TLB82604.01

Location: Monterey, CA

Date: 03/08/04

Logged By: D. Ledgerwood

Elevation: 378 Feet

Drilled By: T. Conley

Depth to Groundwater: N/E

Drill Type: CME 75

Cased to Depth: N/A

Auger Type: 6 5/8 " O.D. Hollow Stem Auger

Hammer Type: Trip

ELEVATION/ DEPTH (feet)	SOIL SYMBOLS SAMPLER SYMBOLS AND FIELD TEST DATA	USCS	Soil Description	Remarks	N-value	Moisture Content %
0		SM	SAND, Silty; loose, moist, fine, brown		6	9
375			Light-brown	DD = 101 pcf	--	9
5					10	7
370						
10						
365		SP	SAND, Poorly Graded, medium dense, damp, fine to medium, light-brown		18	4
15			Bottom of Boring at 15 Feet			
360						
20						
355						
25						
350						
30						

Notes:

Project: Fitch Park, Clark Realty

Project Number: TLB82604.01

Location: Monterey, CA

Date: 03/08/04

Logged By: D. Ledgerwood

Elevation: 360 Feet

Drilled By: T. Conley

Depth to Groundwater: N/E

Drill Type: CME 75

Cased to Depth: N/A

Auger Type: 6 5/8 " O.D. Hollow Stem Auger

Hammer Type: Trip

ELEVATION/ DEPTH (feet)	SOIL SYMBOLS SAMPLER SYMBOLS AND FIELD TEST DATA	USCS	Soil Description	Remarks	N-value	Moisture Content %
360 - 0		SM	AC = 3 inches Base = 4.5 inches	DD = 108 pcf	--	5
355 - 5		SP-SM	SAND, Silty; medium dense, damp, fine to medium, reddish-brown		21	4
350 - 10		SP	SAND, Poorly Graded with Silt; medium dense, damp, fine to medium, reddish- brown At 3.5 Feet - Fine, yellowish-brown	DD = 99 pcf	--	2
345 - 15				SAND, Poorly Graded; medium dense, dry to damp, fine, yellowish- brown Fine to medium		20
340 - 20			Bottom of Boring at 16.5 Feet		29	5
335 - 25						
330 - 30						

Notes:

Project: Fitch Park, Clark Realty

Project Number: TLB82604.01

Location: Monterey, CA

Date: 03/08/04

Logged By: D. Ledgerwood

Elevation: 391 Feet

Drilled By: T. Conley





Depth to Groundwater: N/E

Drill Type: CME 75

Cased to Depth: N/A

Auger Type: 6 5/8 " O.D. Hollow Stem Auger

Hammer Type: Trip

ELEVATION/ DEPTH (feet)	SOIL SYMBOLS SAMPLER SYMBOLS AND FIELD TEST DATA	USCS	Soil Description	Remarks	N-value	Moisture Content %
0 390	 8/6 8/6 8/6	SM	SAND, Silty; medium dense, moist, fine, brown, roots		16	9
5 385	 4/6 5/6 6/6	SP- SM	SAND, Poorly Graded with Silt; medium dense, moist, fine to medium, reddish- brown	DD = 99 pcf -200 = 12%	-- 11	8 8
10 380	 5/6 7/6 9/6		Fine, light reddish-brown		16	8
15 375	 5/6 9/6 13/6	SP	SAND, Poorly Graded; medium dense, damp, fine to medium, yellowish- brown		22	4
20 370	 7/6 12/6 14/6				26	4
25 365			Bottom of Boring at 21.5 Feet			
30 360						

Notes:

Project: Fitch Park, Clark Realty

Project Number: TLB82604.01

Location: Monterey, CA

Date: 03/08/04

Logged By: D. Ledgerwood

Elevation: 364 Feet

Drilled By: T.Conley

Depth to Groundwater: N/E

Drill Type: CME 75

Cased to Depth: N/A

Auger Type: 6 5/8 " O.D. Hollow Stem Auger

Hammer Type: Trip

ELEVATION/ DEPTH (feet)	SOIL SYMBOLS SAMPLER SYMBOLS AND FIELD TEST DATA	USCS	Soil Description	Remarks	N-value	Moisture Content %
0		SM	SAND, Silty; loose, moist, fine, brown to dark brown		9	9
360			Increase in moisture, fine to medium	DD = 101 pcf	--	13
5			Decrease in moisture, yellowish-brown		9	8
355			Medium dense		23	7
10			Bottom of Boring at 15 Feet			
350						
15						
345						
20						
340						
25						
335						
30						

Notes:

Project: Fitch Park, Clark Realty

Project Number: TLB82604.01

Location: Monterey, CA

Date: 03/08/04

Logged By: D. Ledgerwood

Elevation: 366 Feet

Drilled By: T. Conley

Depth to Groundwater: N/E

Drill Type: CME 75

Cased to Depth: N/A

Auger Type: 6 5/8 " O.D. Hollow Stem Auger

Hammer Type: Trip

ELEVATION/ DEPTH (feet)	SOIL SYMBOLS SAMPLER SYMBOLS AND FIELD TEST DATA	USCS	Soil Description	Remarks	N-value	Moisture Content %
0						
365		SM	AC = 3 inches Base = 5.5 inches SAND, Silty; dense, damp, fine, brown Loose, moist, dark reddish-brown	DD = 117 pcf	34	6
5						
360						
10		SP	SAND, Poorly Graded; loose, damp, fine, yellowish- brown		9	6
355						
15						
350					15	6
20						
345						
25						
340						
30						
335						
			Bottom of Boring at 16.5 Feet			

Notes:

Project: Fitch Park, Clark Realty

Project Number: TLB82604.01

Location: Monterey, CA

Date: 03/08/04

Logged By: D. Ledgerwood

Elevation: 360 Feet

Drilled By: T.Conley





Depth to Groundwater: N/E

Drill Type: CME 75

Cased to Depth: N/A

Auger Type: 6 5/8 " O.D. Hollow Stem Auger

Hammer Type: Trip

ELEVATION/ DEPTH (feet)	SOIL SYMBOLS SAMPLER SYMBOLS AND FIELD TEST DATA	USCS	Soil Description	Remarks	N-value	Moisture Content %
360 - 0		SM	SAND, Silty; loose, moist, fine to medium, dark- brown with roots		8	8
355 - 5			Medium dense, some 3/8" roots, brown	DD = 101 pcf	--	8
			No roots		12	8
350 - 10		SP	SAND, Poorly Graded; medium dense, damp, fine, reddish-brown		13	5
345 - 15			Fine to medium, yellowish-brown		24	3
340 - 20			Bottom of Boring at 16.5 Feet			
335 - 25						
330 - 30						

Notes:

Project: Fitch Park, Clark Realty

Project Number: TLB82604.01

Location: Monterey, CA

Date: 03/08/04

Logged By: D. Ledgerwood

Elevation: 344 Feet

Drilled By: T.Conley

Depth to Groundwater: N/E

Drill Type: CME 75

Cased to Depth: N/A

Auger Type: 6 5/8 " O.D. Hollow Stem Auger

Hammer Type: Trip

ELEVATION/ DEPTH (feet)	SOIL SYMBOLS SAMPLER SYMBOLS AND FIELD TEST DATA	USCS	Soil Description	Remarks	N-value	Moisture Content %
0		SM	SAND, Silty; loose, damp, fine, brown to dark-brown	DD = 104 pcf	--	9
340			Slight decrease in percent silt, brown		7	9
5			Medium dense, brown to light-brown		14	6
335					15	8
10						
330						
15			Bottom of Boring at 15 Feet			
325						
20						
320						
25						
315						
30						

Notes:

Project: Fitch Park, Clark Realty

Project Number: TLB82604.01

Location: Monterey, CA

Date: 03/08/04

Logged By: D. Ledgerwood

Elevation: 338 Feet

Drilled By: T. Conley

Depth to Groundwater: N/E

Drill Type: CME 75

Cased to Depth: N/A

Auger Type: 6 5/8 " O.D. Hollow Stem Auger

Hammer Type: Trip

ELEVATION/ DEPTH (feet)	SOIL SYMBOLS SAMPLER SYMBOLS AND FIELD TEST DATA	USCS	Soil Description	Remarks	N-value	Moisture Content %
0		SM	SAND, Silty; medium dense, moist, fine, trace fine roots, brown to dark- brown At 1.5 Feet - No roots Loose Damp, brown	DD = 110 pcf	--	11
335				DD = 107 pcf	--	7
5				DD = 107 pcf	10	6
330					5	5
10						
325		SP- SM	SAND, Poorly Graded with Silt; medium dense, moist, fine to medium, yellowish- brown Bottom of Boring at 15 Feet		17	11
15						
320						
20						
315						
25						
310						
30						

Notes:

SOIL TEST BORING SYMBOLIC LOG

BORING B-36

Project: Fitch Park, Clark Realty

Project Number: TLB82604.01

Location: Monterey, CA

Date: 03/08/04

Logged By: D. Ledgerwood

Elevation: 346 Feet

Drilled By: T. Conley







Depth to Groundwater: N/E

Drill Type: CME 75

Cased to Depth: N/A

Auger Type: 6 5/8 " O.D. Hollow Stem Auger

Hammer Type: Trip

ELEVATION/ DEPTH (feet)	SOIL SYMBOLS SAMPLER SYMBOLS AND FIELD TEST DATA	USCS	Soil Description	Remarks	N-value	Moisture Content %
0						
345	 3/6 6/6 6/6	SM	SAND, Silty; medium dense, moist, fine to medium, dark yellowish-brown to brown		12	8
				DD = 104 pcf	--	7
5						
340	 5/6 6/6 5/6	SP	SAND, Poorly Graded, medium dense, damp, fine, yellowish-brown		11	5
10						
335	 4/6 6/6 6/6	SM	SAND, Silty; medium dense, moist, yellowish-brown to light reddish-brown		12	7
15						
330	 4/6 7/6 10/6	SP	SAND, Poorly Graded; medium dense, damp, yellowish-brown		17	4
20						
325	 6/6 12/6 15/6				27	3
25						
320	 5/6 10/6 12/6				22	3
30						
315	 5/6 10/6 13/6				23	3

Notes:

Project: Fitch Park, Clark Realty

Project Number: TLB82604.01

Location: Monterey, CA

Date: 03/08/04

Logged By: D. Ledgerwood

Elevation: 346 Feet

Drilled By: T. Conley

Depth to Groundwater: N/E

Drill Type: CME 75

Cased to Depth: N/A

Auger Type: 6 5/8 " O.D. Hollow Stem Auger

Hammer Type: Trip

ELEVATION/ DEPTH (feet)	SOIL SYMBOLS SAMPLER SYMBOLS AND FIELD TEST DATA	USCS	Soil Description	Remarks	N-value	Moisture Content %
310					23	3
305					29	3
300						
295			Dense		36	4
290			Bottom of Boring at 51.5 Feet			
285						
65						

Notes:

Project: Fitch Park, Clark Realty

Project Number: TLB82604.01

Location: Monterey, CA

Date: 03/09/04

Logged By: D. Ledgerwood

Elevation: 356 Feet

Drilled By: T. Conley



Depth to Groundwater: N/E

Drill Type: CME 75

Cased to Depth: N/A

Auger Type: 6 5/8 " O.D. Hollow Stem Auger

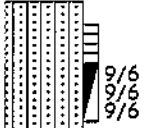
Hammer Type: Trip

ELEVATION/ DEPTH (feet)	SOIL SYMBOLS SAMPLER SYMBOLS AND FIELD TEST DATA	USCS	Soil Description	Remarks	N-value	Moisture Content %
0						
355		SM	AC = 3 inches Base = 8 inches SAND, Silty; medium dense, damp, fine, brown	DD = 108 pcf -200 = 19%	--	5
5					18	4
350						
10			Moist, light reddish-brown		22	7
345						
15		SP	SAND, Poorly Graded; medium dense, damp, yellowish-brown		20	4
340			Bottom of Boring at 15 Feet			
20						
335						
25						
330						
30						
325						

Notes:

SOIL TEST BORING SYMBOLIC LOG

BORING B-38

Project: Fitch Park, Clark Realty

Project Number: TLB82604.01

Location: Monterey, CA

Date: 03/09/04

Logged By: D. Ledgerwood

Elevation: 346 Feet

Drilled By: T. Conley

Depth to Groundwater: N/E

Drill Type: CME 75

Cased to Depth: N/A

Auger Type: 6 5/8 " O.D. Hollow Stem Auger

Hammer Type: Trip

ELEVATION/ DEPTH (feet)	SOIL SYMBOLS SAMPLER SYMBOLS AND FIELD TEST DATA	USCS	Soil Description	Remarks	N-value	Moisture Content %
0						
345	2/6 2/6 3/6	SM	SAND, Silty; loose, moist, dark-brown	-200 = 13%	5	8
			Brown	DD = 109 pcf	--	10
5						
340	3/6 2/6 3/6				5	12
10	3/6 3/6 4/6	SP- SM	SAND, Poorly Graded with Silt; loose, moist, reddish- brown		7	8
335						
15	4/6 8/6 12/6	SP	SAND, Poorly Graded; medium dense, damp, fine, yellowish-brown		20	5
330						
			Bottom of Boring at 16.5 Feet			
20						
325						
25						
320						
30						
315						

Notes:

Project: Fitch Park, Clark Realty

Project Number: TLB82604.01

Location: Monterey, CA

Date: 03/09/04

Logged By: D. Ledgerwood

Elevation: 352 Feet

Drilled By: T. Conley

Depth to Groundwater: N/E

Drill Type: CME 75

Cased to Depth: N/A

Auger Type: 6 5/8 " O.D. Hollow Stem Auger

Hammer Type: Trip

ELEVATION/ DEPTH (feet)	SOIL SYMBOLS SAMPLER SYMBOLS AND FIELD TEST DATA	USCS	Soil Description	Remarks	N-value	Moisture Content %
0		SM	AC = 3 inches Base = 5.5 inches SAND, Silty; medium dense, damp, fine, brown		16	4
350				DD = 101 pcf	--	4
5		SP	SAND, Poorly Graded; loose, damp, fine, yellowish- brown		7	4
345			Medium dense		20	3
340			Bottom of Boring at 15 Feet			
15						
335						
20						
330						
25						
325						
30						
320						

Notes:

Project: Fitch Park, Clark Realty

Project Number: TLB82604.01

Location: Monterey, CA

Date: 03/09/04

Logged By: D. Ledgerwood

Elevation: 392 Feet

Drilled By: T. Conley

Depth to Groundwater: N/E

Drill Type: CME 75

Cased to Depth: N/A

Auger Type: 6 5/8 " O.D. Hollow Stem Auger

Hammer Type: Trip

ELEVATION/ DEPTH (feet)	SOIL SYMBOLS SAMPLER SYMBOLS AND FIELD TEST DATA	USCS	Soil Description	Remarks	N-value	Moisture Content %
0		SM	SAND, Silty; very loose, moist, fine, brown to dark-brown At 1.5 Feet - Moist, brown	DD = 102 pcf	--	8
390					4	8
5						
385						
10		SP-SM	SAND, Poorly Graded with Silt; medium dense, damp, fine, yellowish-brown	DD = 108 pcf	--	9
380					17	6
15						
375		SM	SAND, Silty; dense, moist, fine, yellowish-brown		24	5
20					29	5
370						
25		SM	SAND, Silty; dense, moist, fine, yellowish-brown		35	8
365						
30						
360			Reddish-brown		32	12
			Bottom of Boring at 31.5 Feet			

Notes:

Project: Fitch. Park, Clark Realty

Location: Monterey, CA

Logged By: D. Ledgerwood

Drilled By: T.Conley

Drill Type: CME 75

Auger Type: 6 5/8 " O.D. Hollow Stem Auger

Project Number: TLB82604.01

Date: 03/08/04 and 03/10/04

Elevation: 441 Feet

Depth to Groundwater: N/E

Cased to Depth: N/A

Hammer Type: Trip

ELEVATION/ DEPTH (feet)	SOIL SYMBOLS SAMPLER SYMBOLS AND FIELD TEST DATA	USCS	Soil Description	Remarks	N-value	Moisture Content %
440	14/6 20/6	SM	AC = 3 inches Base = 6 inches SAND, Silty; dense, damp, fine, brown	DD = 112 pcf	34	3
435	9/6 10/6 11/6		Medium dense Reddish-brown	DD = 102 pcf $\Phi = 32^\circ$ C = 92 psf	-- 21	6 6
430						
425	7/6 10/6 12/6		Yellowish-brown, decrease in fines		22	6
420	5/6 6/6 9/6				15	6
415	5/6 8/6 10/6				18	6
410	9/6 15/6 18/6		Moist, fine to medium		33	9

Notes:

Project: Fitch Park, Clark Realty

Project Number: TLB82604.01

Location: Monterey, CA

Date: 03/08/04 and 03/10/04

Logged By: D. Ledgerwood

Elevation: 441 Feet

Drilled By: T. Conley

Depth to Groundwater: N/E

Drill Type: CME 75

Cased to Depth: N/A

Auger Type: 6 5/8 " O.D. Hollow Stem Auger

Hammer Type: Trip

ELEVATION/ DEPTH (feet)	SOIL SYMBOLS SAMPLER SYMBOLS AND FIELD TEST DATA	USCS	Soil Description	Remarks	N-value	Moisture Content %
35 405	12/6 22/6 27/6		Dense, reddish-brown		49	10
40 400	13/6 25/6 33/6		Very dense, fine to medium, dark reddish-brown		58	10
45 395						
50 390	12/6 27/6 34/6	SP	SAND, Poorly Graded; very dense, damp, fine, yellowish-brown		61	5
			Bottom of Boring at 50 Feet			
55 385						
60 380						
65						

Notes:

Project: Fitch Park, Clark Realty

Project Number: TLB82604.01

Location: Monterey, CA

Date: 03/09/04

Logged By: D. Ledgerwood

Elevation: 434 Feet

Drilled By: T. Conley

Depth to Groundwater: N/E

Drill Type: CME 75

Cased to Depth: N/A

Auger Type: 6 5/8 " O.D. Hollow Stem Auger

Hammer Type: Trip

ELEVATION/ DEPTH (feet)	SOIL SYMBOLS SAMPLER SYMBOLS AND FIELD TEST DATA	USCS	Soil Description	Remarks	N-value	Moisture Content %
0						
430	8/6 7/6 6/6	SM	AC = 3 inches Base = 5 inches SAND, Silty; medium dense, damp, fine, light-brown		13	4
5		SP	SAND, Poorly Graded; medium dense, damp, fine, yellowish-brown	DD = 97 pcf	--	4
425	5/6 5/6 9/6	SM	SAND, Silty; medium dense, moist, fine, yellowish- brown to light-brown		15	6
10						
420	6/6 11/6 16/6				27	6
15						
415	10/6 15/6 20/6		Dense, fine to medium, reddish-brown		35	9
20						
410	9/6 13/6 17/6		Medium dense, fine, yellowish-brown		30	7
25						
405	9/6 18/6 25/6		Dense, fine to medium		43	6
30						
			Bottom of Boring at 30 Feet			

Notes:

SOIL TEST BORING SYMBOLIC LOG

BORING B-43

Project: Fitch Park, Clark Realty

Project Number: TLB82604.01

Location: Monterey, CA

Date: 03/09/04

Logged By: D. Ledgerwood

Elevation: 412 Feet

Drilled By: T. Conley

Depth to Groundwater: N/E

Drill Type: CME 75

Cased to Depth: N/A

Auger Type: 6 5/8 " O.D. Hollow Stem Auger

Hammer Type: Trip

ELEVATION/ DEPTH (feet)	SOIL SYMBOLS SAMPLER SYMBOLS AND FIELD TEST DATA	USCS	Soil Description	Remarks	N-value	Moisture Content %
0						
410	17/6 18/6	SP	AC = 3 inches Base = 5 inches SAND, Poorly Graded; dense, damp, fine to medium, light brown	DD = 102 pcf	35	4
5	6/6 11/6 12/6	SM	SAND, Silty; medium dense, moist, fine to medium, reddish-brown		23	10
405						
10	9/6 16/6 18/6	SP	SAND, Poorly Graded; dense, damp, fine, yellowish-brown		34	5
400						
15	8/6 12/6 13/6		Medium dense		25	5
395						
20	7/6 15/6 18/6		Dense, dry		33	2
390			Bottom of Boring at 21.5 Feet			
25						
385						
30						
380						

Notes:

Project: Fitch Park, Clark Realty

Project Number: TLB82604.01

Location: Monterey, CA

Date: 03/09/04

Logged By: D. Ledgerwood

Elevation: 372 Feet

Drilled By: T. Conley

Depth to Groundwater: N/E

Drill Type: CME 75

Cased to Depth: N/A

Auger Type: 6 5/8 " O.D. Hollow Stem Auger

Hammer Type: Trip

ELEVATION/ DEPTH (feet)	SOIL SYMBOLS SAMPLER SYMBOLS AND FIELD TEST DATA	USCS	Soil Description	Remarks	N-value	Moisture Content %
0						
370	7/6 9/6 10/6	SP	AC = 3.5 inches Base = 5 inches SAND, Poorly Grade; medium dense, damp, fine, yellowish-brown with some interbeds of reddish-brown silty fine sand	DD = 101 pcf	19	6
5	5/6 7/6 10/6	SM	SAND, Silty; medium dense, damp to moist, fine, yellowish-brown		17	9
365						
10	6/6 15/6 18/6	SP	SAND, Poorly Graded; dense, moist, fine, yellowish-brown		33	7
360						
15	5/6 6/6 7/6	SP- SM	SAND, Poorly Graded with Silt; medium dense, moist, fine, yellowish-brown		13	6
355			Bottom of Boring at 16.5 Feet			
20						
350						
25						
345						
30						
340						

Notes:

Project: Fitch Park, Clark Realty

Project Number: TLB82604.01

Location: Monterey, CA

Date: 03/10/04

Logged By: D. Ledgerwood

Elevation: 388 Feet

Drilled By: T. Conley

Depth to Groundwater: N/E

Drill Type: CME 75

Cased to Depth: N/A

Auger Type: 6 5/8 " O.D. Hollow Stem Auger

Hammer Type: Trip

ELEVATION/ DEPTH (feet)	SOIL SYMBOLS SAMPLER SYMBOLS AND FIELD TEST DATA	USCS	Soil Description	Remarks	N-value	Moisture Content %
0			AC = 2.5 inches Base = 6.5 inches			
385	5/6 6/6 8/6	SM	SAND, Silty; medium dense, moist, fine, light-brown At 3 Feet - Damp, trace silt	DD = 99 pcf	--	10
5					14	5
380	13/6 50/6		Very dense, moist, increase in fines, brown to grayish-brown	DD = 122 pcf	>63	8
10						
375	8/6 10/6 14/6		Medium dense, decrease in fines, yellowish-brown		24	7
15						
370	10/6 13/6 16/6		Reddish-brown		29	7
20						
365	11/6 15/6 20/6		Dense, increase in moisture, fine to medium, trace clay, reddish-brown		35	11
25						
360	10/6 24/6 27/6	SP	SAND, Poorly Graded; very dense, damp, fine, yellowish-brown		51	4
30			Bottom of Boring at 30 Feet			

Notes:

Project: Fitch Park, Clark Realty

Project Number: TLB82604.01

Location: Monterey, CA

Date: 03/10/04

Logged By: D. Ledgerwood

Elevation: 375 Feet

Drilled By: T. Conley

Depth to Groundwater: N/E

Drill Type: CME 75

Cased to Depth: N/A

Auger Type: 6 5/8 " O.D. Hollow Stem Auger.

Hammer Type: Trip

ELEVATION/ DEPTH (feet)	SOIL SYMBOLS SAMPLER SYMBOLS AND FIELD TEST DATA	USCS	Soil Description	Remarks	N-value	Moisture Content %
375 - 0	12/6 12/6 10/6	SM	AC = 3 inches Base = 5 inches SAND, Silty; medium dense, moist, light-brown		22	8
370 - 5	4/6 4/6 6/6	SP- SM	SAND, Poorly Graded with Silt; loose, damp, fine, yellowish-brown	DD = 98 pcf -200 = 10%	--	4
365 - 10	8/6 13/6 19/6		Dense		10	5
360 - 15	6/6 12/6 16/6	SM	SAND, Silty; medium dense, moist, fine, yellowish- brown, micaceous		32	4
355 - 20	24/6 25/6 22/6		Dense, some weak cementation, increase in fines, pale reddish-brown		28	6
350 - 25			Bottom of Boring at 21.5 Feet		47	9
345 - 30						

Notes:

SOIL TEST BORING SYMBOLIC LOG

BORING B-47

Project: Fitch Park, Clark Realty

Project Number: TLB82604.01

Location: Monterey, CA

Date: 03/10/04

Logged By: D. Ledgerwood

Elevation: 362 Feet

Drilled By: T.Conley

Depth to Groundwater: N/E

Drill Type: CME 75

Cased to Depth: N/A

Auger Type: 6 5/8 " O.D. Hollow Stem Auger

Hammer Type: Trip

ELEVATION/ DEPTH (feet)	SOIL SYMBOLS SAMPLER SYMBOLS AND FIELD TEST DATA	USCS	Soil Description	Remarks	N-value	Moisture Content %
0						
360	4/6 7/6 12/6	SM	AC = 3.5 inches Base = 5 inches SAND, Silty; medium dense, moist, fine, yellowish- brown to reddish-brown		19	6
5		SP- SM	SAND, Poorly Graded with Silt; medium dense, moist, fine, dark yellowish-brown	DD = 100 pcf	--	6
355	5/6 7/6 10/6				17	6
10						
350						
15	9/6 15/6 19/6	SP	SAND, Poorly Graded; dense, damp, fine to medium, yellowish-brown		34	3
345			Bottom of Boring at 15 Feet			
20						
340						
25						
335						
30						
330						

Notes:

Project: Fitch Park, Clark Realty

Project Number: B82604.01

Location: Monterey, CA

Date: 03/10/04

Logged By: D. Ledgerwood

Elevation: 348 Feet

Drilled By: T. Conley

Depth to Groundwater: N/E

Drill Type: CME 75

Cased to Depth: N/A

Auger Type: 6 5/8 " O.D. Hollow Stem Auger

Hammer Type: Trip

ELEVATION/ DEPTH (feet)	SOIL SYMBOLS SAMPLER SYMBOLS AND FIELD TEST DATA	USCS	Soil Description	Remarks	N-values blows/ft.	Moisture Content %	
0		SM	AC = 3.5 inches	DD = 112 pcf	--	8	
345			Base = 4.5 inches				SAND, Silty; medium dense, moist, fine to medium, minor amounts of wood, brown to grayish-brown (FILL)
5			At 2 Feet - Gray At 3 Feet - Dark-gray to black Reddish-brown				
340		SP	SAND, Poorly Graded; medium, dense, damp, fine, yellowish-brown	19	4		
335			Bottom of Boring at 15 Feet				
330							
20							
325							
320							
30							

Notes:

Project: Fitch Park, Clark Realty

Project Number: TLB82604.01

Location: Monterey, CA

Date: 03/10/04

Logged By: D. Ledgerwood

Elevation: 338 Feet

Drilled By: T. Conley

Depth to Groundwater: N/E

Drill Type: CME 75

Cased to Depth: N/A

Auger Type: 6 5/8 " O.D. Hollow Stem Auger

Hammer Type: Trip

ELEVATION/ DEPTH (feet)	SOIL SYMBOLS SAMPLER SYMBOLS AND FIELD TEST DATA	USCS	Soil Description	Remarks	N-value	Moisture Content %
0		SM	SAND, Silty; very loose, moist, fine, brown to dark-brown		4	7
335			Loose, decrease in percent silt, reddish-brown	DD = 111 pcf φ = 33° C = 46 psf	--	9
5		SP	SAND, Poorly Graded; loose, moist, fine, reddish-brown		7	6
330			Medium dense, dry, fine to medium, yellowish-brown			
10					18	2
325						
15					19	2
320						
20			Damp		22	3
315			Bottom of Boring at 21.5 Feet			
25						
310						
30						

Notes:

Project: Fitch Park, Clark Realty

Project Number: TLB82604.01

Location: Monterey, CA

Date: 03/10/04

Logged By: D. Ledgerwood

Elevation: 350 Feet

Drilled By: T. Conley

Depth to Groundwater: N/E

Drill Type: CME 75

Cased to Depth: N/A

Auger Type: 6 5/8 " O.D. Hollow Stem Auger

Hammer Type: Trip

ELEVATION/ DEPTH (feet)	SOIL SYMBOLS SAMPLER SYMBOLS AND FIELD TEST DATA	USCS	Soil Description	Remarks	N-value	Moisture Content %
350 0		SM	SAND, Silty; medium dense, moist, fine to medium, dark-brown to brown with roots Trace 1/4" roots	DD = 106 pcf	-- 24	15 7
345 5			Dark-brown	DD = 112 pcf	--	8
340 10		SP	SAND, Poorly Graded; loose, damp, fine, yellowish-brown		4	5
335 15			Medium dense		12	4
330 20			Bottom of Boring at 15 Feet			
325 25						
320 30						

Notes:

Project: Fitch Park, Clark Realty

Project Number: TLB82604.01

Location: Monterey, CA

Date: 03/10/04

Logged By: D. Ledgerwood

Elevation: 352 Feet

Drilled By: T. Conley

Depth to Groundwater: N/E

Drill Type: CME 75

Cased to Depth: N/A

Auger Type: 6 5/8 " O.D. Hollow Stem Auger

Hammer Type: Trip

ELEVATION/ DEPTH (feet)	SOIL SYMBOLS SAMPLER SYMBOLS AND FIELD TEST DATA	USCS	Soil Description	Remarks	N-value	Moisture Content %
0		SM	SAND, Silty; very loose, moist, fine, brown		4	6
350			Reddish-brown	DD = 103 pcf	--	7
5						
345		SP- SM	SAND, Poorly Graded with Silt; loose, moist, fine, yellowish-brown		9	6
10						
340			Medium dense, slight increase in fines		12	7
15			Bottom of Boring at 15 Feet			
335						
20						
330						
25						
325						
30						
320						

Notes:

Project: Fitch Park, Clark Realty

Project Number: TLB82604.01

Location: Monterey, CA

Date: 03/10/04

Logged By: D. Ledgerwood

Elevation: 350 Feet

Drilled By: T. Conley

Depth to Groundwater: N/E

Drill Type: CME 75

Cased to Depth: N/A

Auger Type: 6 5/8 " O.D. Hollow Stem Auger

Hammer Type: Trip

ELEVATION/ DEPTH (feet)	SOIL SYMBOLS SAMPLER SYMBOLS AND FIELD TEST DATA	USCS	Soil Description	Remarks	N-value	Moisture Content %
350 0		SM	AC = 3.5 inches Base = 4 inches SAND, Silty; loose, moist, fine, brown	DD = 104 pcf	--	6
345 5					7	6
340 10		SP	SAND, Poorly Graded; medium dense, damp, fine, yellowish-brown		12	4
335 15			Bottom of Boring at 15 Feet		17	3
330 20						
325 25						
320 30						

Notes:

Project: Fitch Park, Clark Realty

Project Number: TLB82604.01

Location: Monterey, CA

Date: 03/10/04

Logged By: D. Ledgerwood

Elevation: 358 Feet

Drilled By: T. Conley

Depth to Groundwater: N/E

Drill Type: CME 75

Cased to Depth: N/A

Auger Type: 6 5/8 " O.D. Hollow Stem Auger

Hammer Type: Trip

ELEVATION/ DEPTH (feet)	SOIL SYMBOLS SAMPLER SYMBOLS AND FIELD TEST DATA	USCS	Soil Description	Remarks	N-value	Moisture Content %
0			AC = 2.5 inches Base = 6 inches			
355	15/6 17/6 12/6	SM	SAND, Silty; medium dense, damp, fine, brown	DD = 100 pcf	29	5
5	4/6 6/6 6/6	SP- SM	SAND, Poorly Graded with Silt; medium dense, dry, fine, light brown		--	2
350		SM	SAND, Silty; medium dense, damp, fine, yellowish- brown to reddish-brown		12	4
10	4/6 7/6 8/6	SP	SAND, Poorly Graded; medium dense, damp, fine, yellowish-brown		15	4
345						
15	5/6 8/6 12/6	SP- SM	SAND, Poorly Graded with Silt; medium dense, damp, fine, yellowish-brown		20	3
340			Bottom of Boring at 16.5 Feet			
20						
335						
25						
330						
30						

Notes:

Project: Fitch Park, Clark Realty

Project Number: TLB82604.01

Location: Monterey, CA

Date: 03/10/04

Logged By: D. Ledgerwood

Elevation: 343 Feet

Drilled By: T. Conley

Depth to Groundwater: N/E

Drill Type: CME 75

Cased to Depth: N/A

Auger Type: 6 5/8 " O.D. Hollow Stem Auger

Hammer Type: Trip

ELEVATION/ DEPTH (feet)	SOIL SYMBOLS SAMPLER SYMBOLS AND FIELD TEST DATA	USCS	Soil Description	Remarks	N-value	Moisture Content %	
0		SM	AC = 3.5 inches Base = 5 inches SAND, Silty; medium dense, moist, fine, brown to dark-brown Very dense; damp, increase in fines, dark-brown	DD = 110 pcf	28	6	
340					53	3	
5							
335							
10			Medium dense, slight decrease in percent silt, some weak cementation, brown to reddish-brown		20	4	
330							
15		SP	SAND, Poorly Graded; medium dense, damp, fine, yellowish-brown		12	3	
325			Bottom of Boring at 16.5 Feet				
20							
320							
25							
315							
30							

Notes:

Project: Fitch Park, Clark Realty

Project Number: TLB82604.01

Location: Monterey, CA

Date: 03/09/04

Logged By: D. Ledgerwood

Elevation: 346 Feet

Drilled By: T. Conley

Depth to Groundwater: N/E

Drill Type: CME 75

Cased to Depth: N/A

Auger Type: 6 5/8 " O.D. Hollow Stem Auger

Hammer Type: Trip

ELEVATION/ DEPTH (feet)	SOIL SYMBOLS SAMPLER SYMBOLS AND FIELD TEST DATA	USCS	Soil Description	Remarks	N-value	Moisture Content %
0						
345	1/6 3/6 5/6	SM	SAND, Silty; loose, moist, fine to medium, dark- brown to brown		8	7
			Fine, brown	DD = 102 pcf	--	7
5						
340	2/6 4/6 4/6				8	9
10						
335	5/6 6/6 7/6		Medium dense, increase in moisture, reddish-brown		13	12
15		SP	SAND, Poorly Graded; medium dense, moist, fine to medium, yellowish- brown	-200 = 5%	17	6
330	4/6 7/6 10/6					
20						
325	5/6 10/6 15/6		Damp, fine, yellowish- brown		25	4
			Bottom of Boring at 21.5 Feet			
25						
320						
30						
315						

Notes:

Project: Fitch Park, Clark Realty

Project Number: TLB82604.01

Location: Monterey, CA

Date: 03/09/04

Logged By: D. Ledgerwood

Elevation: 331 Feet

Drilled By: T. Conley

Depth to Groundwater: N/E

Drill Type: CME 75

Cased to Depth: N/A

Auger Type: 6 5/8 " O.D. Hollow Stem Auger

Hammer Type: Trip

ELEVATION/ DEPTH (feet)	SOIL SYMBOLS SAMPLER SYMBOLS AND FIELD TEST DATA	USCS	Soil Description	Remarks	N-value	Moisture Content %	
0		SM	SAND, Silty; loose, moist, fine, brown	DD = 104 pcf	--	7	
330						7	
5						6	
325							
10		SP	SAND, Poorly Graded; medium dense, moist, fine, yellowish-brown		20	6	
320							
15	SP- SM	SAND, Poorly Graded with Silt; medium dense, damp, fine, yellowish-brown		19	5		
315							
20	SP	SAND, Poorly Graded; medium dense, damp, fine to medium, yellowish- brown		28	3		
310							
25			Fine		26	5	
305							
30			Dense, fine to medium		35	4	
300			Bottom of Boring at 30 Feet				

Notes:

Project: Fitch Park, Clark Realty

Project Number: TLB82604.01

Location: Monterey, CA

Date: 03/09/04

Logged By: D. Ledgerwood

Elevation: 318 Feet

Drilled By: T. Conley

Depth to Groundwater: N/E

Drill Type: CME 75

Cased to Depth: N/A

Auger Type: 6 5/8 " O.D. Hollow Stem Auger

Hammer Type: Trip

ELEVATION/ DEPTH (feet)	SOIL SYMBOLS SAMPLER SYMBOLS AND FIELD TEST DATA	USCS	Soil Description	Remarks	N-value	Moisture Content %
0	3/6 4/6 4/6	SM	SAND, Silty; loose, moist, fine, brown to dark-brown		8	7
315			Medium dense, brown	DD = 104 pcf φ = 31° C = 124 psf	--	8
5	4/6 6/6 6/6		Yellowish-brown to reddish-brown		12	8
310						
10	5/6 7/6 9/9				16	8
305						
15	6/6 10/6 9/6	SP- SM	SAND, Poorly Graded with Silt; medium dense, damp, fine, yellowish-brown		19	5
300			Dense			
20	6/6 14/6 17/6				31	4
295						
25	4/6 13/6 18/6	SP	SAND, Poorly Graded; dense, damp, fine, yellowish-brown		31	3
290						
30	6/6 14/6 17/6				31	4

Notes:

Project: Fitch Park, Clark Realty

Project Number: TLB82604.01

Location: Monterey, CA

Date: 03/09/04

Logged By: D. Ledgerwood

Elevation: 318 Feet

Drilled By: T. Conley

Depth to Groundwater: N/E

Drill Type: CME 75

Cased to Depth: N/A

Auger Type: 6 5/8 " O.D. Hollow Stem Auger

Hammer Type: Trip

ELEVATION/ DEPTH (feet)	SOIL SYMBOLS SAMPLER SYMBOLS AND FIELD TEST DATA	USCS	Soil Description	Remarks	N-value	Moisture Content %
285						
35					35	4
280						
40					34	4
275						
45						
270						
50		SP- SM	SAND, Poorly Graded with Silt; dense, damp, fine, yellowish-brown		36	5
265			Bottom of Boring at 51.5 Feet			
55						
260						
60						
255						
65						

Notes:

Project: Fitch Park, Clark Realty

Project Number: TLB82604.01

Location: Monterey, CA

Date: 03/09/04

Logged By: D. Ledgerwood

Elevation: 330.5 Feet

Drilled By: T. Conley

Depth to Groundwater: N/E

Drill Type: CME 75

Cased to Depth: N/A

Auger Type: 6 5/8 " O.D. Hollow Stem Auger

Hammer Type: Trip

ELEVATION/ DEPTH (feet)	SOIL SYMBOLS SAMPLER SYMBOLS AND FIELD TEST DATA	USCS	Soil Description	Remarks	N-value	Moisture Content %	
330		SM	AC = 3 inches Base = 6 inches SAND, silty; medium dense, damp to moist, fine, yellowish-brown		11	5	
325				DD = 98 pcf	--	6	
						17	8
315		SP- SM	SAND, Poorly Graded with Silt; medium dense, moist, fine, yellowish-brown		26	6	
310			Damp		26	4	
310			Bottom of Boring at 20 Feet				
305							
300							

Notes:

APPENDIX C

RESULTS OF LABORATORY TESTS

This appendix contains the individual results of the following tests. The results of the moisture content and dry density tests are included on the test boring logs in Appendix B. These data, along with the field observations, were used to prepare the final test boring logs in Appendix B.

These Included:	Number of Tests:	To Determine:
Natural Moisture (ASTM D2216)	323	Moisture contents representative of field conditions at the time the sample was taken.
Natural Density (ASTM D2216)	69	Dry unit weight of sample representative of in-situ or in-place undisturbed condition.
Consolidation (ASTM D2435)	12	The amount and rate at which a soil sample compresses when loaded, and the influence of saturation on its behavior.
Moisture-Density Relationship (ASTM D1557)	4	The optimum (best) moisture content for compacting soil and the maximum dry unit weight (density) for a given compactive effort.
R-Value (ASTM D2844)	30	The capacity of a subgrade or subbase to support a pavement section designed to carry a specified traffic load.

These Included:	Number of Tests:	To Determine:
Grain-Size Distribution (ASTM D422)	8	Size and distribution of soil particles, i.e., clay, silt, sand, and gravel.
Direct Shear (ASTM D3080)	6	Soil shearing strength under varying loads and/or moisture conditions.
Sulfate Content (ASTM D4327)	3	Percentage of water-soluble sulfate as (SO ₄) in soil samples. Used as an indication of the relative degree of sulfate attack on concrete and for selecting the cement type.
Chloride Content (ASTM D4327)	3	Percentage of soluble chloride in soil. Used to evaluate the potential attack on encased reinforcing steel.
Resistivity (ASTM D1125)	3	The potential of the soil to corrode metal.
pH (ASTM D4972)	3	The acidity or alkalinity of subgrade material

UNIFIED SOIL CLASSIFICATION

<i>COBBLES</i>	<i>GRAVEL</i>		<i>SAND</i>			<i>SILT OR CLAY</i>
	COARSE	FINE	COARSE	MEDIUM	FINE	
U.S. SIEVE SIZE IN INCHES			U.S. STANDARD SIEVE No.			HYDROMETER

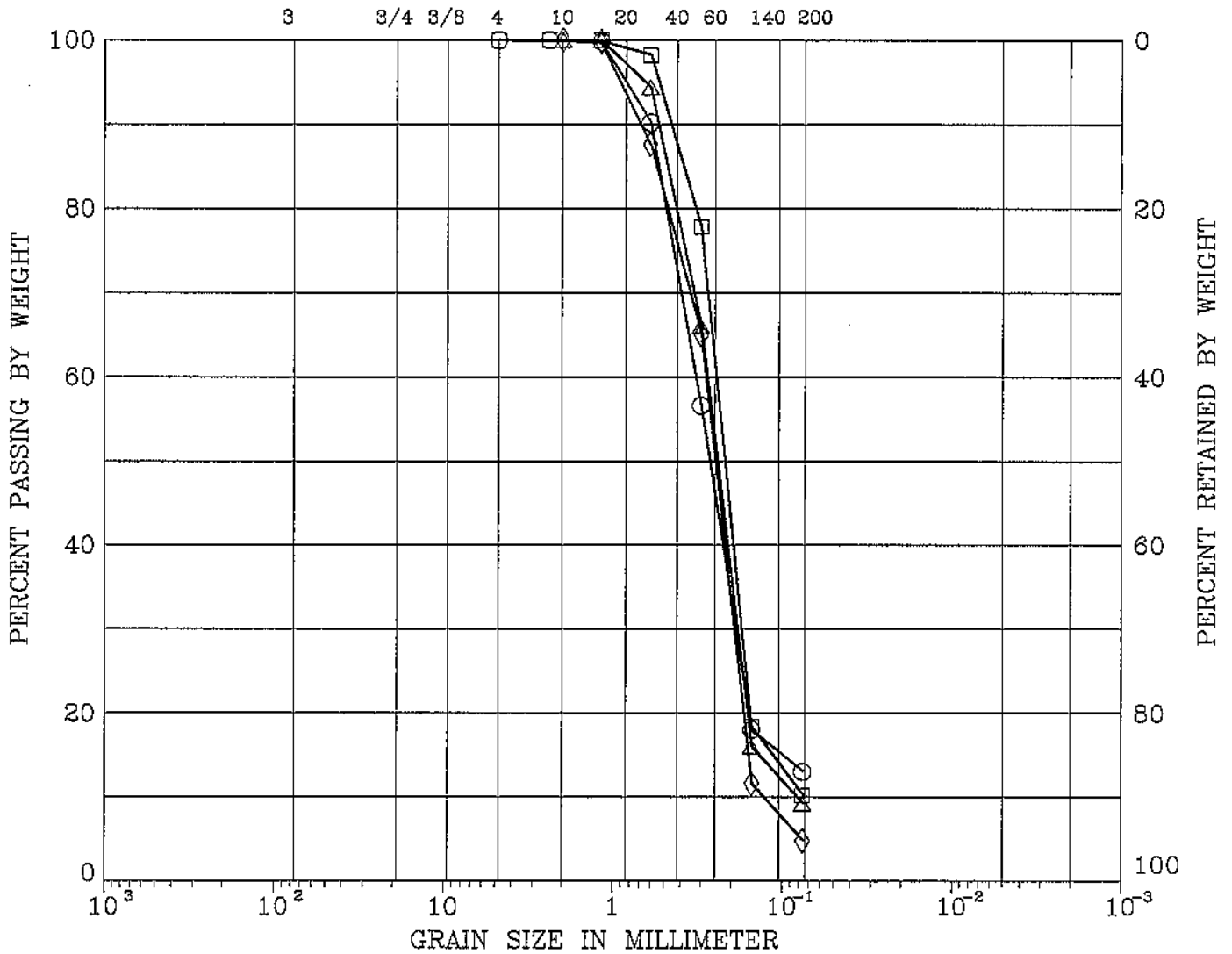

<u>SYMBOL</u>	<u>BORING</u>	<u>DEPTH (ft)</u>	<u>LL (%)</u>	<u>PI (%)</u>	<u>DESCRIPTION</u>
○	B-38	0-1.5			SILTY SAND (SM)
□	B-46	3.5-5			POORLY-GRADED SAND with Silt (SP-SM)
△	B-47	5-6.5			POORLY-GRADED SAND with Silt (SP-SM)
◇	B-55	15-16.5			POORLY-GRADED SAND (SP)

Remark :

B82604.01	Fitch Park
The Twining Labs Inc. Fresno, CA	GRAIN SIZE DISTRIBUTION Figure No. 1

UNIFIED SOIL CLASSIFICATION

COBBLES	GRAVEL		SAND			SILT OR CLAY
	COARSE	FINE	COARSE	MEDIUM	FINE	
U.S. SIEVE SIZE IN INCHES			U.S. STANDARD SIEVE No.			HYDROMETER

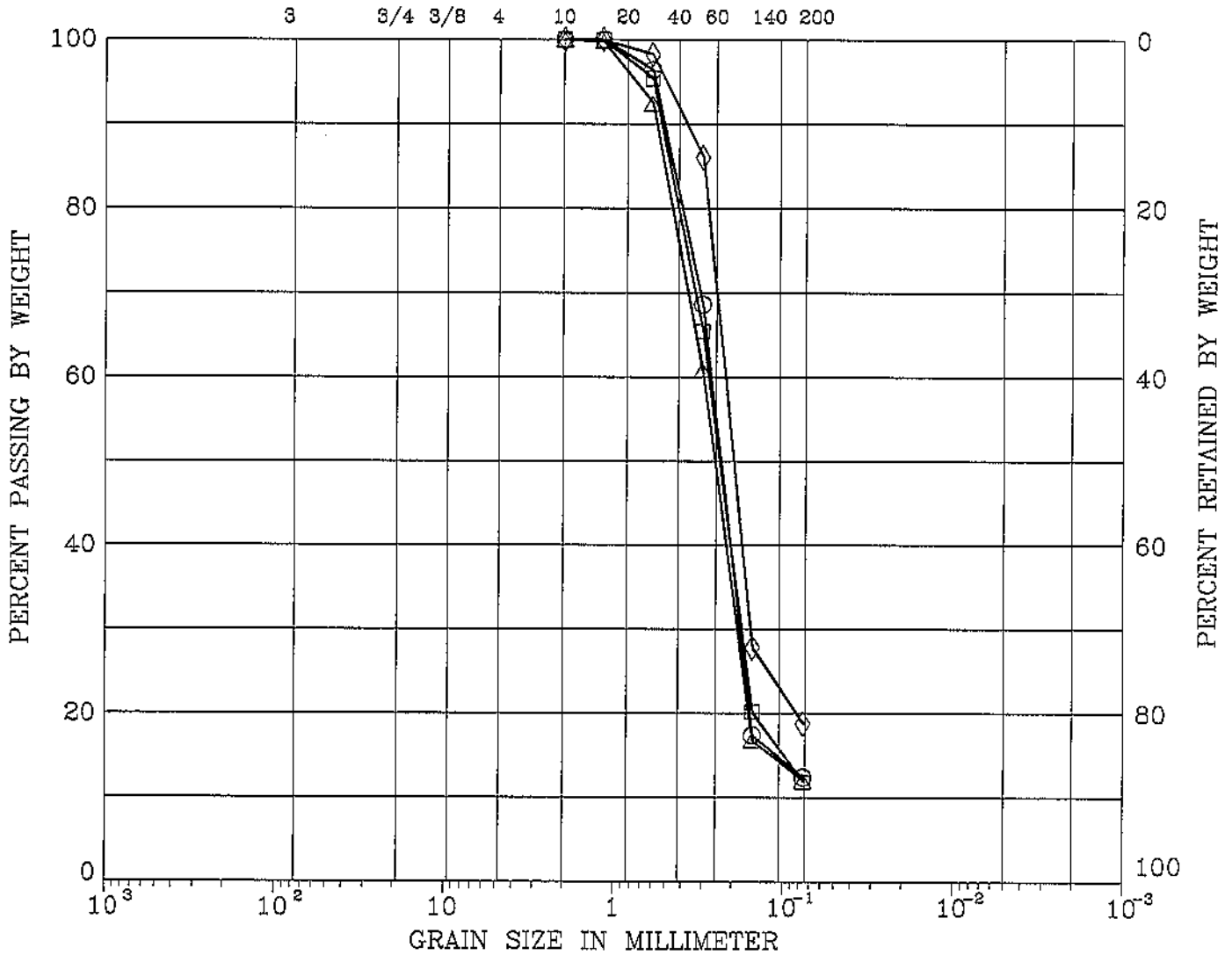

SYMBOL	BORING	DEPTH (ft)	LL (%)	PI (%)	DESCRIPTION
○	B-4	3.5-5			SILTY SAND (SM)
□	B-19	1.5-3			Poorly Graded Sand with Silt (SP-SM)
△	B-30	3.5-5			SILTY SAND (SM)
◇	B-37	2.5-4			SILTY SAND (SM)

Remark :

B82604.01	Fitch Park
The Twining Labs Inc. Fresno, CA	GRAIN SIZE DISTRIBUTION Figure No. 2

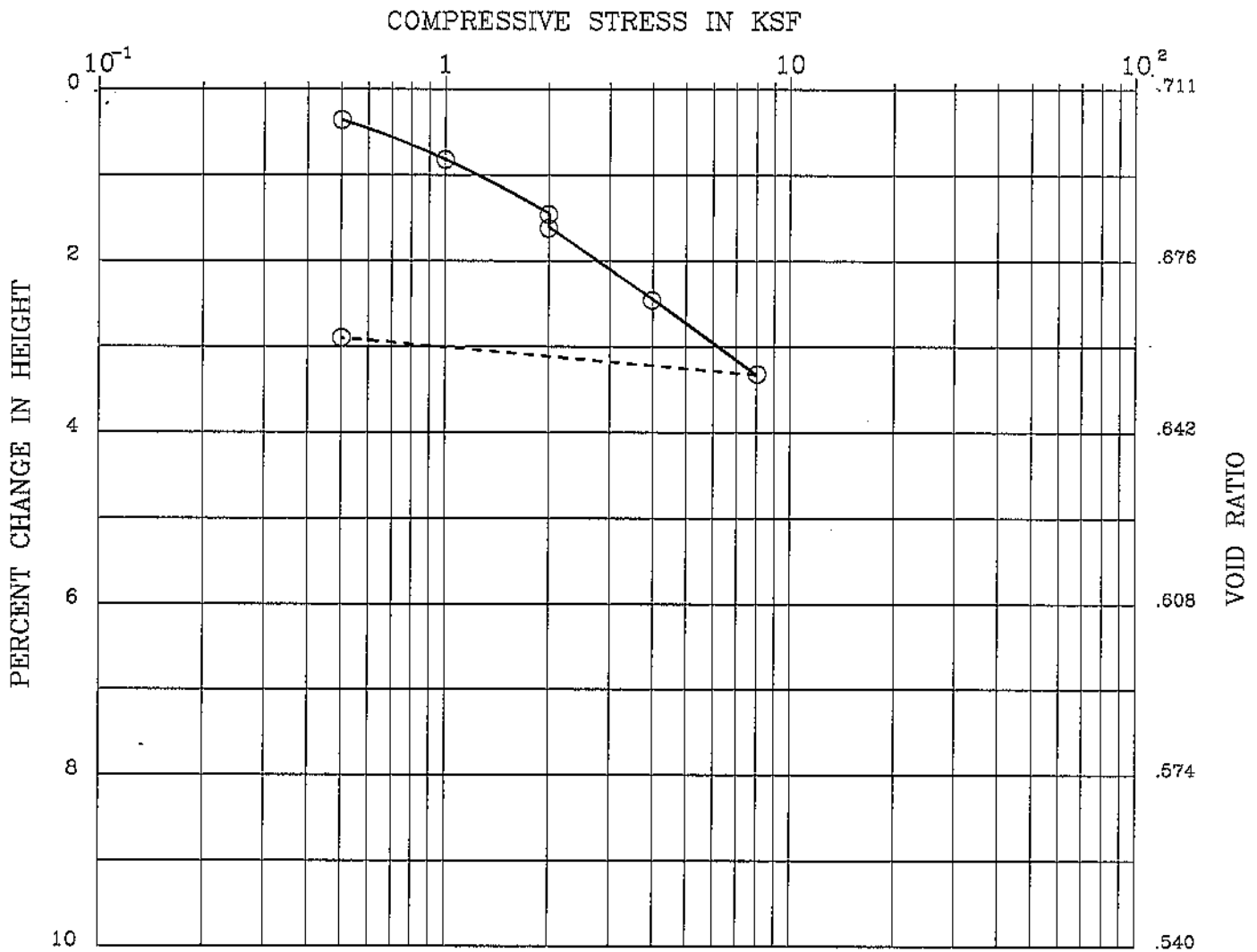

BORING : B-17
 DEPTH (ft) : 1.5-3
 SPEC. GRAVITY : 2.65

DESCRIPTION : Silty SAND (SM)
 LIQUID LIMIT :
 PLASTIC LIMIT :

	MOISTURE CONTENT (%)	DRY DENSITY (pcf)	PERCENT SATURATION	VOID RATIO
INITIAL	12.0	96.8	45	.711
FINAL	17.6	99.7	71	.661

Remark : Saturated at 2ksf

B82604.01	Fitch Park
The Twining Labs Inc. Fresno, CA	CONSOLIDATION TEST Figure No. 5

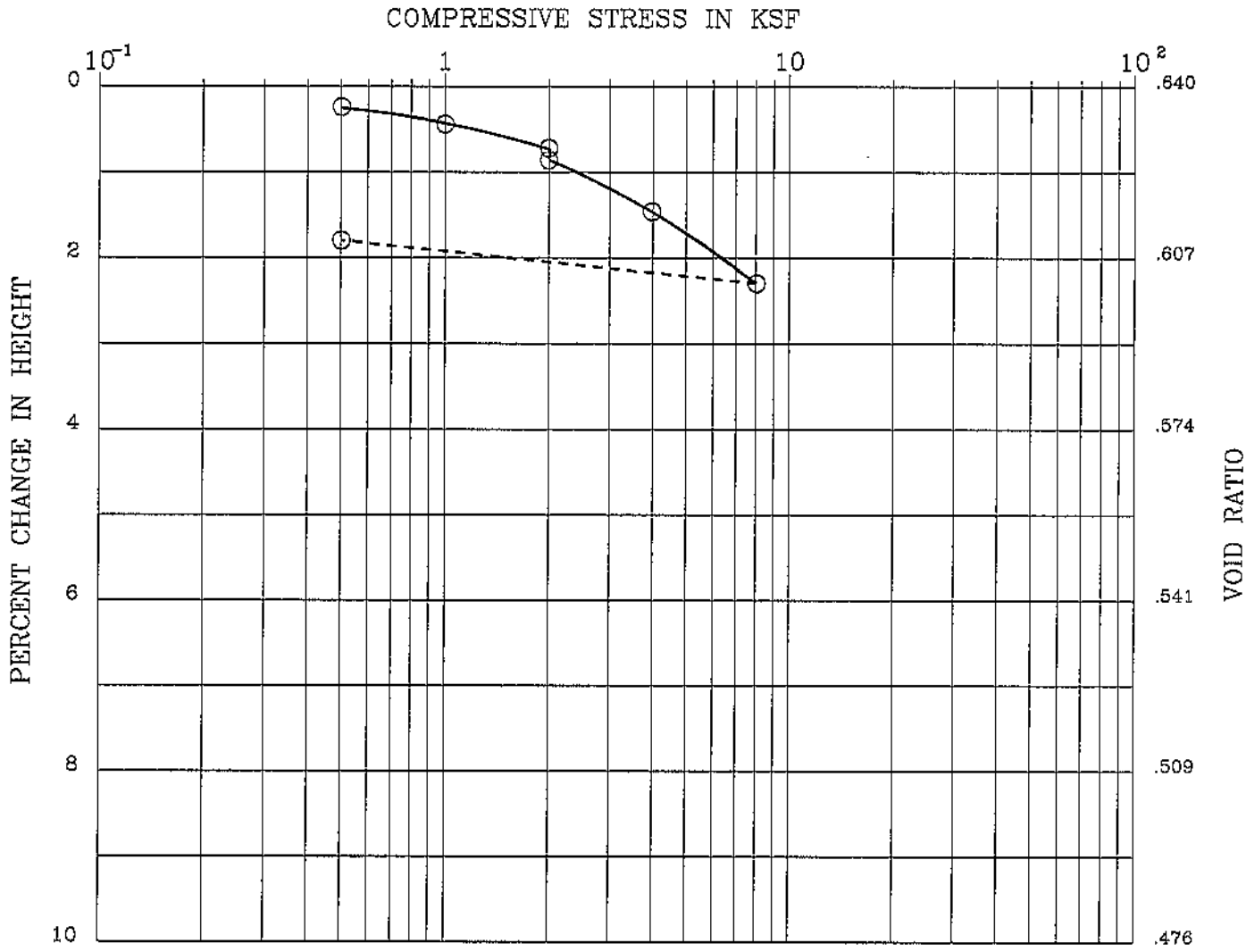

BORING : B-28 DESCRIPTION : Silty SAND (SM)
 DEPTH (ft) : 5-6.5 LIQUID LIMIT :
 SPEC. GRAVITY : 2.65 PLASTIC LIMIT :

	<u>MOISTURE CONTENT (%)</u>	<u>DRY DENSITY (pcf)</u>	<u>PERCENT SATURATION</u>	<u>VOID RATIO</u>
INITIAL	11.8	101.0	49	.640
FINAL	17.8	102.8	77	.610

Remark : Saturated at 2ksf

B82604.01	Fitch Park
The Twining Labs Inc. Fresno, CA	CONSOLIDATION TEST Figure No. 7

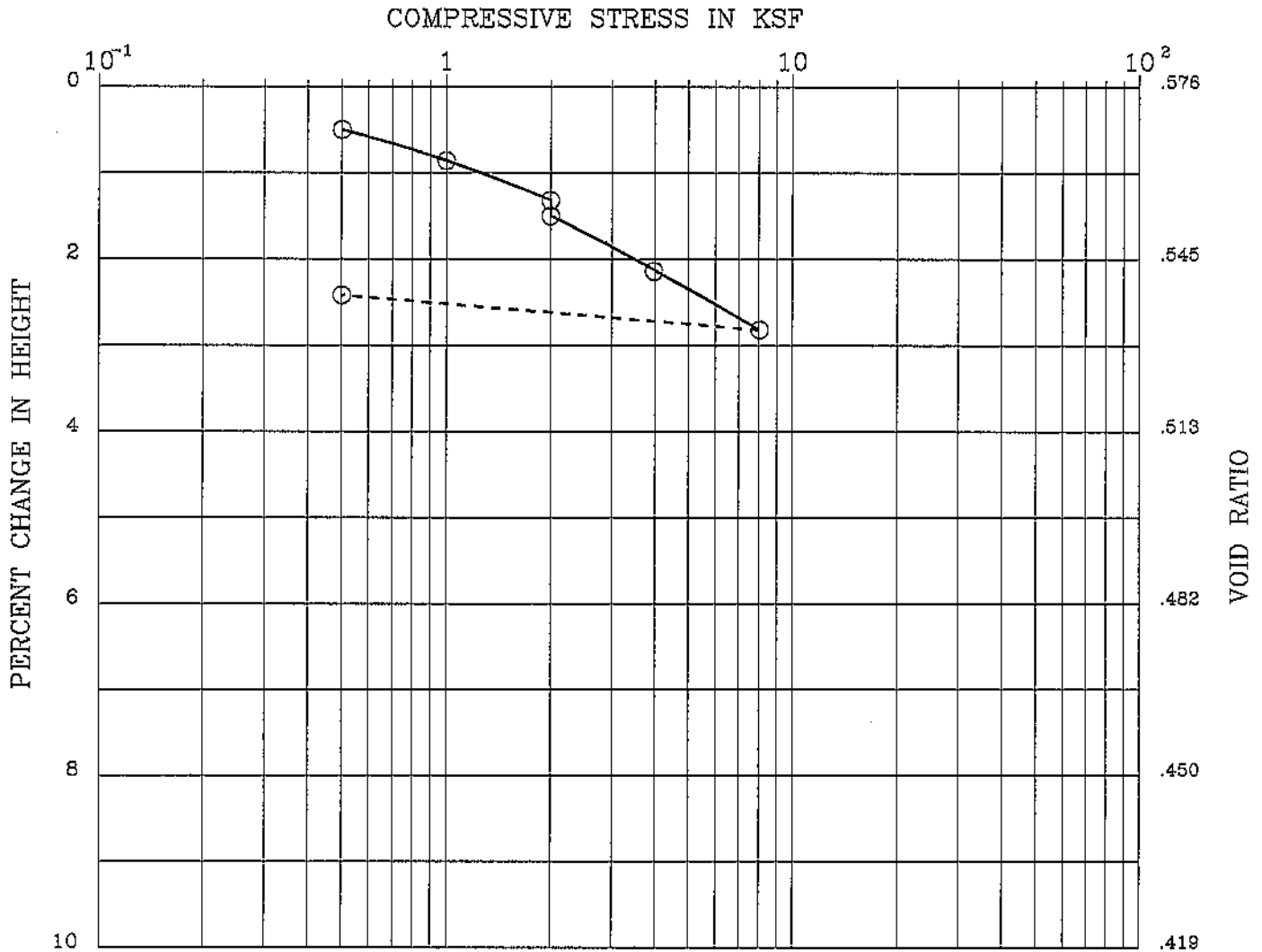

BORING : B-40 DESCRIPTION : Silty SAND (SM)
 DEPTH (ft) : 0-1.5 LIQUID LIMIT :
 SPEC. GRAVITY : 2.65 PLASTIC LIMIT :

	<u>MOISTURE CONTENT (%)</u>	<u>DRY DENSITY (pcf)</u>	<u>PERCENT SATURATION</u>	<u>VOID RATIO</u>
INITIAL	8.3	105.0	38	.576
FINAL	16.4	107.7	81	.537

Remark : Saturated at 2ksf

B82604.01

Fitch Park

The Twining
Labs Inc.
Fresno, CA

CONSOLIDATION TEST

Figure No. 9

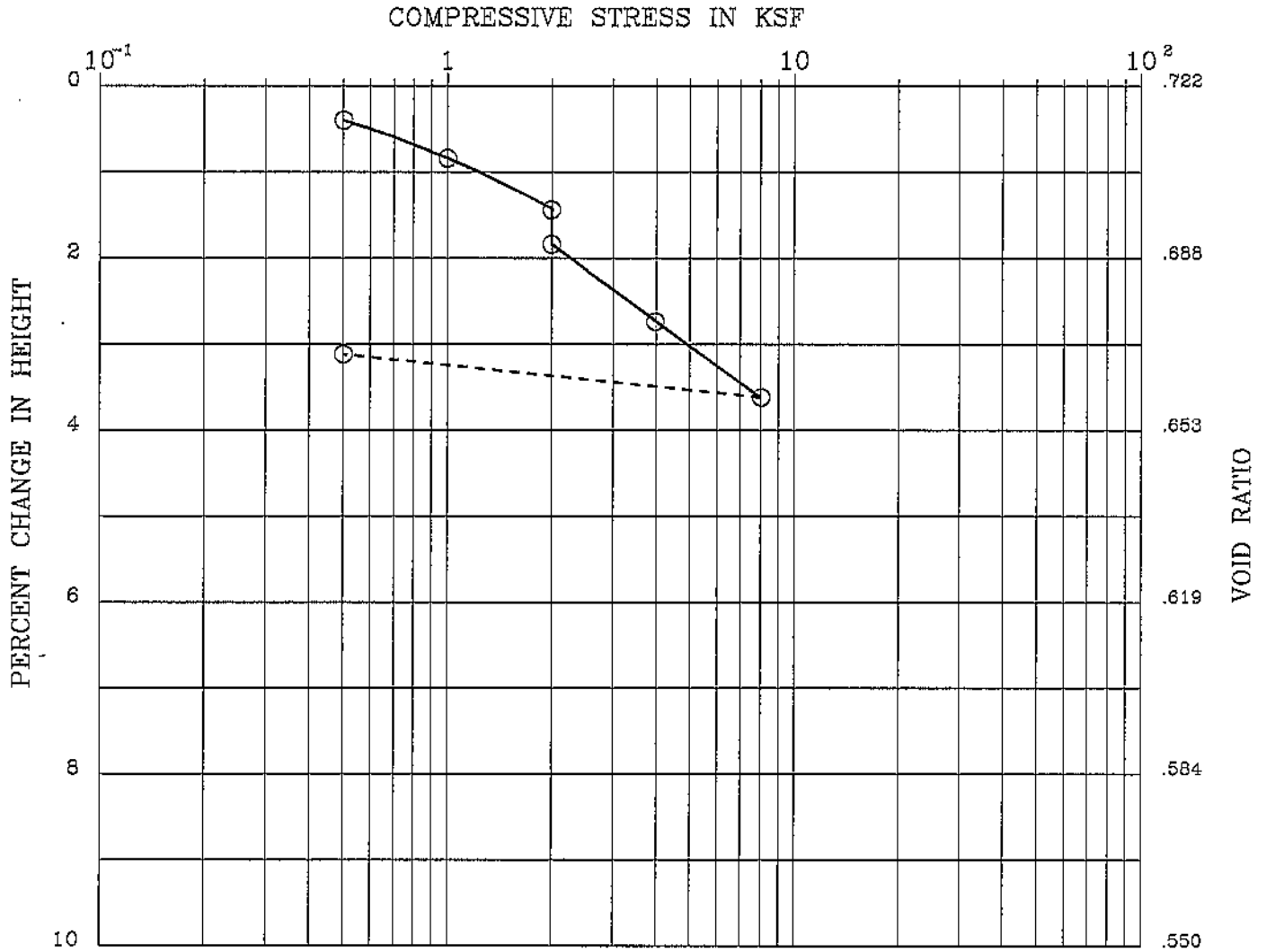

BORING	: B-42	DESCRIPTION	: Poorly Graded SAND (SP)
DEPTH (ft)	: 5-6.5	LIQUID LIMIT	:
SPEC. GRAVITY	: 2.65	PLASTIC LIMIT	:

	MOISTURE CONTENT (%)	DRY DENSITY (pcf)	PERCENT SATURATION	VOID RATIO
INITIAL	6.9	96.1	25	.722
FINAL	21.4	99.3	85	.667

Remark : Saturated at 2ksf

B82604.01	Fitch Park
The Twining Labs Inc. Fresno, CA	CONSOLIDATION TEST
	Figure No. 10

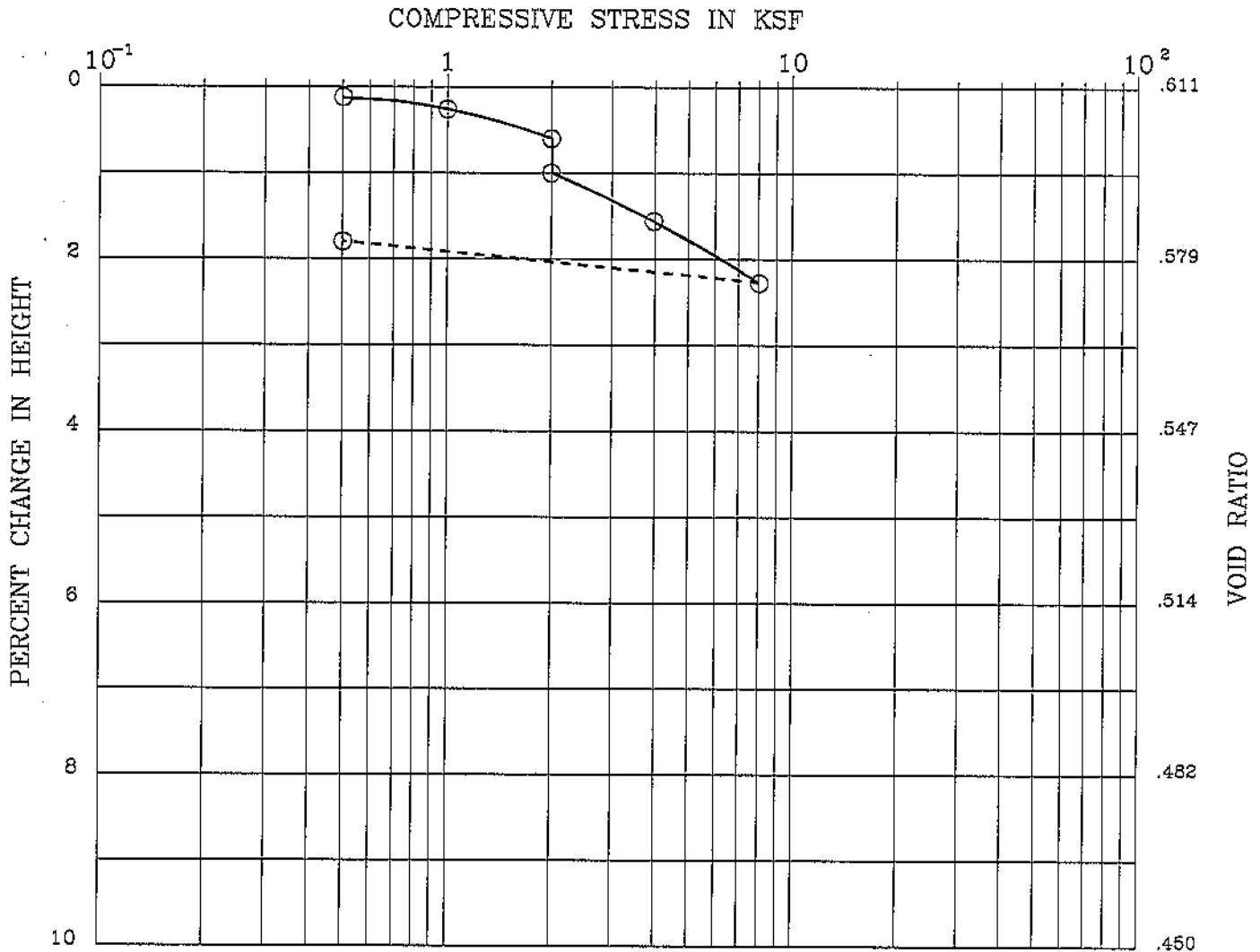

BORING : B-44 DESCRIPTION : Silty SAND (SM)
 DEPTH (ft) : 3.5-4.5 LIQUID LIMIT :
 SPEC. GRAVITY : 2.65 PLASTIC LIMIT :

	MOISTURE CONTENT (%)	DRY DENSITY (pcf)	PERCENT SATURATION	VOID RATIO
INITIAL	8.2	102.8	36	.611
FINAL	19.3	104.6	88	.582

Remark : Saturated at 2ksf

B82604.01	Fitch Park
The Twining Labs Inc. Fresno, CA	CONSOLIDATION TEST Figure No. 11

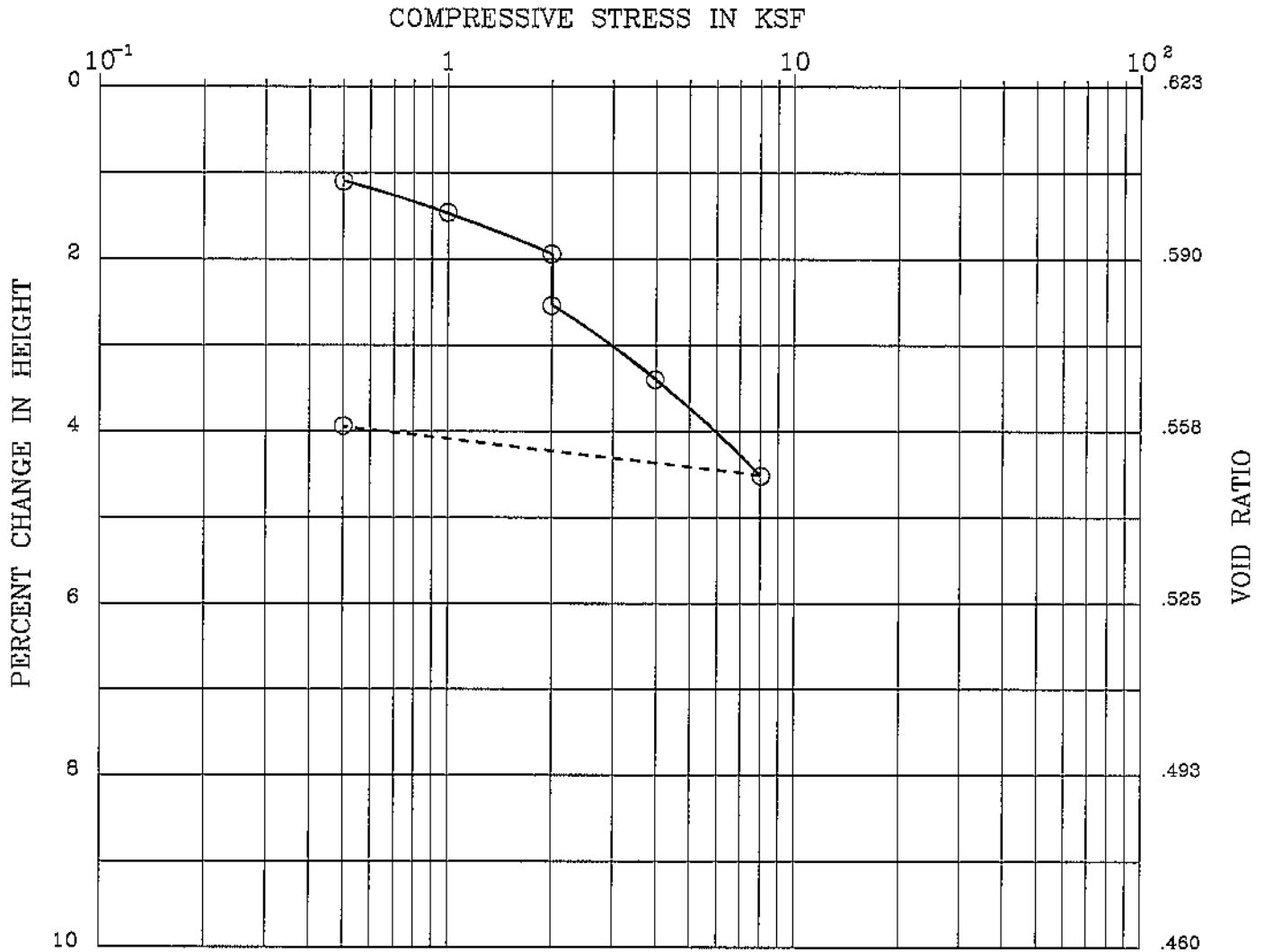

BORING : B-55 DESCRIPTION : Silty SAND (SM)
 DEPTH (ft) : 3.5-5 LIQUID LIMIT :
 SPEC. GRAVITY : 2.65 PLASTIC LIMIT :

	<u>MOISTURE CONTENT (%)</u>	<u>DRY DENSITY (pcf)</u>	<u>PERCENT SATURATION</u>	<u>VOID RATIO</u>
INITIAL	9.7	102.0	41	.623
FINAL	19.2	106.3	91	.558

Remark : Saturated at 2ksf

B82604.01	Fitch Park
The Twining Labs Inc. Fresno, CA	CONSOLIDATION TEST Figure No. 13

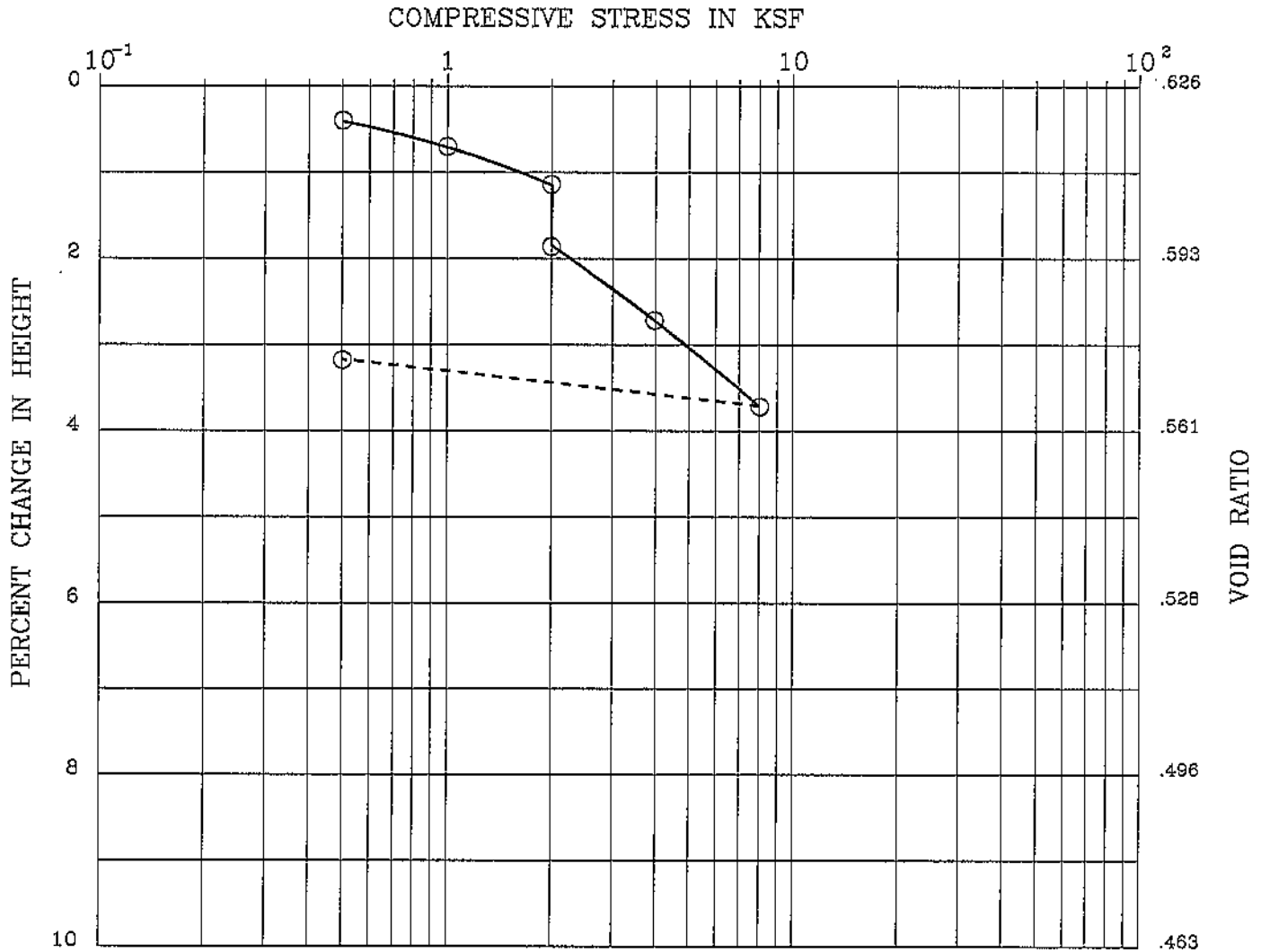

BORING : B-56 DESCRIPTION : Silty SAND (SM)
 DEPTH (ft) : 1.5-3 LIQUID LIMIT :
 SPEC. GRAVITY : 2.65 PLASTIC LIMIT :

	<u>MOISTURE CONTENT (%)</u>	<u>DRY DENSITY (pcf)</u>	<u>PERCENT SATURATION</u>	<u>VOID RATIO</u>
INITIAL	8.5	101.8	36	.626
FINAL	19.5	105.2	90	.574

Remark : Saturated at 2ksf

B82604.01	Fitch Park
The Twining Labs Inc. Fresno, CA	CONSOLIDATION TEST Figure No. 14

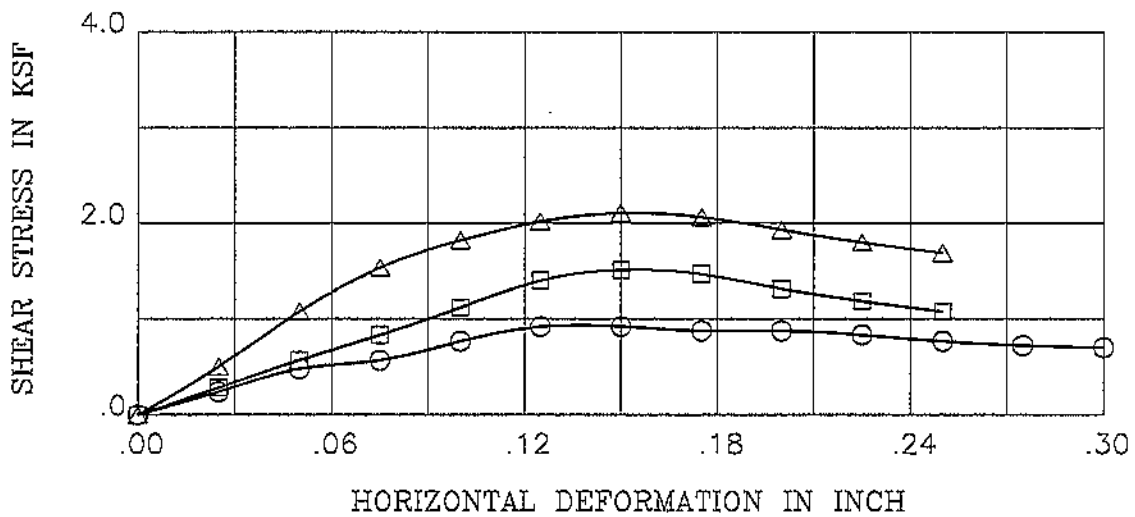
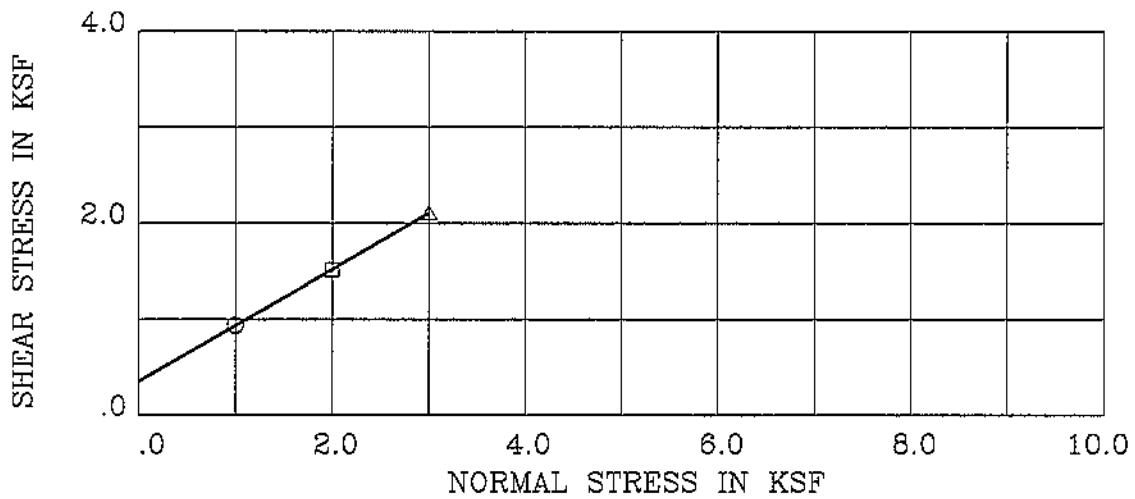

BORING/SAMPLE : B-2 DEPTH (ft) : .8-2.3
 DESCRIPTION : Silty SAND (SM)
 STRENGTH INTERCEPT (C) : .349 KSF
 FRICTION ANGLE (PHI) : 30.4 DEG (PEAK STRENGTH)

SYMBOL	MOISTURE CONTENT (%)	DRY DENSITY (pcf)	VOID RATIO	NORMAL STRESS (ksf)	PEAK SHEAR (ksf)	RESIDUAL SHEAR (ksf)
○	18.1	106.8	.549	1.00	.94	.70
□	16.5	109.9	.505	2.00	1.52	1.08
△	18.0	105.8	.562	3.00	2.11	1.69

Remark :

B82604.01

Fitch Park

The Twining
Labs Inc.
Fresno, CA

DIRECT SHEAR TEST

Figure No. 15

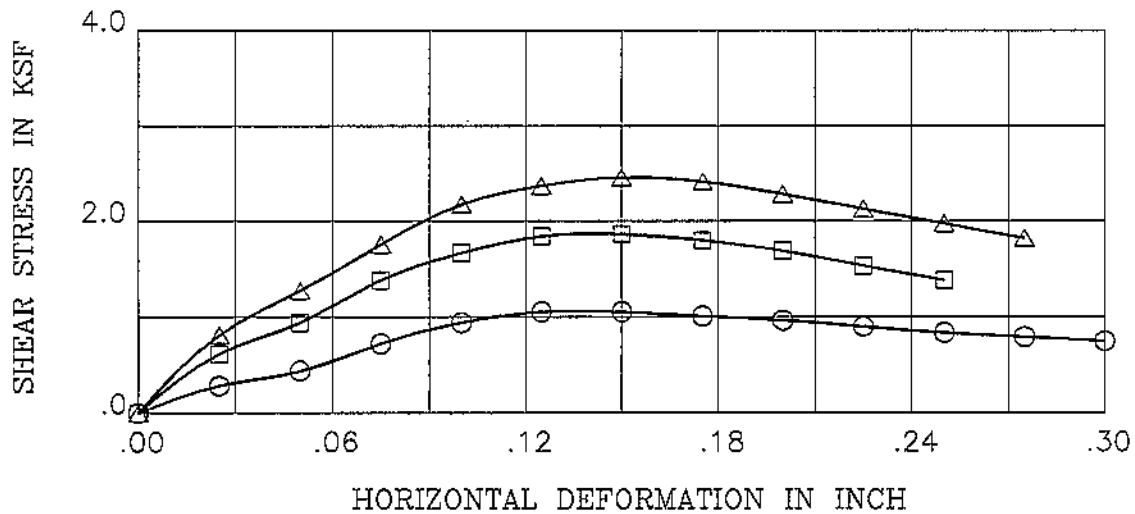
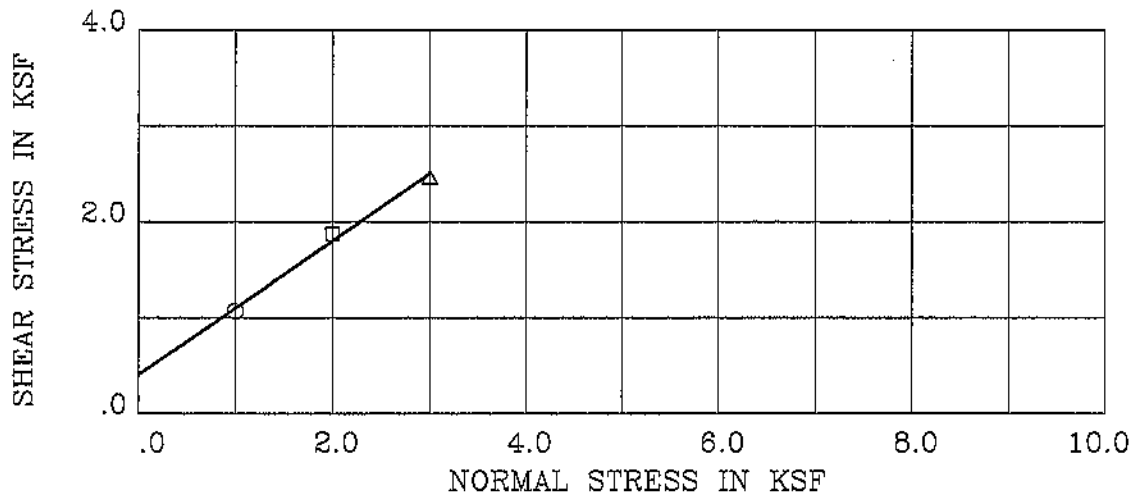

BORING/SAMPLE : B-17 DEPTH (ft) : 1.5-3
 DESCRIPTION : Silty SAND (SM)
 STRENGTH INTERCEPT (C) : .403 KSF
 FRICTION ANGLE (PHI) : 34.9 DEG (PEAK STRENGTH)

SYMBOL	MOISTURE CONTENT (%)	DRY DENSITY (pcf)	VOID RATIO	NORMAL STRESS (ksf)	PEAK SHEAR (ksf)	RESIDUAL SHEAR (ksf)
○	25.8	96.2	.719	1.00	1.06	.75
□	24.7	96.6	.713	2.00	1.87	1.38
△	25.6	98.0	.687	3.00	2.46	1.82

Remark :

B82604.01	Fitch Park
The Twining Labs Inc. Fresno, CA	DIRECT SHEAR TEST Figure No. 16

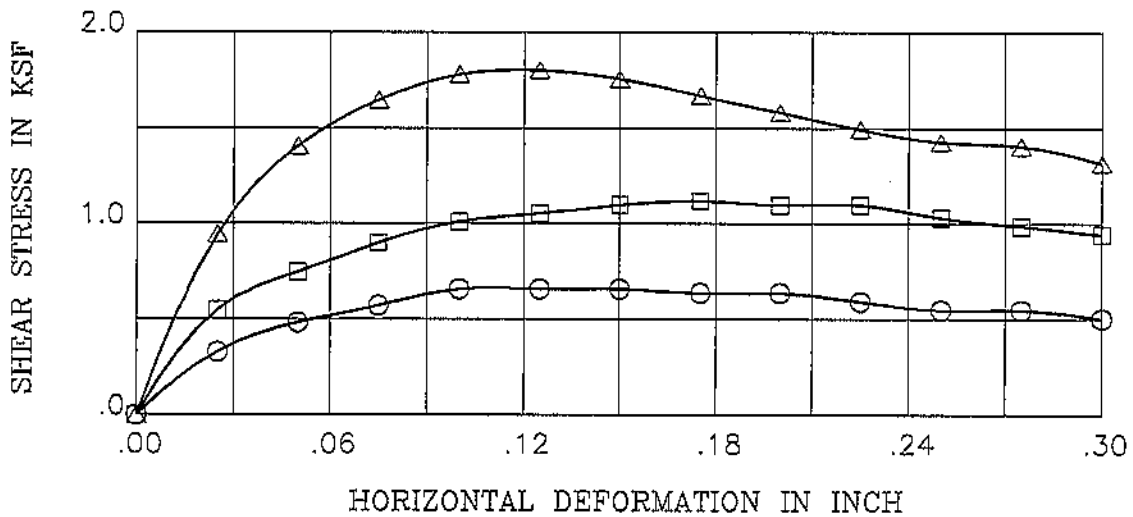
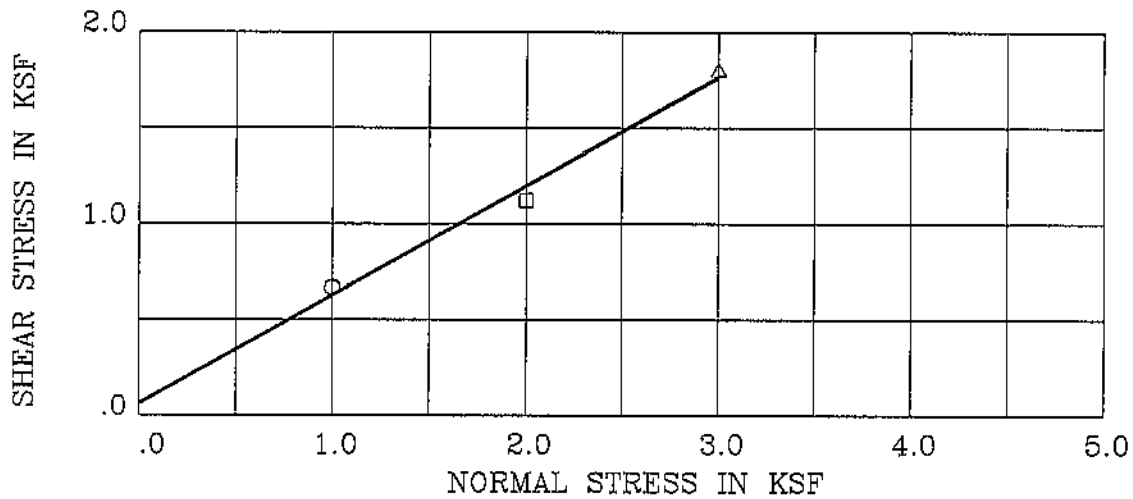

BORING/SAMPLE : B-25 DEPTH (ft) : 1.5-3
 DESCRIPTION : Silty SAND (SM)
 STRENGTH INTERCEPT (C) : .058 KSF
 FRICTION ANGLE (PHI) : 29.6 DEG (PEAK STRENGTH)

SYMBOL	MOISTURE CONTENT (%)	DRY DENSITY (pcf)	VOID RATIO	NORMAL STRESS (ksf)	PEAK SHEAR (ksf)	RESIDUAL SHEAR (ksf)
○	26.4	93.8	.763	1.00	.67	.50
□	25.8	92.6	.786	2.00	1.12	.94
△	22.8	97.1	.702	3.00	1.80	1.32

Remark :

B82604.01	Fitch Park
The Twining Labs Inc. Fresno, CA	DIRECT SHEAR TEST Figure No. 17

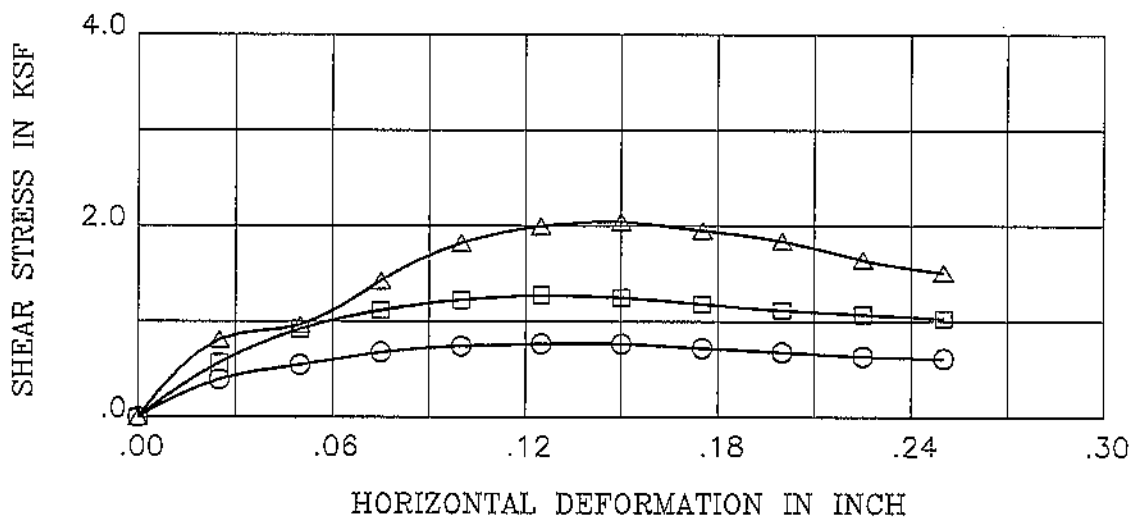
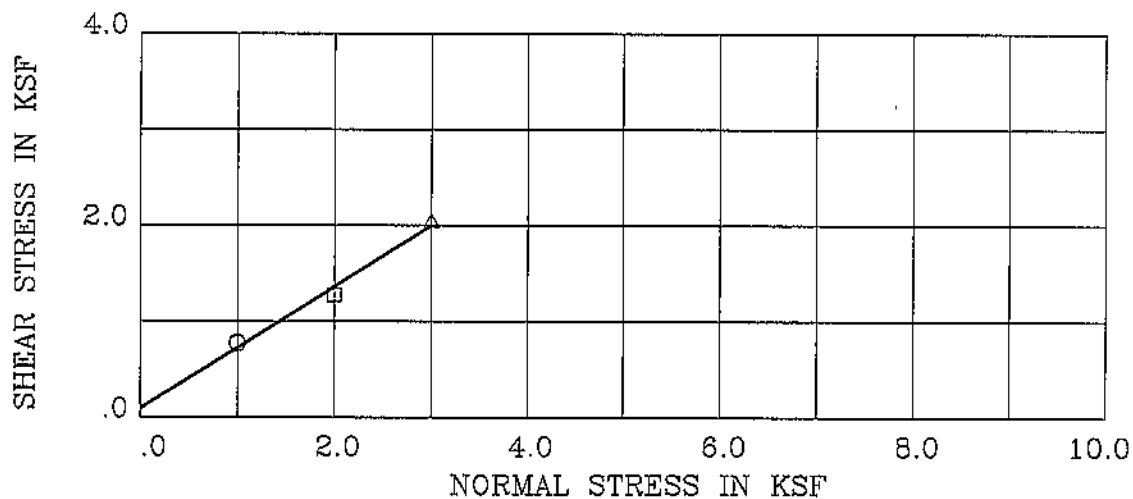

BORING/SAMPLE : B-41 DEPTH (ft) : 5.0-6.5
 DESCRIPTION : Silty SAND (SM)
 STRENGTH INTERCEPT (C) : .092 KSF
 FRICTION ANGLE (PHI) : 32.4 DEG (PEAK STRENGTH)

SYMBOL	MOISTURE CONTENT (%)	DRY DENSITY (pcf)	VOID RATIO	NORMAL STRESS (ksf)	PEAK SHEAR (ksf)	RESIDUAL SHEAR (ksf)
○	18.8	102.8	.608	1.00	.77	.61
□	23.6	94.1	.758	2.00	1.27	1.03
△	19.6	106.1	.559	3.00	2.04	1.51

Remark :

B82604.01

Fitch Park

The Twining
Labs Inc.
Fresno, CA

DIRECT SHEAR TEST Figure No. 18

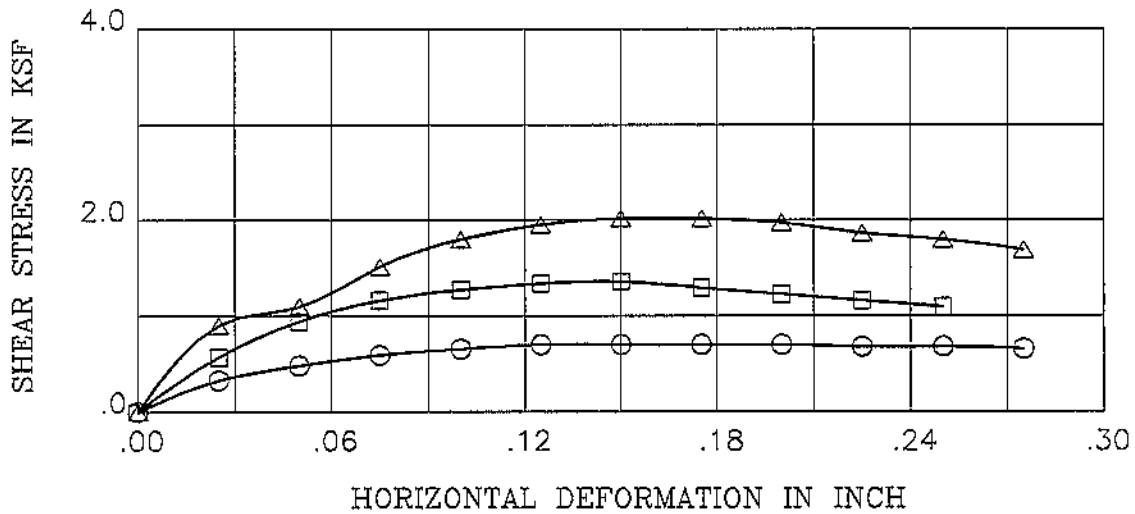
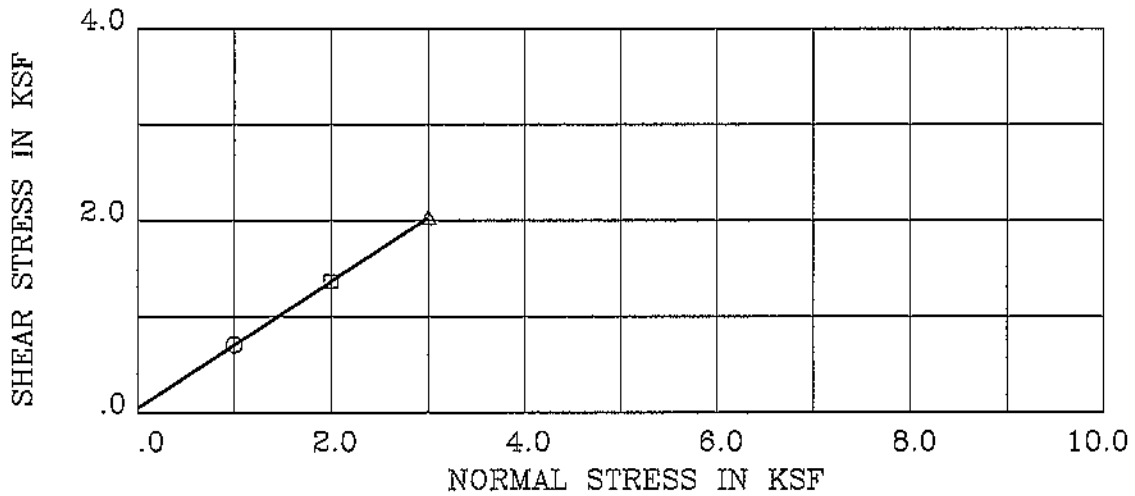

BORING/SAMPLE : B-49 DEPTH (ft) : 3.5-5
 DESCRIPTION : Silty SAND (SM)
 STRENGTH INTERCEPT (C) : .046 KSF
 FRICTION ANGLE (PHI) : 33.4 DEG (PEAK STRENGTH)

SYMBOL	MOISTURE CONTENT (%)	DRY DENSITY (pcf)	VOID RATIO	NORMAL STRESS (ksf)	PEAK SHEAR (ksf)	RESIDUAL SHEAR (ksf)
O	19.9	103.7	.595	1.00	.71	.66
□	18.6	107.8	.535	2.00	1.36	1.10
Δ	18.8	102.4	.614	3.00	2.03	1.69

Remark :

B82604.01	Fitch Park
The Twining Labs Inc. Fresno, CA	DIRECT SHEAR TEST Figure No. 19

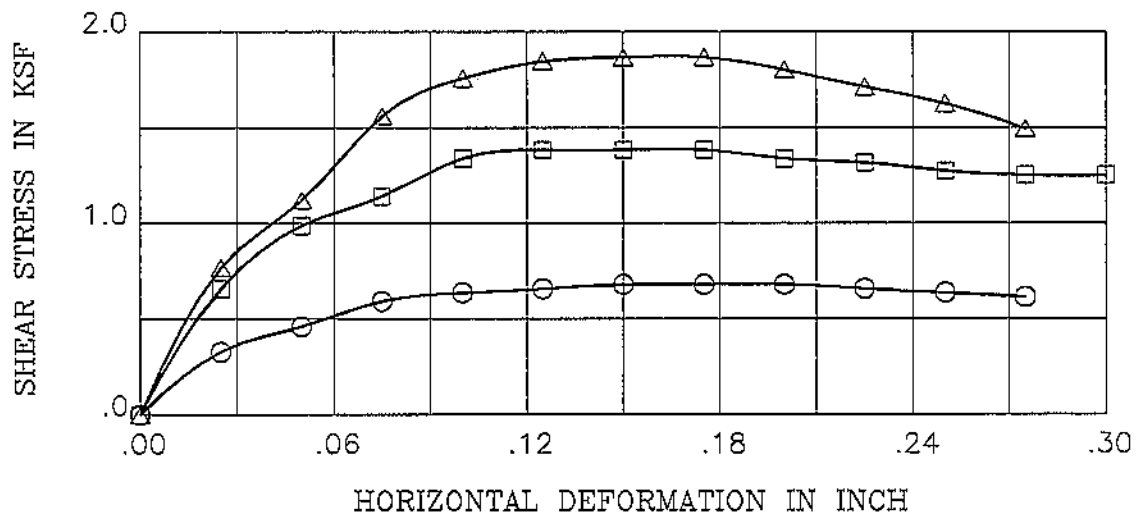
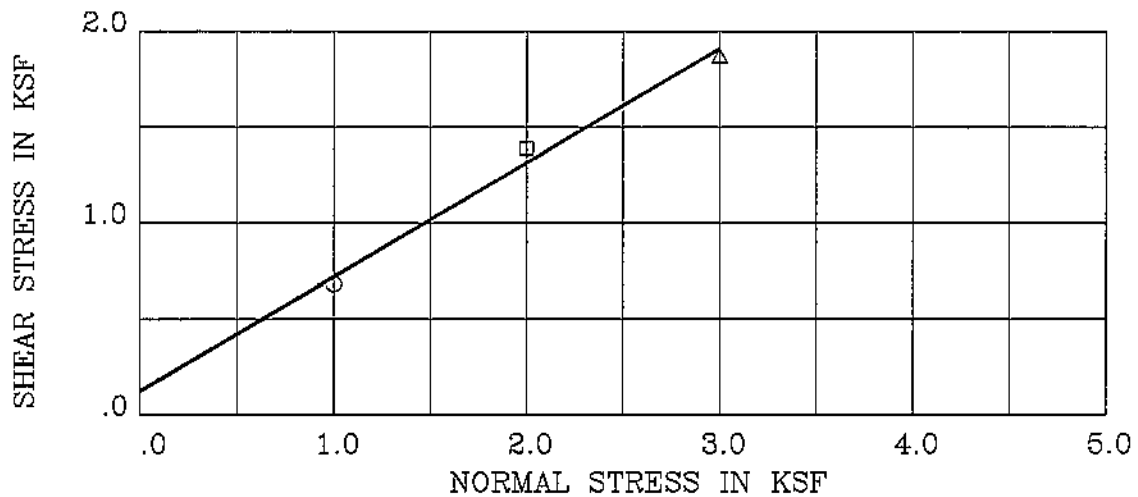

BORING/SAMPLE : B-57 DEPTH (ft) : 3.5-5
 DESCRIPTION : Silty SAND (SM)
 STRENGTH INTERCEPT (C) : .124 KSF
 FRICTION ANGLE (PHI) : 30.7 DEG (PEAK STRENGTH)

SYMBOL	MOISTURE CONTENT (%)	DRY DENSITY (pcf)	VOID RATIO	NORMAL STRESS (ksf)	PEAK SHEAR (ksf)	RESIDUAL SHEAR (ksf)
○	18.6	102.8	.609	1.00	.68	.61
□	18.7	101.9	.622	2.00	1.39	1.25
△	19.8	103.6	.597	3.00	1.87	1.49

Remark :

B82604.01	Fitch Park
The Twining Labs Inc. Fresno, CA	DIRECT SHEAR TEST Figure No. 20

PROCTOR TEST REPORT

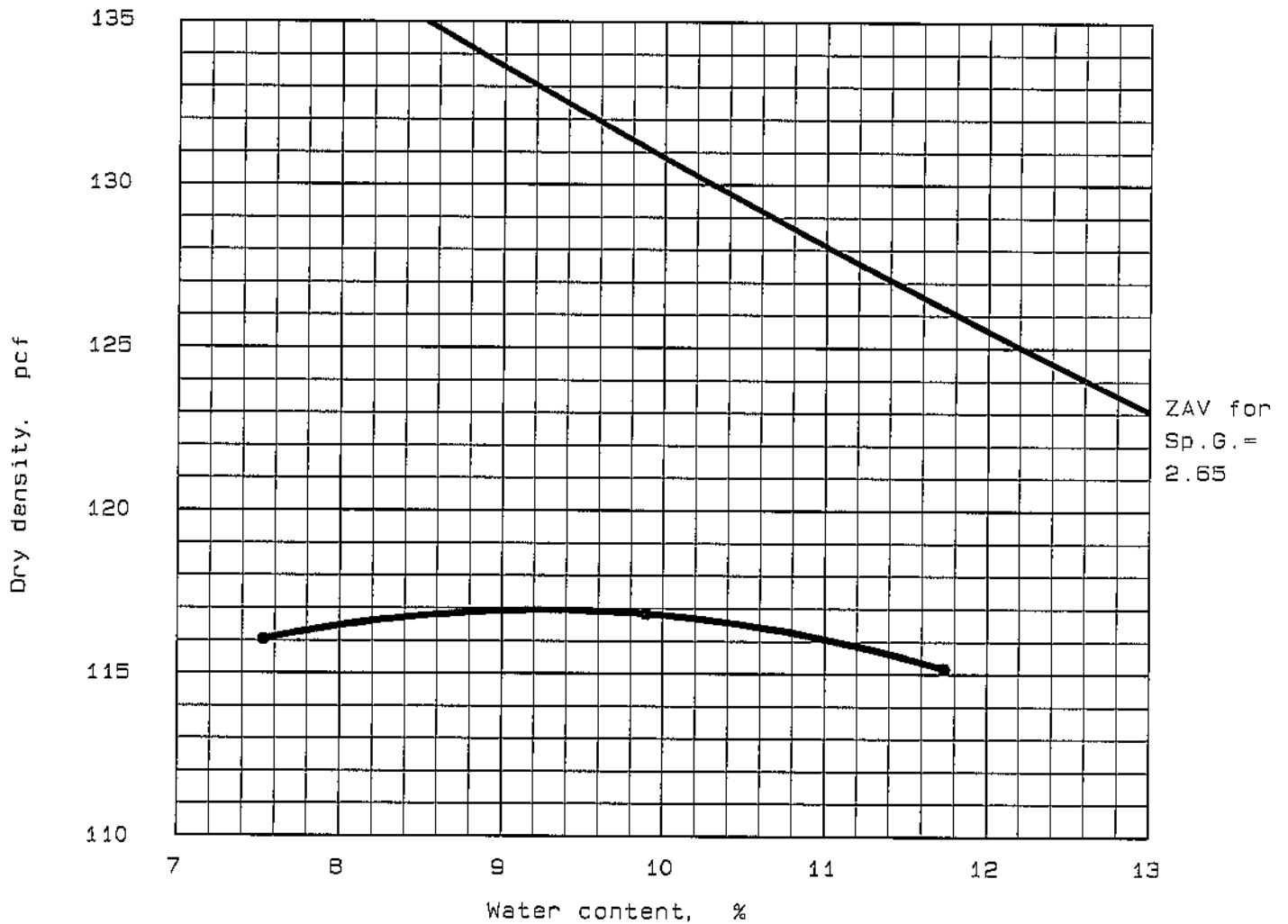

"Modified" Proctor, ASTM D 1557, Method A

Elev/ Depth	Classification		Nat. Moist.	Sp.G.	LL	PI	% > No. 4	% < No. 200
	USCS	AASHTO						
1-3.5	(SM)			2.65				

TEST RESULTS	MATERIAL DESCRIPTION
Optimum moisture = 9.3 % Maximum dry density = 117.0 pcf	SILTY, SAND (SM)
Project No.: B82604.01 Project: Fitch Park Location: R-1, B-2 Date: 03-29-04	Remarks:

PROCTOR TEST REPORT
THE TWINING LABORATORIES, INC.

Figure No. 21

PROCTOR TEST REPORT

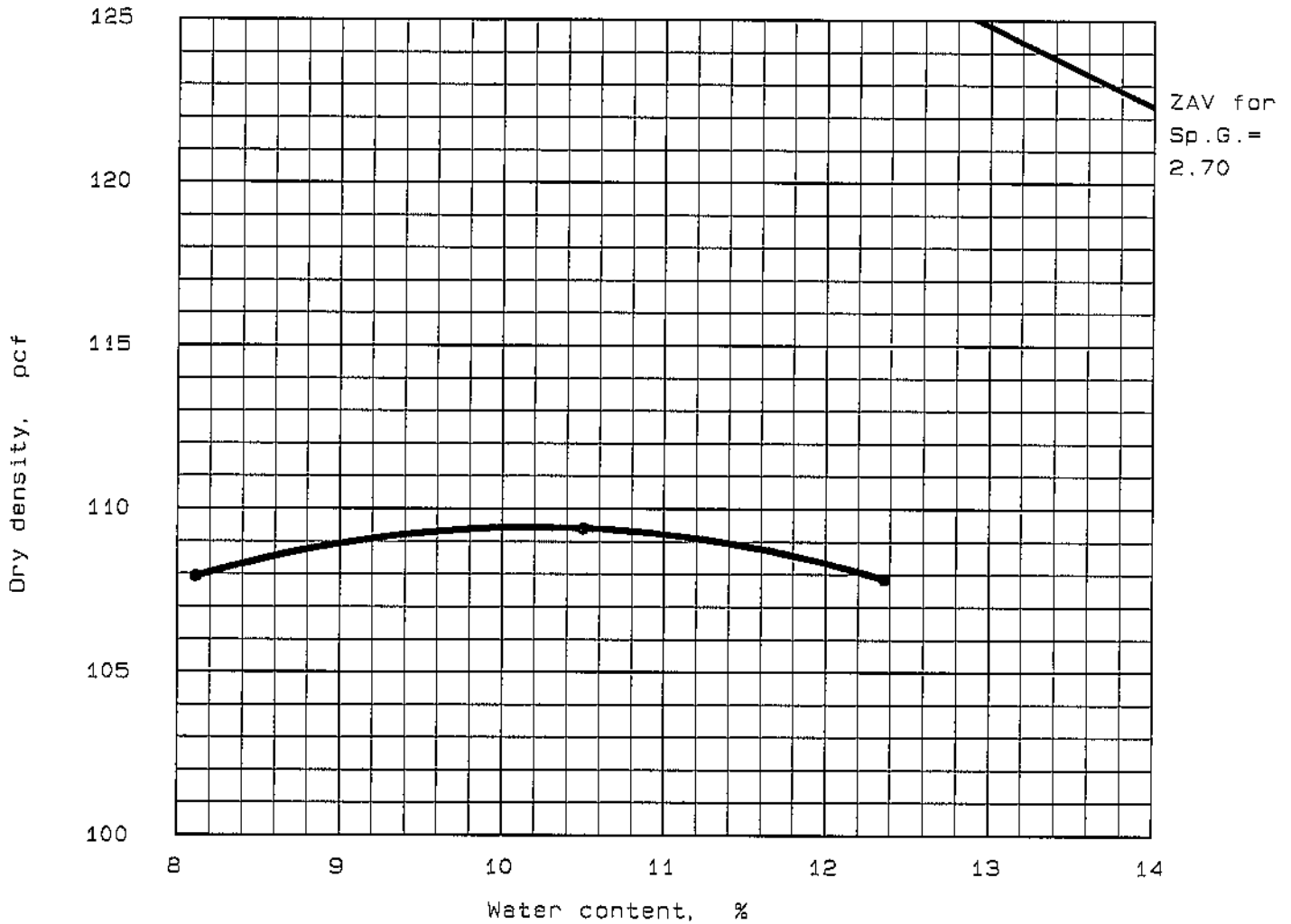

"Modified" Proctor, ASTM D 1557, Method A

Elev/ Depth	Classification		Nat. Moist.	Sp.G.	LL	PI	% > No. 4	% < No. 200
	USCS	AASHTO						
.5-3.5	SP-SM			2.70				

TEST RESULTS	MATERIAL DESCRIPTION
Optimum moisture = 10.2 % Maximum dry density = 109.4 pcf	Silty SAND (SM)

Project No.: BB2604.01
 Project: Fitch Park
 Location: R-14, B-19
 Date: 3-29-04

Remarks:

PROCTOR TEST REPORT

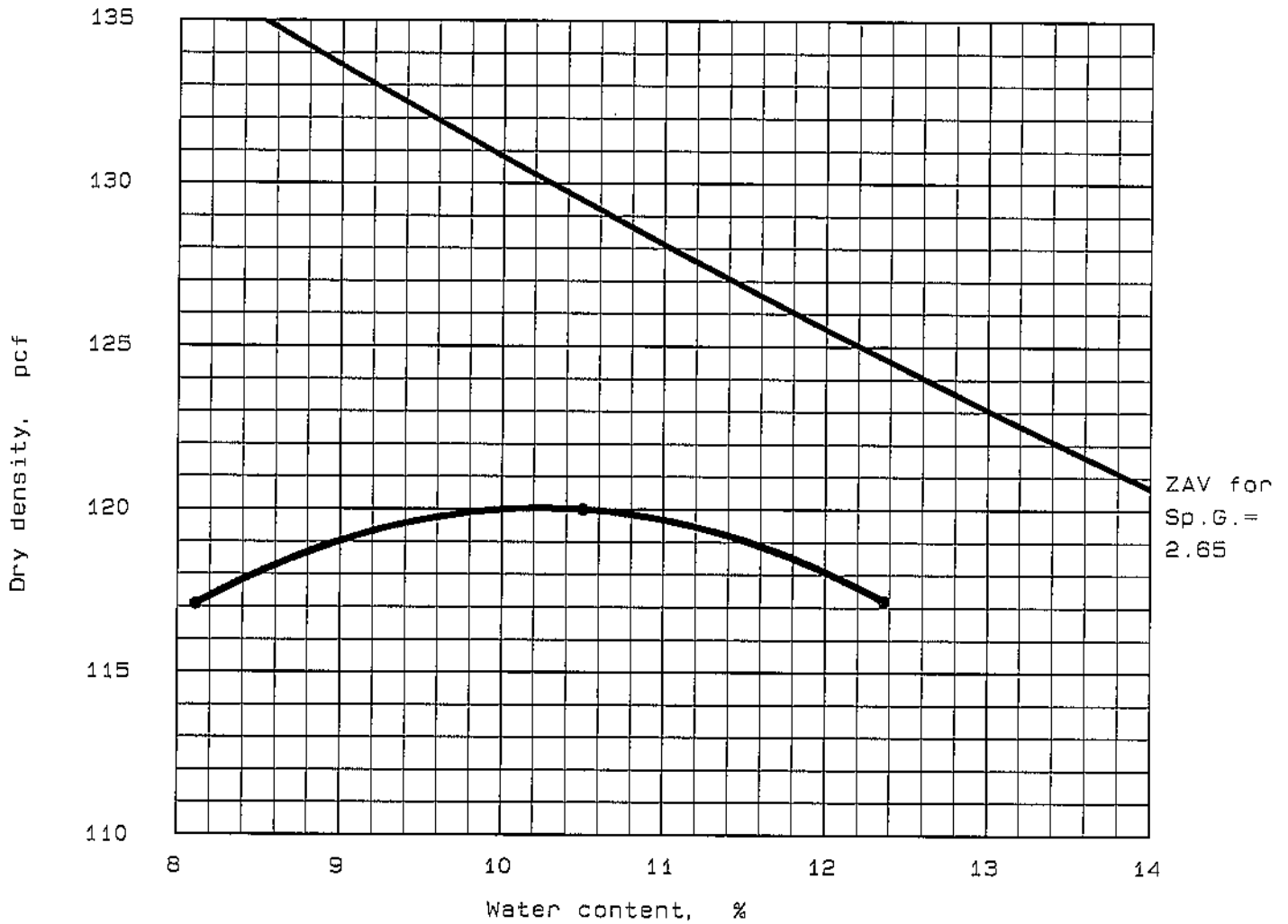

"Modified" Proctor, ASTM D 1557, Method A

Elev/ Depth	Classification		Nat. Moist.	Sp.G.	LL	PI	% > No. 4	% < No. 200
	USCS	AASHTO						
.5-3.5	(SM)			2.65				

TEST RESULTS	MATERIAL DESCRIPTION
Optimum moisture = 10.3 % Maximum dry density = 120.0 pcf	SILTY SAND (SM)
Project No.: B82604.01 Project: Fitch Park Location: A-28, B-38 Date: 03-26-04	Remarks:

PROCTOR TEST REPORT
THE TWINING LABORATORIES, INC.

Figure No. 23

PROCTOR TEST REPORT

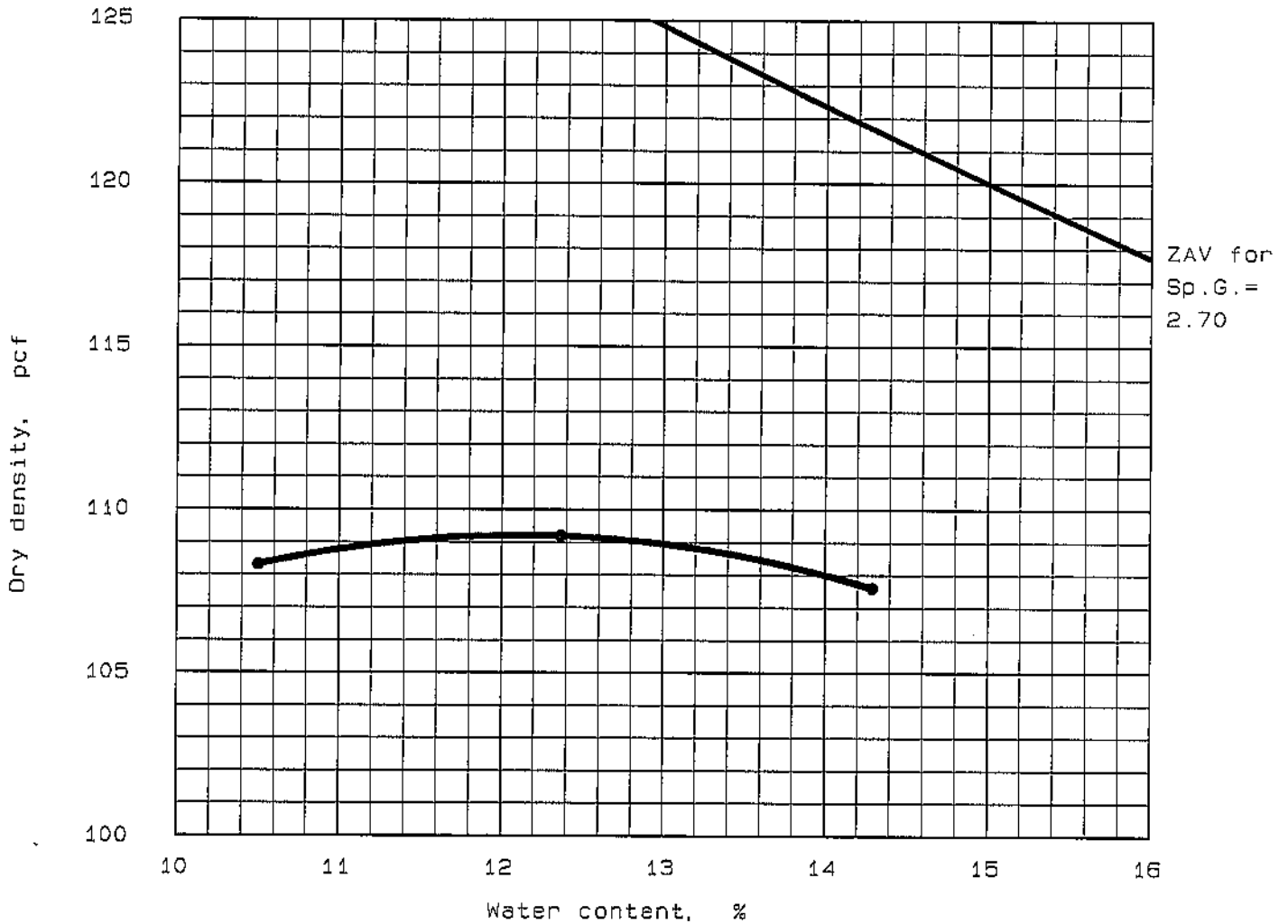

"Modified" Proctor, ASTM D 1557, Method A

Elev/ Depth	Classification		Nat. Moist.	Sp.G.	LL	PI	% > No. 4	% < No. 200
	USCS	AASHTO						
1-3.5	SM			2.70				

TEST RESULTS	MATERIAL DESCRIPTION
Optimum moisture = 12.1 % Maximum dry density = 109.2 pcf	Silty SAND (SM)
Project No.: BB2804.01 Project: Fitch Park Location: R-35, B-47 Date: 3-29-04	Remarks:

PROCTOR TEST REPORT
THE TWINING LABORATORIES, INC.

Figure No. 24

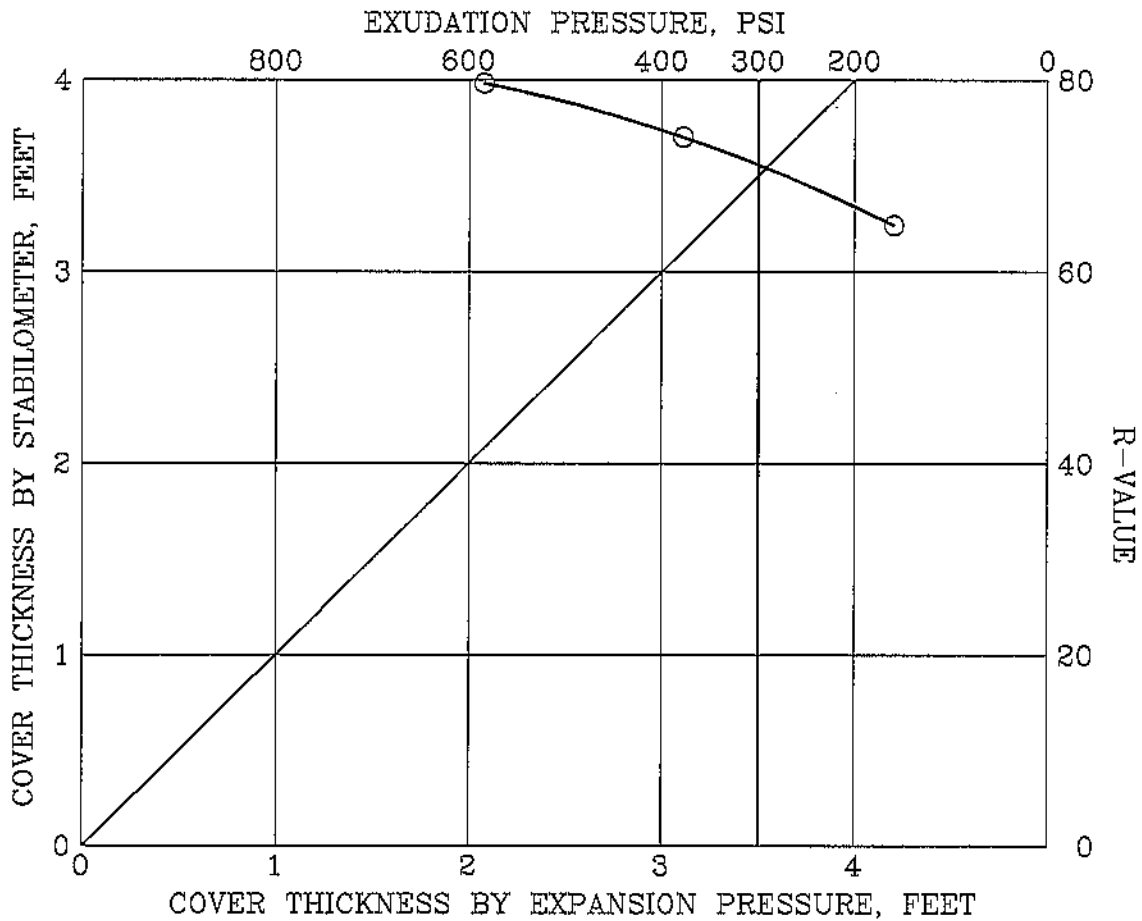

SAMPLE LOCATION : B-2,R-1
 SOIL DESCRIPTION : silty SAND (SM)
 LIQUID LIMIT : SPECIFIC GRAVITY : 2.65
 PLASTIC LIMIT : DATE : 03/09/04

TEST NUMBER	1	2	3	4	5
COMPACTION PRESSURE, PSI	350.0	350.0	350.0		
INITIAL MOISTURE,	1.0	1.0	1.0		
MOISTURE AT COMPACTION,	9.4	10.3	9.0		
DRY DENSITY, PCF	120.2	118.7	117.8		
EXUDATION PRESSURE, PSI	378.0	159.2	584.1		
G.E. (STABILITY), FT	.25	.35	.21		
G.E. (EXPANSION), FT	.00	.00	.00		

R-VALUE BY STABILITY : 71.1

Cal Test Method 301

B82604.01	Fitch Park
Twining Labs, Inc.	R-VALUE TEST Figure No. 24

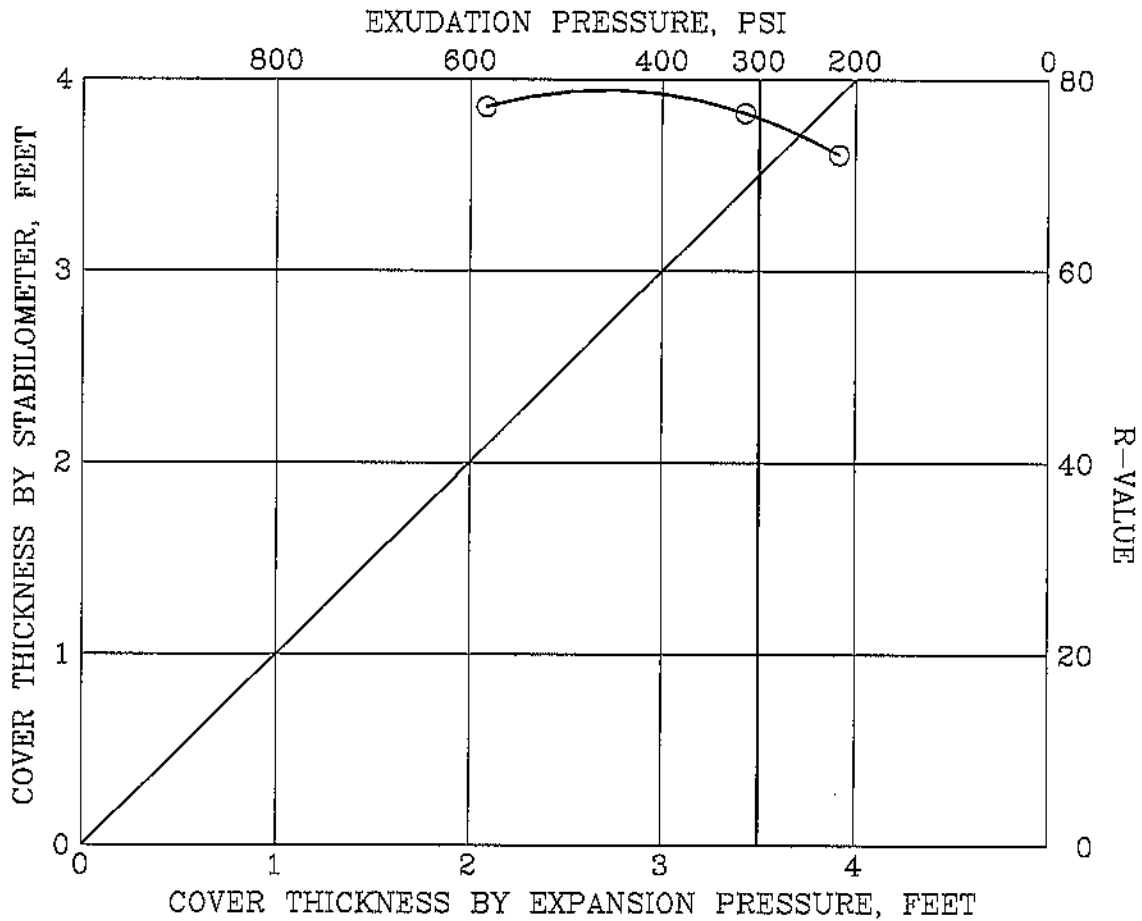

SAMPLE LOCATION : B-4,R-3
 SOIL DESCRIPTION : Silty SAND (SM)
 LIQUID LIMIT : SPECIFIC GRAVITY : 2.65
 PLASTIC LIMIT : DATE : 03/11/04

TEST NUMBER	1	2	3	4	5
COMPACTION PRESSURE, PSI	350.0	350.0	350.0		
INITIAL MOISTURE,	.5	.5	.5		
MOISTURE AT COMPACTION,	13.9	14.3	13.5		
DRY DENSITY, PCF	106.1	105.3	107.0		
EXUDATION PRESSURE, PSI	314.3	217.3	583.3		
G.E. (STABILITY), FT	.25	.30	.24		
G.E. (EXPANSION), FT	.00	.00	.00		

R-VALUE BY STABILITY : 76.0

Cal Test Method 301

B82604.01	Fitch Park
Twining Labs, Inc.	R-VALUE TEST Figure No. 25

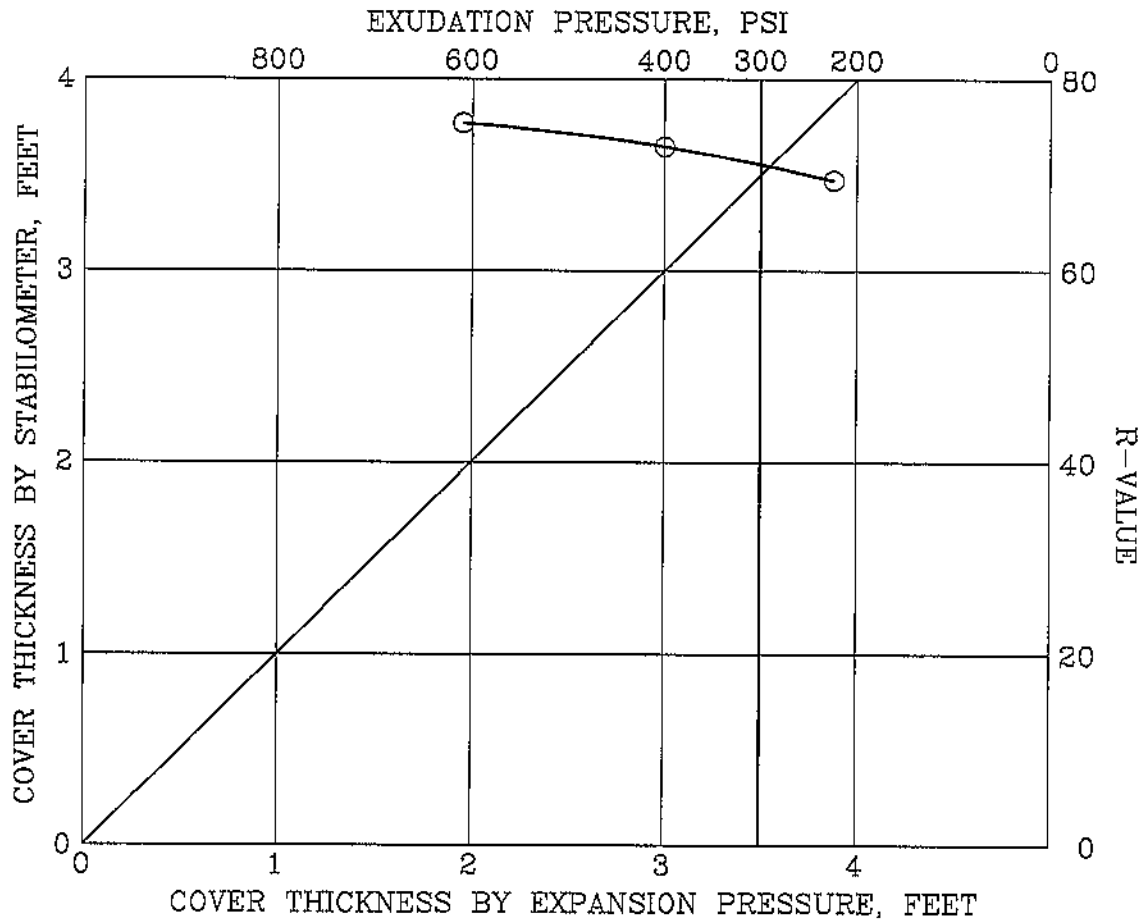

SAMPLE LOCATION : B-6,R-4
 SOIL DESCRIPTION : Poorly Graded SAND (SP)
 LIQUID LIMIT : SPECIFIC GRAVITY : 2.65
 PLASTIC LIMIT : DATE : 03/15/04

TEST NUMBER	1	2	3	4	5
COMPACTION PRESSURE, PSI	350.0	350.0	350.0		
INITIAL MOISTURE,	1.5	1.5	1.4		
MOISTURE AT COMPACTION,	11.7	12.5	13.2		
DRY DENSITY, PCF	107.4	107.8	107.0		
EXUDATION PRESSURE, PSI	609.6	400.3	224.4		
G.E. (STABILITY), FT	.27	.28	.32		
G.E. (EXPANSION), FT	.00	.00	.00		

R-VALUE BY STABILITY : 71.1

Cal Test Method

B82604.01	Fitch Park
Twining Labs, Inc.	R-VALUE TEST Figure No. 26

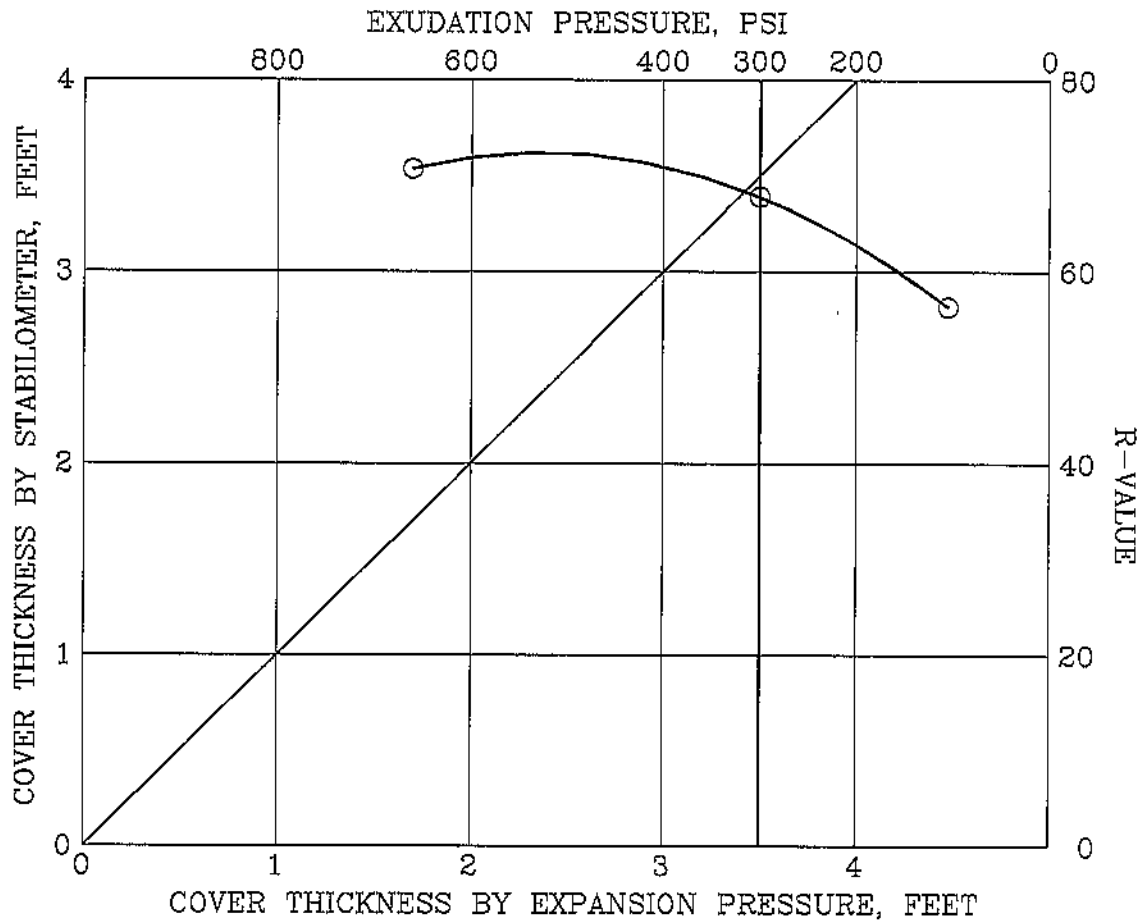

SAMPLE LOCATION : B-10,R-7
 SOIL DESCRIPTION : Silty SAND (SM)
 LIQUID LIMIT : SPECIFIC GRAVITY : 2.65
 PLASTIC LIMIT : DATE : 03/07/04

TEST NUMBER	1	2	3	4	5
COMPACTION PRESSURE, PSI	350.0	350.0	350.0		
INITIAL MOISTURE,	3.1	3.1	3.1		
MOISTURE AT COMPACTION,	10.8	10.0	9.1		
DRY DENSITY, PCF	119.2	116.8	118.8		
EXUDATION PRESSURE, PSI	105.0	300.0	660.5		
G.E. (STABILITY), FT	.42	.34	.30		
G.E. (EXPANSION), FT	.00	.00	.00		

R-VALUE BY STABILITY : 67.8

Cal Test Method 301

B82604.01	Fitch Park
Twining Labs, Inc.	R-VALUE TEST Figure No. 28

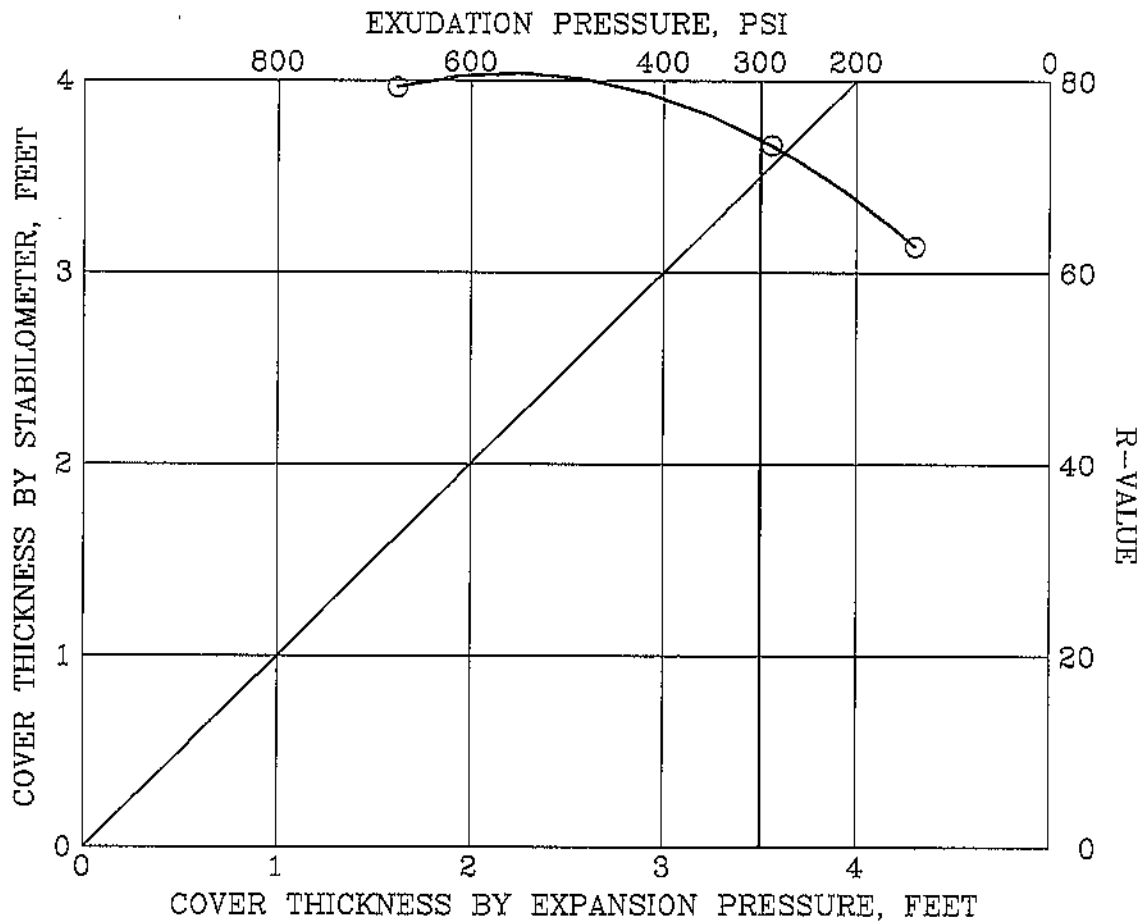

SAMPLE LOCATION : B-11,R-8
 SOIL DESCRIPTION : Silty SAND (SM)
 LIQUID LIMIT : SPECIFIC GRAVITY : 2.65
 PLASTIC LIMIT : DATE : 03/11/04

TEST NUMBER	1	2	3	4	5
COMPACTION PRESSURE, PSI	350.0	350.0	350.0		
INITIAL MOISTURE,	.5	.5	.5		
MOISTURE AT COMPACTION,	13.1	11.8	10.1		
DRY DENSITY, PCF	111.0	111.9	110.7		
EXUDATION PRESSURE, PSI	139.3	288.1	676.4		
G.E. (STABILITY), FT	.36	.27	.22		
G.E. (EXPANSION), FT	.00	.00	.00		

R-VALUE BY STABILITY : 73.8

Cal Test Method 301

B82604.01	Fitch Park
Twining Labs, Inc.	R-VALUE TEST Figure No. 29

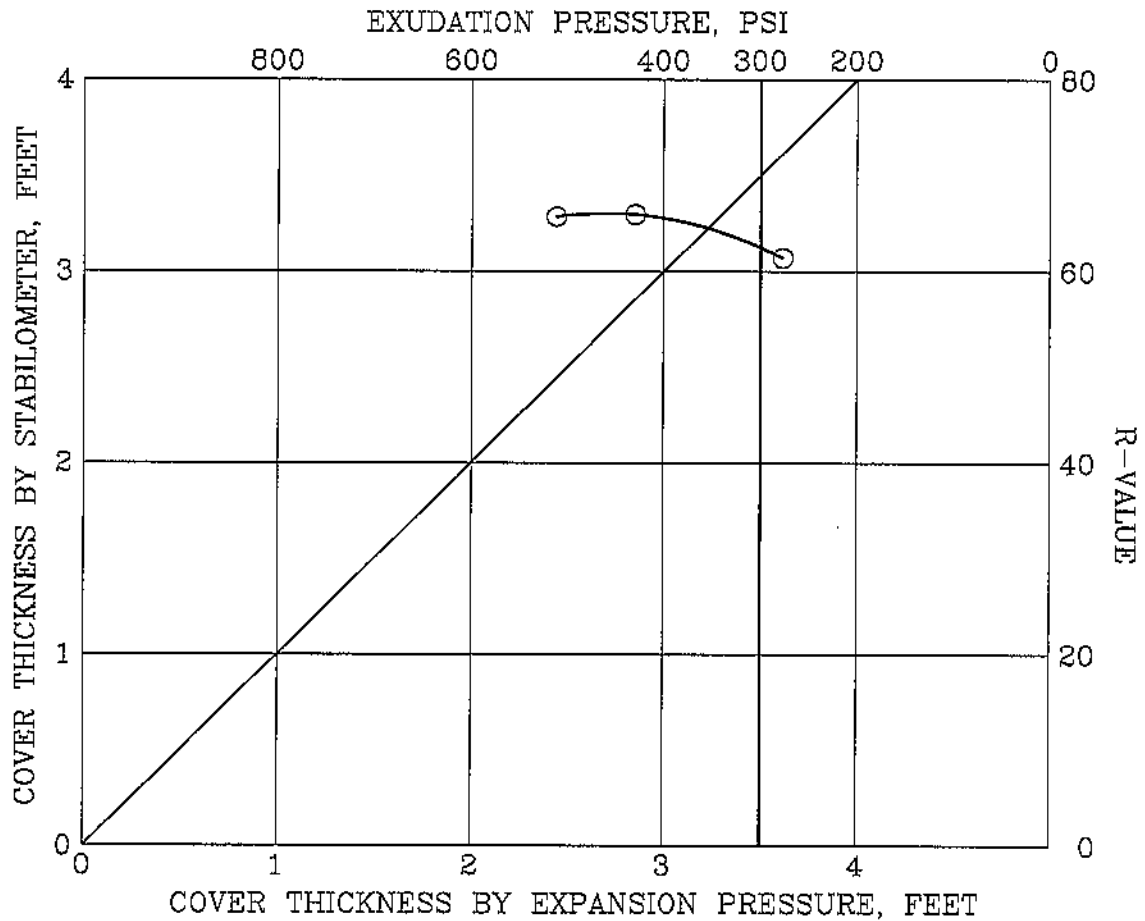

SAMPLE LOCATION : B-12,R-9
 SOIL DESCRIPTION : Silty SAND (SM)
 LIQUID LIMIT : SPECIFIC GRAVITY : 2.65
 PLASTIC LIMIT : DATE : 03/30/04

TEST NUMBER	1	2	3	4	5
COMPACTION PRESSURE, PSI	350.0	350.0	350.0		
INITIAL MOISTURE,	1.0	1.0	1.0		
MOISTURE AT COMPACTION,	10.7	9.8	10.3		
DRY DENSITY, PCF	119.8	121.0	119.6		
EXUDATION PRESSURE, PSI	276.9	511.7	429.7		
G.E. (STABILITY), FT	.37	.33	.34		
G.E. (EXPANSION), FT	.00	.00	.00		

R-VALUE BY STABILITY : 62.5

Cal Test Method 301

B82604.01	Fitch Park
Twining Labs, Inc.	R-VALUE TEST Figure No. 30

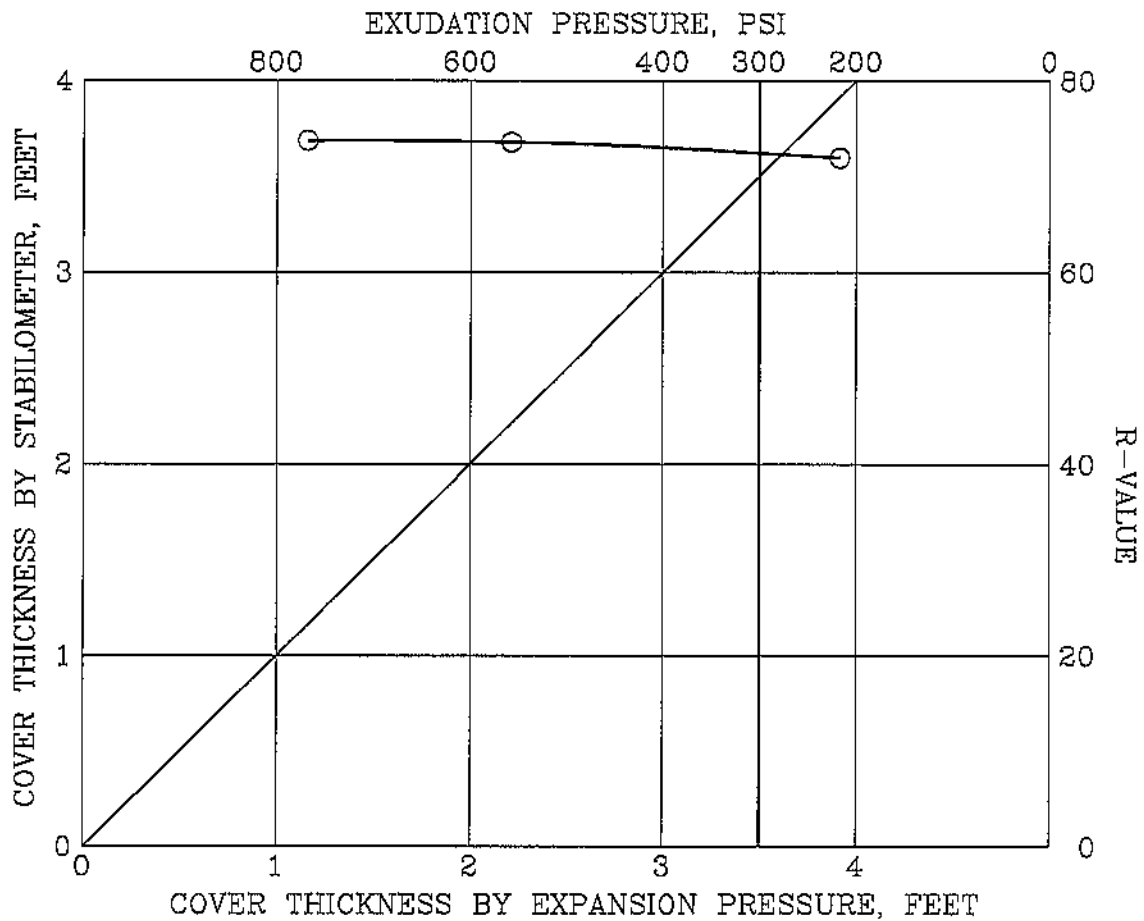

SAMPLE LOCATION : B-18,R-13
 SOIL DESCRIPTION : Silty SAND (SM)
 LIQUID LIMIT : SPECIFIC GRAVITY : 2.65
 PLASTIC LIMIT : DATE : 03/18/04

TEST NUMBER	1	2	3	4	5
COMPACTION PRESSURE, PSI	350.0	350.0	350.0		
INITIAL MOISTURE,	.5	.5	.5		
MOISTURE AT COMPACTION,	10.1	11.0	10.6		
DRY DENSITY, PCF	111.7	111.5	111.6		
EXUDATION PRESSURE, PSI	767.9	217.3	557.9		
G.E. (STABILITY), FT	.28	.29	.28		
G.E. (EXPANSION), FT	.00	.00	.00		

R-VALUE BY STABILITY : 72.5

Cal Test Method 301

B82604.01	Fitch Park
Twining Labs, Inc.	R-VALUE TEST Figure No. 33

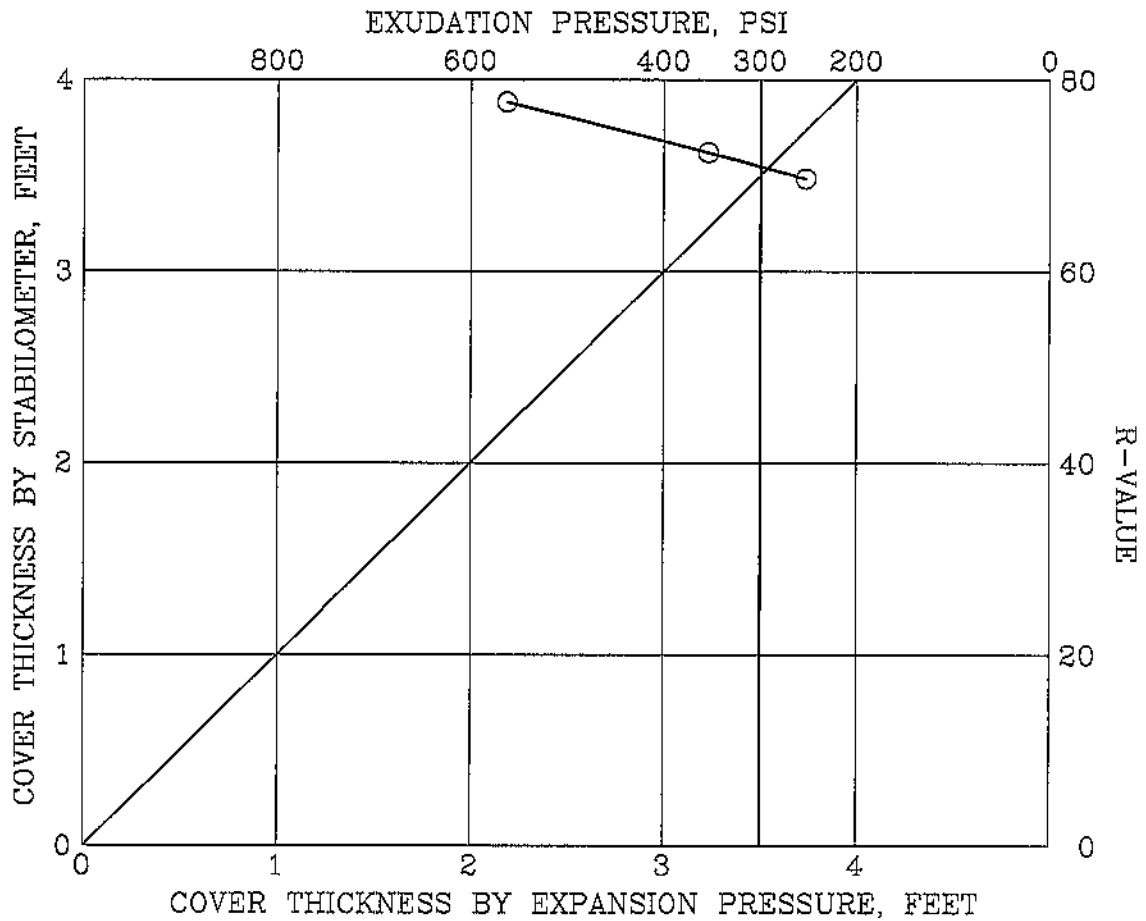

SAMPLE LOCATION : B-19,R-14
 SOIL DESCRIPTION : Poorly Graded SAND with Silt (SP-SM)
 LIQUID LIMIT : SPECIFIC GRAVITY : 2.65
 PLASTIC LIMIT : DATE : 03/29/04

TEST NUMBER	1	2	3	4	5
COMPACTION PRESSURE, PSI	350.0	350.0	350.0		
INITIAL MOISTURE,	.1	.1	.1		
MOISTURE AT COMPACTION,	13.0	12.6	11.7		
DRY DENSITY, PCF	108.7	108.9	108.8		
EXUDATION PRESSURE, PSI	253.1	354.1	562.6		
G.E. (STABILITY), FT	.32	.29	.25		
G.E. (EXPANSION), FT	.00	.00	.00		

R-VALUE BY STABILITY : 70.9

Cal Test Method 301

B82604.01

Fitch Park

Twining
Labs, Inc.

R-VALUE TEST

Figure No. 34

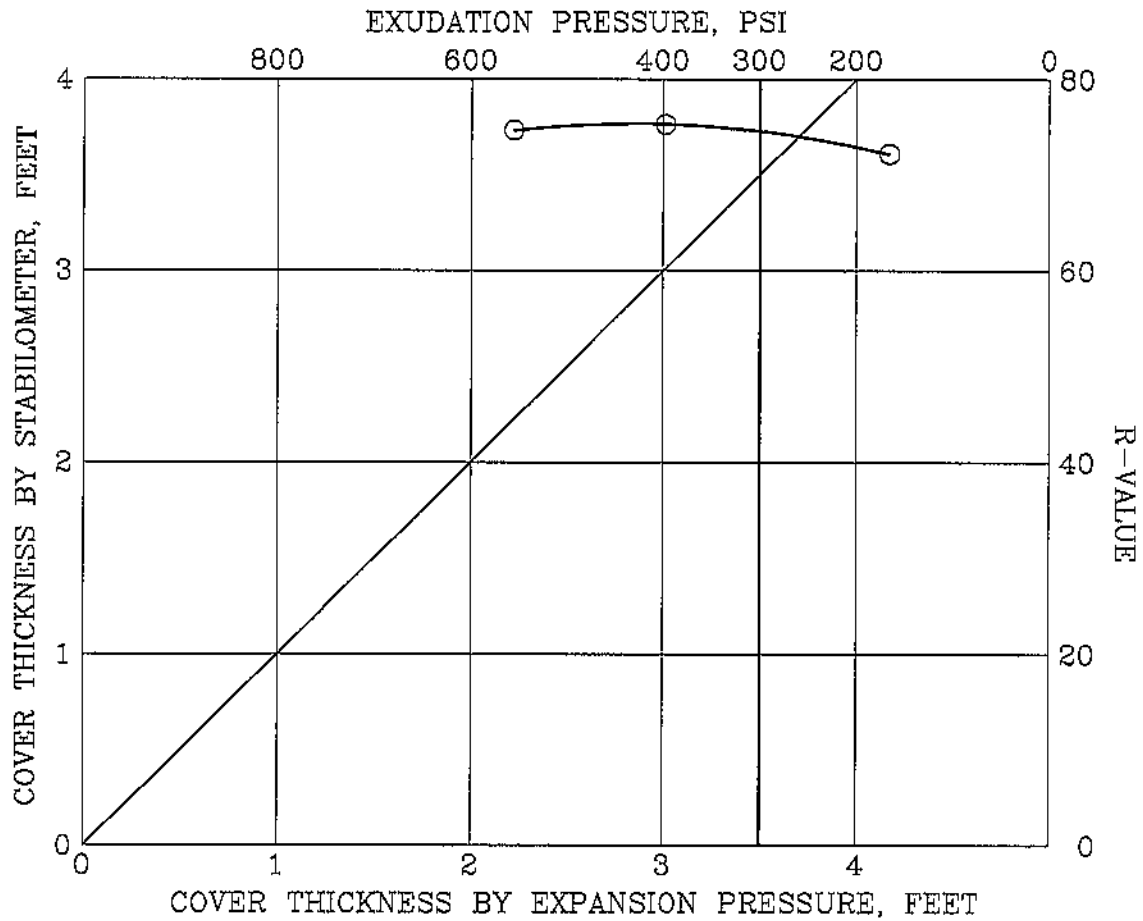

SAMPLE LOCATION : B-23,R-17
 SOIL DESCRIPTION : Silty SAND (SM)
 LIQUID LIMIT : SPECIFIC GRAVITY : 2.65
 PLASTIC LIMIT : DATE : 03/11/04

TEST NUMBER	1	2	3	4	5
COMPACTION PRESSURE, PSI	350.0	350.0	350.0		
INITIAL MOISTURE,	.5	.5	.5		
MOISTURE AT COMPACTION,	13.5	12.6	13.1		
DRY DENSITY, PCF	108.1	109.0	107.3		
EXUDATION PRESSURE, PSI	166.3	555.5	397.9		
G.E. (STABILITY), FT	.28	.27	.27		
G.E. (EXPANSION), FT	.00	.00	.00		

R-VALUE BY STABILITY : 74.5

Cal Test Method 301

B82604.01	Fitch Park
Twining Labs, Inc.	R-VALUE TEST Figure No. 35

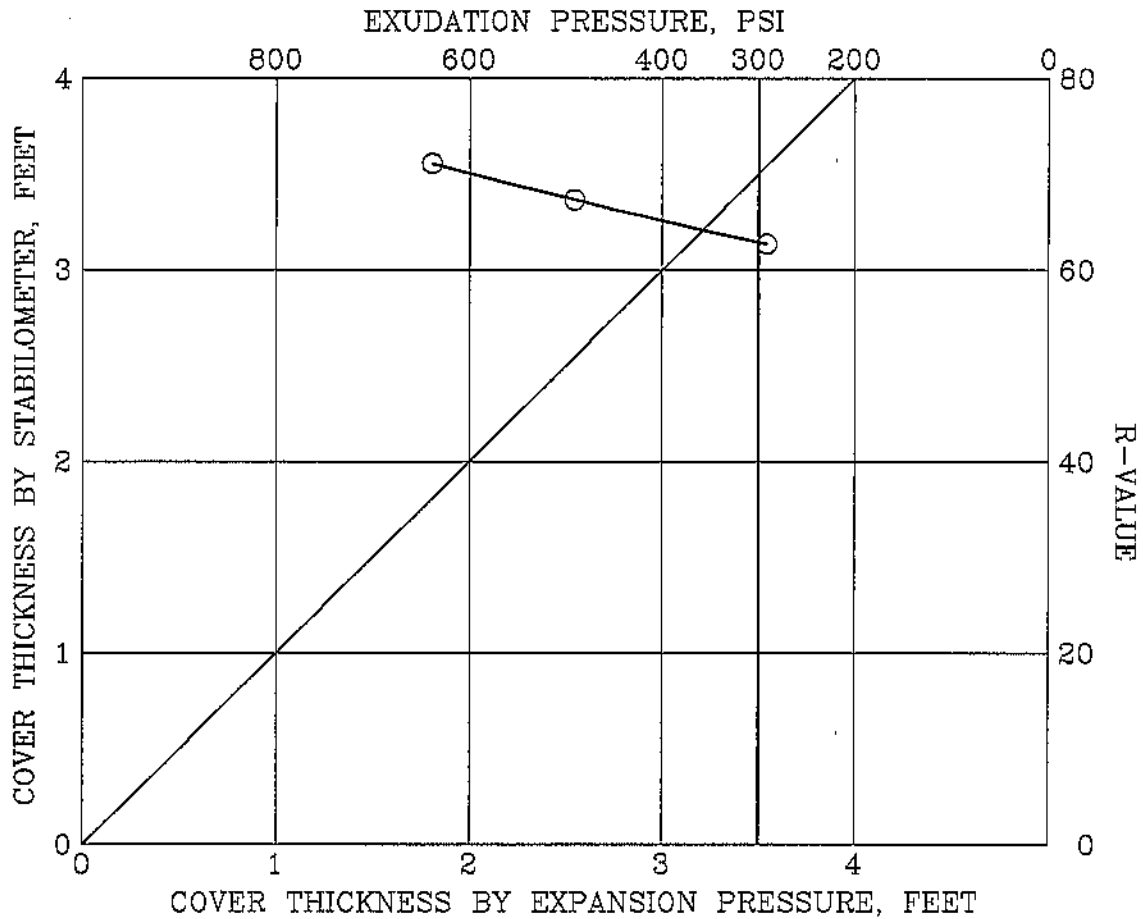

SAMPLE LOCATION : B-24,R-18
 SOIL DESCRIPTION : Silty SAND (SM)
 LIQUID LIMIT : SPECIFIC GRAVITY : 2.65
 PLASTIC LIMIT : DATE : 03/29/04

TEST NUMBER	1	2	3	4	5
COMPACTION PRESSURE, PSI	350.0	350.0	350.0		
INITIAL MOISTURE,	4.2	4.2	4.2		
MOISTURE AT COMPACTION,	11.6	12.9	12.0		
DRY DENSITY, PCF	113.3	111.1	112.3		
EXUDATION PRESSURE, PSI	638.2	291.3	491.0		
G.E. (STABILITY), FT	.31	.39	.34		
G.E. (EXPANSION), FT	.00	.00	.00		

R-VALUE BY STABILITY : 62.9

Cal Test Method 301

B82604.01

Fitch Park

Twining
 Labs, Inc.

R-VALUE TEST

Figure No. 36

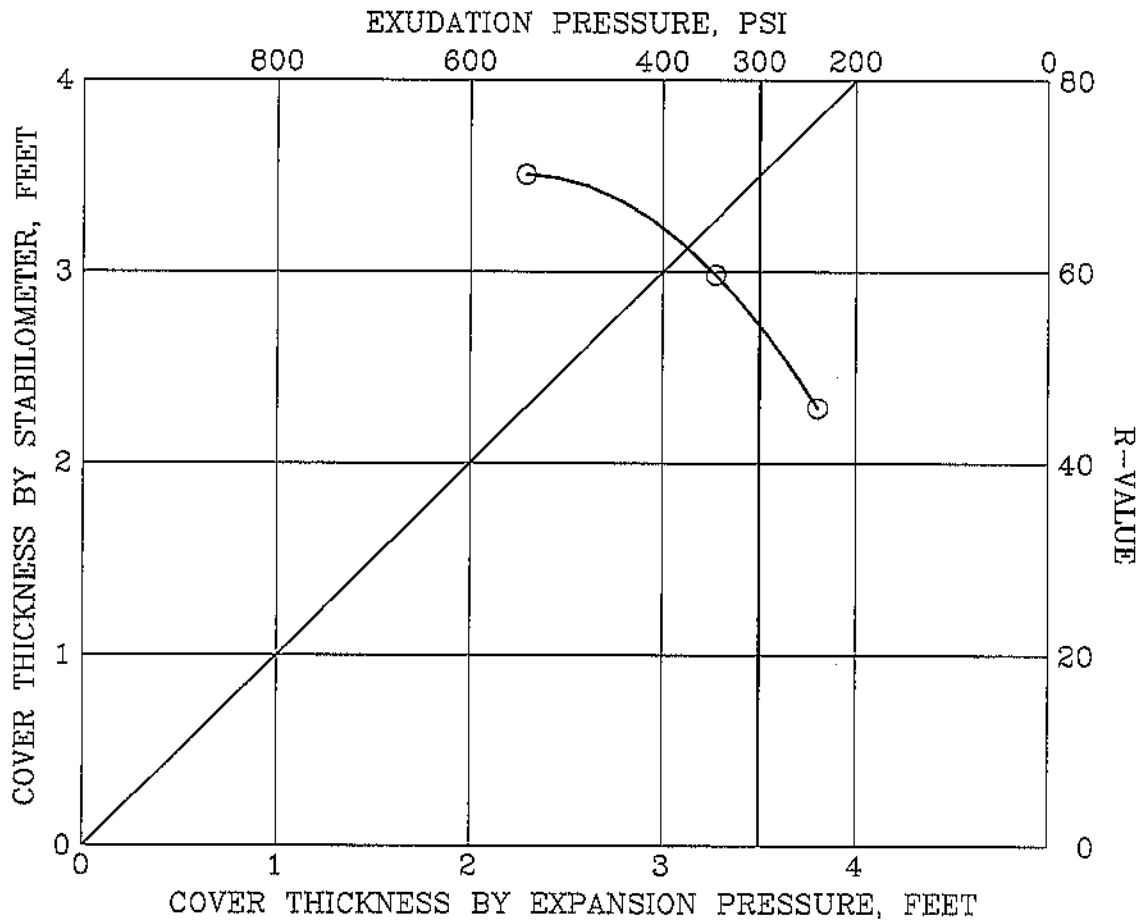

SAMPLE LOCATION : B-27,R-20
 SOIL DESCRIPTION : Silty SAND (SM)
 LIQUID LIMIT : SPECIFIC GRAVITY : 2.65
 PLASTIC LIMIT : DATE : 03/29/04

TEST NUMBER	1	2	3	4	5
COMPACTION PRESSURE, PSI	350.0	350.0	350.0		
INITIAL MOISTURE,	4.7	4.7	4.7		
MOISTURE AT COMPACTION,	11.3	10.4	11.7		
DRY DENSITY, PCF	120.1	121.1	119.4		
EXUDATION PRESSURE, PSI	345.4	541.9	239.5		
G.E. (STABILITY), FT	.41	.30	.54		
G.E. (EXPANSION), FT	.00	.00	.00		

R-VALUE BY STABILITY : 54.4

Cal Test Method 301

B82604.01

Fitch Park

Twining
Labs, Inc.

R-VALUE TEST

Figure No. 37

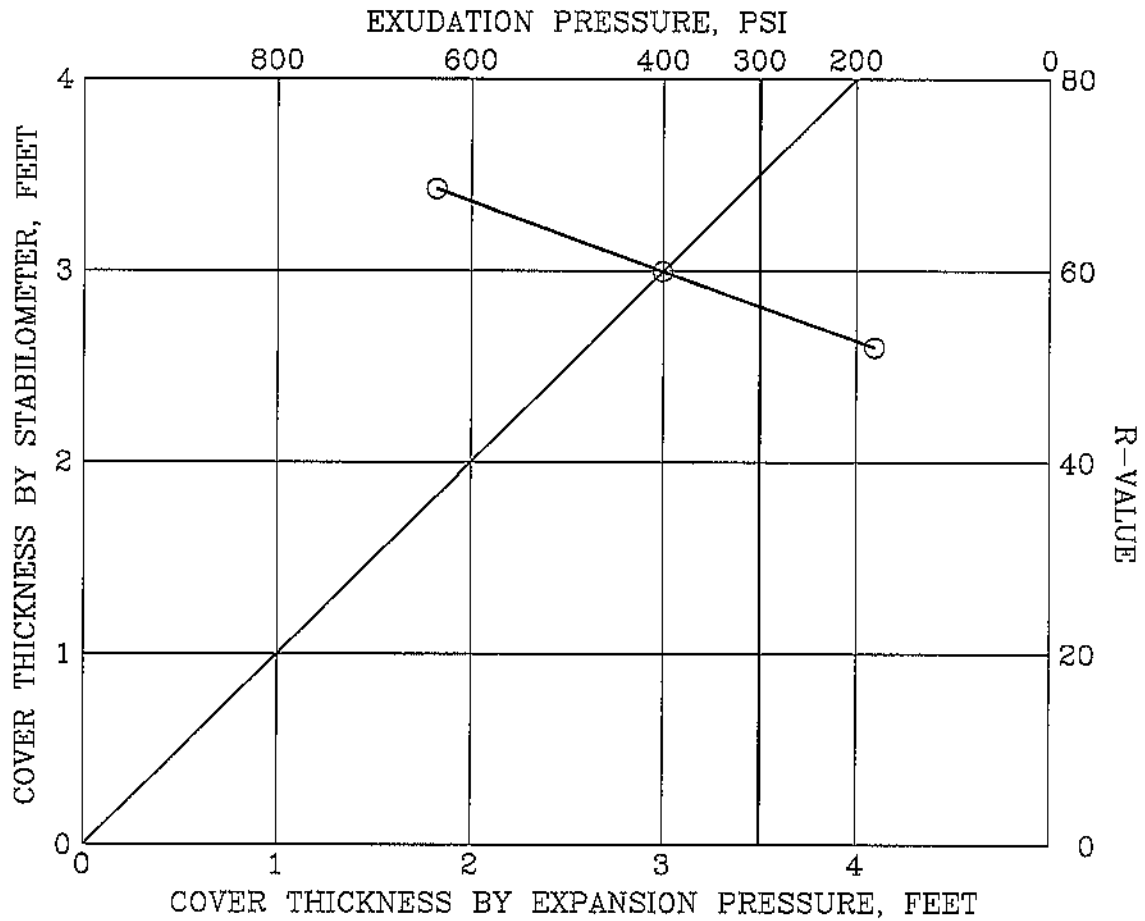

SAMPLE LOCATION : B-30,R-22
 SOIL DESCRIPTION : Silty SAND (SM)
 LIQUID LIMIT : SPECIFIC GRAVITY : 2.65
 PLASTIC LIMIT : DATE : 03/15/04

TEST NUMBER	1	2	3	4	5
COMPACTION PRESSURE, PSI	350.0	350.0	350.0		
INITIAL MOISTURE,	5.8	5.8	5.8		
MOISTURE AT COMPACTION,	12.0	11.1	11.6		
DRY DENSITY, PCF	111.8	114.6	113.8		
EXUDATION PRESSURE, PSI	181.4	635.8	401.1		
G.E. (STABILITY), FT	.48	.30	.38		
G.E. (EXPANSION), FT	.00	.00	.00		

R-VALUE BY STABILITY : 56.2

Cal Test Method 301

B82604.01	Fitch Park
Twining Labs, Inc.	R-VALUE TEST Figure No. 38

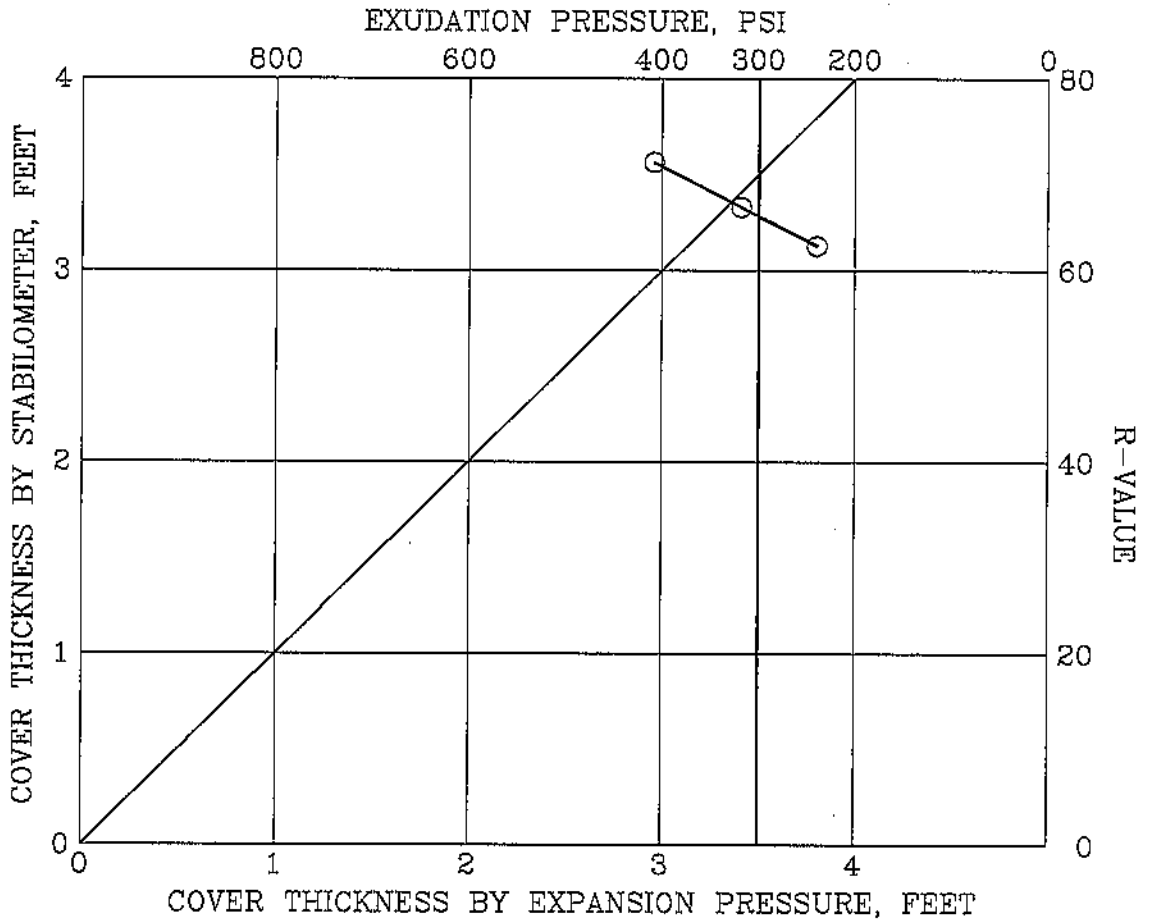

SAMPLE LOCATION : B-32,R-24,0.7-3.5'
 SOIL DESCRIPTION : Silty SAND (SM)
 LIQUID LIMIT : SPECIFIC GRAVITY : 2.65
 PLASTIC LIMIT : DATE : 03/23/04

TEST NUMBER	1	2	3	4	5
COMPACTION PRESSURE, PSI	350.0	350.0	350.0		
INITIAL MOISTURE,	2.0	2.0	2.0		
MOISTURE AT COMPACTION,	10.5	11.4	11.0		
DRY DENSITY, PCF	117.8	116.6	117.5		
EXUDATION PRESSURE, PSI	408.2	239.5	318.3		
G.E. (STABILITY), FT	.28	.36	.32		
G.E. (EXPANSION), FT	.00	.00	.00		

R-VALUE BY STABILITY : 65.6

Cal Test Method 301

B82604.01	Fitch Park
Twining Labs, Inc.	R-VALUE TEST
	Figure No. 39

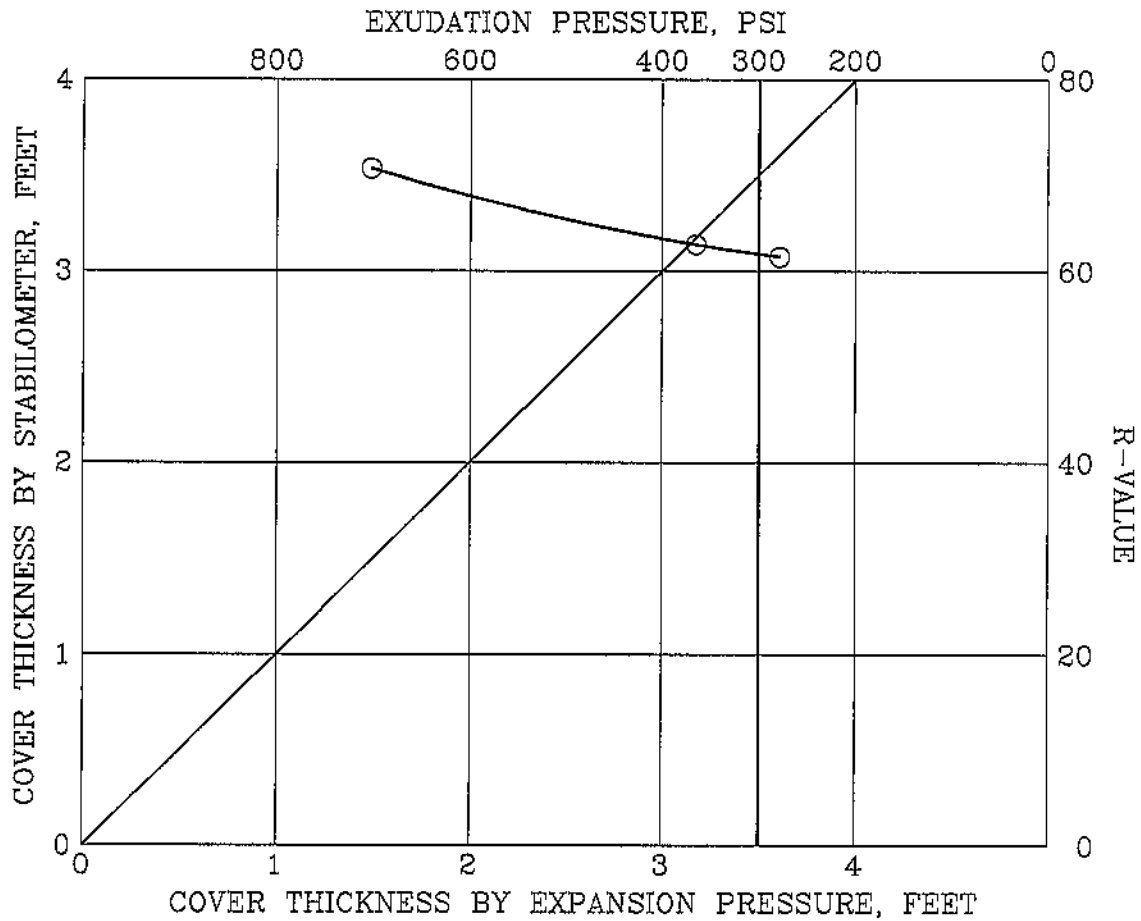

SAMPLE LOCATION : B-34,R-25 0.5-3.5
 SOIL DESCRIPTION : Silty SAND (SM)
 LIQUID LIMIT : SPECIFIC GRAVITY : 2.65
 PLASTIC LIMIT : DATE : 03/26/04

TEST NUMBER	1	2	3	4	5
COMPACTION PRESSURE, PSI	350.0	350.0	350.0		
INITIAL MOISTURE,	3.1	3.1	3.1		
MOISTURE AT COMPACTION,	11.7	10.8	11.4		
DRY DENSITY, PCF	118.3	118.4	118.6		
EXUDATION PRESSURE, PSI	278.5	702.7	365.3		
G.E. (STABILITY), FT	.37	.28	.36		
G.E. (EXPANSION), FT	.00	.00	.00		

R-VALUE BY STABILITY : 61.8

Cal test Method 301

B82604.01	Fitch Park
Twining Labs, Inc.	R-VALUE TEST Figure No. 40

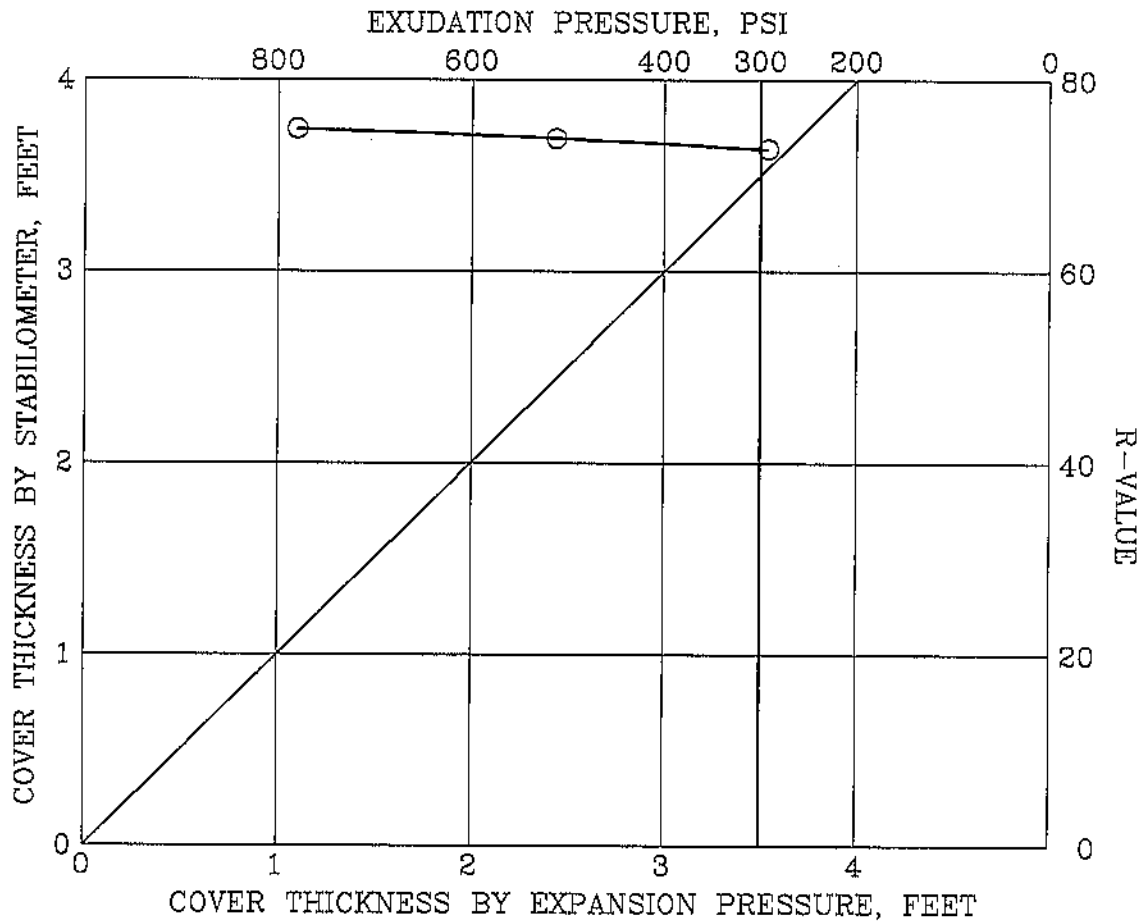

SAMPLE LOCATION : B-36,R-27 0.5-3.5
 SOIL DESCRIPTION : Silty SAND (SM)
 LIQUID LIMIT : SPECIFIC GRAVITY : 2.65
 PLASTIC LIMIT : DATE : 03/24/04

TEST NUMBER	1	2	3	4	5
COMPACTION PRESSURE, PSI	350.0	350.0	350.0		
INITIAL MOISTURE,	3.1	3.1	3.1		
MOISTURE AT COMPACTION,	11.7	13.4	12.6		
DRY DENSITY, PCF	114.9	114.7	115.1		
EXUDATION PRESSURE, PSI	780.7	292.1	512.5		
G.E. (STABILITY), FT	.24	.26	.25		
G.E. (EXPANSION), FT	.00	.00	.00		

R-VALUE BY STABILITY : 72.8

Test Method Cal 301

B82604.01

Fitch Park

Twining
Labs, Inc.

R-VALUE TEST

Figure No. 41

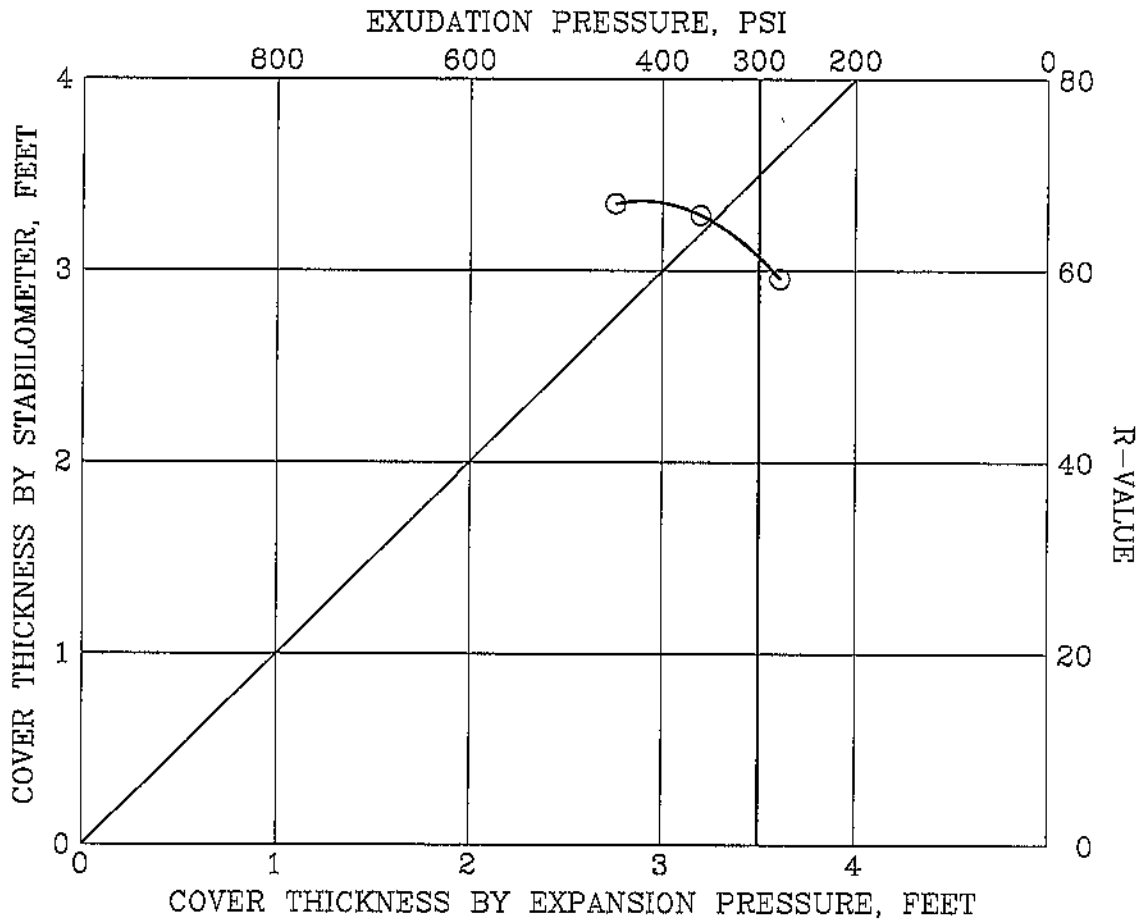

SAMPLE LOCATION : B-38,R-28 0.5-3.5'
 SOIL DESCRIPTION : Silty SAND (SM)
 LIQUID LIMIT : SPECIFIC GRAVITY : 2.65
 PLASTIC LIMIT : DATE : 03/26/04

TEST NUMBER	1	2	3	4	5
COMPACTION PRESSURE, PSI	350.0	350.0	350.0		
INITIAL MOISTURE,	2.0	2.0	2.0		
MOISTURE AT COMPACTION,	10.5	11.4	11.0		
DRY DENSITY, PCF	120.1	120.3	223.1		
EXUDATION PRESSURE, PSI	448.8	278.5	361.3		
G.E. (STABILITY), FT	.32	.38	.33		
G.E. (EXPANSION), FT	.00	.00	.00		

R-VALUE BY STABILITY : 61.4

Cal Test Method 301

B82604.01

Fitch Park

Twining
Labs, Inc.

R-VALUE TEST

Figure No. 42

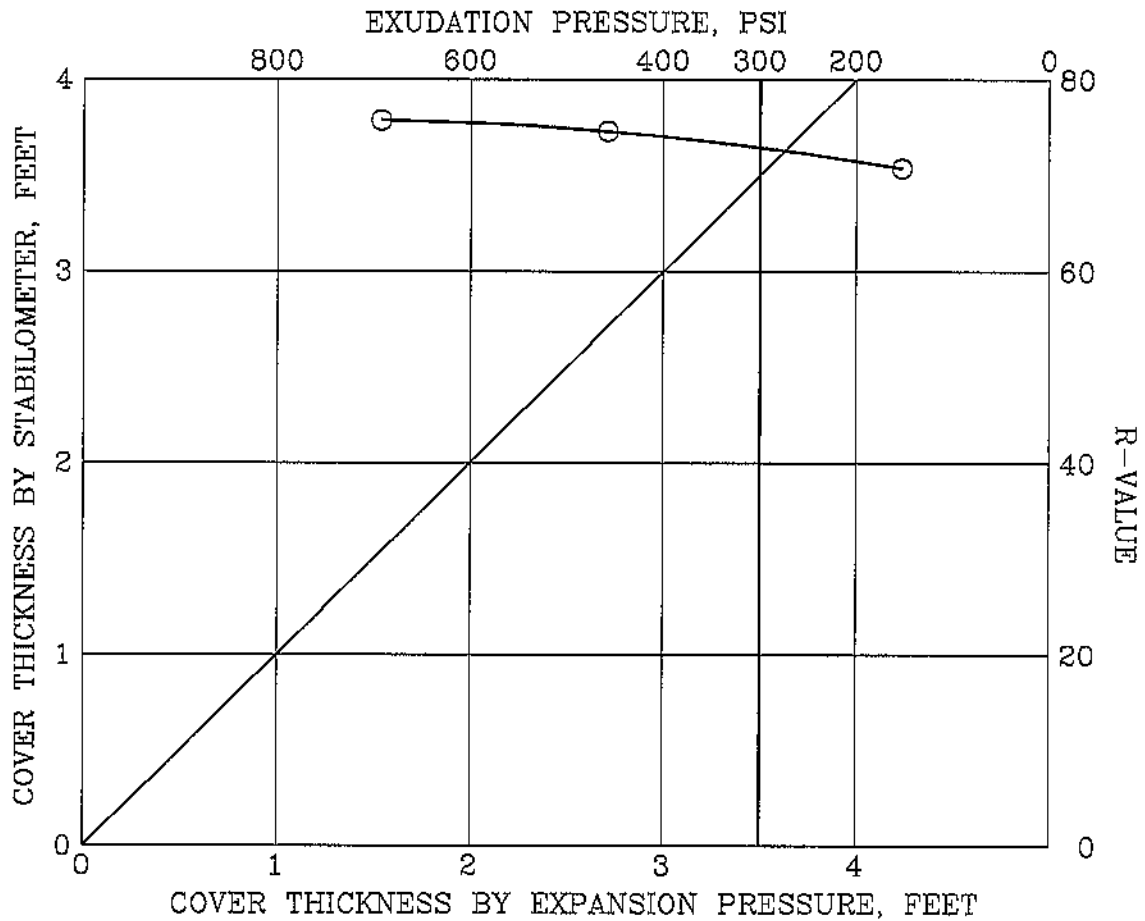

SAMPLE LOCATION : B-42,R-31
 SOIL DESCRIPTION : Silty SAND (SM)
 LIQUID LIMIT : SPECIFIC GRAVITY : 2.65
 PLASTIC LIMIT : DATE : 03/19/04

TEST NUMBER	1	2	3	4	5
COMPACTION PRESSURE, PSI	350.0	350.0	350.0		
INITIAL MOISTURE,	2.0	2.0	2.0		
MOISTURE AT COMPACTION,	11.4	13.1	12.2		
DRY DENSITY, PCF	110.3	109.4	111.0		
EXUDATION PRESSURE, PSI	692.3	152.8	457.6		
G.E. (STABILITY), FT	.23	.28	.26		
G.E. (EXPANSION), FT	.00	.00	.00		

R-VALUE BY STABILITY : 72.9

Cal Test Method 301

B82604.01	Fitch Park
Twining Labs, Inc.	R-VALUE TEST Figure No. 44

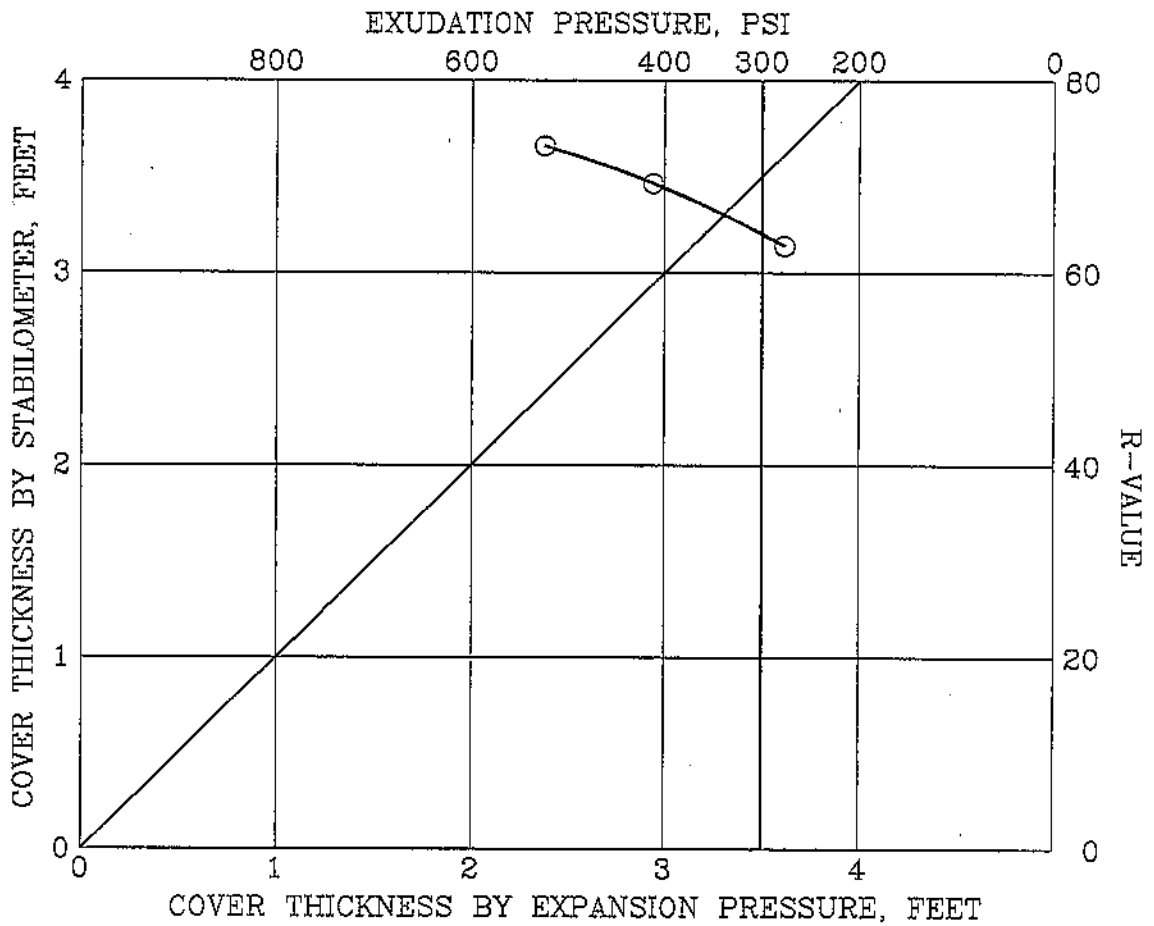

SAMPLE LOCATION : B-44,R-33
 SOIL DESCRIPTION : Poorly Graded SAND (SP)
 LIQUID LIMIT : SPECIFIC GRAVITY : 2.65
 PLASTIC LIMIT : DATE : 03/22/04

TEST NUMBER	1	2	3	4	5
COMPACTION PRESSURE, PSI	350.0	350.0	350.0		
INITIAL MOISTURE,	3.0	3.0	3.0		
MOISTURE AT COMPACTION,	12.5	12.0	13.1		
DRY DENSITY, PCF	113.8	114.0	114.0		
EXUDATION PRESSURE, PSI	412.2	524.4	276.9		
G.E. (STABILITY), FT	.31	.28	.36		
G.E. (EXPANSION), FT	.00	.00	.00		

R-VALUE BY STABILITY : 64.0

Cal Test Method

B82604.01

Fitch Park

Twining
 Labs, Inc.

R-VALUE TEST

Figure No. 45

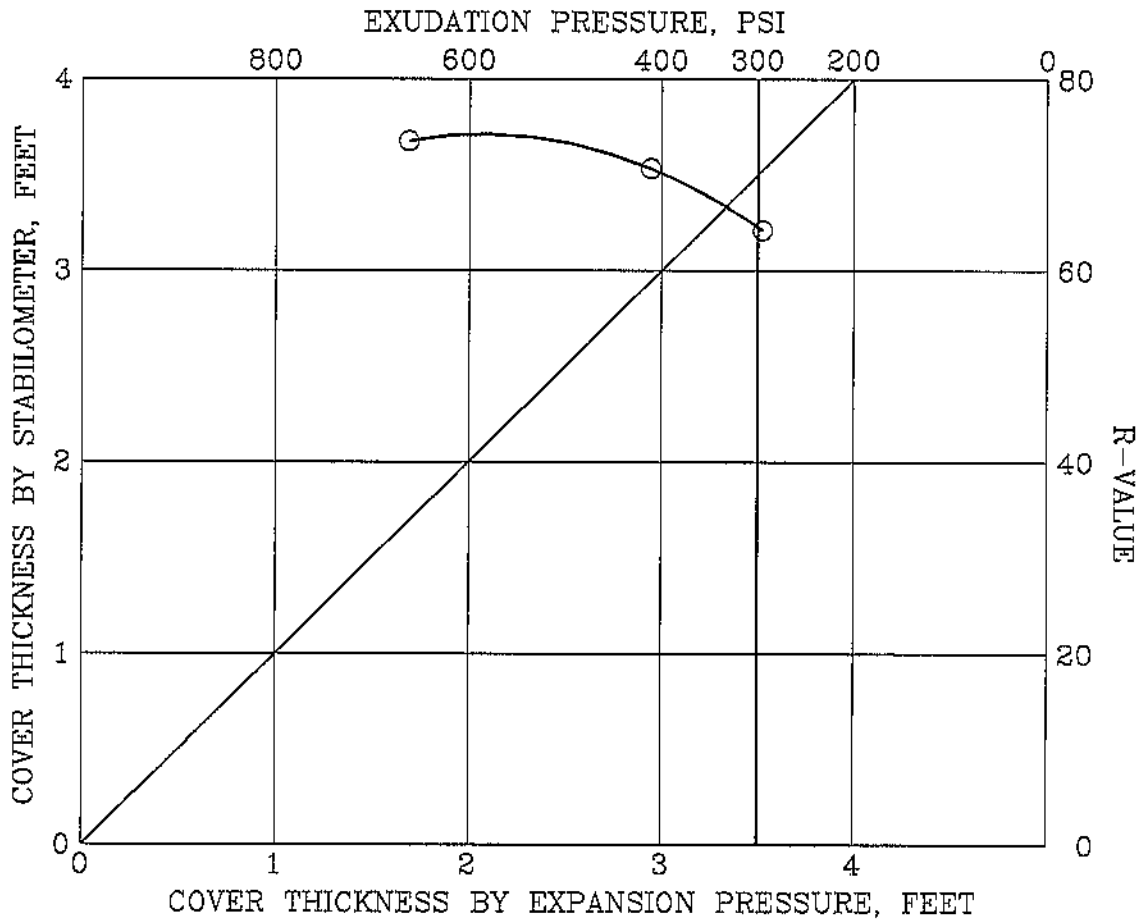

SAMPLE LOCATION : B-46,R-34
 SOIL DESCRIPTION : Silty SAND (SM)
 LIQUID LIMIT : SPECIFIC GRAVITY : 2.65
 PLASTIC LIMIT : DATE : 03/22/04

TEST NUMBER	1	2	3	4	5
COMPACTION PRESSURE, PSI	350.0	350.0	350.0		
INITIAL MOISTURE,	3.1	3.1	3.1		
MOISTURE AT COMPACTION,	12.6	12.1	13.2		
DRY DENSITY, PCF	112.1	113.0	112.5		
EXUDATION PRESSURE, PSI	411.4	662.1	295.2		
G.E. (STABILITY), FT	.30	.26	.36		
G.E. (EXPANSION), FT	.00	.00	.00		

R-VALUE BY STABILITY : 64.5

Cal Test Method 301

B82604.01

Fitch Park

Twining
Labs, Inc.

R-VALUE TEST

Figure No. 46

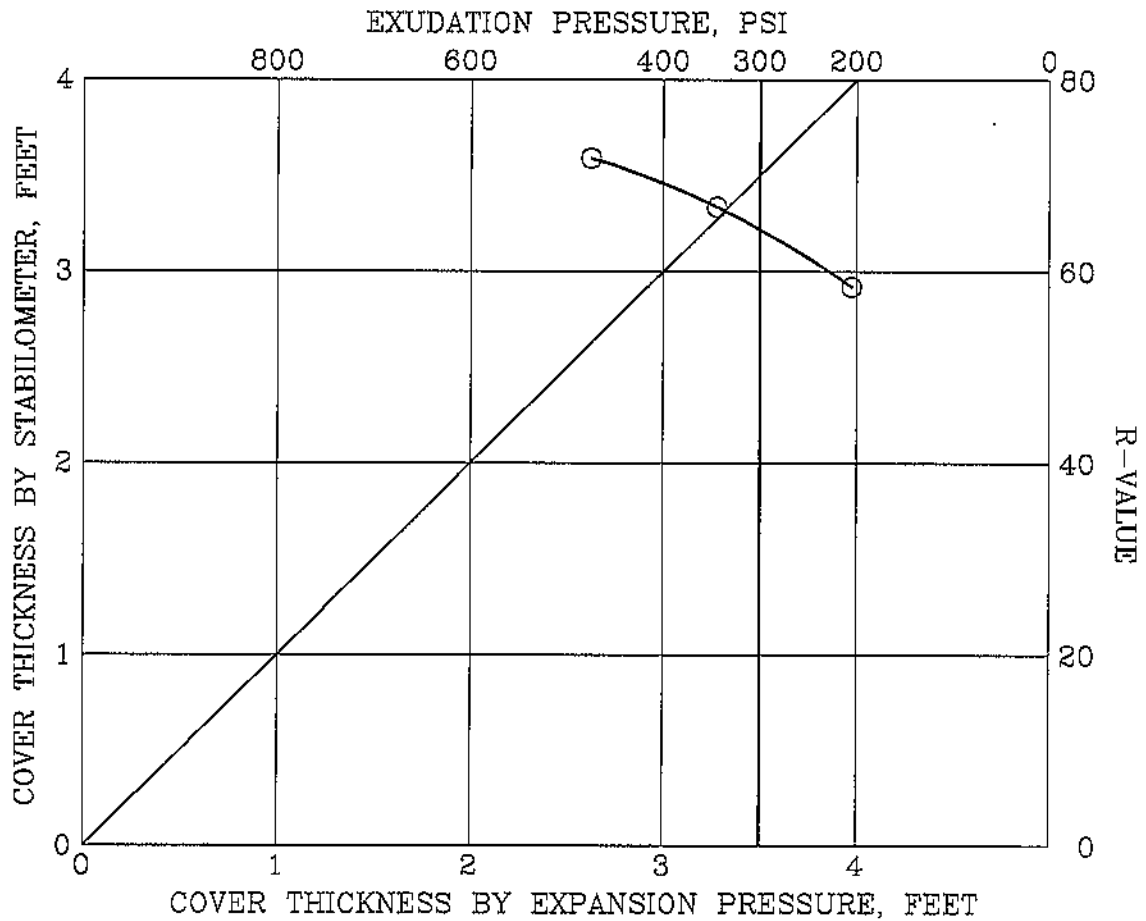

SAMPLE LOCATION : B-48,R-36
 SOIL DESCRIPTION : silty SAND (SM)
 LIQUID LIMIT : SPECIFIC GRAVITY : 2.65
 PLASTIC LIMIT : DATE : 03/19/04

TEST NUMBER	1	2	3	4	5
COMPACTION PRESSURE, PSI	350.0	350.0	350.0		
INITIAL MOISTURE,	4.7	4.7	4.7		
MOISTURE AT COMPACTION,	11.3	10.4	9.9		
DRY DENSITY, PCF	120.0	120.8	121.3		
EXUDATION PRESSURE, PSI	205.3	344.6	475.1		
G.E. (STABILITY), FT	.41	.33	.27		
G.E. (EXPANSION), FT	.00	.00	.00		

R-VALUE BY STABILITY : 64.4

Cal Test Method 301

B82604.01

Fitch Park

Twining
Labs, Inc.

R-VALUE TEST

Figure No. 47

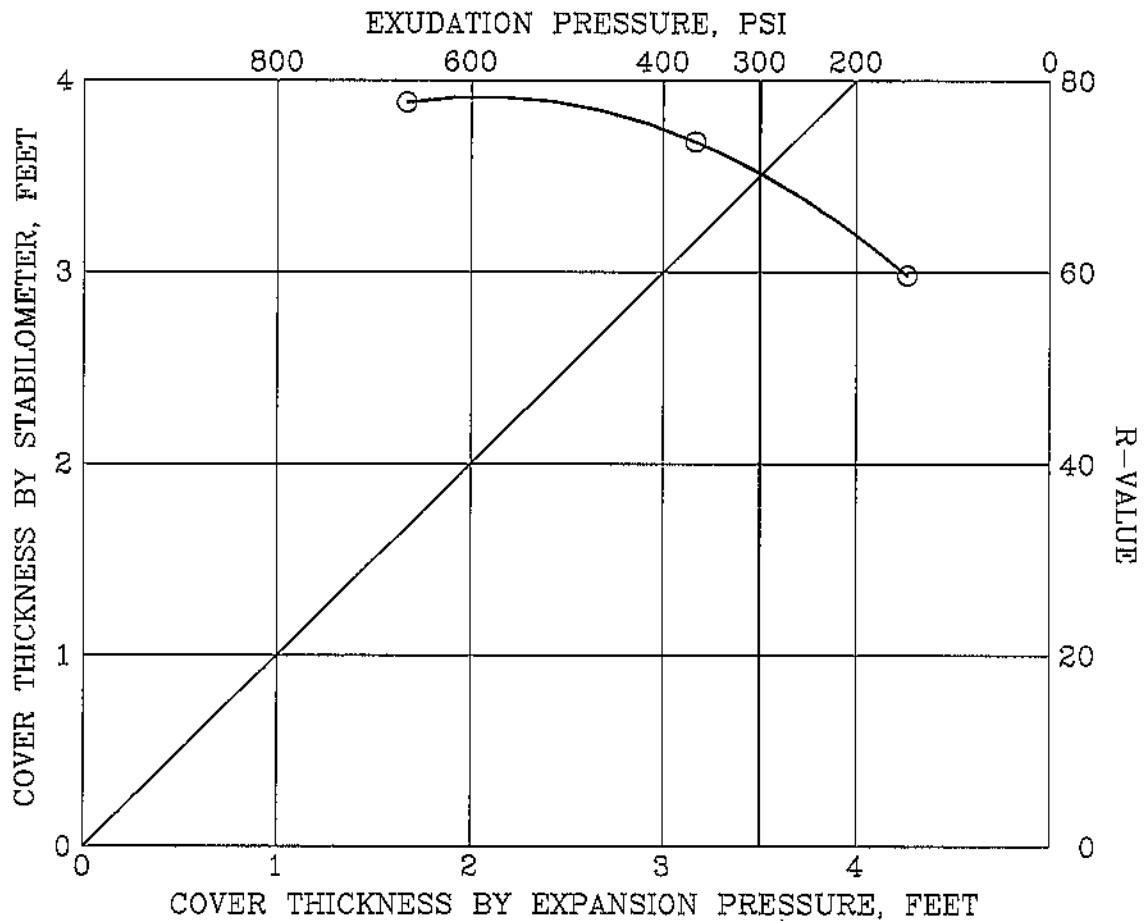

SAMPLE LOCATION : B-50,R-37
 SOIL DESCRIPTION : Silty SAND (SM)
 LIQUID LIMIT : SPECIFIC GRAVITY : 2.65
 PLASTIC LIMIT : DATE : 03/19/04

TEST NUMBER	1	2	3	4	5
COMPACTION PRESSURE, PSI	350.0	350.0	350.0		
INITIAL MOISTURE,	4.2	4.2	4.2		
MOISTURE AT COMPACTION,	10.7	9.4	8.9		
DRY DENSITY, PCF	119.4	121.2	122.5		
EXUDATION PRESSURE, PSI	147.2	366.9	666.9		
G.E. (STABILITY), FT	.40	.27	.21		
G.E. (EXPANSION), FT	.00	.00	.00		

R-VALUE BY STABILITY : 70.3

Cal Test Method 301

B82604.01	Fitch Park
Twining Labs, Inc.	R-VALUE TEST Figure No. 48

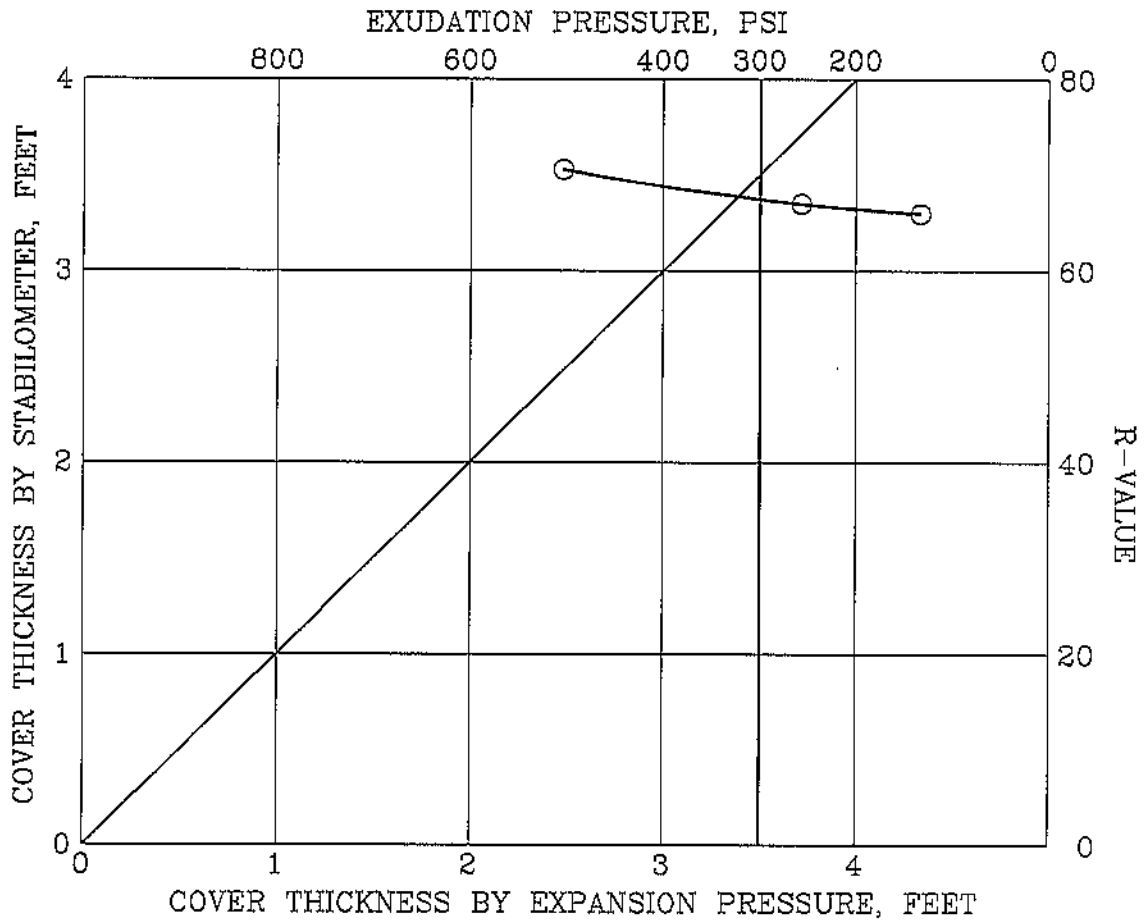

SAMPLE LOCATION : B-52, R-39
 SOIL DESCRIPTION : Silty SAND (SM)
 LIQUID LIMIT : SPECIFIC GRAVITY : 2.65
 PLASTIC LIMIT : DATE : 03/19/04

TEST NUMBER	1	2	3	4	5
COMPACTION PRESSURE, PSI	350.0	350.0	350.0		
INITIAL MOISTURE,	2.6	2.6	2.6		
MOISTURE AT COMPACTION,	10.7	9.4	10.0		
DRY DENSITY, PCF	117.9	118.7	119.8		
EXUDATION PRESSURE, PSI	132.9	503.7	257.0		
G.E. (STABILITY), FT	.35	.28	.33		
G.E. (EXPANSION), FT	.00	.00	.00		

R-VALUE BY STABILITY : 67.4

Cal Test Method 301

B82604.01	Fitch Park
Twining Labs, Inc.	R-VALUE TEST
	Figure No. 49

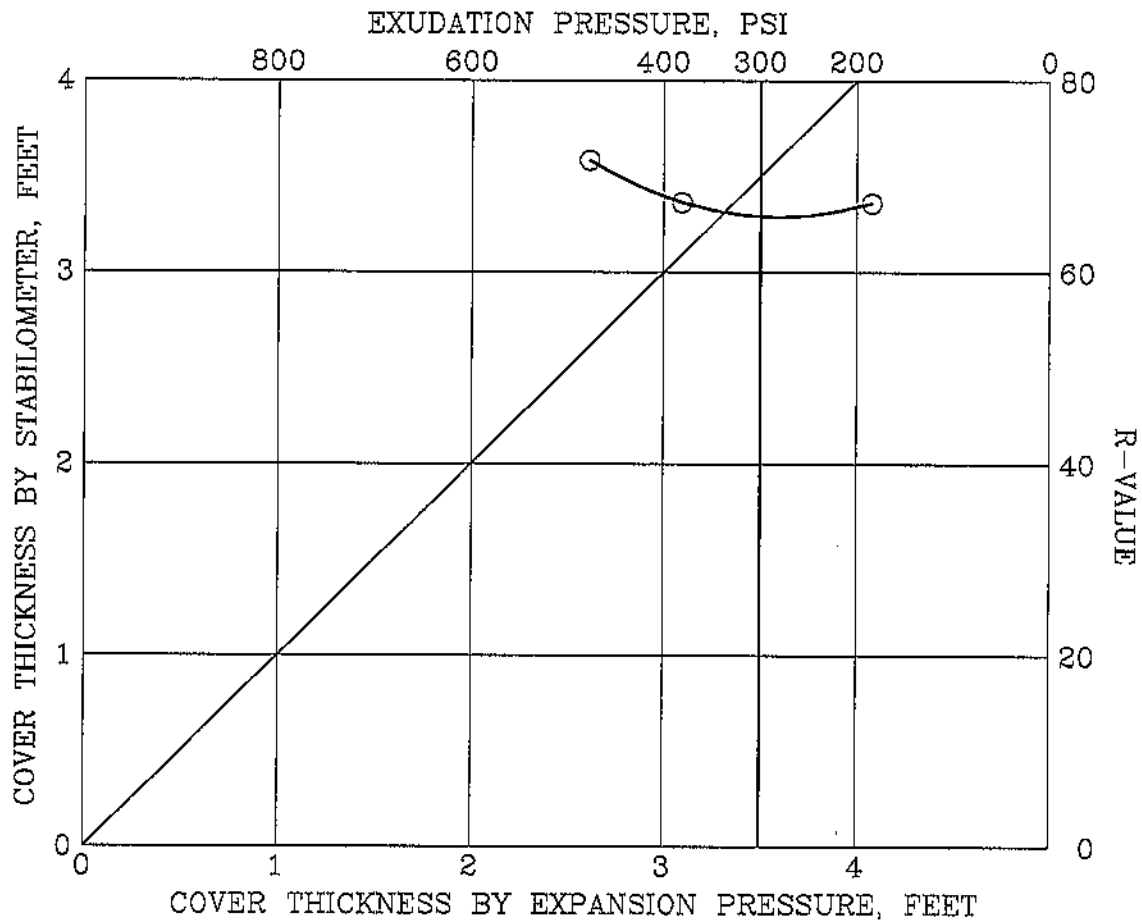

SAMPLE LOCATION : B-54,R-40
 SOIL DESCRIPTION : Silty SAND (SM)
 LIQUID LIMIT : SPECIFIC GRAVITY : 2.65
 PLASTIC LIMIT : DATE : 03/22/04

TEST NUMBER	1	2	3	4	5
COMPACTION PRESSURE, PSI	350.0	350.0	350.0		
INITIAL MOISTURE,	2.6	2.6	2.6		
MOISTURE AT COMPACTION,	11.1	12.0	11.6		
DRY DENSITY, PCF	113.0	113.1	113.9		
EXUDATION PRESSURE, PSI	477.5	184.6	381.2		
G.E. (STABILITY), FT	.30	.31	.31		
G.E. (EXPANSION), FT	.00	.00	.00		

R-VALUE BY STABILITY : 65.8

Cal Test Method 301

B82604.01

Fitch Park

Twining
 Labs, Inc.

R-VALUE TEST

Figure No. 50

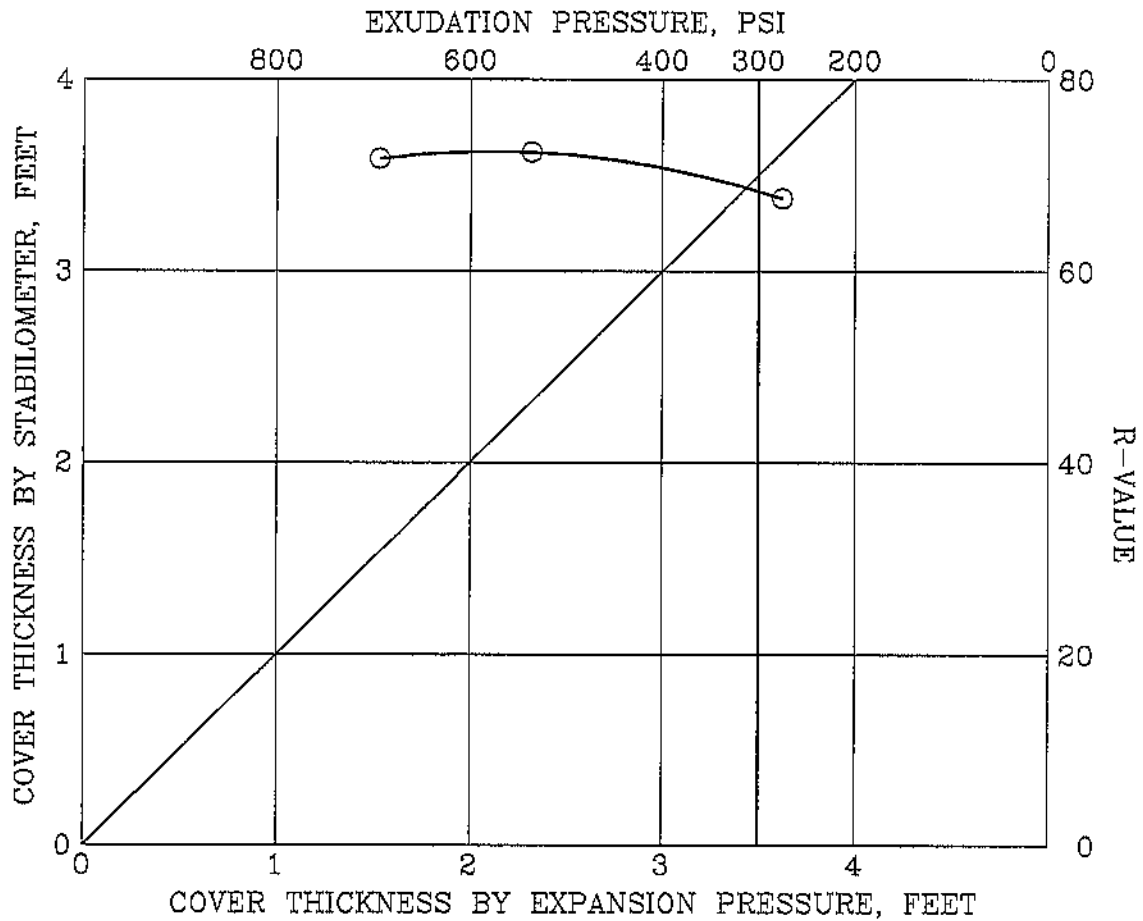

SAMPLE LOCATION : B-58,R-43,1-3.5'
 SOIL DESCRIPTION : Silty SAND (SM)
 LIQUID LIMIT : SPECIFIC GRAVITY : 2.65
 PLASTIC LIMIT : DATE : 03/26/04

TEST NUMBER	1	2	3	4	5
COMPACTION PRESSURE, PSI	350.0	350.0	350.0		
INITIAL MOISTURE,	1.5	1.5	1.5		
MOISTURE AT COMPACTION,	15.1	14.2	14.6		
DRY DENSITY, PCF	107.8	107.5	106.6		
EXUDATION PRESSURE, PSI	275.3	693.9	536.4		
G.E. (STABILITY), FT	.34	.29	.29		
G.E. (EXPANSION), FT	.00	.00	.00		

R-VALUE BY STABILITY : 68.3

Cal Test Method 301

B82604.01	Fitch Park
Twining Labs, Inc.	R-VALUE TEST Figure No. 53

ANALYTICAL CHEMISTRY DIVISION PROJECT COVER SHEET

REPORT DATE : March 24, 2004
LABORATORY ID : 4C17004.1-3

INVOICE # 4C17004
PROJECT MANAGER: A. HARKER
AMENDED REPORT: April 1, 2004

ATTENTION : Andrea Clarke
CLIENT : Clark Realty Capital, L.L.C.
PO Box 8540
Seaside, CA 93955

PROJECT INFO : FITCH PARK
PROJECT # : B82604.01

Please find enclosed the analytical results of your samples. In accordance with your instructions, the samples were analyzed for the components specified.

The Twining Laboratories is accredited by the State of California Department of Health Services for the analysis of Drinking Water, Wastewater and Hazardous Waste under Certificate No. 1371.

This report has been amended to reflect the correct project name and number.

Please feel free to contact us if you have any questions or comments regarding the analyses or results. Thank you for allowing us to serve your analytical needs.

ljt, ars

Figure No. 54

THE TWINING LABORATORIES, INC.

Ronald J. Boquist
Director of Analytical Chemistry

Rev. 4 08/03 jau (COVER)

CORPORATE
2527 Fresno Street
Fresno, CA 93721-1804
(559) 268-7021
Fax 268-0740

MODESTO
5253 Jerusalem Court, Suite E
Modesto, CA 95356-9322
(209) 342-2061
Fax 579-1480

VISALIA
130 North Kelsey Street, #H6
Visalia, CA 93291-9000
(559) 651-8280
Fax 651-8288

BAKERSFIELD
3651 Pegasus Drive, #117
Bakersfield, CA 93308-6843
(661) 393-6088
Fax 393-4643

MONTEREY
501 Ortiz Avenue
Sand City, CA 93955-3553
(831) 392-1056
Fax 268-7126

SACRAMENTO
5675 Power Inn Road, Suite C
Sacramento, CA 95824-2313
(916) 381-9477
Fax 381-9478

REPORT DATE : March 24, 2004
LABORATORY ID : 4C17004.1

THE TWINING LABORATORIES, INC.
PAGE 1 of 3

DATE SAMPLED : 03-12-04 by I. Bianchi
DATE RECEIVED : 03-17-04 at 1030 from I. Bianchi

CLIENT : GEOTECH / A. HARKER

PROJECT INFO : FITCH PARK
PROJECT# : B82604.01

ANALYZED BY : N. Tyler
REVIEWED BY : J. Ureno

DATE PREPARED : 03-19-04
DATE ANALYZED : 03-19-04

SAMPLE TYPE : Soil

CLIENT SAMPLE ID : R-1 / B-2 1-3.5

CORROSION	RESULT	UNITS	DLR	METHOD
pH	5.8	pH	N/A	ASTM D4972-89 Mod. ¹
Resistivity	1200	ohms/cm	N/A	CAL Test 424/ASTM D1125-82 ²
Chloride (Cl)	ND	% by weight	0.001	CAL Test 422/ASTM D4327-84 ²
Sulfate (SO ₄)	ND	% by weight	0.01	CAL Test 417/ASTM D4327-84 ²
Sulfate (SO ₄)*	21	mg/L	2.0	CAL Test 417/ASTM D4327-84

¹pH Determination performed on reagent-water leachate.

²Leachate preparation as per CAL Test reference; quantitative analysis as per ASTM reference.

% by weight: Percent by weight

ohms/cm: ohms per centimeter @ 25°C

N/A: Not Applicable

ASTM: American Society for Testing and Materials

ND: None Detected

mg/L: Milligrams per Liter (ppm)

CAL Test: Department of Transportation

DLR: Detection Limit for Reporting purposes

*extraction ratio of Solid: Water = 1:3

REPORT DATE : March 24, 2004
LABORATORY ID : 4C17004.2

THE TWINING LABORATORIES, INC.
PAGE 2 of 3

DATE SAMPLED : 03-12-04 by I. Bianchi
DATE RECEIVED : 03-17-04 at 1030 from I. Bianchi

CLIENT : GEOTECH / A. HARKER

PROJECT INFO : FITCH PARK
PROJECT# : B82604.01

ANALYZED BY : N. Tyler
REVIEWED BY : J. Ureno

DATE PREPARED : 03-19-04
DATE ANALYZED : 03-19-04

SAMPLE TYPE : Soil

CLIENT SAMPLE ID : R-12 / B-16 1-3.5

CORROSION	RESULT	UNITS	DLR	METHOD
pH	6.8	pH	N/A	ASTM D4972-89 Mod. ¹
Resistivity	7300	ohms/cm	N/A	CAL Test 424/ASTM D1125-82 ²
Chloride (Cl)	ND	% by weight	0.001	CAL Test 422/ASTM D4327-84 ²
Sulfate (SO ₄)	0.011	% by weight	0.01	CAL Test 417/ASTM D4327-84 ²
Sulfate (SO ₄)*	37	mg/L	2.0	CAL Test 417/ASTM D4327-84

¹pH Determination performed on reagent-water leachate.

²Leachate preparation as per CAL Test reference; quantitative analysis as per ASTM reference.

% by weight: Percent by weight

ohms/cm: ohms per centimeter @ 25°C

N/A: Not Applicable

ASTM: American Society for Testing and Materials

ND: None Detected

mg/L: Milligrams per Liter (ppm)

CAL Test: Department of Transportation

DLR: Detection Limit for Reporting purposes

*extraction ratio of Solid: Water = 1:3

REPORT DATE : March 24, 2004
LABORATORY ID : 4C17004.3

THE TWINING LABORATORIES, INC.
PAGE 2 of 3

DATE SAMPLED : 03-12-04 by I. Bianchi
DATE RECEIVED : 03-17-04 at 1030 from I. Bianchi

CLIENT : GEOTECH / A. HARKER

PROJECT INFO : FITCH PARK
PROJECT# : B82604.01

ANALYZED BY : N. Tyler
REVIEWED BY : J. Ureno

DATE PREPARED : 03-19-04
DATE ANALYZED : 03-19-04

SAMPLE TYPE : Soil

CLIENT SAMPLE ID : R-31 / B-42 1-3.5

CORROSION	RESULT	UNITS	DLR	METHOD
pH	6.1	pH	N/A	ASTM D4972-89 Mod. ¹
Resistivity	11000	ohms/cm	N/A	CAL Test 424/ASTM D1125-82 ²
Chloride (Cl)	ND	% by weight	0.001	CAL Test 422/ASTM D4327-84 ²
Sulfate (SO ₄)	ND	% by weight	0.01	CAL Test 417/ASTM D4327-84 ²
Sulfate (SO ₄)*	34	mg/L	2.0	CAL Test 417/ASTM D4327-84

¹pH Determination performed on reagent-water leachate.

²Leachate preparation as per CAL Test reference; quantitative analysis as per ASTM reference.

% by weight: Percent by weight

ohms/cm: ohms per centimeter @ 25°C

N/A: Not Applicable

ASTM: American Society for Testing and Materials

ND: None Detected

mg/L: Milligrams per Liter (ppm)

CAL Test: Department of Transportation

DLR: Detection Limit for Reporting purposes

*extraction ratio of Solid: Water = 1:3

APPENDIX D

ENGEO, INCORPORATED

Preliminary Trenching Evaluation Letter

DRAFT

Project No.
7496.1.001.01

October 23, 2006

Ms. Yousra Tilden
RMC Water and Environment
2290 N. First Street, Suite 212
San Jose, CA 95131

Subject: Marina Coast Recycled Water Pipeline – 100% Design
Marina, California

PRELIMINARY TRENCHING EVALUATION

Reference: LandMarine Geotechnics; Preliminary Geotechnical Investigation, Marina Coast Water District, Regional Urban Water Augmentation Project, 30% Design, Marina, California, July 2006, Project No. 107.001.

Dear Ms. Tilden:

This letter records the results of our preliminary consultation regarding trenching conditions along the Marina Coast Recycled Water Pipeline. Our consultation is based on our review of the referenced report for 30% design, interviews, and a site reconnaissance recently conducted for the project. ENGEO Incorporated is currently providing geotechnical services for final design in accordance with our proposal dated October 10, 2006.

TRENCHING CONDITIONS

Review of existing data suggests that the entire proposed alignment is underlain by Stabilized Dune Deposits consisting of clean to silty sands, which are loose to medium dense, in the upper 10 feet or so. The sands have varying moisture content, depending on the surfacing, local hydrology, and the time of year. The variables of fines content, density, and moisture content all effect trench stand-up time and, as a result, excavation shoring options.

Soil conditions along the chosen project alignment appear to be relatively uniform and not particularly favorable for trenching. Review of the available data indicates that there likely is not a pattern to the occurrence of silty soils which are more favorable to trench stand-up time. A good example of this is from the geotechnical investigation we reviewed for General Jim Moore Boulevard where borings drilled at 1,000-foot spacing revealed sands with fines content varying from 3 percent to 10 percent and moisture contents generally less than 5 percent. At the north end of the alignment an investigation for the Regional Wastewater management system yielded similar results. It is interesting to note that this latter investigation

included test pits. The pits encountered essentially the same material type. One pit caved, and one did not.

INTERVIEWS

Our staff has conducted several interviews with contractors, professionals, and local agency employees familiar with the area and has gathered a significant amount of information.

Don Chapin Company – Our engineer spoke with an employee of Don Chapin Company, a contractor based out of Salinas, California. Company projects include the Castroville Water Project, the Quail Meadows Project, the Gilroy Sports Park, Campo Pico Blanco and others. Several contacts have recommended them as knowledgeable about construction practices for pipelines along the Monterey Bay and Central Coast.

The staff member we talked to told us that the sands in the Marina and Seaside areas can be problematic for trenching because they tend to slough into the trench and undermine the adjacent pavement if cut too close to vertical. This person told us that they would personally rather use a trench shield than speed shoring; however, they acknowledged that where existing utilities conflicted with the proposed trench, a shored system such as plywood sheeting with speed shores would be necessary. The employee generally said that sands in the Marina area were able to stand open more easily than those in the Seaside or Sand City areas. This person did confirm that the soils are variable in the area and that differentiating reaches with good trenching conditions versus difficult trenching conditions could be challenging.

Sanco Incorporated - An employee with Sanco Incorporated, based in Campbell, California, communicated with our representative regarding potential trenching conditions that might be encountered in the Marina area. Company projects include a large commercial and retail center in the Marina area for Shea Homes, including a large underground stormwater drainage system, and similar projects throughout the central coast. Other contacts have recommended them as extremely knowledgeable about pipeline construction along the Monterey Coast. They claimed that speed shores were not an option they used for similar work in the Marina area. They said that they open cut the streets and then installed trench shields and pulled them along as they excavated at two recent projects in Marina.

Their staff member indicated that the sand would run at close to ¾:1 slope (horizontal:vertical) and that the material is similar to beach sand. The employee said that they did install some jacks with plywood to cross under utilities. They mentioned that a large amount of existing utilities would make it difficult to pull a trench shield, and that they thought it may be necessary to both remove and replace the utilities as you proceed or open the street wide enough to allow for the angle of repose.

Monterey Peninsula Engineering – Our engineer talked to an employee of Monterey Peninsula Engineering regarding potential trenching conditions in the area. MPE is currently constructing improvements on General Jim Moore Boulevard which will connect into the southern end of the proposed pipeline. The staff member we talked to claimed that vertical cuts up to eight feet deep could be accomplished if they were properly shored; however, deeper than eight feet, the trench would begin to slough in. The staff member claimed that in some areas you might get “12 feet if you were lucky” and in other areas much less. This person confirmed that conditions were variable throughout the area.

Monterey Bay Engineers – Our engineer talked to an employee of Monterey Bay Engineers, an engineering consulting company. Contacts at the City of Marina recommended them as knowledgeable about construction practices for pipelines in the project vicinity.

Their employee claimed that caving is generally not a construction issue if the excavation is less than six feet; however, this was assuming an open cut trench with sloped back sides. The employee indicated that “no one in the area counts on vertical trenches staying open”. Typically, this employee has seen slopes up to ½:1 stand open. Trenches deeper than six feet would need trench boxes for protection from caving.

Local Sanitary District – An inspector with the local sanitary district was able to speak with our representative regarding previous trenching experience in the area. The inspector was able to confirm that speed shoring was not feasible below approximately 5 feet in depth because of the tendency of the soils to cave. The inspector suggested that a good method to try and use would be the angled bucket recently used on Reservation Road to install pipeline to approximately 5 feet in depth. Review of pictures of this bucket show an angle of approximately 1:1 to ¾:1.

City of Marina – Members of the City of Marina staff confirmed the existence of variability in the tendency of the soils to stand open in relatively shallow vertical cut trenches throughout the area.

CSUMB – Staff members with the university spoke to our representative briefly about soil conditions along the proposed alignment. They confirmed that common methods used in the area for trenching include open cut with slopes of ¾:1 to 1:1.

Marina Coast Water District – Staff with the MCWD were able to talk with our representative regarding previous trenching experience in the area, some of which is directly applicable to the currently proposed alignment.

The water district recently installed a pipeline along Reservation Road between Imjin Avenue and Crescent Avenue. This section of pipeline was installed using open cut trenches to approximately 5 feet in depth, laid back at an angle of about ¾:1. The contractor had planned to use trench boxes but in general, did not have to use them for most of the installation. This trench

was excavated using an angled bucket, as shown in photographs received from the district. This particular method proved very successful and may be a method for consideration by contractors if the necessary trench section proves acceptable.

In addition, district employees related that past experience with contractors in the area had consisted of almost exclusive use of open cut trenches with slopes of $\frac{3}{4}$:1 to 1:1 (horizontal:vertical). These trenches were often shored with trench boxes to protect workers; however, sheet piling was very rarely used.

Field representatives of the Water District were also interviewed regarding trenching conditions. They related similar experience and gave specific information regarding Crescent Avenue and Reservation Road. The field staff interviewed said that conditions along our proposed alignment could vary considerably with some areas standing up at angles greater than 1:1, and others acting like “sugar sand”. Along Reservation Road, during installation of pipeline, much of the trench stood open at about $\frac{3}{4}$:1; however, there were also areas that were like “baby powder”. They also said that the hill on Crescent Avenue tended to be more dry towards the top (north of Reservation Road) and would stand open better the farther down towards Reservation Road you trenched.

The field staff interviewed also indicated that the intersection of Reservation and Crescent Avenue has a large number of underground utilities running through it. In general, for the Marina area, they said that utilities were sometimes removed and replaced if too close to an excavation.

Field staff confirmed that speed shoring would likely not be feasible for vertical cuts greater than about 5 feet deep.

Fort Ord Reuse Authority – Staff with FORA related their experience in the area regarding prior trenching work. In general, the staff said that you could expect stand up time of a few hours until the sand dries out. They also confirmed that speed shoring would be difficult to use below 5 feet deep, primarily because the sand would begin to run. The staff indicated that cribbing (similar to speed shoring) could be used if the sands were not running. FORA staff also said that they had seen trench boxes and speed shoring equipment at the nearby University Village Project (on the south side of 12th Avenue), but they had not seen them in use.

CONCLUSIONS AND DISCUSSION

At this time we can not differentiate different reaches of the project where flowing sand will or will not be encountered. Due to the nature of the sand deposition, there likely are local areas historically dominated by transient dunes where loose, dry, clean sand exists. There are also historic low areas where more silty sands may have accumulated. Also, areas likely exist where grading for the development of the streets and the military base has altered the natural

deposition. We will attempt to identify areas of varying conditions; however, realistically, conditions likely will vary over short distances and will be difficult to characterize.

It is our opinion that the project can be accomplished using sloped open cuts and an alternative trapezoidal trench backfill section. This may result in conflicts where adjacent utilities exist within the trench influence zone and will result in a larger area of street reconstruction than would vertical trenches. In some areas, particularly where shallow trenches are feasible, trenches may stand open vertically a sufficient time to allow for the use of internal shoring (plywood and speed shores/cribbing). While this configuration may save time and cost, it will likely be unacceptable where utilities are located within the influence zone of the trench.

In order to address these concerns we suggest the following:

- Identify areas where sloped open cuts will not interfere with adjacent utilities and allow sloped open cuts or internal shoring at the contractors own risk and discursion.
- In areas with close adjacent utilities, consider that the contractor may need to:
 - Use sheet piling with trench shields as cross bracing.
 - Relocate selected utilities and use sloped open cuts.
- Specify selected reaches of trenchless construction, as needed.

The Marina Coast Water District's standard specifications for recycled water pipelines prescribe minimum cover of 42 inches above the pipe (assuming a 12-inch pavement section). This implies a trench depth of 6 to 7 feet to the bottom of pipe bedding. Based on these dimensions and approximately 6 inches of clearance on either side of the pipe, we anticipate that an open cut trench with sides sloped at 1.5:1, as prescribed by OSHA for type C soils, can be constructed with a minimum saw cut of approximately 11 feet, side to side. In turn, existing utilities should have at least 1 foot of cover in the temporary cut, meaning that utilities with adequate vertical cover could be unaffected within 2 to 3 feet of the trench walls, and not have to be replaced. For planning purposes, we anticipate that an 8-foot zone clear of existing utilities centered along the pipeline will be sufficient to avoid significant removal and replacement activity due to disturbance by trenching activity. In areas where this is not feasible, sheet piling could be driven utilizing a trench shield as cross bracing. This may prove more cost effective than removal and replacement, and should be evaluated by the design team based on the anticipated areas and extent of utility conflicts.

We recommend that the project team proceed with the geotechnical investigation, including the further evaluation of trenching conditions, as planned. We will continue to consider this important issue in all the work we do on the project. We will work with you to provide appropriate design guidelines and information for the contractor to base their bids upon.

Please let us know if you have any questions or comments.

Very truly yours,

ENGEO INCORPORATED



Douglas Wahl
dw/le:trnch

Reviewed by:



R. William Rudolph

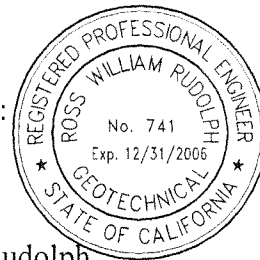

Attachment: Figure 5, Existing Geotechnical Information – Draft

- cc: 1 – Mr. Bob Hoffman – Carollo Engineers
1 – Mr. Brad Hamada – RMC Water and Environment (e-mail only)
1 – Mr. Lou Carella – Carollo Engineers (e-mail only)

DRAFT

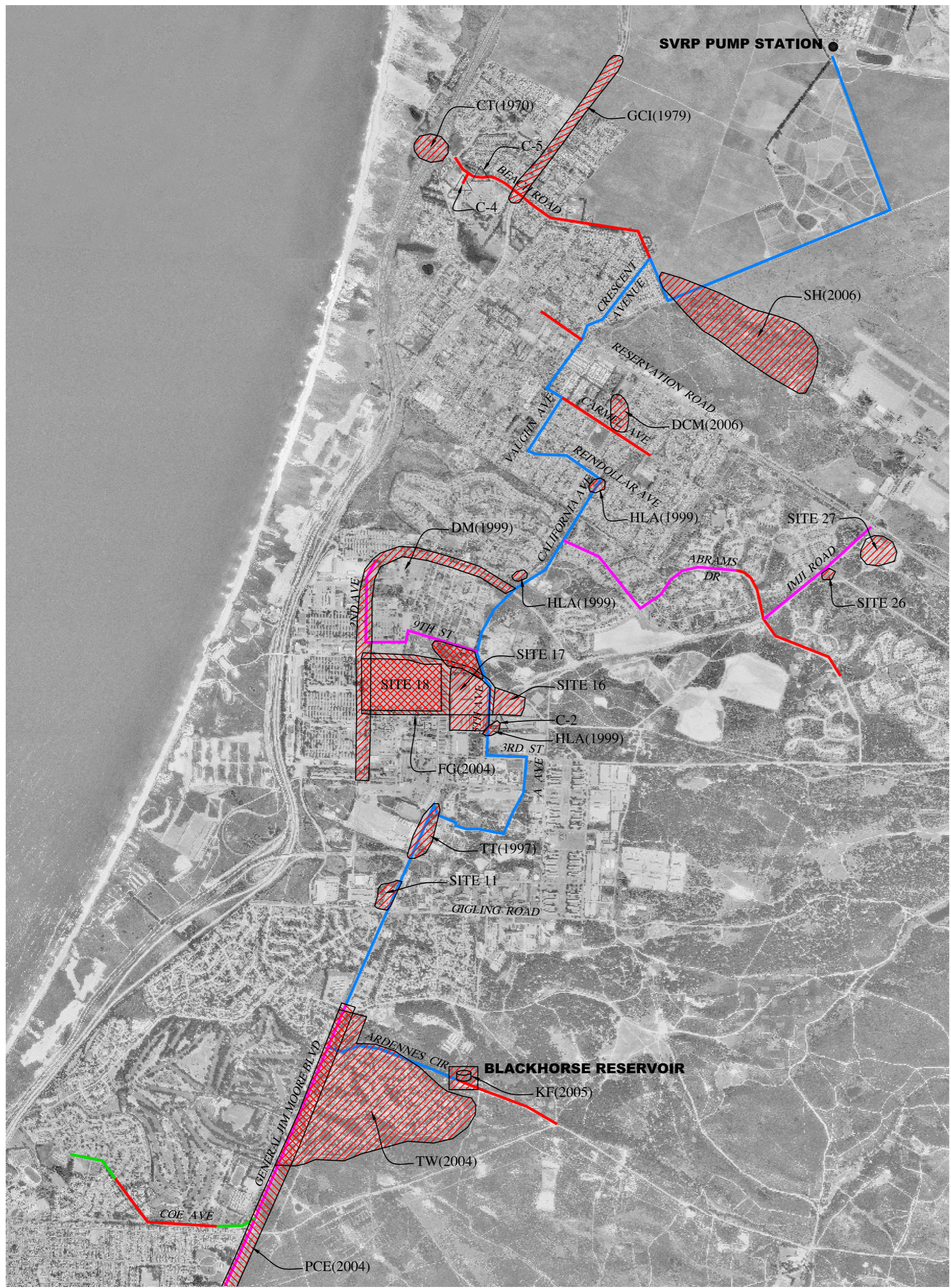

EXPLANATION

- DESIGNED BY OTHERS
- EXISTING RW PIPELINE
- TRANSMISSION MAIN (20"Ø)
- LATERALS (6"-8"Ø)
- △ C-5 CPT (LAND MARINE GEOTECHNICS, 2006)

GEOTECHNICAL EXPLORATION REFERENCES:

- CT 1970 - Reservation Road Undercrossing, soil logs obtained from Cal Trans District 5, 1970. (See Appendix F)
- GCI 1979 - Geotechnical Investigation, Phase II, Regional Wastewater Management System, Stage II, Monterey County, California, Prepared by Geotechnical Consultants Inc., April 1979. (See Appendix F)
- D & M 1999 - Report of Geotechnical Investigation, 12th Street Gateway/2nd Avenue Realignment, Former Fort Ord, Marina and Seaside, California, Prepared by D & M Consulting Engineers, Inc., November 1999. (See Appendix F)
- PCE 2004 - Geotechnical Investigation for General Jim Moore Boulevard and Eucalyptus Road, Seaside, California, Prepared by Pacific Crest Engineering Inc., February 2004. (See Appendix F)
- TW 2004 - Geotechnical Engineering Investigation Report, Proposed Fitch Park Military Housing, Fort Ord Military Reservation, Seaside, Monterey County, California, Prepared by Twining Laboratories, Inc., November 12, 2004. (See Appendix F)
- KF 2005 - Geotechnical Investigation Proposed East Garrison, "B" Zone Tanks, "D" Zone Reservoirs, "E" Zone Hydropneumatic Pump Station, and Transmission Mains, Marina Coast Water District, Marina, California, Prepared by Kleinfelder Inc., September 28, 2005. (See Appendix F)
- Site 11 - HLA. 1994. Harding Lawson Associates. Volume II - Remedial Investigation. Basewide Surface Water Outfall Investigation. Final. October 19, 1995. (See Appendix F)
- Site 16 - HLA. 1994. Harding Lawson Associates. Volume II - Remedial Investigation. Sites 16 and 17. Final. October 19, 1995. (See Appendix F)
- Site 17 - HLA. 1994. Harding Lawson Associates. Volume II - Remedial Investigation. Sites 16 and 17. Final. October 19, 1995. (See Appendix F)
- Site 18 - HLA. 1994. Harding Lawson Associates. Volume IV - Baseline Ecological Risk Assessment. Final. October 19, 1995. (See Appendix F)
- Site 25 - HLA. 1994. Harding Lawson Associates. Volume IV - Baseline Ecological Risk Assessment. Final. October 19, 1995. (See Appendix F)
- Site 26 - HLA. 1994. Harding Lawson Associates. Volume IV - Baseline Ecological Risk Assessment. Final. October 19, 1995. (See Appendix F)
- Site 27 - HLA. 1994. Harding Lawson Associates. Volume IV - Baseline Ecological Risk Assessment. Final. October 19, 1995. (See Appendix F)
- HLA 1999 - Test Pit Logs Obtained From Fort Ord Reuse Authority, Logged by Harding Lawson Associates, November 1999, Location Maps Included. (See Appendix F)
- TT 1997 - Boring Logs Obtained From Fort Ord Reuse Authority, Logged by TerraTech Inc., February 1997, No Location Map Included. (See Appendix F)
- SH 2006 - Draft Well Installation Completion Report, Armstrong Ranch, Operable Unit 1, Former Fort Ord, California, Total Environmental Restoration Contract, Contract No. DACW05-96-D-0011, Prepared by Shaw Environmental Group Inc., September 2006. (See Appendix F)
- DCM 2006 - Geotechnical Engineering Investigation Report, Marina Coast Water District, 2005 Marina Sewer Improvement Projects, Marina, California, Prepared by DCM Engineering, August 2006. (See Appendix F)
- FG 2004 - Geotechnical Study, California State University Monterey Bay, North Campus Housing, Monterey County, California, Prepared by Fugro West Inc., March 2004. (See Appendix F)

BASE MAP SOURCE: USGS, TERRASERVER, 1989



EXISTING GEOTECHNICAL INFORMATION
MARINA COAST RECYCLING WATER PIPELINE
MARINA, CALIFORNIA

PROJECT NO.: 7496.1.001.01
DATE: OCTOBER 2006
DRAWN BY: PC
CHECKED BY:

FIGURE NO.
5

DRAFT